

NCN8025AEVB

Evaluation Board Manual for NCN8025A QFN-24



Prepared By: Philippe Andre

ON Semiconductor®

<http://onsemi.com>

EVALUATION BOARD MANUAL

INTRODUCTION

This document gives a detailed description of the NCN8025A Evaluation Board (QFN-24 version) with the Bill Of Material (BOM), board schematic and layout. The appropriate lab test setups are also provided. The NCN8025A Evaluation Board has been designed to help for a quick evaluation of the NCN8025A Compact and Cost-Effective Smart Card Interface device.

This document has to be used with the NCN8025A datasheet. The datasheet contains full technical details regarding the NCN8025A specifications and operation. The board (FR4 material) is implemented in two metal layers. The top and bottom layers have thicknesses of 35 µm. The PCB thickness is 1.6 mm with dimensions of 89 mm by 68 mm (see Figure 1).

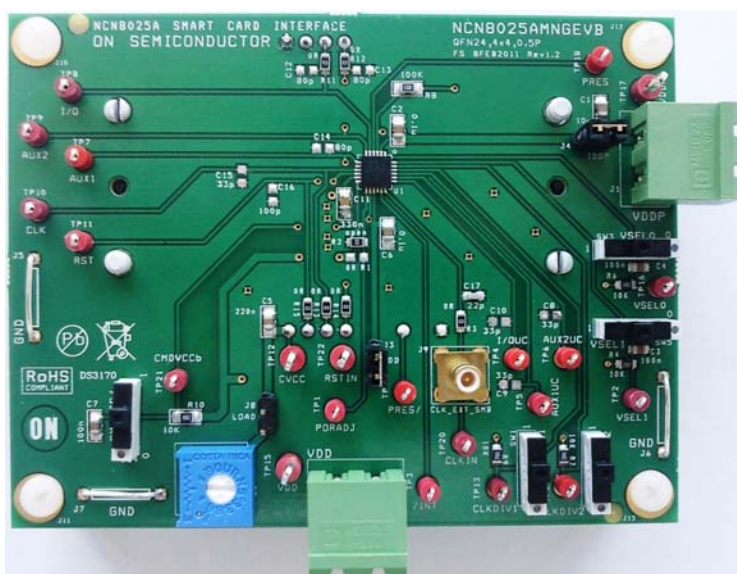

Figure 1. Demo Board

EQUIPMENT

Description	Main Features	Example of Equipment (Note 1)	Qty.
Regulated Power Supply	200 mA DC current capability	Tektronix PS2520G	2
Multimeter		Keitley 2000 or 2001	2
Sourcemeeter		Keitley 2400	1
Oscilloscope	500 MHz Bandwidth, four channel scope, min 1 Mbit memory per channel (Note 2)	Tektronix TDS744, 754 or 784 / TDS5054 series or Lecroy WR5060 TDS5104B, 1 GHz, 5GS/s	1
Voltage probe	4 probes 500 MHz Bandwidth	Tektronix or Lecroy	4
Waveform generator	Pattern generator	Agilent 81104A 80 MHz or HP8110A 150 MHz 2 outputs	1
SMB Cable		External Clock Input	1

1. Equipment used in the context of this Application Note Manual.
2. Greater Scope memory per channel offers better resolution.

TEST PROCEDURE

See Figure 2.

Initial Setups

The initial setups given here are recommended before starting measurements on the board.

- Set the CMDVCC/ in the OFF position (High).
- Set CLKDIV1 and CLKDIV2 into low position (lowest frequency Fclk)
- 2 pins are used to change the Card V_{CC} power supply or the smart card interface mode which can be 1.8 V, 3.0 V or 5.0 V. These 2 pins are VSEL0 and VSEL1 and on the board, changing VSEL0 and VSEL1 is done using 2 corresponding switches (see Figure 2) according to the below Table 1. When VSEL0 = 0 then VSEL1 is in the mode 5 V/3 V_{bar}, when VSEL0=1 then VSEL1 is in the mode 1.8 V / 3 V_{bar}. The initial setup can be VSEL0 = 0 and VSEL1 = 1 for selecting the 5 V mode. The card V_{CC} (CVCC) output voltage cannot be changed on the fly when the smart card interface is active (/CMDVCC = Low). For changing card V_{CC} it is necessary to deactivate the device then to reconfigure the card V_{CC} by setting the appropriate VSEL0 and VSEL1 finally the smart can be activated again with this new smart card power supply voltage.

Table 1. CVCC Programming

VSEL0	VSEL1	CVCC
0	0	3.0 V
0	1	5.0 V
1	0	3.0 V
1	1	1.8 V

- As a precaution, turn the 1 kΩ potentiometer to obtain a resistor output value of 1 kΩ, and then connect the jumper.

DC Power Supplies

Two power supplies are used to bias the demo board. VDDP is the input voltage of LDO Regulator. VDD is the

“digital” power supply which biases the input stages of the NCN8025A device (control and signal inputs).

VDD and VDDP must be connected to the board to ensure correct operation. Connect the VDD and VDDP power supplies using the 2 pin male connectors J2 and J1 respectively.

Clock Frequency

CLKDIV1 and CLKDIV2 select the frequency divider according to the table given below.

Table 2. Clock Division Ratio Programming

CLKDIV1	CLKDIV2	Divider
1	0	DIV 1/1
1	1	DIV 1/2
0	1	DIV 1/4
0	0	DIV 1/8

Card Presence

The socket we use is a normally open, so PRES/ has been chosen; nevertheless the PRES and PRES/ test points can also be used for signaling the presence of a card and starting up the circuit.

The Clock

The clock is applied externally (SMB connector).

Start the Measurement

To start the measurements, set the board as it follows:

- Set CLKDIV1 and CLKDIV2 to select the correct frequency.
- Set 5 V / 3 V_{bar} to select the correct output voltage.
- Jumpers:
 - 1 kΩ potentiometer jumper: not connected to start the measure.
- Finally, toggle /CMDVCC from High to Low to start the device (activation sequence run).

NCN8025AEVB

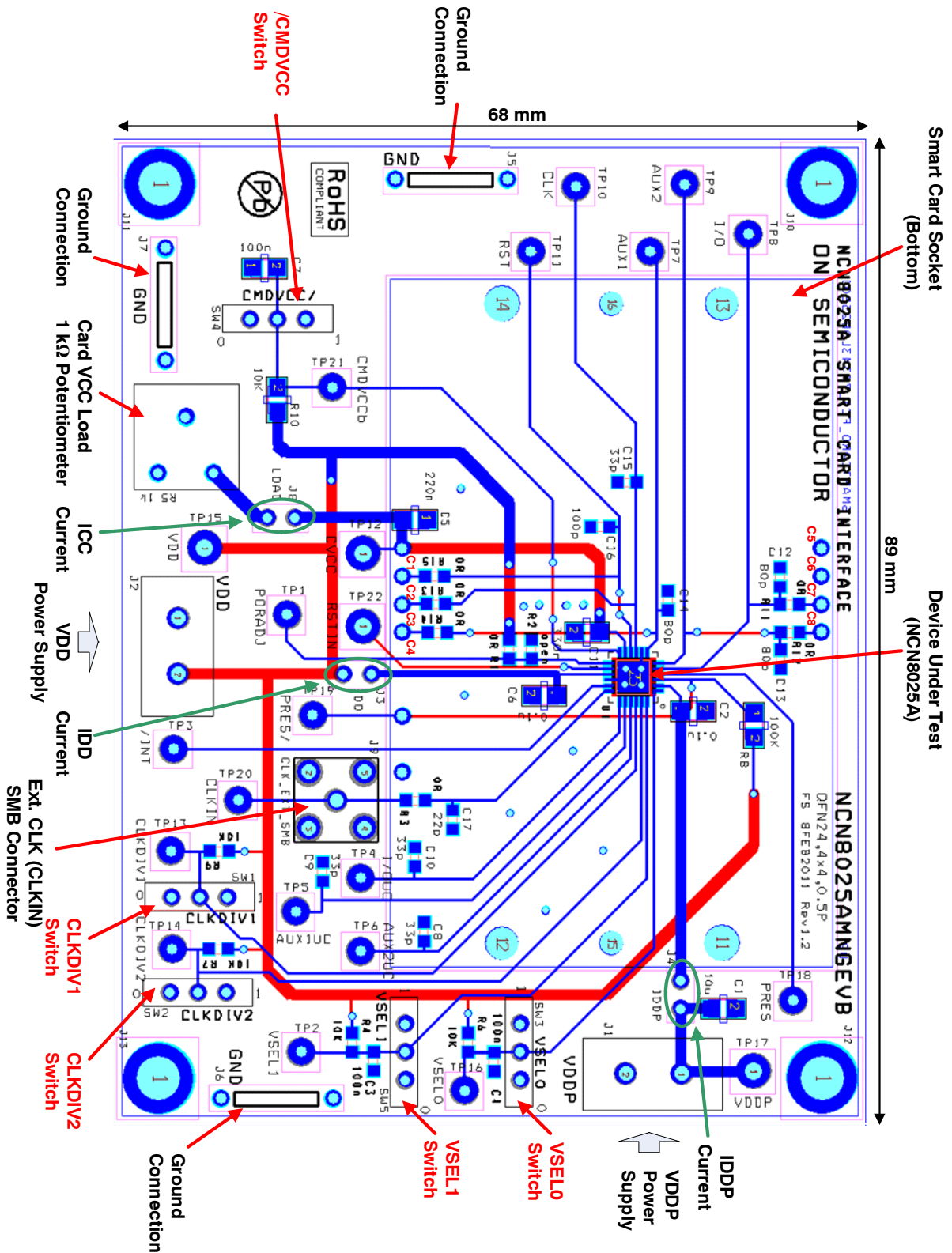

Figure 2. Board Description

NCN8025AEVB

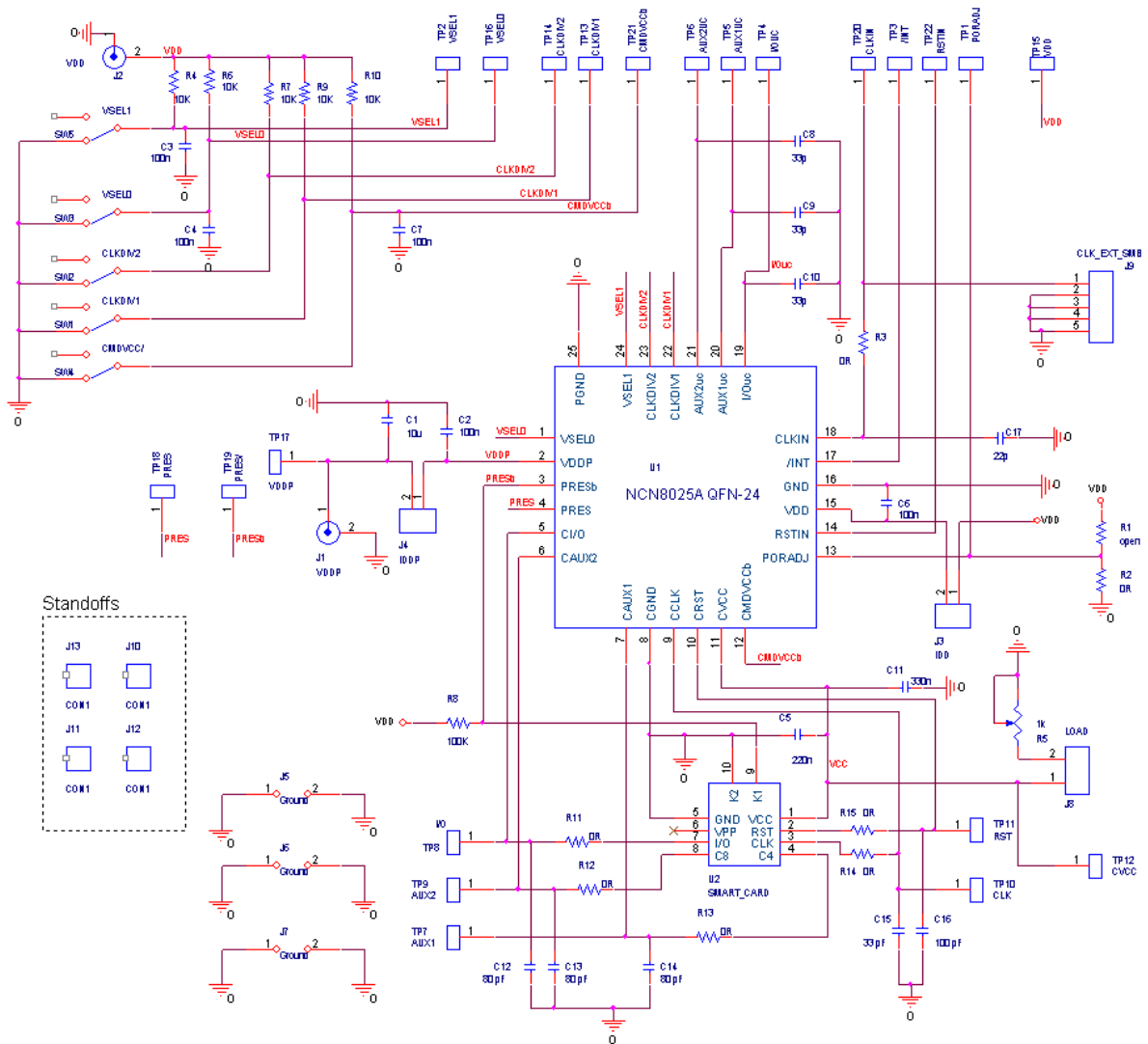

Figure 3. Board Schematic

NCN8025AEVB

Bill of Material

Designator	Qty	Description	Value	Tol	Footprint	Manufacturer	Manufacturer Part #	Lead Free
C1	1	CAP CER 10UF 6.3V 20% X5R 0805	10uF	20%	0805	Murata	GRM21BR60J106ME19L	Yes
C2, C6, C7	3	CAP CER .1UF 25V 10% X7R 0805	100nF	10%	0805	Murata	GRM21BR71E104KA01L	Yes
C3, C4	2	CAP CER .1UF 25V 10% X7R 0603	100nF	10%	0603	Murata	GRM188R71E104KA01D	Yes
C5	1	CAP CER .22UF 16V X7R 10% 0805	220nF	10%	0805	TDK Corporation	C2012X7R1C224K	Yes
C8, C9, C10, C15	4	CAP CER 33PF 16V X7R 0603	33pF	5%	0603	AVX Corporation	Do not populate	Yes
C11	1	CAP CER .33UF 16V X7R 10% 0805	330nF	10%	0805	TDK Corporation	C2012X7R1C334K/1.25	Yes
C12, C13, C14	3	Do not populate	80pF	-	0603	Do not populate	Do not populate	-
C16	1	Do not populate	100pF	-	0603	Do not populate	Do not populate	-
C17	1	CAP CERAMIC 22PF 50V NPO 0603	22pF	5%	0603	Yageo	CC0603JRNP09BN220	Yes
R1	1	Do not populate	Open	-	0805	Do not populate	Do not populate	-
R2, R3, R11, R12, R13, R14, R15	7	RES 0.0 OHM 1/8W 0603 SMD	0R	-	0603	Stackpole Electronics Inc	RMCF0805ZT0R00	Yes
R4, R6, R7, R9, R10	5	CMS resistor 1%, 1/4W	10k	1%	0603	Philips Components	232272461003	Yes
R5	1	Single turn Cermet trimmer, 1k, 0.5W, 10%	1k	-	CERMET-72P T	Bourns	3386F-102LF-ND	Yes
R8	1	CMS resistor 1%, 1/4W	100k	1%	0805	Philips Components	232272461004	Yes
SW1 to SW5	5	PCB slide switches	-	-	INTER3-2,54	EAO	09.03290.01	Yes
TP1 to TP11, TP13, TP14, TP16, TP18 to TP21	18	Clip Test Point, Hole Diameter 1.0mm (0.040 mil)	-	-	TP_1.0MMHO LE_KEYSTON E_5000	Keystone	5000	Yes
TP12, TP15, TP17, TP22	4	Clip Test Point, Hole Diameter 1.6mm (0.063 mil)	-	-	TP_1.6MMHO LE_KEYSTON E_5010	Keystone	5010	Yes
J1,J2	2	VDD, VDDP, 2-Pins Male Connector, 5.08mm Step	-	-	MSTBA2	Phoenix Contact	MSTBA2.52G5.08	Yes

NCN8025AEVB

Bill of Material

Designator	Qty	Description	Value	Tol	Footprint	Manufacturer	Manufacturer Part #	Lead Free
J3, J4, J8	3	IDD, IDDP, LOAD, Breakable Single Row Header (2 Pins)	-	-	CON2-2.54	TYCO Amp	5-826629-0	Yes
J5, J6, J7	3	Ground Strap, Brass, Diameter 1.0mm, Pitch 10.16mm, Height 9.9mm	-	-	GND_STRP	HARWIN	D3082-46	Yes
J9	1	SMB connector	-	-	SMB/V	IMS	111510001	Yes
U1	1	NCN8025A Smart Card Interface	-	-	QFN 24 4X4 ENGINEERING	ON Semiconductor	NCN8025AMNTXG	Yes
U2	1	Smart card socket	-	-	SMARTCARD_FCI_74343L_0825S01	FCI	7434L0825S01LF	Yes
none	4	Standoff nut	-	-	STANDOFF HOLE	Keystone Electronics	1903C	Yes
none	4	Standoff screw	-	-	STANDOFF HOLE	Keystone Electronics	4814K-ND	Yes

ON Semiconductor and **ON** are registered trademarks of Semiconductor Components Industries, LLC (SCILLC). SCILLC reserves the right to make changes without further notice to any products herein. SCILLC makes no warranty, representation or guarantee regarding the suitability of its products for any particular purpose, nor does SCILLC assume any liability arising out of the application or use of any product or circuit, and specifically disclaims any and all liability, including without limitation special, consequential or incidental damages. "Typical" parameters which may be provided in SCILLC data sheets and/or specifications can and do vary in different applications and actual performance may vary over time. All operating parameters, including "Typicals" must be validated for each customer application by customer's technical experts. SCILLC does not convey any license under its patent rights nor the rights of others. SCILLC products are not designed, intended, or authorized for use as components in systems intended for surgical implant into the body, or other applications intended to support or sustain life, or for any other application in which the failure of the SCILLC product could create a situation where personal injury or death may occur. Should Buyer purchase or use SCILLC products for any such unintended or unauthorized application, Buyer shall indemnify and hold SCILLC and its officers, employees, subsidiaries, affiliates, and distributors harmless against all claims, costs, damages, and expenses, and reasonable attorney fees arising out of, directly or indirectly, any claim of personal injury or death associated with such unintended or unauthorized use, even if such claim alleges that SCILLC was negligent regarding the design or manufacture of the part. SCILLC is an Equal Opportunity/Affirmative Action Employer. This literature is subject to all applicable copyright laws and is not for resale in any manner.

PUBLICATION ORDERING INFORMATION

LITERATURE FULFILLMENT:

Literature Distribution Center for ON Semiconductor
P.O. Box 5163, Denver, Colorado 80217 USA
Phone: 303-675-2175 or 800-344-3860 Toll Free USA/Canada
Fax: 303-675-2176 or 800-344-3867 Toll Free USA/Canada
Email: orderlit@onsemi.com

N. American Technical Support: 800-282-9855 Toll Free USA/Canada
Europe, Middle East and Africa Technical Support:
Phone: 421 33 790 2910
Japan Customer Focus Center
Phone: 81-3-5773-3850

ON Semiconductor Website: www.onsemi.com

Order Literature: <http://www.onsemi.com/orderlit>

For additional information, please contact your local Sales Representative

NCN8025AEVB/D