

Features

- ✧ Low power loss, High efficiency
- ✧ High current capability, Low VF
- ✧ High reliability
- ✧ High surge current capability
- ✧ Epitaxial construction
- ✧ Guard-ring for transient protection
- ✧ For use in low voltage, high frequency inverter, free wheeling, and polarity protection application
- ✧ Green compound with suffix "G" on packing code & prefix "G" on datecode

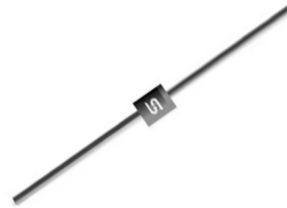

Mechanical Data

- ✧ Cases: DO-15 molded plastic
- ✧ Epoxy: UL 94V-0 rate flame retardant
- ✧ Lead: Pure tin plated, lead free, solderable per MIL-STD-202, Method 208 guaranteed
- ✧ High temperature soldering guaranteed: 260°C/10s / .375", (9.5mm) lead lengths at 5 lbs, (2.3kg) tension
- ✧ Weight: 0.4 grams

Ordering Information (example)

Part No.	Package	Packing	INNER TAPE	Packing code	Packing code (Green)
SR202	DO-15	1.5K / AMMO box	52mm	A0	A0G

Maximum Ratings and Electrical Characteristics

Rating at 25 °C ambient temperature unless otherwise specified.

Single phase, half wave, 60 Hz, resistive or inductive load.

For capacitive load, derate current by 20%

Type Number	Symbol	SR 202	SR 203	SR 204	SR 205	SR 206	SR 209	SR 210	SR 215	Units
Maximum Recurrent Peak Reverse Voltage	V_{RRM}	20	30	40	50	60	90	100	150	V
Maximum RMS Voltage	V_{RMS}	14	21	28	35	42	63	70	105	V
Maximum DC Blocking Voltage	V_{DC}	20	30	40	50	60	90	100	150	V
Maximum Average Forward Rectified Current	$I_{F(AV)}$	2								A
Peak Forward Surge Current, 8.3 ms Single Half Sine-wave Superimposed on Rated Load (JEDEC method)	I_{FSM}	50								A
Maximum Instantaneous Forward Voltage (Note 1) @ 2 A	V_F	0.55		0.70		0.85		0.95		V
Maximum DC Reverse Current at Rated DC Blocking Voltage @ $T_A=25^\circ C$ @ $T_A=100^\circ C$ @ $T_A=125^\circ C$	I_R	0.5				0.1				mA
		10		5.0		-				
		-				2				
Typical Junction Capacitance (Note 2)	C_j	120		85		65				pF
Typical Thermal Resistance	$R_{\theta JA}$	75								$^\circ C/W$
	$R_{\theta JC}$	14								
	$R_{\theta JL}$	21.7								
Operating Junction Temperature Range	T_J	- 65 to + 150								$^\circ C$
Storage Temperature Range	T_{STG}	- 65 to + 150								$^\circ C$

Note1: Pulse Test with PW=300u sec, 1% Duty cycle

Note2: Measured at 1 MHz and Applied Reverse Voltage of 4.0V D.C.

Version:F12

RATINGS AND CHARACTERISTIC CURVES (SR202 THRU SR215)

FIG. 1- FORWARD CURRENT DERATING CURVE

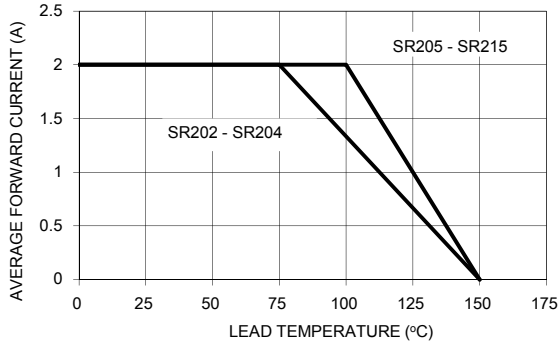

FIG. 2- MAXIMUM NON-REPETITIVE FORWARD SURGE CURRENT

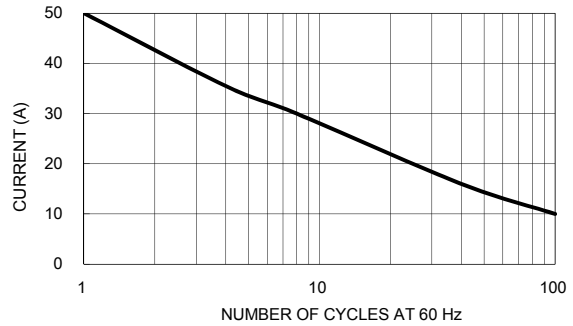

FIG. 3- TYPICAL FORWARD CHARACTERISTICS

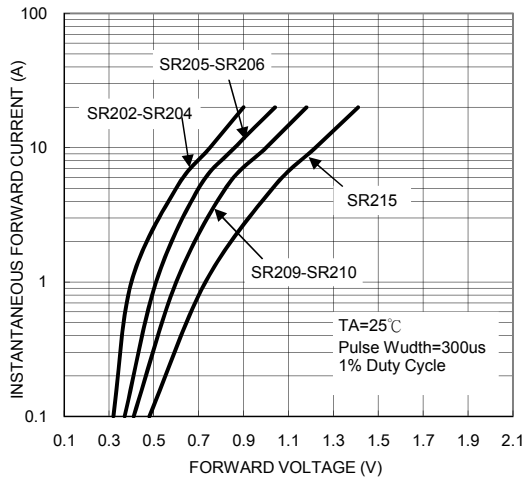

FIG. 4- TYPICAL REVERSE CHARACTERISTICS

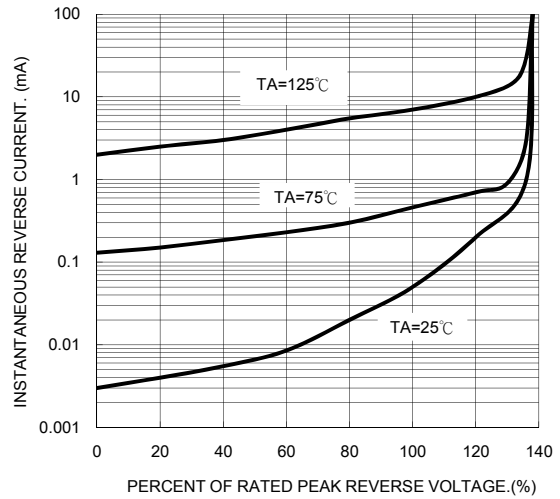

FIG. 5- TYPICAL JUNCTION CAPACITANCE

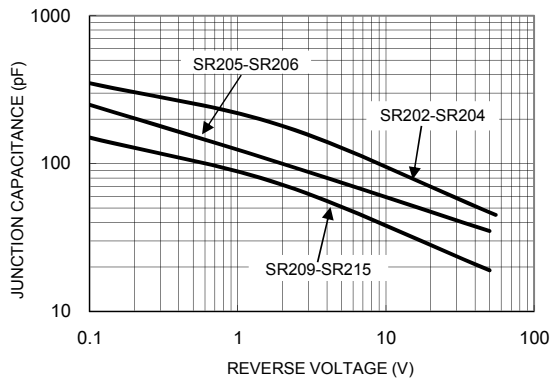
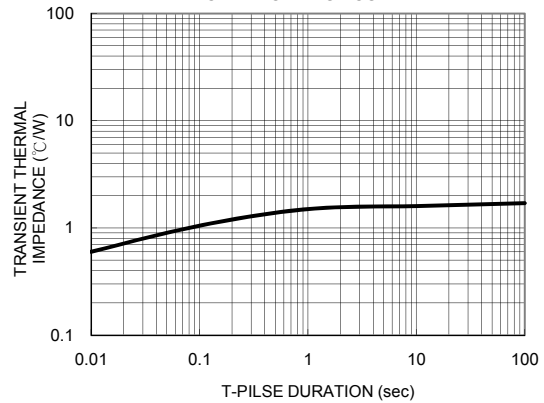

FIG. 6- TYPICAL TRANSIENT THERMAL CHARACTERISTICS



Version:F12

Ordering information

Part No.	Package	Packing	INNER TAPE	Packing code	Packing code (Green)
SR2xx (Note)	DO-15	1.5K / AMMO box	52mm	A0	A0G
	DO-15	3.5K / 13" Reel	52mm	R0	R0G
	DO-15	1K / Bulk packing		B0	B0G

Note: "xx" is Device Code from "02" thru "15".

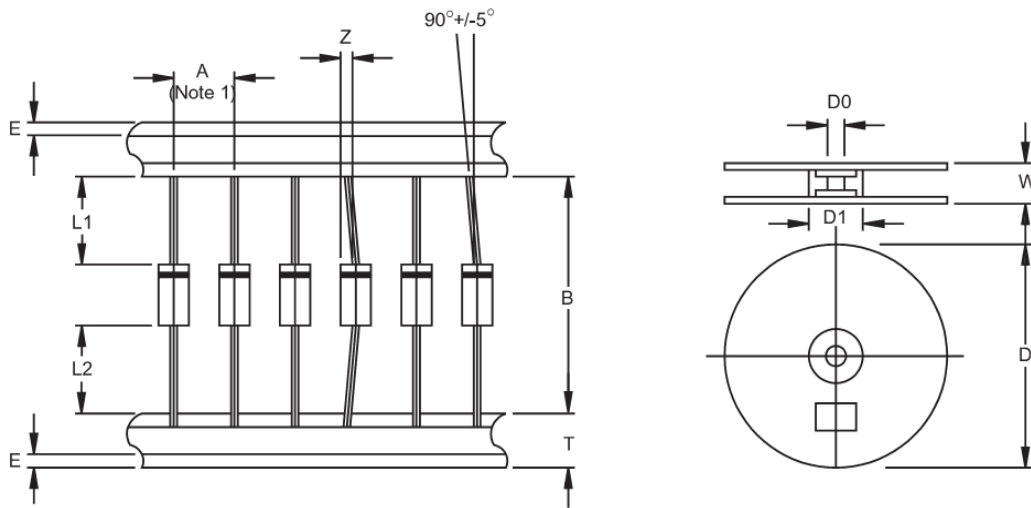
AXIAL LEAD TAPING SPECIFICATIONS

Outline	A	B	Z	T	E	L1-L2	D	D1	D0	W
	DO-15	±0.5	±1.5	MAX	±0.4	MAX	MAX	330	±0.3	±0.4

Unit (mm)

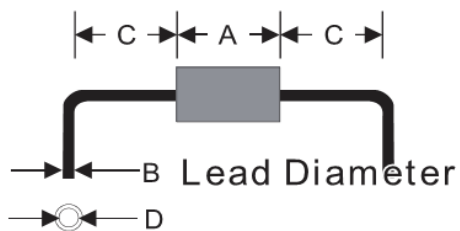
Suggested Mounting Hole Rule

Symbol	Unit(mm)
A	6.4
B	0.8
C	3.0
D	1.2

Dimensions

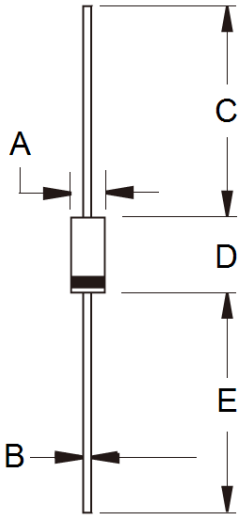

DIM.	Unit(mm)		Unit(inch)	
	Min	Max	Min	Max
A	2.60	3.60	0.102	0.142
B	0.70	0.90	0.028	0.035
C	25.40	-	1.000	-
D	5.80	7.60	0.228	0.299
E	25.40	-	1.000	-

Marking Diagram

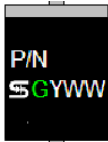

- P/N = Specific Device Code
- G = Green Compound
- YWW = Date Code