



MIC23150 Evaluation Board

4MHz 2A Buck Regulator with HyperLight Load™

General Description

The MIC23150 is a 2A 4MHz switching regulator featuring HyperLight Load™ mode. The MIC23150 is highly efficient throughout the entire output current range, drawing just 23µA of quiescent current in operation. The tiny 2mm x 2mm MLF® package, in combination with the 4MHz switching frequency, enables a compact sub-1mm height solution with only three external components. The MIC23150 provides accurate output voltage regulation under the most demanding conditions and responds extremely quickly to a load transient with exceptionally small output voltage ripple.

Factoring in the output current, the internal circuitry of the MIC23150 automatically selects between two modes of operation for optimum efficiency. Under light load conditions, the MIC23150 goes into HyperLight Load™ mode. HyperLight Load™ uses a Pulse-Frequency Modulation (PFM) control scheme that controls the off time at light load. This proprietary architecture reduces the amount of switching needed at light load, thereby increasing operating efficiency. The MIC23150 attains up to 87% efficiency at 1mA output load. As the load current increases beyond approximately 100mA, the device operates using the Pulse-Width Modulation (PWM) method for up to 93% efficiency at higher load. The two modes of operation ensure the highest efficiency across the entire load range.

The MIC23150 operates from an input voltage range of 2.7V to 5.5V and features internal power MOSFETs that deliver up to 2A of output current. This step-down regulator provides an output voltage accuracy of +/-2.5% across the junction temperature range of -40°C to +125°C. The MIC23150 is available in fixed output versions supporting an output voltage as low as 1.0V.

Requirements

The MIC23150 evaluation board requires an input power source that is able to deliver greater than 2A at 2.7V to the MIC23150. The output load can either be an active (electronic) or passive (resistive) load.

Getting Started

1. **Connect an external supply to the V_{IN} (J1) terminal.** Apply the desired input voltage to V_{IN} (J1) and ground (J2) terminals of the evaluation board, paying careful attention to polarity and supply voltage ($2.7V \leq V_{IN} \leq 5.5V$). An ammeter may be placed between the input supply and the V_{IN} (J1) terminal. Be sure to monitor the supply voltage at the V_{IN} (J1) terminal, since the ammeter and/or power lead resistance can reduce the voltage supplied to the device.
2. **Connect a load to the V_{OUT} (J3) and ground terminal (J4).** The load can be either passive (resistive) or active (electronic load). An ammeter may be placed between the load and the output terminal. Ensure the output voltage is monitored at the V_{OUT} (J3) terminal.
3. **Enable the MIC23150.** The MIC23150 evaluation board has a pull-up resistor to V_{IN}. To disable the device, apply a voltage below 0.5V to the EN (J5) terminal. In the absence of the pull-up resistor, the device is enabled by applying a voltage greater than 1.2V to the EN (J5) terminal. The enable pin must be either pulled high or low for proper operation. Removing the pull-up resistor and leaving the pin floating will cause the regulator to operate in an unknown state.

Output Voltage

The MIC23150 evaluation board is available with the following output voltage options listed below:

Ordering Information

Part Number	Description ⁽²⁾
MIC23150-CYMT EV ⁽¹⁾	1.0V Fixed Output Evaluation Board
MIC23150-4YMT EV ⁽¹⁾	1.2V Fixed Output Evaluation Board
MIC23150-GYMT EV	1.8V Fixed Output Evaluation Board
MIC23150-SYMT EV	3.3V Fixed Output Evaluation Board

Note:

1. Contact Micrel Marketing
2. Other voltage options available on request. Contact Micrel.

HyperLight Load is a trademark of Micrel, Inc. MLF is a registered trademark of Amkor Technology.

Micrel Inc. • 2180 Fortune Drive • San Jose, CA 95131 • USA • tel +1 (408) 944-0800 • fax + 1 (408) 474-1000 • <http://www.micrel.com>

HyperLight Load™ Mode

MIC23150 uses a minimum on and off time proprietary control loop (patented by Micrel). When the output voltage falls below the regulation threshold, the error comparator begins a switching cycle that turns the PMOS on and keeps it on for the duration of the minimum-on-time. This increases the output voltage. If the output voltage is over the regulation threshold, then the error comparator turns the PMOS off for a minimum-off-time until the output drops below the threshold. The NMOS acts as an ideal rectifier that conducts when the PMOS is off. Using a NMOS switch instead of a diode allows for lower voltage drop across the switching device when it is on. The asynchronous switching combination between the PMOS and the NMOS allows the control loop to work in discontinuous mode for light load operations. In discontinuous mode, the MIC23150 works in pulse frequency modulation (PFM) to regulate the output. As the output current increases, the off-time decreases, thus provides more energy to the output. This switching scheme improves the efficiency of MIC23150 during light load currents by only switching when it is needed. As the load current increases, the MIC23150 goes into continuous conduction mode (CCM) and switches at a frequency centered at 4MHz. The equation to calculate the load when the MIC23150 goes into continuous conduction mode may be approximated by the following formula:

$$I_{LOAD} > \left(\frac{(V_{IN} - V_{OUT}) \times D}{2L \times f} \right)$$

As shown in the previous equation, the load at which MIC23150 transitions from HyperLight Load™ mode to PWM mode is a function of the input voltage (V_{IN}), output voltage (V_{OUT}), duty cycle (D), inductance (L) and frequency (f). As shown in Figure 1, as the Output Current increases, the switching frequency also increases until the MIC23150 goes from HyperLight Load™ mode to PWM mode at approximately 120mA. The MIC23150 will switch at a relatively constant frequency around 4MHz once the output current is over 120mA.

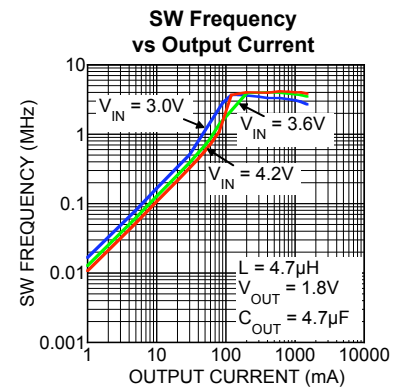
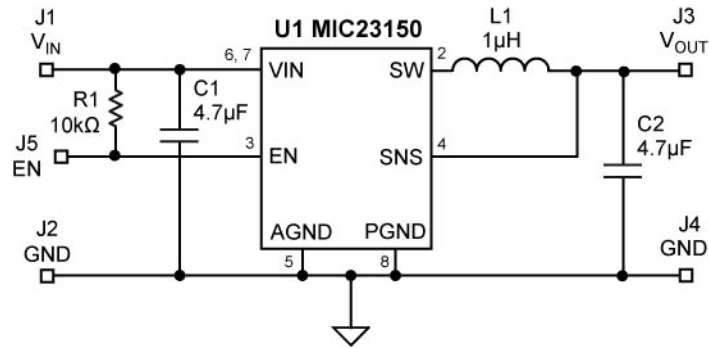

Figure 1. SW Frequency vs. Output Current

MIC23150 Typical Application Circuit



Bill of Materials

Item	Part Number	Manufacturer	Description	Qty.
C1, C2	C1608X5R0J475K	TDK ⁽¹⁾	4.7μF Ceramic Capacitor, 6.3V, X5R, Size 0603	2
R1	CRCW06031002K0FKEA	Vishay ⁽²⁾	10kΩ, 1%, Size 0603	1
L1	VLS3010T-1R0N1R9	TDK ⁽¹⁾	1μH, 1.9A, 60mΩ, L3.0mm x W3.0mm x H1.0mm	1
	VLS4012T-1R0N1R6	TDK ⁽¹⁾	1μH, 2.8A, 50mΩ, L4.0mm x W4.0mm x H1.2mm	
	DO2010-102ML	Coilcraft ⁽³⁾	1μH, 1.8A, 162mΩ, L2.0mm x W2.0mm x H1.0mm	
U1	MIC23150-xYMT	Micrel, Inc. ⁽⁴⁾	4MHz 2A Buck Regulator with HyperLight Load™ Mode	1

Notes:

1. TDK: www.tdk.com.
2. Vishay: www.vishay.com.
3. Coilcraft: www.coilcraft.com.
4. Micrel, Inc.: www.micrel.com.

PCB Layout Recommendations

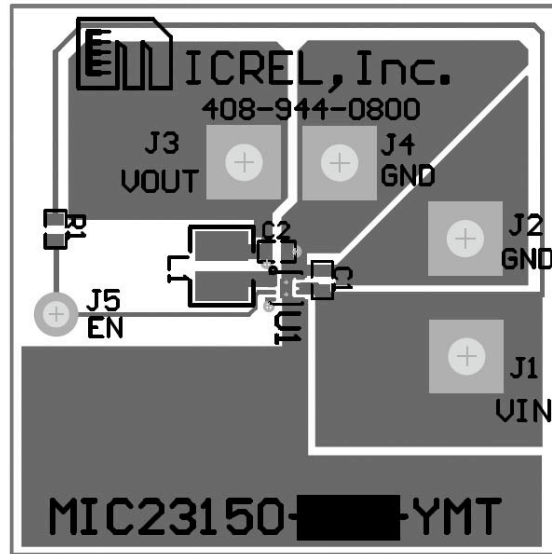

Top Layer

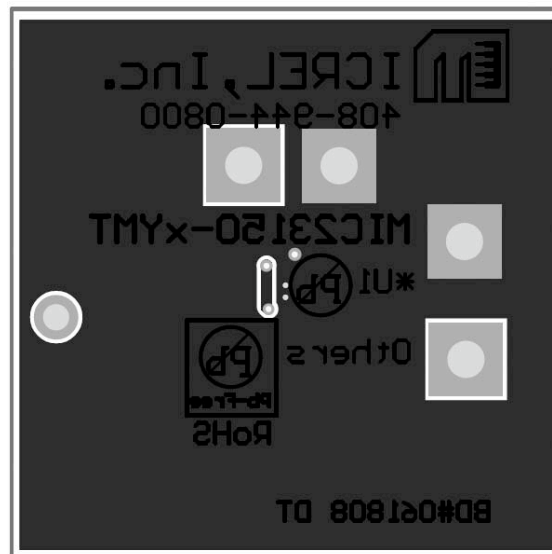

Bottom Layer

MICREL, INC. 2180 FORTUNE DRIVE SAN JOSE, CA 95131 USA
TEL +1 (408) 944-0800 FAX +1 (408) 474-1000 WEB <http://www.micrel.com>

The information furnished by Micrel in this data sheet is believed to be accurate and reliable. However, no responsibility is assumed by Micrel for its use. Micrel reserves the right to change circuitry and specifications at any time without notification to the customer.

Micrel Products are not designed or authorized for use as components in life support appliances, devices or systems where malfunction of a product can reasonably be expected to result in personal injury. Life support devices or systems are devices or systems that (a) are intended for surgical implant into the body or (b) support or sustain life, and whose failure to perform can be reasonably expected to result in a significant injury to the user. A Purchaser's use or sale of Micrel Products for use in life support appliances, devices or systems is a Purchaser's own risk and Purchaser agrees to fully indemnify Micrel for any damages resulting from such use or sale.

© 2009 Micrel, Incorporated.