

# Express-HRR

Extreme Rugged™ COM Express® Type 6 Computer-on-Module with Intel® Core™ i7/i5/i3 processor and QM67 Chipset



## Features

- Quad/dual core Intel® Core™ i7/i5/i3 Processor
- Intel® QM67 Chipset
- Up to 16GB ECC 1333MHz DDR3 memory in two SODIMM sockets
- Three Digital Display Interfaces (DDI) for DisplayPort /HDMI/DVI/SDVO
- Seven PCIe x1, one PCIe x16 (Gen2) for graphics (or general purpose x8/4/1)
- Two SATA 6 Gb/s, two SATA 3 Gb/s, Gigabit Ethernet, eight USB 2.0
- COM Express® COM.0 R2.1 Type 6 Pinout
- Extended Temperature: -40°C to +85°C
- 50% Thicker PCB for high vibration environments

## Choose Ampro by ADLINK™ Express-HRR for...

A modular and power efficient solution for extreme rugged and mobile environments.

### Description

The Ampro by ADLINK™ Express-HRR is a COM Express® Type 6 module with quad/dual-core 2nd Generation Intel® Core™ i7/i5/i3 Processor. The Express-HRR is designed Extreme Rugged to support the extremes of shock, vibration, humidity, and temperature.

## Specifications

### Core System

CPU	2nd Generation Intel® Core™ i7, 32 nm process, BGA type Intel® Core™ i7-2715QE 2.1 GHz (3.0 GHz Turbo), 6MB L3 cache, 45W Intel® Core™ i7-2655LE 2.2 GHz (2.9 GHz Turbo), 4MB L3 cache, 25W Intel® Core™ i7-2610UE 1.5 GHz (2.4 GHz Turbo), 4MB L3 cache, 17W Intel® Core™ i5-2515E 2.5 GHz (3.1 GHz Turbo), 3MB L3 cache, 35W Intel® Core™ i3-2340UE 1.3 GHz, 3MB L3 cache, 17W Intel® Celeron® 847E 1.1 GHz, 2MB L3 cache, 17W Intel® Celeron® 807UE 1.0 GHz, 1MB L3 cache, 10W
Memory	Dual channel ECC 1333 MHz DDR3 memory up to 16 GB in dual SODIMM sockets
BIOS	AMI EFI with CMOS backup in 16 Mb SPI flash
Hardware Monitor	Supply voltages and CPU temperature
Debug Interface	XDP SFF-26 extension for ICE debug
Watchdog Timer	Programmable timer range to generate RESET
Expansion Busses	PCI Express x16 (Gen2) bus for discrete graphics solution or general purpose PCI Express (2 x8 or 1 x8 with 2 x4) 8 PCI Express x1: Lanes 0/1/2/3/4/5/6 are free, lane 7 is occupied by GbE LPC bus, SMBus (system), I2C (user)

### Multi I/O

Chipset	Integrated on QM67
USB	Supports up to eight ports USB 2.0
SATA	Two SATA 6 Gb/s, two SATA 3 Gb/s with support for RAID 0,1,5,10

### LAN

Chipset	Intel® Gigabit LAN PHY WG82579LM
Speed	10/100/1000 Mbps Ethernet

### Video

Integrated in Processor	HD Graphics 3000 at 650-1300 MHz
Integrated Video	DirectX 10.1 and OpenGL 3.0
Feature Support	Intel® Clear Video HD Technology Advanced Scheduler 2.0, 1.0, XPDM support DirectX Video Acceleration (DXVA) support for full AVC/VC1/MPEG2 hardware decode
VGA Interface	Analog VGA support with 300 MHz DAC Analog monitor support up to QXGA (2048 x 1536) and VGA hot plug
LVDS Interface	Dual channel 18/24-bit LVDS
Digital Display Interface	Three DDI ports supporting HDMI / DVI / DisplayPort or SDVO

### Audio

Chipset	Integrated on Intel® PCH QM67
Audio Codec	Implemented on carrier board

### Super I/O

Connected to LPC bus on carrier if needed

### TPM

Chipset	Atmel AT97SC3204
Type	TPM 1.2

### Power Specifications

Input Power	AT mode (12 V +/- 5%) and ATX mode (12 V and 5 Vsb +/- 5%)
Power States	Supports S0, S1, S3, S4, S5
Power Consumption	TBD
Smart Battery Support	Yes

### Mechanical and Environmental

Size	COM Express Basic, 125 mm x 95 mm
Board Thickness	0.093" (2.3mm)
Operating Temp. Standard	-20°C to 70°C
Operating Temp. Extended	-40°C to 85°C (not available for Core™ i7-2715QE)
Storage Temp.	-55°C to 85°C
Humidity	90% at 60°C non-condensing
Shock	50G peak-to-peak, 11ms duration, MIL-STD-202G Method 213B
Vibration	Operating: 11.96 Grms, 50-20,000 Hz, each axis, MIL-STD-202G Method 214A
Compatibility	PICMG COM Express COM.0 R2.1 Type 6
Certifications	CE, FCC, HALT

### Operating Systems

Standard Support	Windows 7, Linux
Extended Support (BSP)	WES 2009/7, WEC 7, Linux, VxWorks 6.9, QNX 6.5, AIDI Library

## Functional Diagram

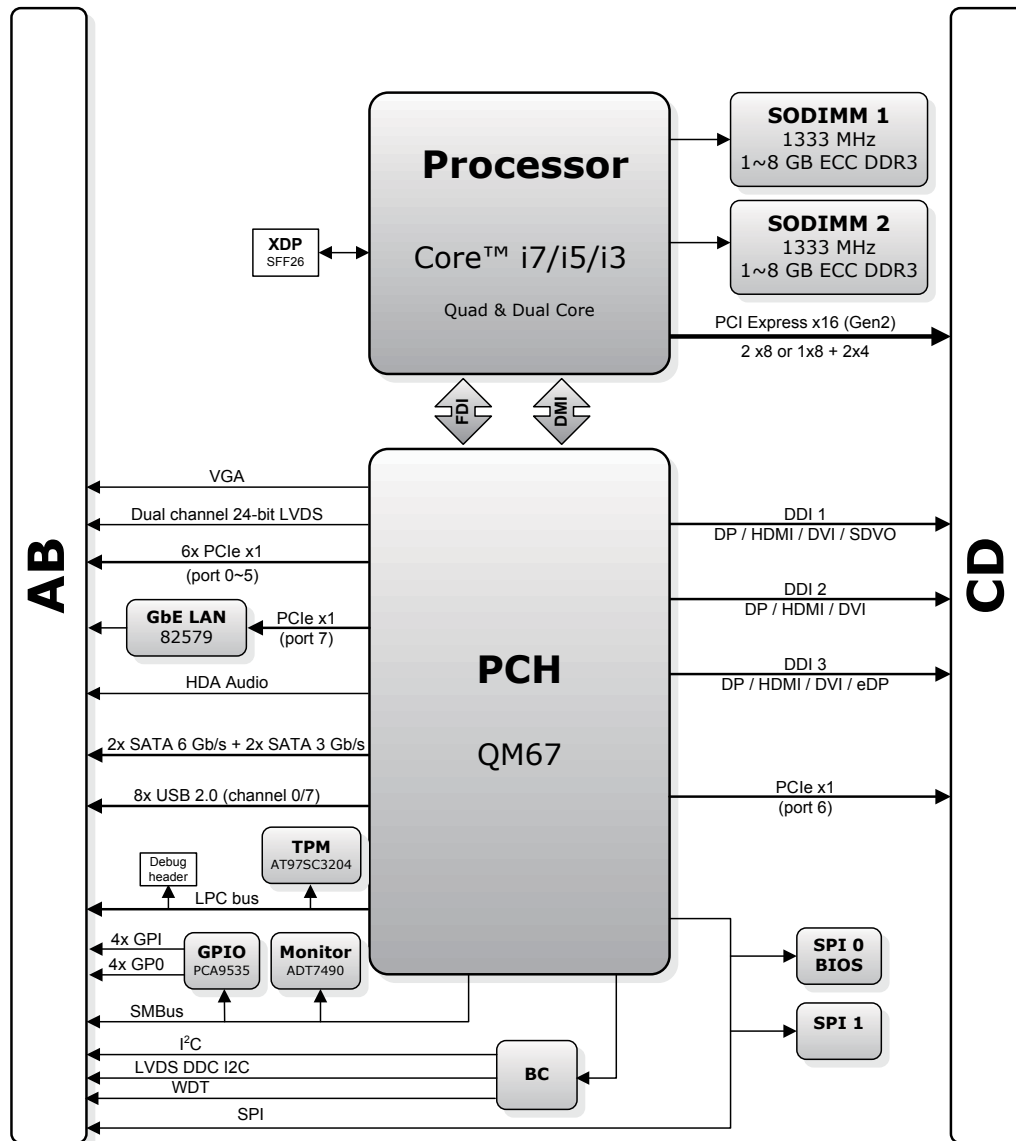

## Ordering Information

### Modules

Model Number	Description/Configuration
Express-HRR-i7-R-2715QE	Extreme Rugged COM Express Type 6 module with Intel® Core™ i7-2715QE Quad Core processor 2.1GHz 45W with QM67 chipset (Ext. Temp. not available)
Express-HRR-i7-R-2655LE	Extreme Rugged COM Express Type 6 module with Intel® Core™ i7-2655LE Dual Core processor 2.2GHz 25W with QM67 chipset
Express-HRR-i7-R-2610UE	Extreme Rugged COM Express Type 6 module with Intel® Core™ i7-2610UE Dual Core processor 1.5GHz 17W with QM67 chipset
Express-HRR-i5-2515E	Extreme Rugged COM Express Type 6 module with Intel® Core™ i5-2515E Dual Core processor 2.5GHz 35W with QM67 chipset
Express-HRR-i3-R-2340UE	Extreme Rugged COM Express Type 6 module with Intel® Core™ i3-2340UE ULV Dual Core processor 1.3GHz 17W with QM67 chipset
Express-HRR-R-847E	Extreme Rugged COM Express Type 6 module with Intel® Celeron® 847E LV Dual Core processor 1.1GHz 17W with QM67 chipset

Model Number	Description/Configuration
Express-HRR-R-807UE	Extreme Rugged COM Express Type 6 module with Intel® Celeron® 807UE ULV Single Core processor 1.0GHz 10W with QM67 chipset
Express-HRR-i7-L-M8G	Starterkit with 2x 4GB DDR3 ECC RAM, non-ETT, cable kit, Software (no CPU module and heatsink included)
Express-HRR-i7-L-M4G	Starterkit with 2x 2GB DDR3 ECC RAM, non-ETT, cable kit, software (no CPU module and heatsink included)

### Accessories

#### Heat Spreaders

HTS-HRR-BTF	Heatspreader for Express-HRR with through hole standoffs for top mounting
-------------	---

#### Passive Heatsinks

THSH-HRR-BTL	Heatsink for Express-HRR with through hole standoffs for top mounting
--------------	---

#### Active Heatsinks

THSF-HRR-BTL-CU	Heatsink with FAN for Express-HRR with through hole standoffs for top mounting
-----------------	--