

## Dual Relay Board Kit (#27114)

The Dual Relay Board can be used to turn lights, fans and other devices on/off while keeping them isolated from your microcontroller. Once properly assembled, the Dual Relay Board Kit allows you to control two high-power devices (up to 8 A) via the included Omron mechanical relays. Independent control of each relay is provided via a 2 x 3 header — friendly to servo cables and convenient connection to many development boards, such as the Board of Education, Propeller Board of Education, Professional Development Board and Propeller Professional Development Board. LEDs indicate relay status.

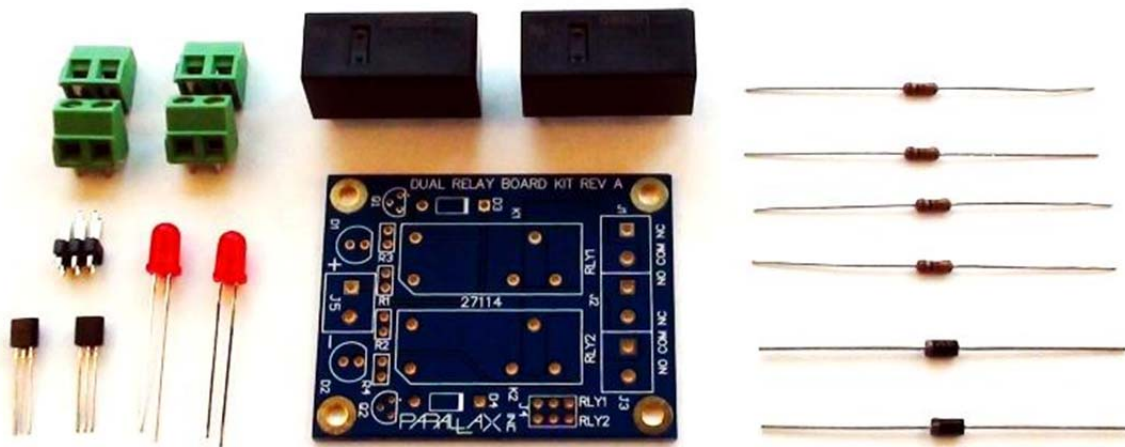

### Features

- Control two high-power devices at up to 8 A each with one kit
- Provides isolation between microcontroller and device being controlled
- Screw terminals for relay connections
- 3-pin servo-style headers for signal interface
- LED indicators for each relay

### Key Specifications

- Power Requirements: 12 VDC @ 85 mA (nominal)
- Communication Interface: Logic (3.3 V/5 V) High/Low
- Operating temperature: -40 to +185 °F (-40 to +85 °C)
- Dimensions: 2.3" L x 1.8" W x 0.7" H (58.4 x 45.8 x 1.8 cm)

### Application Ideas

- 120 VAC brushless lighting/fan control
- 12 VDC automotive applications

## Bill of Materials

Designator	Description	Quantity	Part #
J1-J4	2 Position Screw Terminal Block	4	452-00012
J5	Connector, Header, 2x3, 0.1", Straight	1	450-00105
K1-K2	Omron Relay G2RL-14-DC12, SPDT, 12A, 12VDC	2	400-00052
R1-R4	Resistor, 1K, 5%, 1/4W, CF	4	150-01020
D1-D2	LED, Red, T1-3/4	2	350-00006
D3-D4	1N4004 Diode, Rectifier, 1V, 400V, 1A, Axial	2	501-00006
Q1-Q2	2N3904 NPN Transistor, TO-92	2	500-00008
PCB1	Raw PCB, Dual Relay Board	1	300-27114

## Additional Items Required

- Soldering iron
- Solder
- Diagonal cutters
- Safety glasses

## Assembly Instructions

### Step 1

Install the lower profile components first (D1-D2, D3-D4, R1-R4 and Q1-Q2).

When installing D1-D2 (Red LED), be sure the flat side of the LED lines up with the flat side on the silkscreen.

When installing D3-D4 (1N4004 Diode), be sure the stripe lines up with the stripe on the silkscreen.

When installing Q1-Q2 (2N3904 NPN Transistor), be sure the flat face lines up with the flat side on the silkscreen.

Resistors R1-R4 are not polarized and can be mounted in either direction, however you will have to bend one lead over to install the resistors upright. See the photo at right for details.

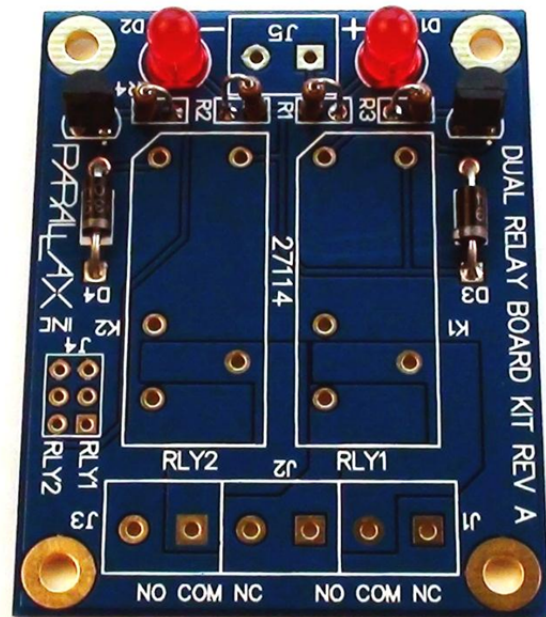

### Step 2

Install the connectors next (J1-J3, J4 and J5).

When installing J1-J3 (green terminal blocks), be sure to connect these three together by sliding them into each other using the tab/groove before installing onto the PCB. Wire holes should be facing the outside of the PCB.

J5 (remaining green terminal block) is by itself at the opposite end of the board. Wire holes should be facing the outside of the PCB.

J4 should be installed with the shorter end of the pins being inserted into the PCB.

See the photo at right for details.

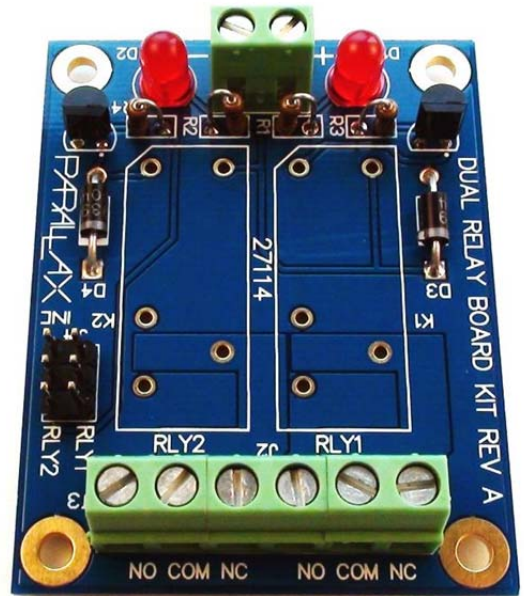

### Step 3

Install the relays last (K1-K2).

Be sure the relays are fully seated into the holes before you begin soldering.

See the photo at right for details.

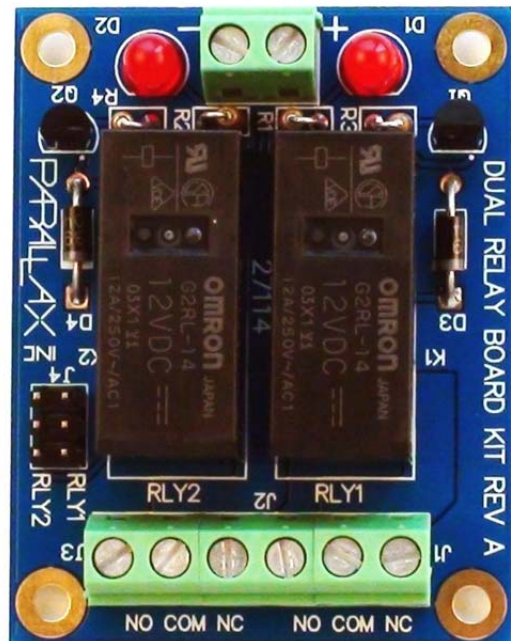

## Precautions

As with any device capable of switching high voltages, precautions should always be taken to avoid damage and/or injury. The following precautions are recommended in addition to any precautions by the manufacturer of any equipment connected to this device.

- Always disconnect main power when connecting circuits to the Dual Relay Board.
- Download and read the relay datasheet from the 27114 product page before using the relays.
- When using with high-power circuits, mount the Dual Relay Board inside a suitable enclosure or electrical panel using standoffs. The board should not be able to move.
- Secure all electrical connections to the board so they cannot move; provide strain relief for any wires extending outside the enclosure.
- Fuse any incoming voltage rails that are to be switched by the relays, prior to entering the Dual Relay Board.
- Always be sure any incoming voltage rails are powered off prior to connecting them to the Dual Relay Board.
- Observe Max Switching Current listed below! The Relays are capable of switching more current than the Terminal Blocks and PCB can handle.
- While mechanical relays provide physical electrical isolation from control circuits, it is possible for EMF generated by high-power devices to affect the control circuits. This is especially true if the control wires and/or power leads are longer than 6". Always try to keep wires as short as possible and avoid running high-power leads near or across control lines.

## Pin Definitions and Ratings (J4)

Pin	Name	Type	Function
1	Relay 1	I	Relay 1 Signal Input (3.3V/5V)*
2	Relay 2	I	Relay 2 Signal Input (3.3V/5V)*
3	NC	—	No Connection
4	NC	—	No Connection
5	GND	G	Signal/Relay Coil Ground
6	GND	G	Signal/Relay Coil Ground

Pin Type: P = Power, G = Ground, I = Input, O = Output

\*Inputs signals on pin 1 and 2 are typically 3.3 V or 5 V but are independent and do not need to be the same. For example Relay 1 could be switched via a 3.3 V control signal while Relay 2 could be switched via a 5 V control signal.

## Specifications

Symbol	Quantity	Minimum	Typical	Maximum	Units
12V	Relay Supply Voltage	7	12	—	V
—	Relay Supply Current	—	85	—	mA
—	Max Switching Current	—	—	8	A

## Module Dimensions / Connection Diagram

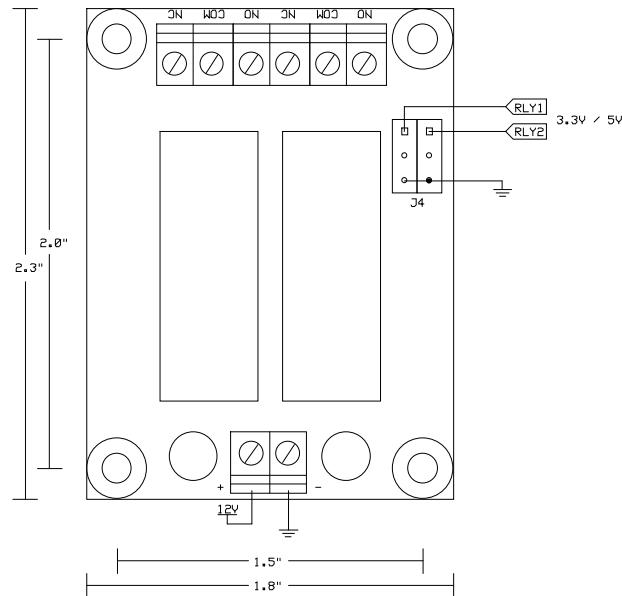

Note: The two pins at the J4 (pins 5/6) label are both ground pins, while the pins labeled RLY1 and RLY2 (pins 1/2) are the signal/control pins. Pins 3 and 4 are no connected but allowed you to connect a powered servo cable without a conflict with the servo supply.

## Theory of Operation

In the schematic details to the right the red box is intended to encapsulate one complete relay circuit to help show how the relay driver circuit is built and what components are required.

One complete relay circuit consists of 1/2 of J4, R3, Q1, D1, R1, D3 and K1. J5 supplies voltage to K1 at port 12 V. The relay (K1) requires approximately 33 mA to activate. This is more than most I/O pins on a microcontroller can source/sink, so a transistor (Q1) is used to drive the relay.

Q1 is a standard NPN switching/amplifier transistor with a usable current rating of 100 mA, which is well within the requirements for the relay (~33 mA) and LED (~10 mA). The gain ( $h_{FE}$ ) of this transistor may vary but is typically 100, while the minimum is 30. The  $V_{BE}$  (forward voltage) of Q1 is about 0.7 V, so to allow a range of control voltages the resistor (R3) must be chosen carefully.

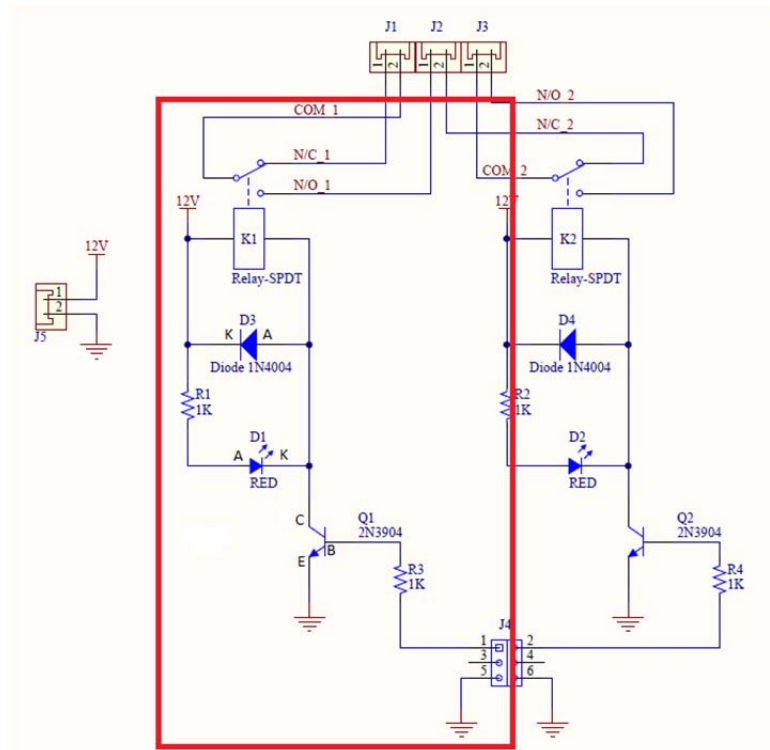

In order to fully saturate (turn on) and provide the necessary current across the C-E junction the transistor's B-E junction draws a relative amount of current based on the minimum gain ( $h_{FE}$ ). It is a good idea to limit the control current to a few mA at most and allow a range of control voltages from at least 3.3 V through 5 V. The formula to calculate the base current is  $I_B = (V_{DD} - V_{BE}) / R_B$ , where  $V_{DD}$  is the control voltage,  $V_{BE}$  is the forward voltage of the transistor and  $R_B$  is the resistance in ohms. If the control signal is 3.3 V, with R3 being 1 K then  $(3.3 - 0.7) / 1000 = 3$  mA. At 5 V the current is ~4 mA.

Three additional components make up one relay circuit (R1, D1 and D3). R1 is the current limiting resistor for D1, which is a Red LED to indicate when the relay is energized. The value of 1K has been chosen to allow the LED to operate at a safe minimum current when the relay voltage is a little high or low from the nominal 12 V. D3 is designed to snub back EMF from the relay coil when the relay turns off. This protects Q1 from potentially damaging voltage transients caused by K1. Note the position of the Anode (A) and Cathode (K) of D3. It is designed not to conduct during normal operation (when the relay is powered). Q1 is switching the relay (K1 in parallel with D3) as well as the red LED (D1 / R1).

The relay output is SPDT (single-pole, double-throw), which means it has a single common lead (COM) that can connect to one of two switched leads, NO (normally open) or NC (normally closed). The normal state is in reference to the off state of the relay. When the relay is off, COM is connected to NC while NO is disconnected. When the relay is energized, COM is connected to NO and NC is disconnected. The typical way to turn on a device with the relay board is to connect the power source you want to switch to the COM connection on one of the relays and the NO connection to the power (hot) lead of the device being switched. A mechanical relay provides physical isolation of the switching circuit and the circuit being switched since there is no electrical connection between the two circuits.

The output terminals of each relay are electrically equivalent to a SPDT switch and can be used in the same manner. You can also switch two devices that use the same power source by connecting the power source to the COM connections on both relays.

## Resources and Downloads

Check for the latest version of this document, schematic diagram and relay datasheet from the Dual Relay Board Kit product page. Go to [www.parallax.com](http://www.parallax.com) and search 27114.

## BASIC Stamp<sup>®</sup> Example Code

This program activates each relay and then turns them both off at one second intervals. RLY1 should be connected to P14 and RLY2 to P15. If you're using the Board of Education you can use servo cables and plug them directly into the X4 headers on the board. If you're powering your Board of Education with a 9 V or 12 V power supply (or a 9V battery) you can get the relay power from  $V_{IN}$  and  $V_{SS}$  to J5 + and - on the Dual Relay Board. The relays are rated to operate at 70% of the nominal supply voltage or 8.4 V.

```
' {$STAMP BS2}
' {$PBASIC 2.5}

RLY1 PIN 14
RLY2 PIN 15

DO
  HIGH RLY1
  PAUSE 1000
  HIGH RLY2
  PAUSE 1000
  LOW RLY1
  LOW RLY2
  PAUSE 1000
LOOP
```

## Propeller P8X32A Example Code

This program activates each relay and then turns them both off at one second intervals. RLY1 should be connected to P0 and RLY2 to P1. J5 of the Dual Relay Board should be supplied with 12 VDC. Depending on the Propeller board used, if you are powering the board with a 9 V or 12 V power supply (or a battery) you can get the relay power from VIN and VSS to J5 + and - on the Dual Relay Board. The relays are rated to operate at 70% of the nominal supply voltage or 8.4 V.

```
'' 27114 Dual Relay Board Kit   Spin Example

CON

  _CLKMODE = XTAL1 + PLL16X      ' Use crystal x 16
  _XINFREQ = 5_000_000          ' 5 MHz crystal (system clock = 80
MHz)

CON

  RLY1 = 0                      ' Propeller pin connected to RLY1
  RLY2 = 1                      ' Propeller pin connected to RLY2

PUB Main

  dira[RLY2..RLY1] := %11      ' Set P0/P1 to output

  repeat                        ' Loop indefinitely
    outa[RLY1]~~               ' Turn on Relay 1
    waitcnt(clkfreq + cnt)     ' Pause 1 second
    outa[RLY2]~~               ' Turn on Relay 2
    waitcnt(clkfreq + cnt)     ' Pause 1 second
    outa[RLY1]~                ' Turn off Relay 1
    outa[RLY2]~                ' Turn off Relay 2
    waitcnt(clkfreq + cnt)     ' Pause 1 second
```