

# Bipolar Stepper Motor Driver™

# Manual

*All Mikroelektronika's development systems feature a large number of peripheral modules expanding microcontroller's range of application and making the process of program testing easier. In addition to these modules, it is also possible to use numerous additional modules linked to the development system through the I/O port connectors. Some of these additional modules can operate as stand-alone devices without being connected to the microcontroller.*

**Additional board**

 **MikroElektronika**

SOFTWARE AND HARDWARE SOLUTIONS FOR EMBEDDED WORLD ...making it simple

## Bipolar Stepper Motor Driver

The *Bipolar Stepper Motor Driver* additional board is designed to operate bipolar stepper motors in full-, half-, quarter- and eight-step modes. It is available as a stand-alone device or connected to the microcontroller. For connecting the *Bipolar Stepper Motor Driver* to the microcontroller on the development system, it is necessary to use a flat cable with regular IDC female connector that should be connected to some development system's I/O port.

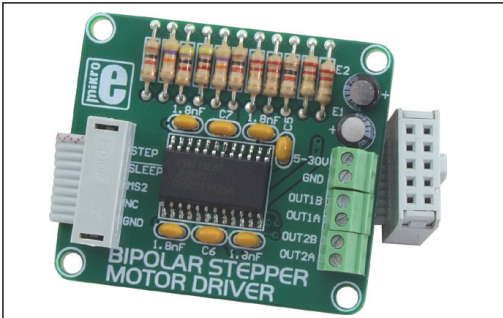

Figure 1: Bipolar Stepper Motor Driver

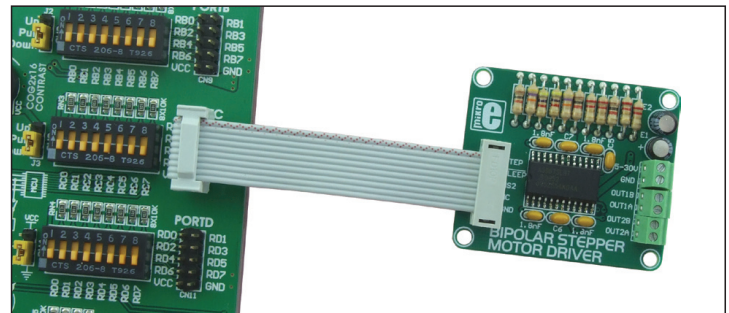

Figure 2: Bipolar Stepper Motor Driver connected to a development system

The operation of the *Bipolar Stepper Motor Driver* is based on the A3967SLB circuit. It is an integrated circuit specialized for driving step motors with output driver capability of up to 30V and current up to 750mA. The circuit features thermal shutdown protection, crossover-current protection and under-voltage lockout. Its operation mode depends on the logic state of 7 input pins. Their functions are illustrated in Table 1.

Input	Active state	Function
ENABLE#	0	This active-low input enables all of the outputs.
STEP	0-1	A low-to-high transition on this input advances the motor one increment. The size of the increment is determined by the state of inputs MS1 and MS2.
RESET#	0	This active-low input turns off all of the outputs. STEP inputs are ignored until the RESET input goes high.
SLEEP#	0	This active-low control input is used to minimize power consumption when not in use.
MS1	0/1	Select the microstepping format as per Table 2.
MS2	0/1	Select the microstepping format as per Table 2.
DIR	0/1	The state of this input determines the direction of rotation of the motor.

Table 1: Bipolar Stepper Motor Driver input pins' functional description

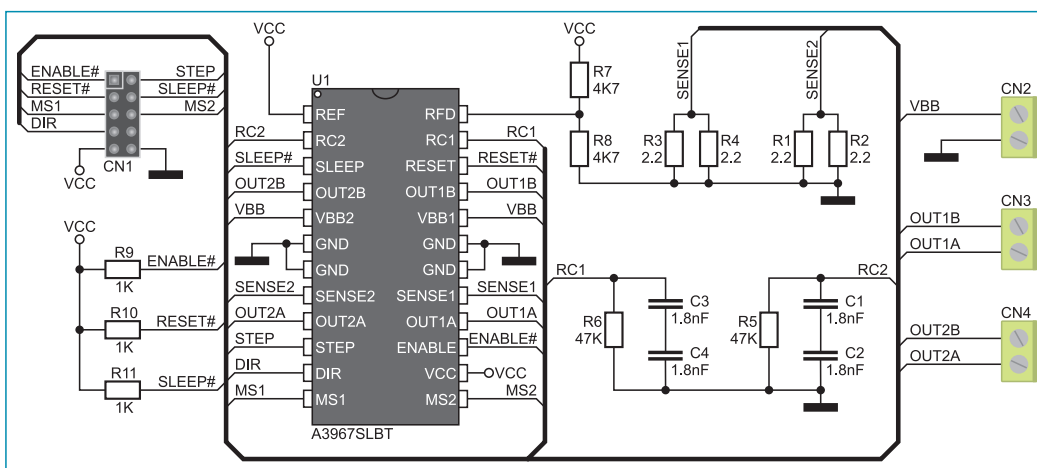

Figure 3: Bipolar Stepper Motor Driver connection schematic

Bipolar stepper motors' stator features two independent coils (A and B). Their ending terminals should be connected to the CN3 and CN4 connectors (OUT1A, OUT1B, OUT2A and OUT2B pins). A voltage used for driving these coils is supplied on the CN2 connector and amounts to up to 30V.

# Bipolar Stepper Motor Driver

The *Bipolar Stepper Motor Driver* additional board enables you to drive the motor in various step modes. The size of one increment (resolution) is equal to a movement of rotor generated by one pulse on step input. The resolution is determined by logic state on MS1 and MS2 inputs as shown in Table 2.

MS1	MS2	Resolution
0	0	Full step
1	0	Half step
0	1	Quarter step
1	1	8 Microstep

**Table 2:** Resolution Truth Table

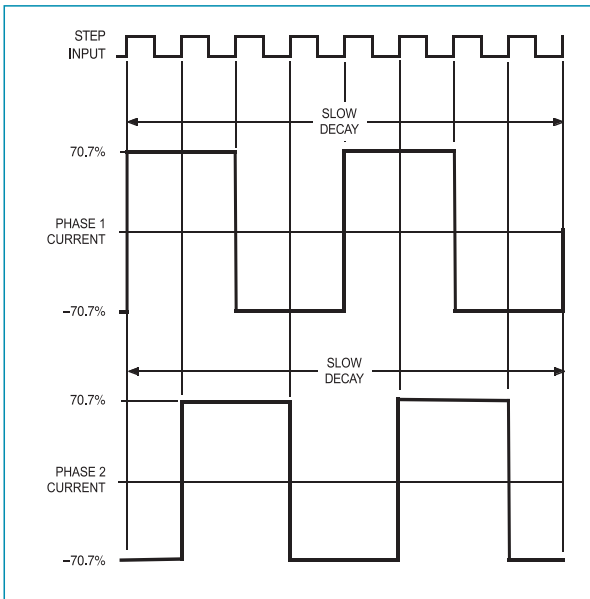

**Figure 4:** Full Step mode: MS1=0, MS2=0, DIR=1

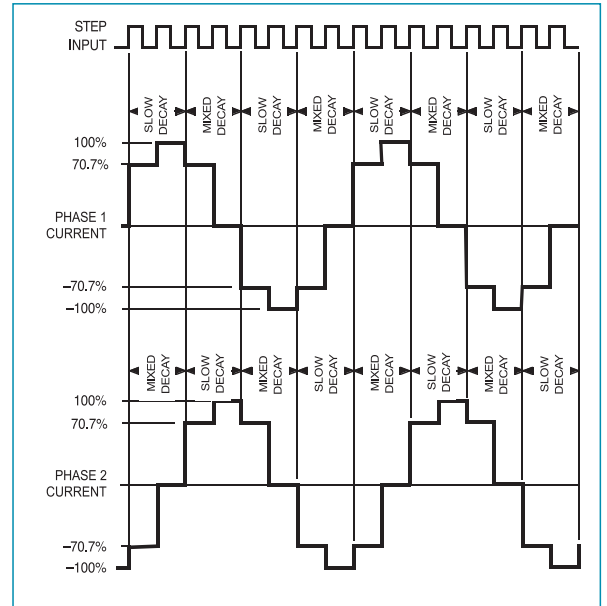

**Figure 5:** Half Step mode: MS1=1, MS2=0, DIR=1

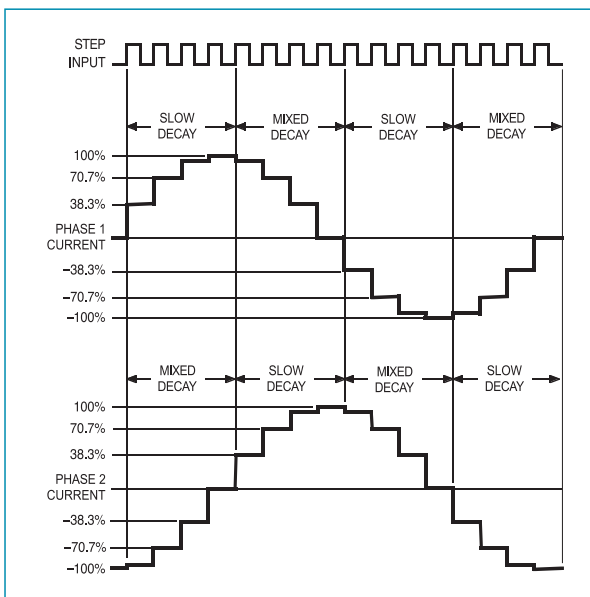

**Figure 6:** Quarter Step mode: MS1=0, MS2=1, DIR=1

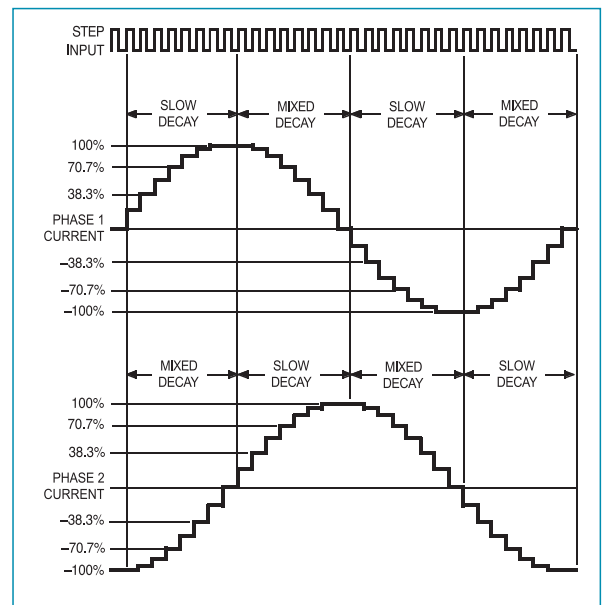

**Figure 7:** 8 Microstep mode: MS1=1, MS2=1, DIR=1