

# EasyAVR™ v7

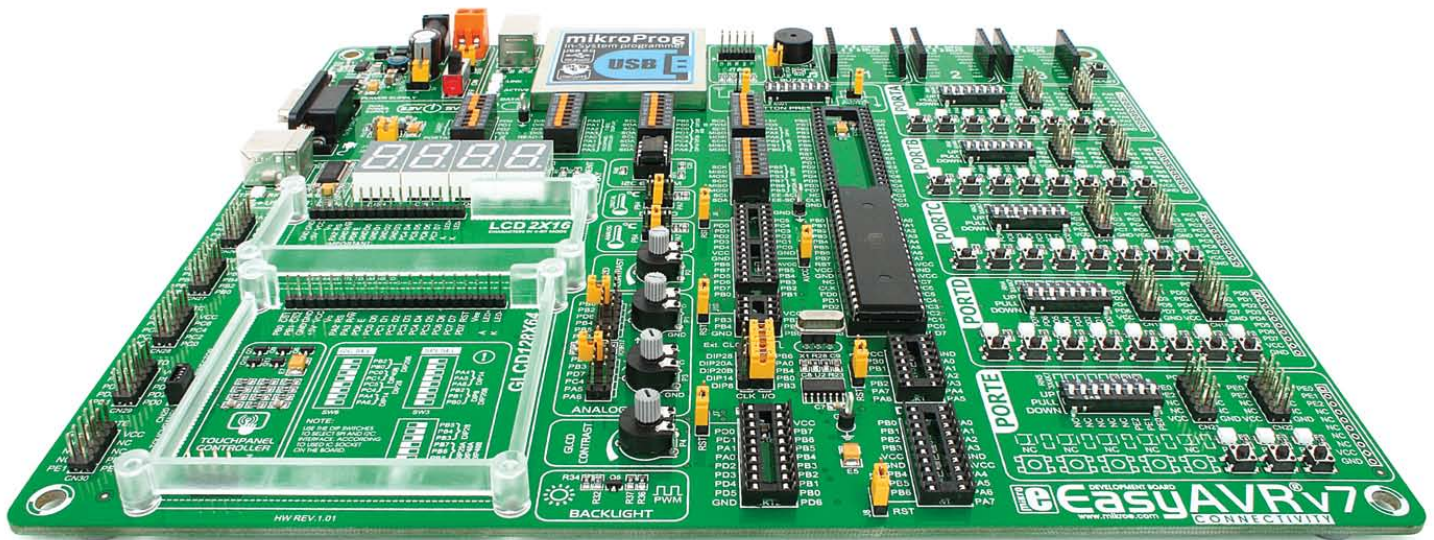

## 65

microcontrollers supported  
The ultimate AVR® board

DUAL POWER SUPPLY  
3.3V 5V

Supports 3.3V and 5V devices  
Dual Power Supply

mikro  
BUS

Easily add extra boards  
mikroBUS™ sockets

connectivity  
↑↓

Four connectors for each port  
Amazing Connectivity

USB E

As fast as it gets  
USB 2.0 programmer

**MikroElektronika**  
DEVELOPMENT TOOLS | COMPILERS | BOOKS

# To our valued customers

Making the best and the most comprehensive AVR® board in the world was our idea from the start. And this is by no means an easy task. Driven by passion for excellence we never look at how hard the job is, but what our users get when it's done. And EasyAVR® v7 brings a whole new perspective to AVR developers.

The 7th generation of the board brings many exciting new features. We hope that you will like it as much as we do.

Use it wisely and have fun!



Nebojsa Matic,  
Owner and General Manager  
of mikroElektronika

# Table of contents

## Introduction

Introduction .....	04
It's good to know .....	05

## Power Supply

Dual power supply .....	06
-------------------------	----

## Supported MCUs

Supported microcontrollers .....	08
----------------------------------	----

## Programming

On-board programmer .....	10
Installing programmer drivers .....	12
Programming software .....	13

## Communication

UART via RS-232 .....	14
UART via USB .....	15

## Connectivity

mikroBUS™ sockets .....	16
Input/Output Group .....	18

## Displays

LCD 2x16 characters .....	20
GLCD 128x64 .....	21
Touch panel controller .....	22
4 digit 7-seg display .....	23

## Modules

DS1820 - Digital Temperature Sensor .....	24
LM35 - Analog Temperature Sensor .....	25
ADC inputs .....	26
I2C EEPROM .....	27
Piezo Buzzer .....	28
Additional GNDs .....	29

## What's next

What's Next? .....	30
--------------------	----

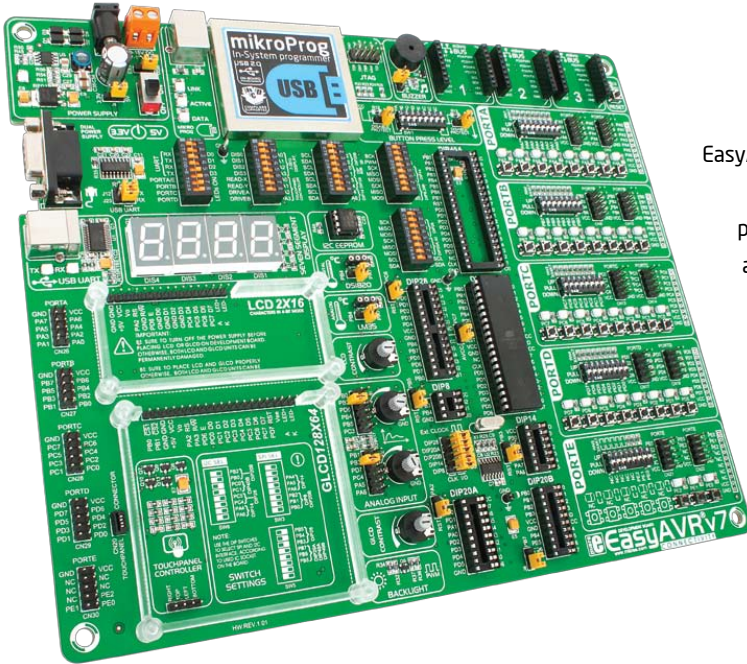

# Introduction

EasyAVR™ is your old friend. It has been here for you for several generations.

Today it has many users among students, hobbyists, enthusiasts and professionals. We asked ourselves what else could be done to make such a great board even greater. As a result some brilliant changes have been made. We focused all of our creativity and knowledge on making a revolutionary new design different from any previous version of the board. We have gone through the process of fine tuning the board performance, and used 4-layer PCB to achieve maximum efficiency. We now present you with the new version of EasyAVR - a powerful, well organized board with on-board programmer - ready to be your strong ally in development.

*EasyAVR™ development Team*

## Four Connectors for each port Amazing connectivity

EasyAVR™ v7 is all about connectivity. Having four different connectors for each port, you can connect accessory boards, sensors and your custom electronics easier than ever before.



## Everything is already here mikroProg™ on board

Powerful on-board mikroProg™ programmer can program about 65 AVR® microcontrollers from Atmel®. You will need it, whether you are a professional or a beginner.



## 3.3V and 5V power supply Dual Power Supply

EasyAVR™ v7 is among few development boards which support both 3.3V and 5V microcontrollers. This feature greatly increases the number of supported MCUs. It's like having two boards instead of one!



## For easier connections mikroBUS™ support

Just plug in your Click™ board, and it's ready to work. We picked up a set of the most useful pins you need for development and made a pinout standard you will enjoy using.



# It's good to know

## ATmega32 is the default microcontroller!

Atmel® AVR® 8-bit ATmega32 in DIP is the default chip of EasyAVR™ v7. It has up to **16 MIPS** operation, **32K bytes** of Flash program memory, **2K byte** of internal SRAM memory and **1K byte** of EEPROM memory. It has 40-pin with 32 General purpose **I/O pins**, 10-bit Analog-to-Digital converter with up to 8 channels (**ADC**), two 8-bit and one 16-bit timers/counters (with separate prescalers, compare mode and capture mode), four PWM channels, programmable serial **USART**, Master/slave **SPI** and two-wire **I<sup>2</sup>C** interface, internal calibrated 8 MHz RC and 32 KHz RTC oscillator. It also has JTAG interface for programming/debugging.

- Great choice for both beginners and professionals
- Rich with modules
- Enough RAM and Flash
- Comes with examples for mikroC, mikroBasic and mikroPascal compilers



## System Specification



**power supply**  
7-12V AC or 9-15V DC  
or via USB cable (5V DC)



**power consumption**  
~80mA when all peripheral  
modules are disconnected



**board dimensions**  
266 x 220mm (10.47 x 8.66 inch)



**weight**  
~438g (0.966 lbs)

## Package contains



- 1** Damage resistant protective box

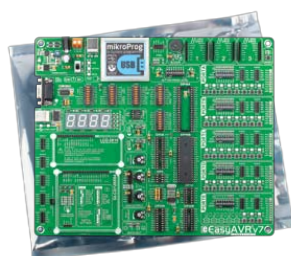

- 2** EasyAVR™ v7 board in antistatic bag



- 3** USB cable



- 4** User Manuals and Board schematic



- 5** DVD with examples and documentation

EasyAVR<sup>v7</sup>

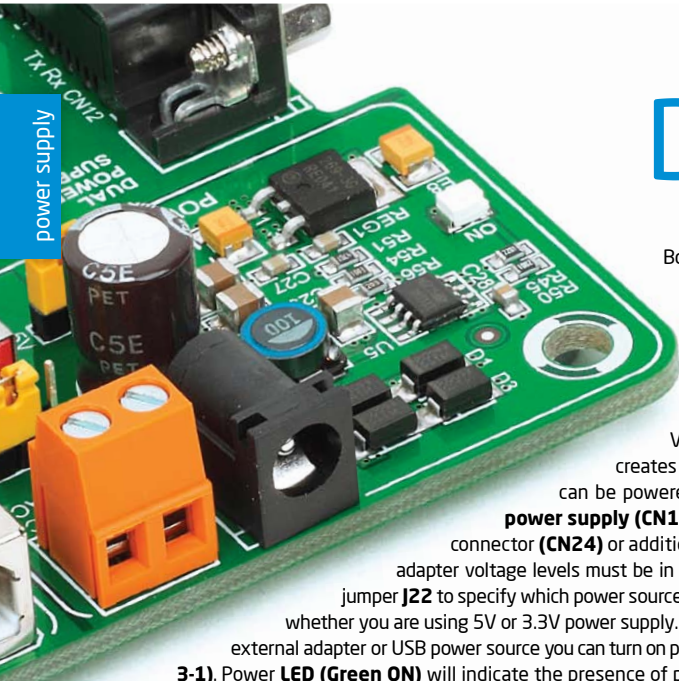

# Dual power supply

Board contains switching power supply that creates stable voltage and current levels necessary for powering each part of the board. Power supply section contains two power regulators: **ST1S10**, which generates VCC-5V, and **MC33269DT3.3** which creates VCC-3.3V power supply. The board can be powered in three different ways: with **USB power supply (CN1)**, using external adapters via adapter connector (**CN24**) or additional screw terminals (**CN25**). External adapter voltage levels must be in range of **9-15V DC or 7-12V AC**. Use jumper **J22** to specify which power source you are using and jumper **J5** to specify whether you are using 5V or 3.3V power supply. Upon providing the power using either external adapter or USB power source you can turn on power supply by using **SWITCH 1 (Figure 3-1)**. Power **LED (Green ON)** will indicate the presence of power supply.

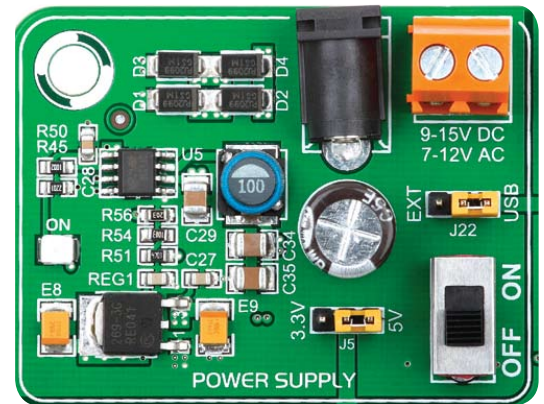

Figure 3-1: Dual power supply unit of EasyAVR™ v7

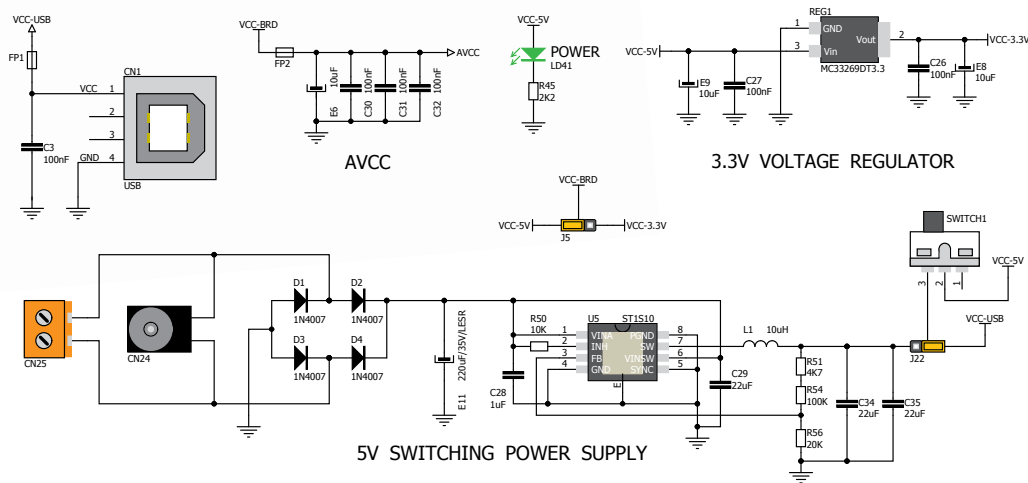

Figure 3-2: Dual power supply unit schematic

## DUAL POWER SUPPLY



EasyAVR™ v7 development board supports both 3.3V and 5V power supply on a single board. This feature enables you to use wide range of peripheral boards.

**Power supply:** via DC connector or screw terminals (7V to 12V AC or 9V to 15V DC), or via USB cable (5V DC)  
**Power capacity:** up to 500mA with USB, and up to 1500mA with external power supply

# How to power the board?

## 1. With USB cable



Set J22 jumper to USB position

To power the board with USB cable, place jumper **J22** in USB position and place jumper **J5** in 5V or 3.3V position. You can then plug in the USB cable as shown on images **1** and **2**, and turn the power switch ON.

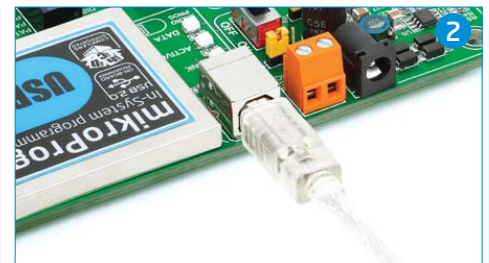
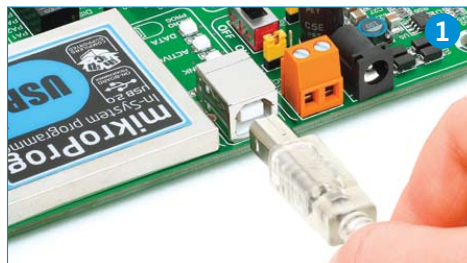

## 2. Using adapter



Set J22 jumper to EXT position

To power the board via adapter connector, place jumper **J22** in EXT position, and place jumper **J5** in 5V or 3.3V position. You can then plug in the adapter cable as shown on images **3** and **4**, and turn the power switch ON.

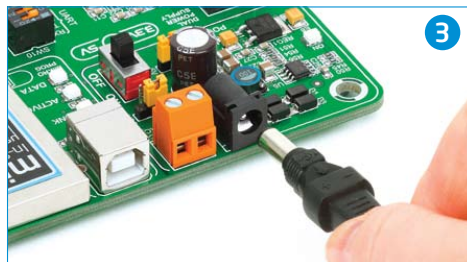

## 3. With laboratory power supply



Set J22 jumper to EXT position

To power the board using screw terminals, place jumper **J22** in EXT position, and place jumper **J5** in 5V or 3.3V position. You can then screw-on the cables in the screw terminals as shown on images **5** and **6**, and turn the power switch ON.

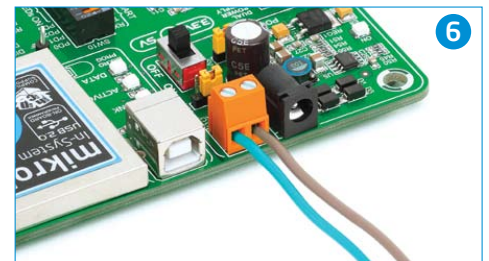
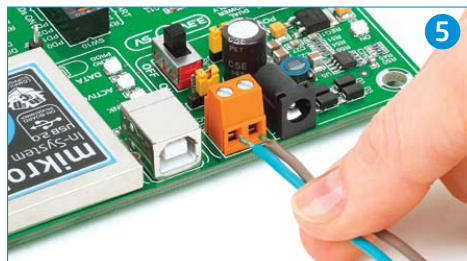

EasyAVR<sup>v7</sup>

# Supported microcontrollers

## Microcontroller sockets

The board contains seven DIP sockets: DIP40A, DIP40B, DIP28, DIP20A, DIP20B, DIP14, DIP8 (Figure 4-1). With dual power supply and smart on-board mikroProg, the board is capable of programming about 65 different microcontrollers from Atmel® AVR family. There are two DIP40 and DIP20 sockets for AVR® microcontrollers provided on the board. Which of these sockets you will use depends solely on the pinout of the microcontroller in use. The **EasyAVR™ v7** development system comes with the **ATmega32** microcontroller in a **DIP40** package.

## AREF jumper

If you use **DIP28** microcontroller socket with jumper **J11** you can set PC7 pin either as AVCC or I/O pin. Jumper **J11** is placed in the AVCC position by default.

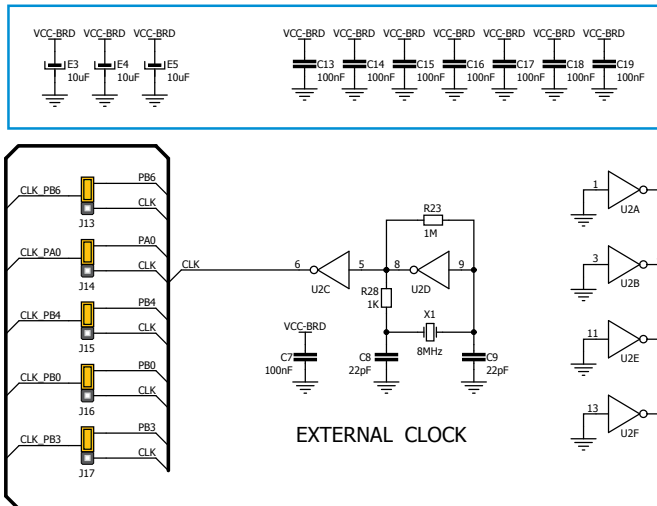
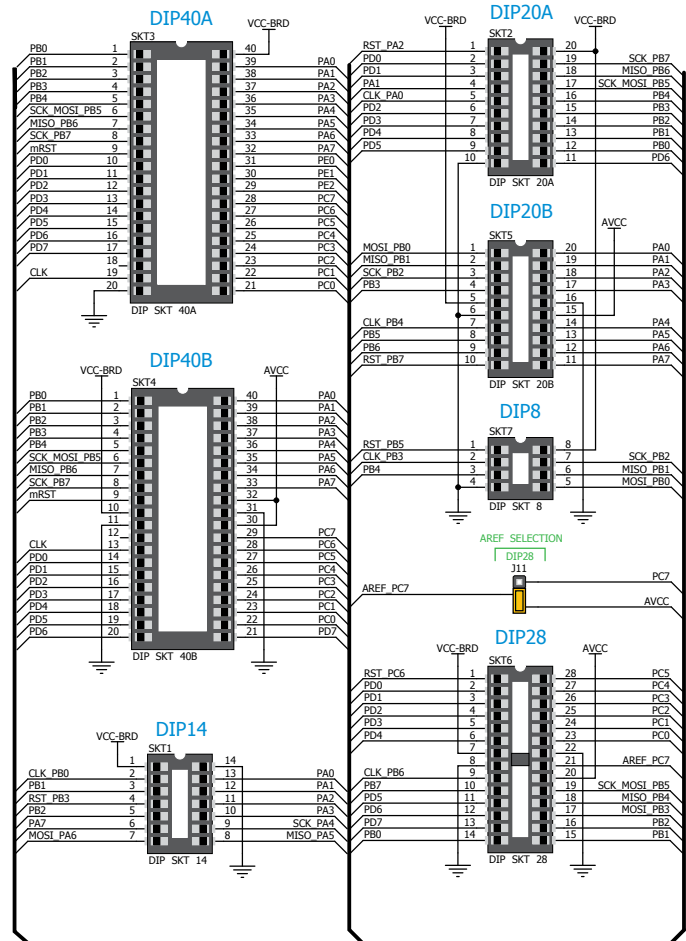
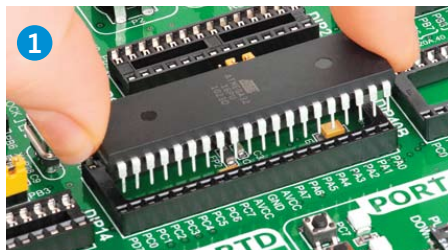

Figure 4-1: Schematic of on-board DIP sockets, quartz-crystal oscillator and decoupling capacitors





## How to properly place your microcontroller into the DIP socket?



**Figure 4-2:** Place both ends of microcontroller on the socket so the pins are aligned correctly

Before you plug the microcontroller into the appropriate socket, make sure that the **power supply is turned off**. Images above show how to correctly plug a microcontroller. First make sure that

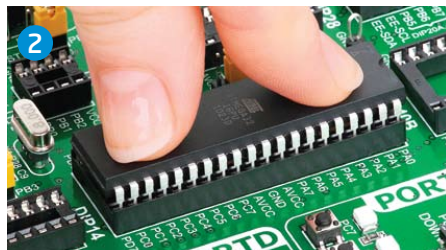

**Figure 4-3:** with both fingers, evenly distribute the force and press the chip into the socket.

a half circular cut in the microcontroller DIP packaging matches the cut in the DIP socket. Place both ends of the microcontroller into the socket as shown in **Figure 4-2**. Then put the microcontroller slowly down until

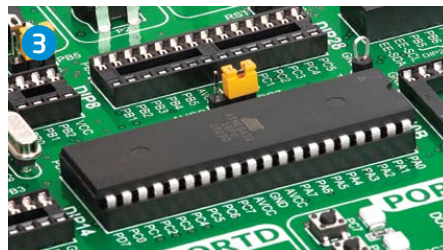

**Figure 4-4:** Properly placed microcontroller will have equally leveled pins.

all the pins match the socket as shown in **Figure 4-3**. Check again if everything is placed correctly and press the microcontroller until it is completely plugged into the socket as shown in **Figure 4-4**.

**IMPORTANT:** Only one microcontroller may be plugged into the development board at the same time.

## Using external clock



**Figure 4-5:** Position of the jumpers for DIP40x



**Figure 4-6:** Position of the jumpers for DIP28



**Figure 4-7:** Position of the jumpers for DIP20A



**Figure 4-8:** Position of the jumpers for DIP20B



**Figure 4-9:** Position of the jumpers for DIP14



**Figure 4-10:** Position of the jumpers for DIP8

AVR microcontrollers can use either built-in (internal) or quartz-crystal external clock for the purpose of providing clock signal source. The **EasyAVR™ v7** contains one quartz-crystal socket for all microcontroller sockets. **DIP40A** and **DIP40B** sockets are directly connected to quartz-crystal socket unlike **DIP28**, **DIP20A**, **DIP20B**, **DIP14** and **DIP8** sockets which are connected to it through the pin jumpers (J13-J17). The value of the

quartz-crystal depends on the maximum clock frequency allowed and your application as well. You can always replace the default 8MHz crystal with another one. If you want to use microcontrollers in **DIP40A** and **DIP40B** packages, it is necessary to place jumpers J13-J17 into the I/O position, **Figure 4-5**. The position of jumpers for **DIP28**, **DIP20A**, **DIP20B**, **DIP14** and **DIP8** sockets is shown in **Figure 4-6** to **Figure 4-10**.

# On-board programmer

## What is mikroProg™?

mikroProg™ is a fast USB 2.0 programmer. Smart engineering allows mikroProg™ to support about 65 AVR® microcontrollers from Atmel® in a single programmer! Outstanding performance and easy operation are among its top features.

## How do I start?

In order to start using mikroProg™ and program your microcontroller, you just have to follow two simple steps:

### 1. Install the necessary software

- Install USB drivers
- Install AVRFlash software

### 2. Power up the board, and you are ready to go.

- Plug in the programmer USB cable
- LINK LED should light up.

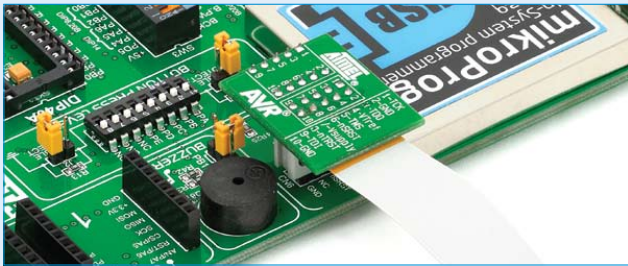

## Programming with JTAGICE mkII programmer

EasyAVR™ v7 is equipped with JTAG connector compatible with Atmel® AVR® JTAGICE mkII external programmer. You can use either the on-board mikroProg™ programmer or external programmer at the time. Place your programmer cable onto connector **CN6**, as shown in image.

## Why so many LEDs?

Three LEDs indicate specific programmer operation. **Link** LED lights up when USB link is established with your PC, **Active** LED lights up when the programmer is active. **Data** is on when data is being transferred between the programmer and PC software (compiler or AVRFlash).

## RESET or I/O?

Reset selection jumpers **J6**, **J7**, **J8**, **J9**, and **J10** are used to set PC6, PA2, PB7, PB3 or PB5 pin either as RST or I/O pin, respectively. Each of the pins belongs to different socket. For example, if you want to use PC6 pin (DIP28 socket) as I/O pin place jumper into the PC6 position. Other jumpers must be in RST position. For DIP40A and DIP40B sockets, all the reset selection jumpers must be in RST position.

**NOTE:** Before using the programmer, make sure that reset selection jumpers J6, J7, J8, J9, and J10 are placed into the mRST position for all sockets.



# Installing programmer drivers

On-board mikroProg™ requires drivers in order to work. Drivers are located on the **Product DVD** that you received with the EasyAVR™ v7 package:



DVD://download/eng/software/  
development-tools/avr/avrprog2/  
avrprog2\_drivers\_v200.zip

When you locate the drivers, please extract files from the ZIP archive. Folder with extracted files contains sub folders with drivers for different operating systems. Depending on which operating system you use, choose adequate folder and open it.

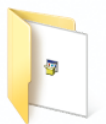

Windows 7 32 bit,  
Vista 32bit, Win  
2008 32 bit



Windows 7 64 bit,  
Vista 64bit, Win  
2008 64 bit



Win 2000, XP,  
2003 32-bit



Win 98



Win XP, 2003  
64-bit

In the opened folder you should be able to locate the driver setup file. Double click on setup file to begin installation of the programmer drivers.

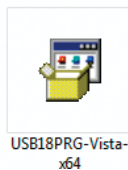

USB18PRG-Vista-  
x64

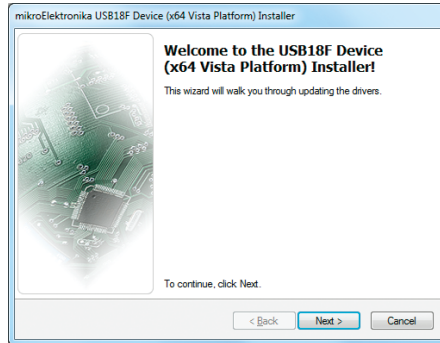

## Step 1 - Start Installation

Welcome screen of the installation. Just click on **Next** button to proceed.

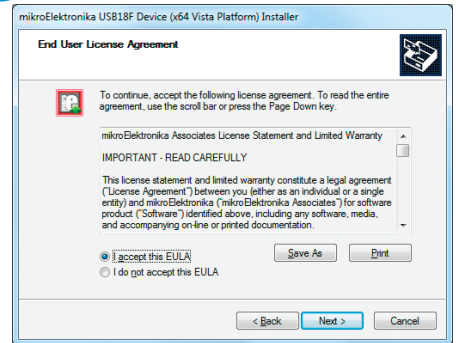

## Step 2 - Accept EULA

Carefully read **End User License Agreement**. If you agree with it, click **Next** to proceed.

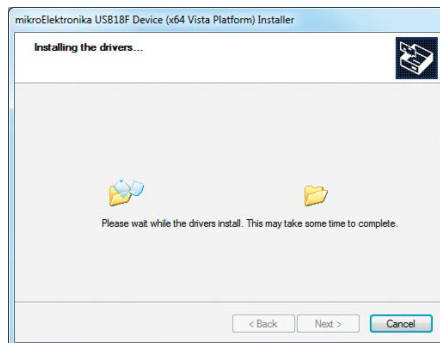

## Step 3 - Installing drivers

Drivers are installed automatically in a matter of seconds.

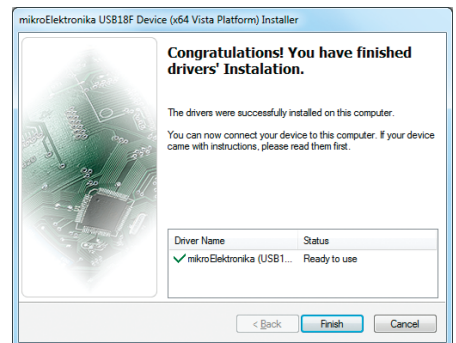

## Step 4 - Finish installation

You will be informed if the drivers are installed correctly. Click on **Finish** button to end installation process.

# Programming software

## AVRFlash software

On-board **mikroProg™** programmer requires special programming software called **AVRFlash**. This software is used for programming AVR® microcontrollers from Atmel®. Software has intuitive interface and **SingleClick™** programming technology. To begin, first locate the installation archive on the Product DVD:



DVD://download/eng/software/development-tools/avr/avr-prog2/avrprog2\_programmer\_v214.zip

After downloading, extract the package and double click the executable setup file, to start installation.

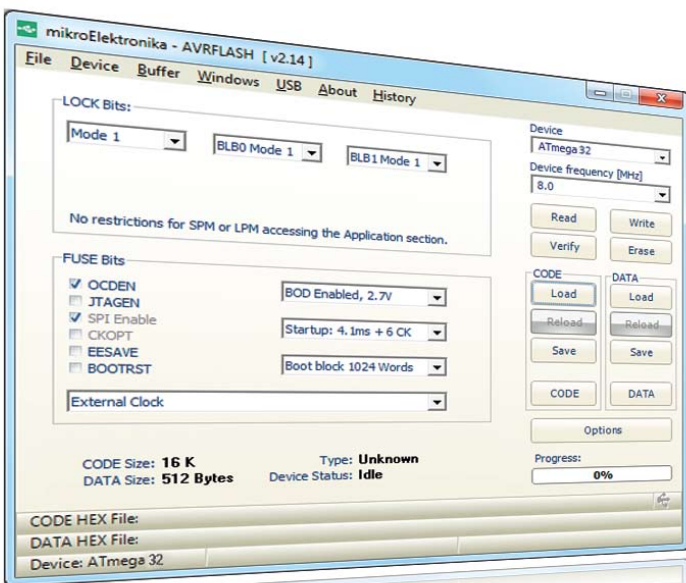

EasyAVR<sup>v7</sup>



## Installation wizard - 6 simple steps



Step 1 - Start Installation

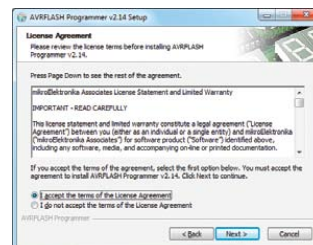

Step 2 - Accept EULA and continue

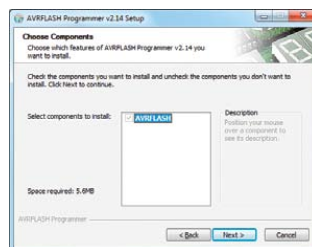

Step 3 - Click Next button

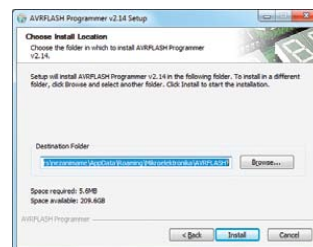

Step 4 - Choose destination folder

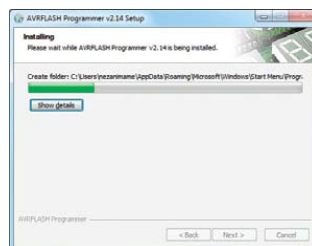

Step 5 - Installation in progress

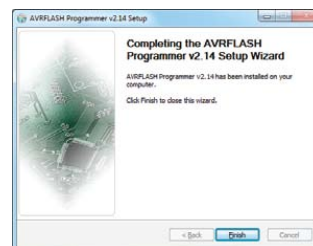

Step 6 - Finish Installation

# UART via RS-232



## Enabling RS-232

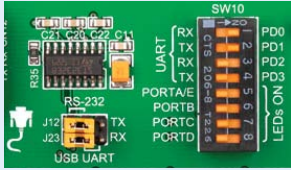

In order to enable RS-232 communication, you must set **J23** and **J12** jumpers in the **RS-232** position, and enable desired **RX** and **TX** lines via **SW10** DIP switch. For example, if you want to enable RS-232 connection on UART module of the default **ATmega32** chip, you should enable **SW10.1** (RD0) and **SW10.2** (RD1) lines.

The **UART** (universal asynchronous receiver/transmitter) is one of the most common ways of exchanging data between the MCU and peripheral components. It is a serial protocol with separate transmit and receive lines, and can be used for full-duplex communication. Both sides must be initialized with the same baud rate, otherwise the data will not be received correctly.

**RS-232 serial communication** is performed through a 9-pin SUB-D connector and the microcontroller UART module. In order to enable this communication, it is necessary to establish a connection between **RX** and **TX** lines on SUB-D connector and the same pins on the target microcontroller using DIP switches. Since RS-232 communication voltage levels are different than microcontroller logic levels, it is necessary to use a RS-232 Transceiver circuit, such as **MAX3232** as shown on **Figure 6-1**.

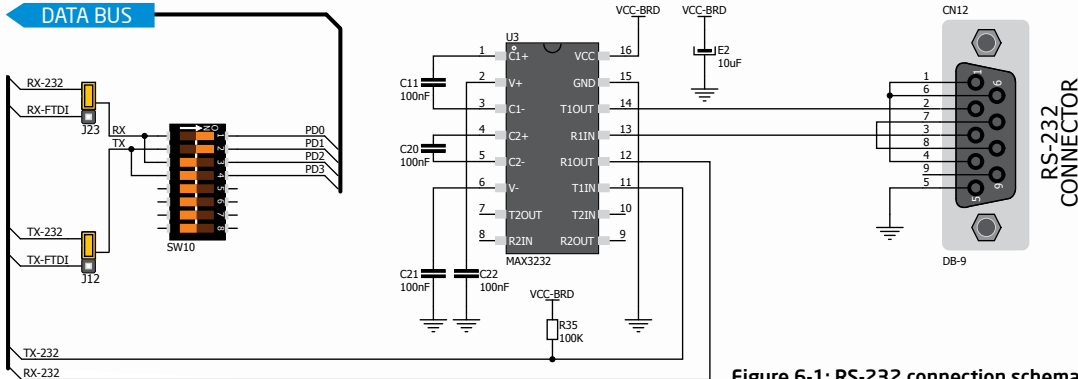
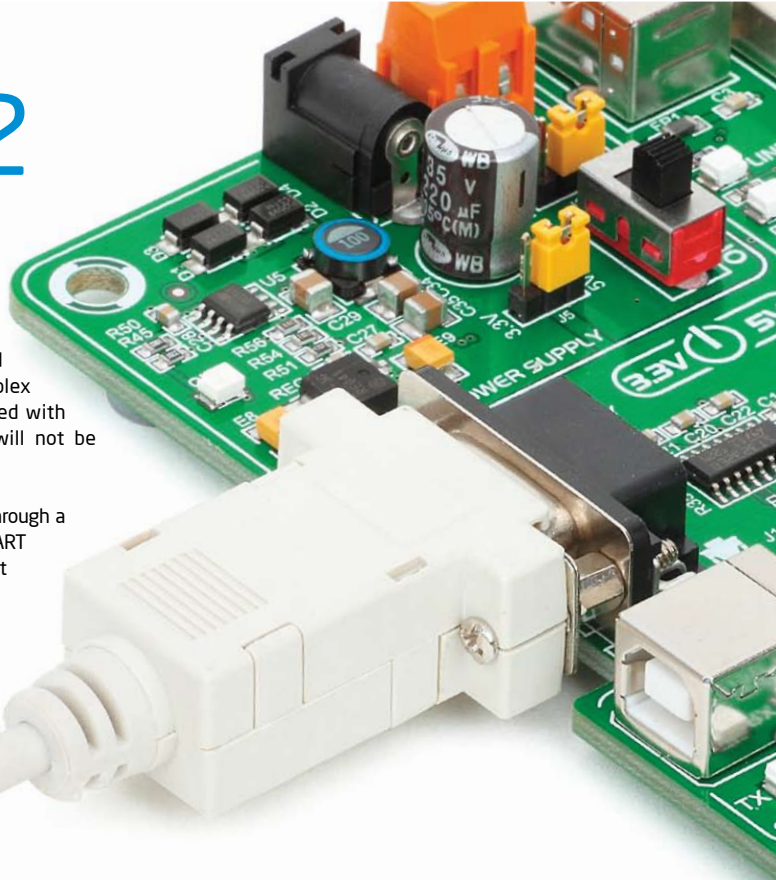
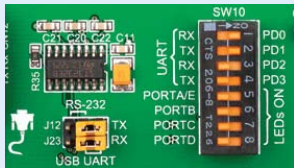

Figure 6-1: RS-232 connection schematic

# UART via USB



## Enabling USB-UART



In order to enable USB-UART communication, you must set **J23** and **J12** jumpers in the **USB-UART** position, and enable desired **RX** and **TX** lines via **SW10** DIP switch. For example, if you want to enable USB-UART connection on UART module of the default **ATmega32** chip, you should enable **SW10.1** (RD0) and **SW10.2** (RD1) lines.

Modern PC computers, laptops and notebooks are no longer equipped with RS-232 connectors and UART controllers. They are nowadays replaced with USB connectors and USB controllers. Still, certain technology enables UART communication to be done via USB connection. **FT232RL** from FTDI® convert UART signals to the appropriate USB standard. In order to use USB-UART module on EasyAVR™ v7, you must first install FTDI drivers on your computer. Drivers can be found on **Product DVD**:



[DVD://download/eng/software/development-tools/universal/ftdi/vcp\\_drivers.zip](DVD://download/eng/software/development-tools/universal/ftdi/vcp_drivers.zip)

USB-UART communication is being done through a FT232RL controller, USB connector (**CN4**), and microcontroller UART module. To establish this connection, you must put **J23** and **J12** jumpers in the **USB-UART** position, and connect **RX** and **TX** lines to the appropriate pins of the microcontroller. This connection is done using DIP switch **SW10**.

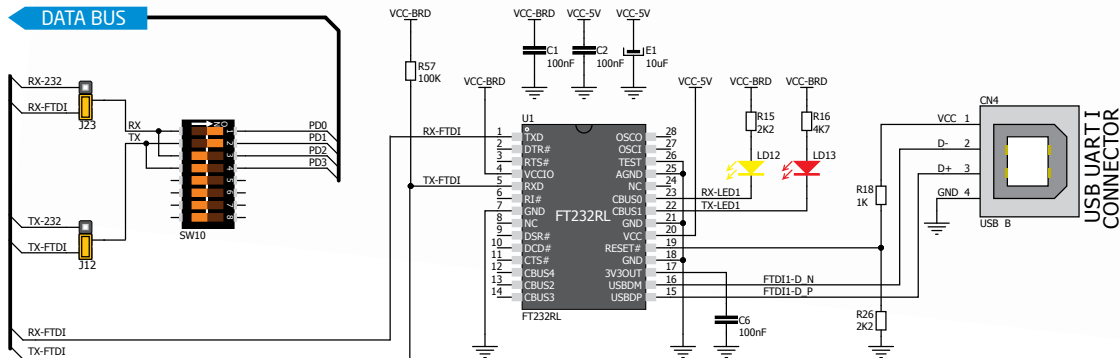
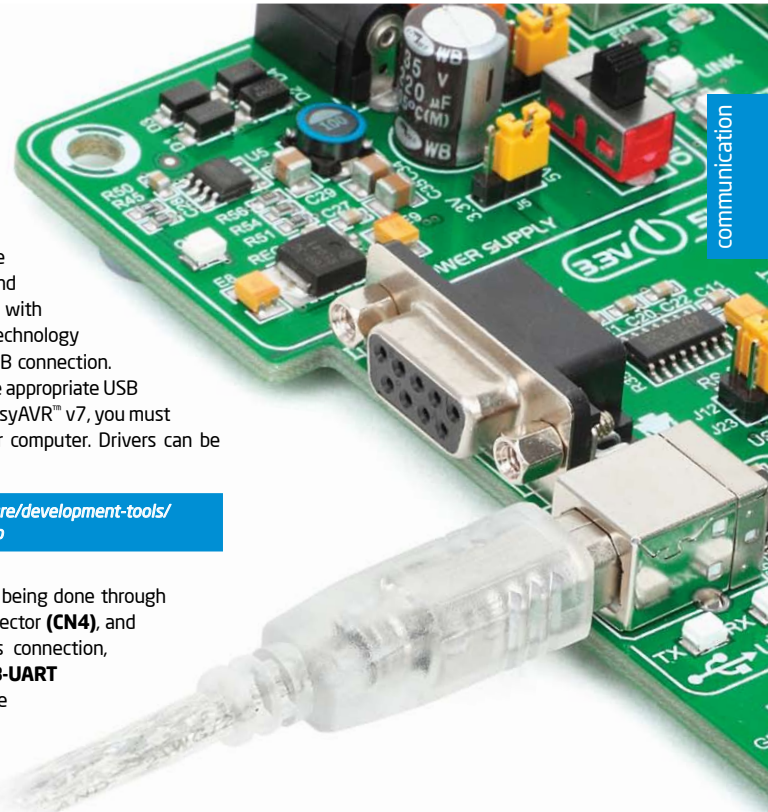
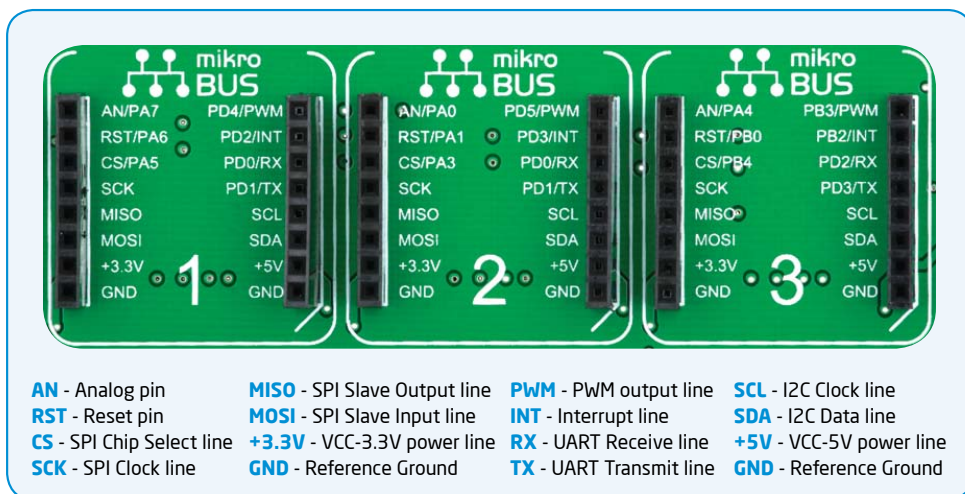

Figure 7-1: USB-UART connection schematic

# mikroBUS™ sockets

Easier connectivity and simple configuration are imperative in modern electronic devices. Success of the USB standard comes from its simplicity of usage and high and reliable data transfer rates. As we in mikroElektronika see it, Plug-and-Play devices with minimum settings are the future in embedded world too. This is why our engineers have come up with a simple, but brilliant pinout with lines that most of today's accessory boards require, which almost completely eliminates the need of additional hardware settings. We called this new standard the **mikroBUS™**. EasyAVR™ v7 is the first development board in the world to support mikroBUS™ with three on-board sockets. As you can see, there are no additional DIP switches, or jumper selections. Everything is already routed to the most appropriate pins of the microcontroller sockets.



## mikroBUS™ host connector

Each mikroBUS™ host connector consists of two 1x8 female headers containing pins that are most likely to be used in the target accessory board. There are three groups of communication pins: **SPI**, **UART** and **I<sup>2</sup>C** communication. There are also single pins for **PWM**, **Interrupt**, **Analog input**, **Reset** and **Chip Select**. Pinout contains two power groups: **+5V** and **GND** on one header and **+3.3V** and **GND** on the other 1x8 header.

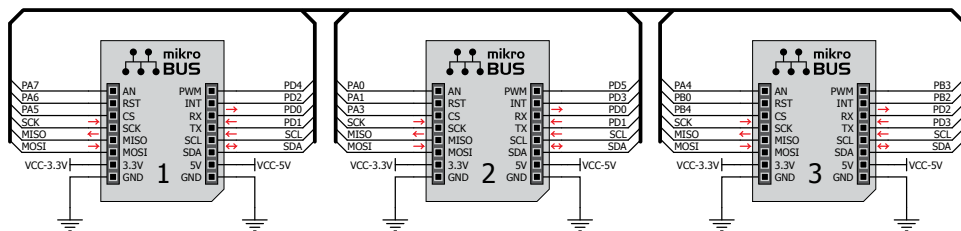

## SPI and I<sup>2</sup>C selection

Various microcontroller sockets have different pins for SPI and I<sup>2</sup>C interface. In order to connect the SPI and I<sup>2</sup>C pins of the mikroBUS™ with the desired socket, you have to change appropriate **SW3**, **SW5** or **SW6** DIP switches to ON position, **Figure 8-1**.

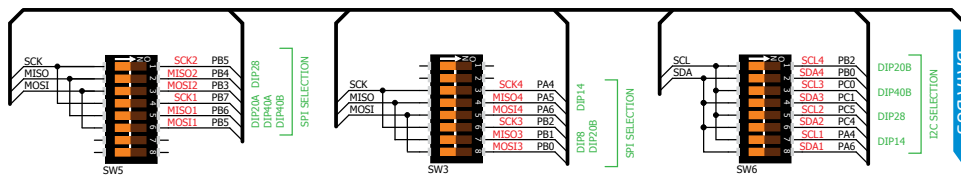

Figure 8-1: mikroBUS™ socket with DIP switches schematic





WiFi PLUS click™



GSM2 click™



GPS2 click™

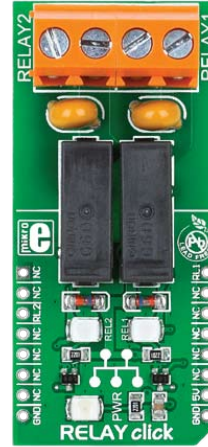

RELAY click™



THERMO click™

# Click Boards™ are plug-n-play!

mikroElektronika portfolio of over 200 accessory boards is now enriched by an additional set of mikroBUS™ compatible **Click Boards™**. Almost each month several new Click boards™ are released. It is our intention to provide the community with as much of these boards as possible, so you will be able to expand your EasyAVR™ v7 with additional functionality with literally zero

hardware configuration. Just plug and play. Visit the Click boards™ webpage for the complete list of available boards:

<http://www.mikroe.com/click/>

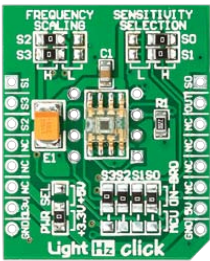

Light Hz click™



microSD click™



DAC click™



DIGIPOT click™



IR click™

EasyAVR™<sup>v7</sup>

# Input/Output Group

One of the most distinctive features of EasyAVR™ v7 are its Input/Output PORT groups. They add so much to the connectivity potential of the board.

## Everything is grouped together

PORT **headers**, PORT **buttons** and PORT **LEDs** are next to each other, and grouped together. It makes development easier, and the entire EasyAVR™ v7 cleaner and well organized. We have also provided an **additional PORT headers** on the left side of the board, so you can access any pin you want from both sides of the board.

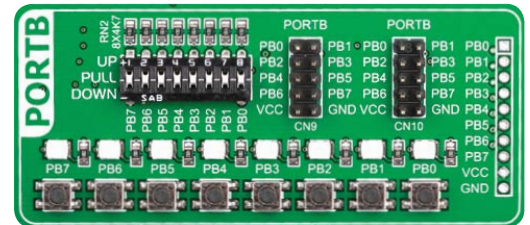

Figure 9-1: I/O group contains PORT headers, tri-state pull up/down DIP switch, buttons and LEDs all in one place

## Tri-state pull-up/down DIP switches

Tri-state DIP switches, like **SW1** on **Figure 9-2**, are used to enable 4K7 pull-up or pull-down resistor on any desired port pin. Each of these switches has three states:

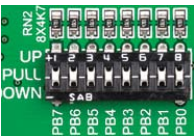

Figure 9-2: Tri-state DIP switch on PORTB

1. **middle position** disables both pull-up and pull-down feature from the PORT pin
2. **up position** connects the resistor in pull-up state to the selected pin
3. **down position** connects the resistor in pull-down state to the selected PORT pin.

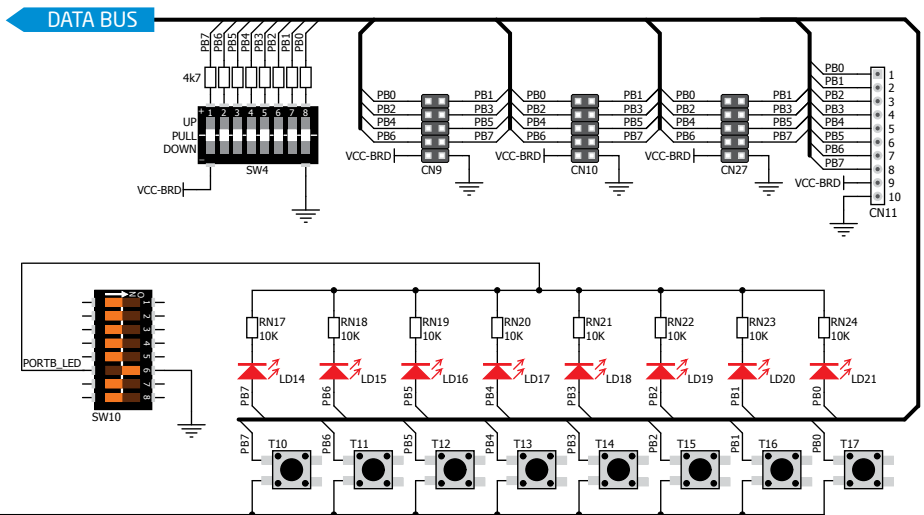
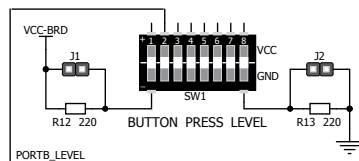
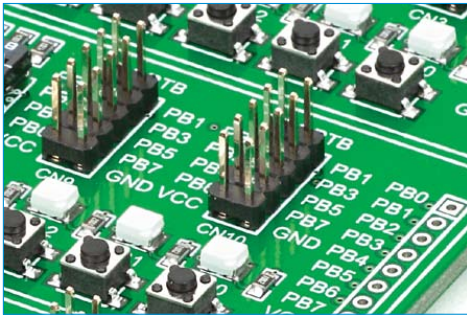
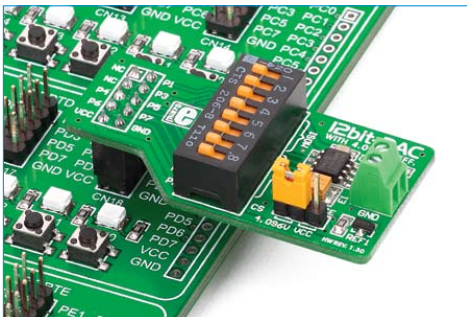

Figure 9-3: Schematic of the single I/O group connected to microcontroller PORTB



# Headers

With enhanced connectivity as one of the key features of EasyAVR v7, we have provided **three connection headers for each PORT**. I/O PORT group contains two male IDC10 headers (like **CN9** and **CN10** on **Figure 9-3**). These headers are all compatible with over 70 mikroElektronika accessory boards, and enable simple connection. There is **one more IDC10 header** available on the left side of the board, next to the section with displays. I/O PORT group also contains 1x10 connection pad (like **CN11** on **Figure 9-3**) which can be used for connecting mikroElektronika PROTO boards, or custom user boards.



**Figure 9-4:** IDC10 male headers enable easy connection with mikroElektronika accessory boards

EasyAVR<sup>v7</sup>

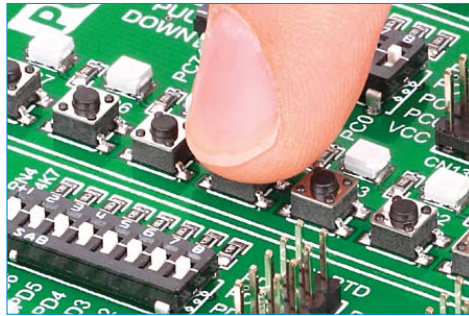

# Buttons



**Figure 9-5:** Button press level DIP switch (tri-state)

is available for selecting which logic state will be applied to corresponding MCU pin when button is pressed, for each I/O port separately. If you, for example, place **SW1.2** in **VCC** position, then pressing any of push buttons in PORTB I/O group will apply logic one to the appropriate microcontroller pin. The same goes for **GND**. If DIP switch is in the middle position neither of two logic states will be applied to the appropriate microcontroller pin. You can disable pin protection 220ohm resistors by placing jumpers **J1** and **J2**, which will connect your push buttons directly to VCC or GND. Be aware that doing so you may accidentally damage MCU in case of wrong usage.

## Reset Button

In the far upper right section of the board, there is a **RESET button**, which can be used to manually reset the microcontroller.



The logic state of all microcontroller digital inputs may be changed using **push buttons**. Tri-state DIP switch **SW1**

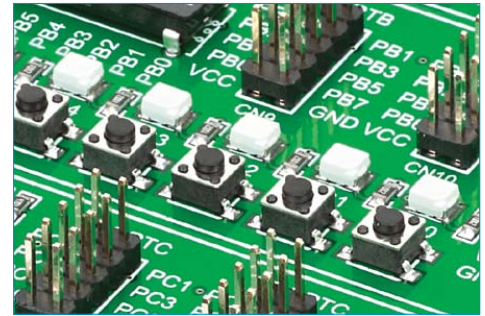

# LEDs

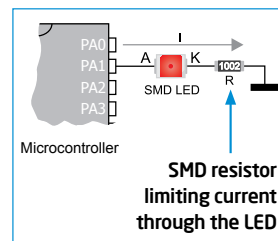

**LED (Light-Emitting Diode)** is a highly efficient electronic light source. When connecting LEDs, it is necessary to place a current limiting resistor in series so that LEDs are provided with the

current value specified by the manufacturer. The current varies from 0.2mA to 20mA, depending on the type of the LED and the manufacturer. The EasyAVR<sup>™</sup> v7 board uses low-current LEDs with typical current consumption of 0.2mA or 0.3mA, depending of VCC voltage selection. Board contains 35 LEDs which can be used for visual indication of the logic state on PORT pins. An active LED indicates that a logic high (1) is present on the pin. In order to enable PORT LEDs, it is necessary to enable the corresponding DIP switches on **SW10** (**Figure 9-6**).

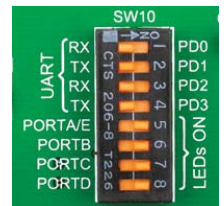

**Figure 9-6:** SW10.5 through SW10.8 switches are used to enable PORT LEDs

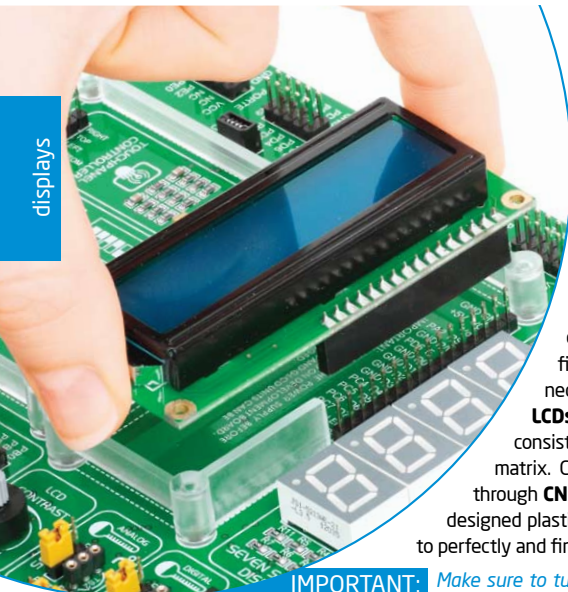

# LCD 2x16 characters

**Liquid Crystal Displays** or **LCDs** are cheap and popular way of representing information to the end user of some electronic device. Character LCDs can be used to represent standard and custom characters in the predefined number of fields. EasyAVR™ v7 provides the connector and the necessary interface for supporting **2x16 character LCDs** in 4-bit mode. This type of display has two rows consisted of 16 character fields. Each field is a 7x5 pixel matrix. Communication with the display module is done through **CN8** display connector. Board is fitted with uniquely designed plastic display distancer, which allows the LCD module to perfectly and firmly fit into place.

**IMPORTANT:** Make sure to turn off the power supply before placing LCD onto the board. Otherwise your display can be permanently damaged.



Figure 10-1: On-board LCD 2x16 display connector

## Connector pinout explained

**GND and VCC** - Display power supply lines

**Vo** - LCD contrast level from potentiometer P2

**RS** - Register Select Signal line

**E** - Display Enable line

**R/W** - Determines whether display is in Read or Write mode. It's always connected to GND, leaving the display in Write mode all the time.

**D0-D3** - Display is supported in 4-bit data mode, so lower half of the data byte interface is connected to GND.

**D4-D7** - Upper half of the data byte

**LED+** - Connection with the back-light LED anode

**LED-** - Connection with the back-light LED cathode

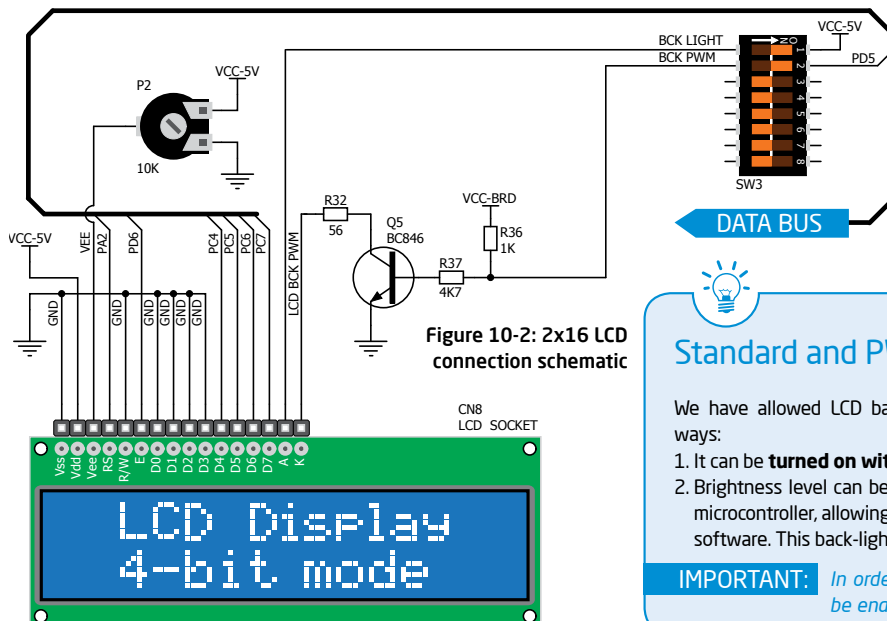

Figure 10-2: 2x16 LCD connection schematic

## Standard and PWM-driven back-light

We have allowed LCD back-light to be enabled in two different ways:

1. It can be **turned on with full brightness** using **SW3.1** switch.
2. Brightness level can be determined **with PWM signal** from the microcontroller, allowing you to write custom back-light controlling software. This back-light mode is enabled with **SW3.2** switch.

**IMPORTANT:** In order to use PWM back-light both **SW3.1** and **SW3.2** switches must be enabled at the same time.

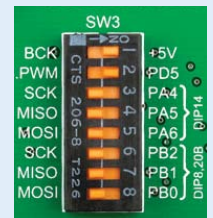

# GLCD 128x64

**Graphical Liquid Crystal Displays**, or **GLCDs** are used to display monochromatic graphical content, such as text, images, human-machine interfaces and other content. EasyAVR™ v7 provides the connector and necessary interface for supporting GLCD with resolution of 128x64 pixels, driven by the KS108 or compatible display controller. Communication with the display module is done through **CN16** display connector. Board is fitted with uniquely designed plastic display distancer, which allows the GLCD module to perfectly and firmly fit into place.

Display connector is routed to PB0, PB1, PA2, PA3, PD6, PD7 (control lines) and PORTC (data lines) of the microcontroller sockets. Since the same ports are used by 2x16 character LCD display, you cannot use both displays simultaneously. You can control the display contrast using dedicated potentiometer **P4**. Full brightness display back light can be enabled with **SW3.1** switch, and PWM-driven back light with **SW3.2** switch.

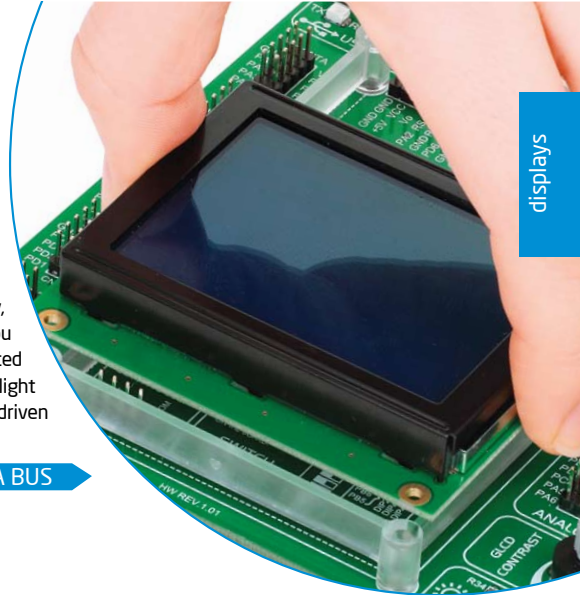

displays

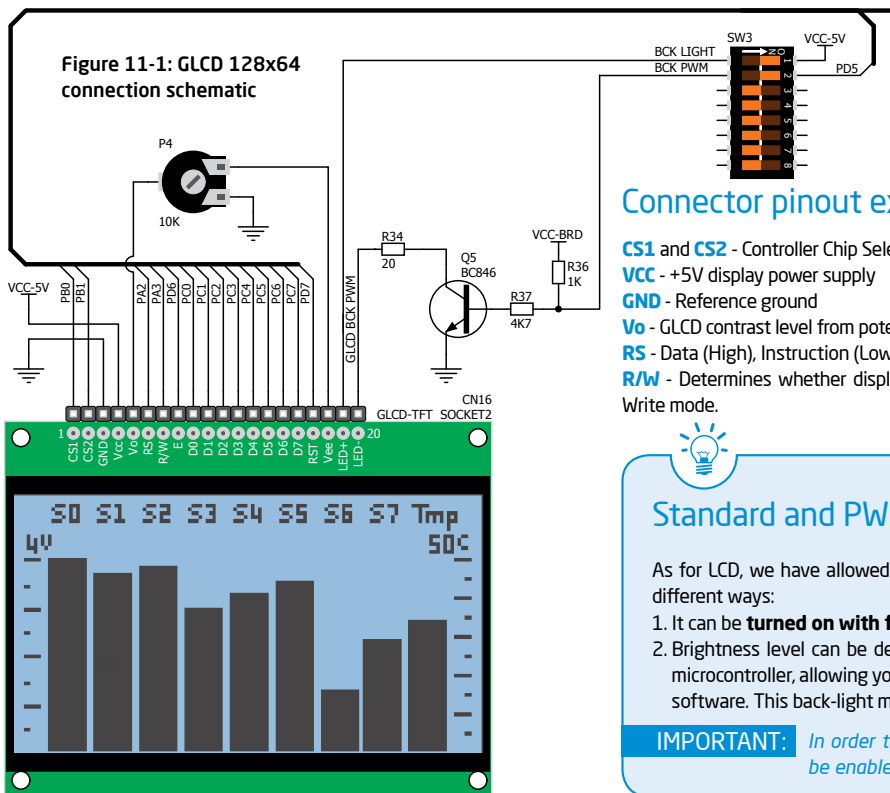

DATA BUS

Figure 11-1: GLCD 128x64 connection schematic

## Connector pinout explained

- CS1** and **CS2** - Controller Chip Select lines
- VCC** - +5V display power supply
- GND** - Reference ground
- Vo** - GLCD contrast level from potentiometer P4
- RS** - Data (High), Instruction (Low) selection line
- R/W** - Determines whether display is in Read or Write mode.

- E** - Display Enable line
- D0-D7** - Data lines
- RST** - Display reset line
- Vee** - Reference voltage for GLCD contrast potentiometer P3
- LED+** - Connection with the back-light LED anode
- LED-** - Connection with the back-light LED cathode



## Standard and PWM-driven back-light

As for LCD, we have allowed GLCD back-light to be enabled in two different ways:

1. It can be **turned on with full brightness** using **SW3.1** switch.
2. Brightness level can be determined **with PWM signal** from the microcontroller, allowing you to write custom back-light controlling software. This back-light mode is enabled with **SW3.2** switch.



**IMPORTANT:** In order to use PWM back-light both **SW3.1** and **SW3.2** switches must be enabled at the same time.

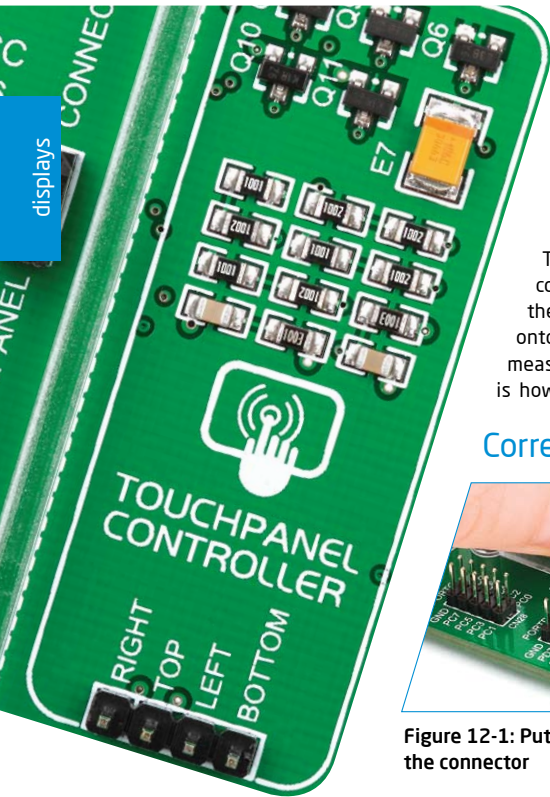

# Touch panel controller

Touch panel is a glass panel whose surface is covered with two layers of resistive material. When the screen is pressed, the outer layer is pushed onto the inner layer and appropriate controllers can measure that pressure and pinpoint its location. This is how touch panels can be used as an input devices.

EasyAVR™ v7 is equipped with touch panel controller and connector for **4-wire resistive touch panels**. It can very accurately register pressure at a specific point, representing the touch coordinates in the form of analog voltages, which can then be easily converted to X and Y values. Touch panel comes as a part of display.

## Correctly placing the touch panel cable into the connector

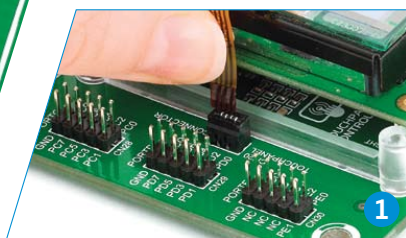

Figure 12-1: Put Touch panel flat cable in the connector

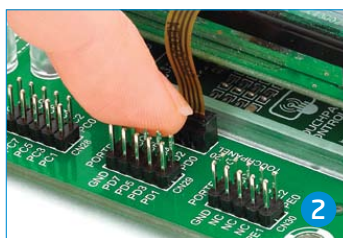

Figure 12-2: Use a tip of your finger to push it inside

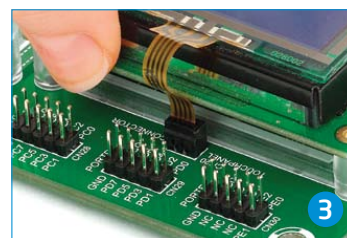

Figure 12-3: Now place GLCD with Touch panel into GLCD socket

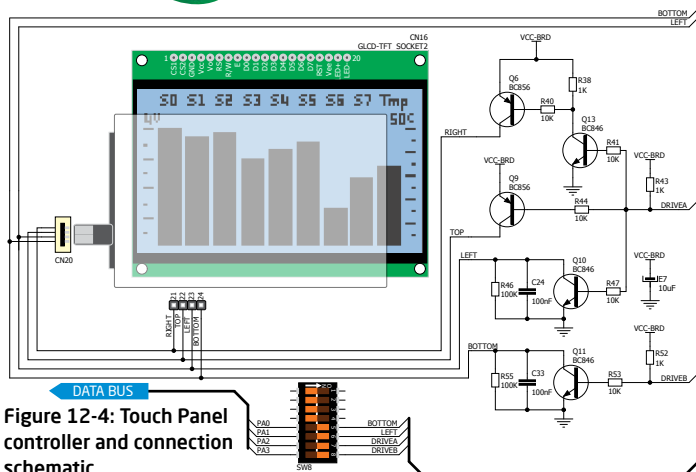

Figure 12-4: Touch Panel controller and connection schematic

## Enabling Touch panel

Touch panel is enabled using **SW8.5**, **SW8.6**, **SW8.7** and **SW8.8** switches. They connect **READ-X** and **READ-Y** lines of the touch panel with **PA0** and **PA1** analog inputs, and **DRIVEA** and **DRIVEB** with **PA2** and **PA3** digital outputs on microcontroller sockets. Make sure to disconnect other peripherals, LEDs and additional pull-up or pull-down resistors from the interface lines in order not to interfere with signal/data integrity.

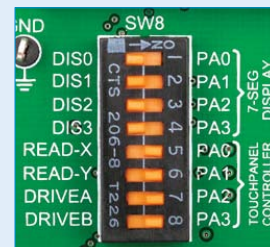

Figure 12-5: Turn on switches 5 through 8 on SW8 to enable Touch panel controller

# 4 digit 7-seg display

One seven segment digit consist of 7+1 LEDs which are arranged in a specific formation which can be used to represent digits from 0 to 9 and even some letters. One additional LED is used for marking the decimal dot, in case you want to write a decimal point in the desired segment. EasyAVR™ v7 contains four of these digits put together to form 4-digit 7-segment display. Driving such a display is done using **multiplexing techniques**. Data lines are shared between segments, and therefore the same segment LEDs in each digit are connected in parallel. Each digit has its **unique digit select line**,

which is used to enable the digit to which the data is currently being sent. By multiplexing data through all four segments fast enough, you create an illusion that all four segments are in operation simultaneously.

This is possible because human eye has a slower reaction time than the mention changes. This way you can represent numbers in decimal or hexadecimal form. Eight data lines that are common for all the digits are connected to PORTC, and digit select lines are connected to PA0-PA3 lines on the microcontroller sockets.

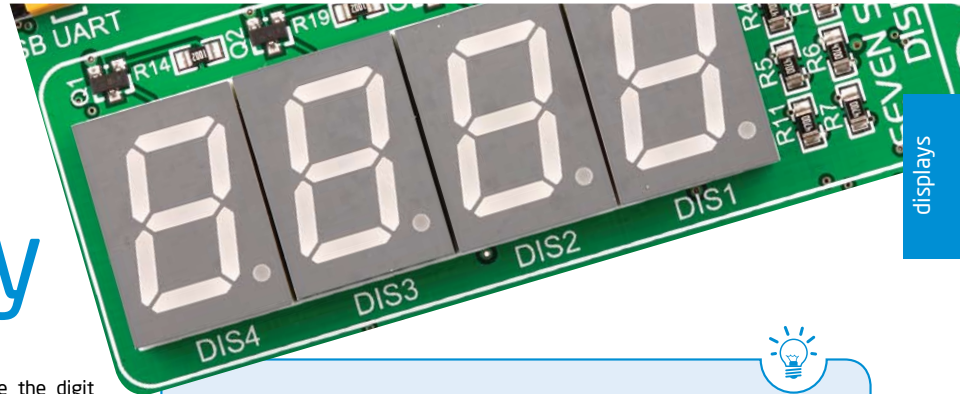

displays

## Enabling the display

To enable digit select lines for the 4-digit 7-segment display you have to turn on **SW8.1**, **SW8.2**, **SW8.3** and **SW8.4** switches. Digit select lines are connected to **PA0 - PA3** pins on the microcontroller sockets, while data lines are connected to **PC0 - PC7** pins. Make sure to disconnect other peripherals from the interface lines in order not to interfere with signal/data integrity.

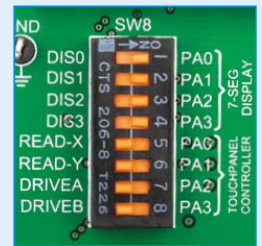

Figure 13-1: Turn on switches 1 through 4 on SW8 to enable 4-digit 7-seg display

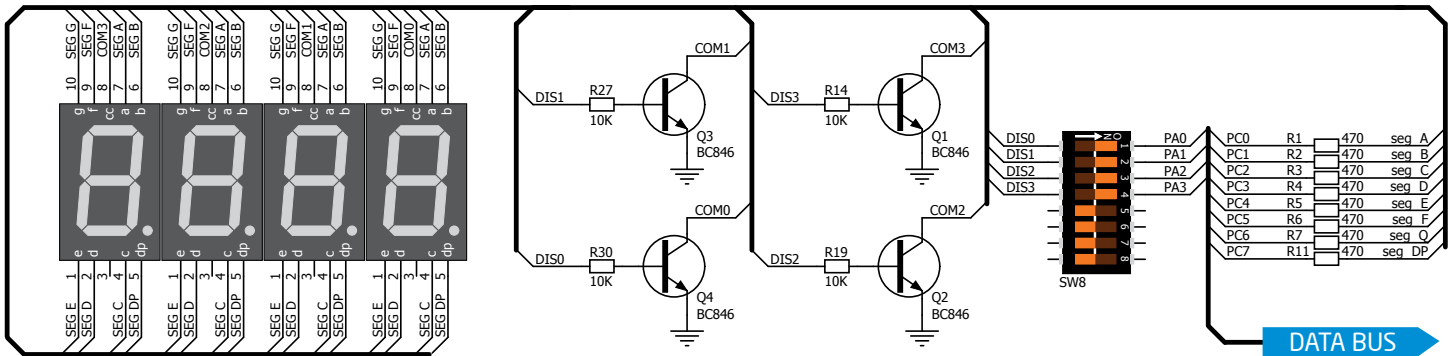

Figure 13-2: 4-digit 7-segment display schematic

# DS1820 - Digital Temperature Sensor

DS1820 is a digital temperature sensor that uses **1-wire® interface** for its operation. It is capable of measuring temperatures within the range of -55 to 128°C, and provides  $\pm 0.5^\circ\text{C}$  accuracy for temperatures within the range of -10 to 85°C. It requires 3V to 5.5V power supply for stable operation. It takes maximum

of 750ms for the DS1820 to calculate temperature with 9-bit resolution. **1-wire® serial communication** enables data to be transferred over a single communication line, while the process itself is under the control of the master microcontroller. The advantage of such communication is that only one microcontroller pin is used. Multiple

sensors can be connected on the same line. All slave devices by default have a unique ID code, which enables the master device to easily identify all devices sharing the same interface. EasyAVR™ v7 provides a separate socket (**TS1**) for the DS1820. Communication line with the microcontroller is connected via jumper **J18**.

## Enabling DS1820 Sensor

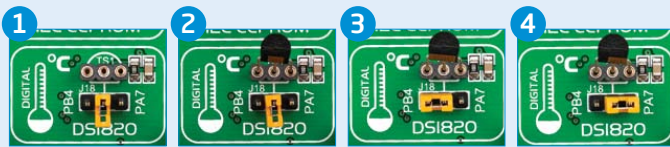

**Figure 14-1:**  
DS1820 not connected

**Figure 14-2:**  
DS1820 placed in socket

**Figure 14-3:**  
DS1820 connected to PB4 pin

**Figure 14-4:**  
DS1820 connected to PA7 pin

EasyAVR™ v7 enables you to establish 1-wire® communication between **DS1820** and the microcontroller via **PB4** or **PA7** microcontroller pins. The selection of either of those two lines is done using **J18** jumper. When placing the sensor in the socket make sure that half-circle on the board's silkscreen markings matches the rounded part of the DS1820 sensor. If you accidentally connect the sensor the other way, it may be permanently damaged. Make sure to disconnect other peripherals (except 1-wire), LEDs and additional pull-up or pull-down resistors from the interface lines in order not to interfere with signal/data integrity.

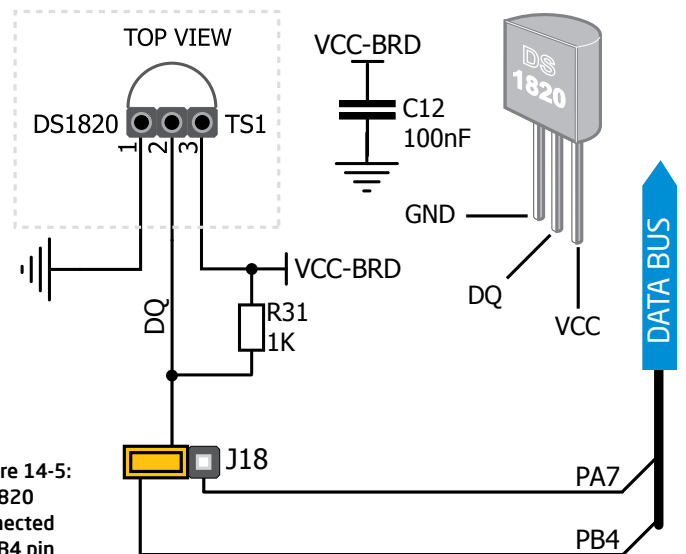

**Figure 14-5:**  
DS1820 connected to PB4 pin

EasyAVR™ v7



# LM35 - Analog Temperature Sensor

The **LM35** is a low-cost precision integrated-circuit temperature sensor, whose output voltage is linearly proportional to the Celsius (Centigrade) temperature. The LM35 thus has an advantage over linear temperature sensors calibrated in ° Kelvin, as the user is not required to subtract a large constant voltage from its output to

obtain convenient Centigrade scaling. It has a linear +10.0 mV/°C scale factor and less than 60 µA current drain. As it draws only 60 µA from its supply, it has very low self-heating, less than 0.1°C in still air. EasyAVR™ v7 enables you to get analog readings from the LM35 sensor in restricted temperature range from +2°C to +150°C. Board provides

a separate socket (**TS2**) for the LM35 sensor in TO-92 plastic packaging. Readings are done with microcontroller using single analog input line, which is selected with jumper **J19**. Jumper connects the sensor with either **PA7** or **PB4** microcontroller pins.

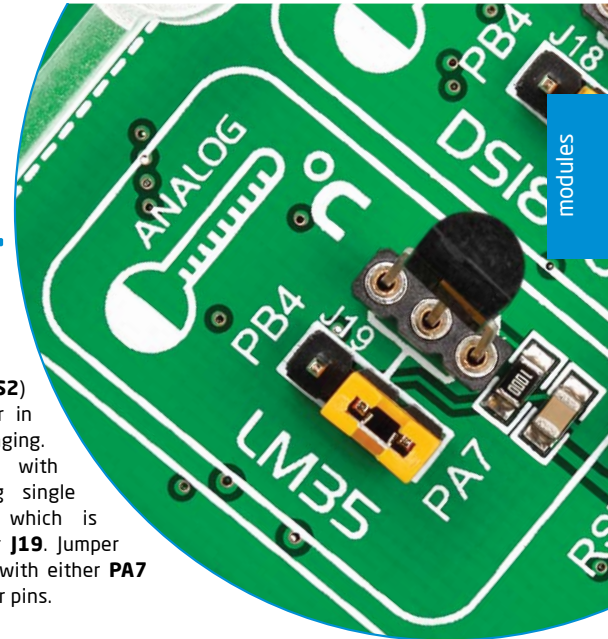

## Enabling LM35 Sensor

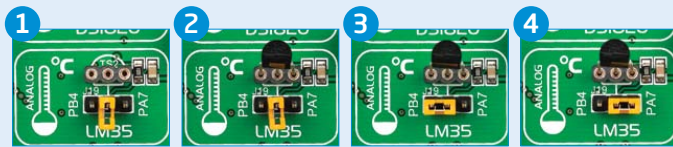

**Figure 15-1:** LM35 not connected

**Figure 15-2:** LM35 placed in socket

**Figure 15-3:** LM35 connected to PB4 pin

**Figure 15-4:** LM35 connected to PA7 pin

EasyAVR™ v7 enables you to get analog readings from the LM35 sensor using **PA7** or **PB4** microcontroller pins. The selection of either of those two lines is done using **J19** jumper. When placing the sensor in the socket make sure that half-circle on the board's silkscreen markings matches the rounded part of the LM35 sensor. If you accidentally connect the sensor the other way, it can be permanently damaged and you might need to replace it with another one. During the readings of the sensor, make sure that no other device uses the selected analog line, because it may interfere with the readings.

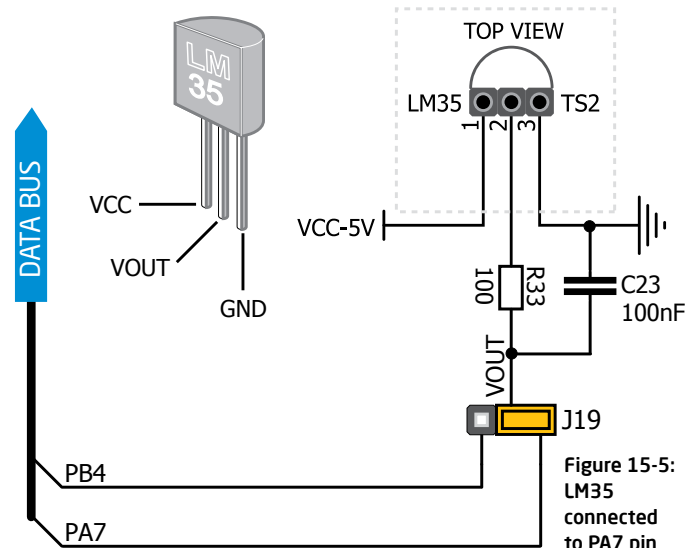

**Figure 15-5:** LM35 connected to PA7 pin

# ADC inputs

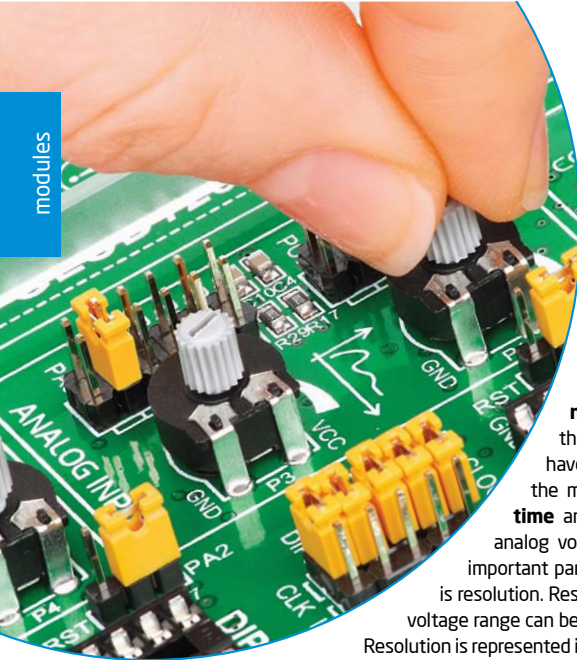

**Digital signals** have **two discrete states**, which are decoded as **high** and **low**, and interpreted as **logic 1** and **logic 0**. **Analog signals**, on the other hand, are **continuous**, and can have any value within defined range. **A/D converters** are specialized circuits which can convert analog signals (voltages) into a digital representation, usually in form of an **integer number**. The value of this number is **linearly dependent** on the input voltage value. Most microcontrollers nowadays internally have A/D converters connected to one or more input pins. Some of the most important parameters of A/D converters are **conversion time** and **resolution**. Conversion time determines how fast an analog voltage can be represented in form of a digital number. This is an important parameter if you need fast data acquisition. The other parameter is resolution. Resolution represents the number of discrete steps that supported voltage range can be divided into. It determines the sensitivity of the A/D converter.

Resolution is represented in maximum number of bits that resulting number occupies. Most AVR® microcontrollers have 10-bit resolution, meaning that maximum value of conversion can be represented with 10 bits, which converted to integer is  $2^{10}=1024$ . This means that supported voltage range, for example from 0-5V, can be divided into 1024 discrete steps of about 4.88mV. EasyAVR™ v7 provides an interface in form of two potentiometers for simulating analog input voltages that can be routed to any of the 12 supported analog input pins.

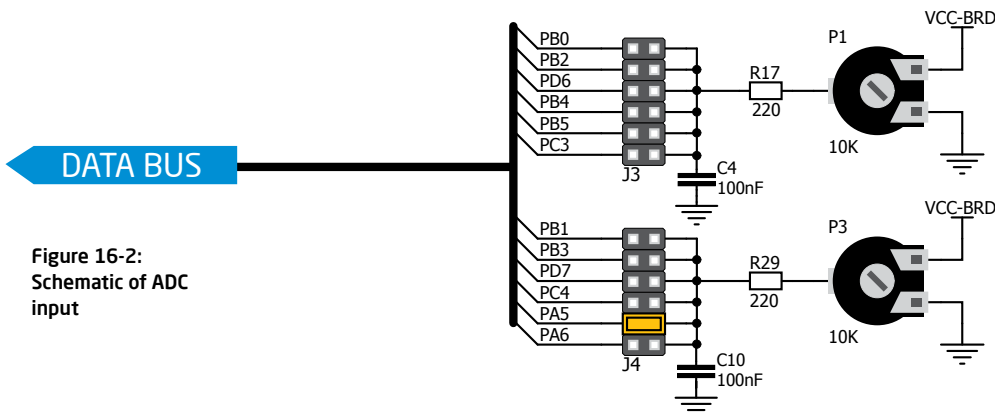

Figure 16-2:  
Schematic of ADC  
input



## Enabling ADC inputs

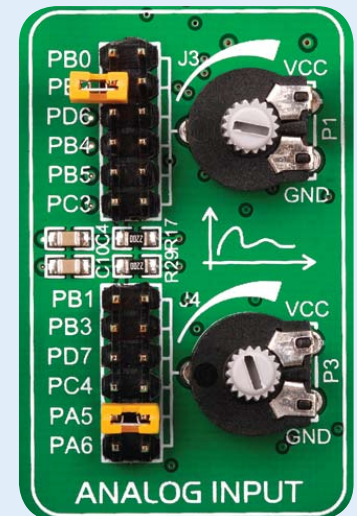

Figure 16-1: use J3 and J4 jumpers to connect analog input lines

In order to connect the output of the potentiometer **P1** to **PB0**, **PB2**, **PD6**, **PB4**, **PB5** or **PC3** analog microcontroller inputs, you have to place the jumper **J3** in the desired position. If you want to connect potentiometer **P3** to any of the **PB1**, **PB3**, **PD7**, **PC4**, **PA5** or **PA6** analog microcontroller inputs, place jumper **J4** in the desired position. By moving the potentiometer knob, you can create voltages in range from **GND** to **VCC-BRD**.

# I<sup>2</sup>C EEPROM



## Enabling I<sup>2</sup>C EEPROM

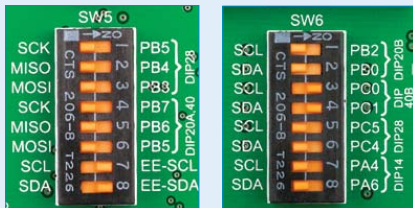

In order to connect I<sup>2</sup>C EEPROM to the microcontroller you must enable **SW5.7** and **SW5.8** as well as appropriate **SW6** switches depending on socket you want to use, as shown on **Figure 17-1**. **1kΩ** pull-up resistors necessary for I<sup>2</sup>C communication are already provided on **SDA** and **SCL** lines once switches are turned on. Prior to using EEPROM in your application, make sure to disconnect other peripherals, LEDs and additional pull-up or pull-down resistors from the interface lines in order not to interfere with signal/data integrity.

**EEPROM** is short for **Electrically Erasable Programmable Read Only Memory**. It is usually a secondary storage memory in devices containing data that is retained even if the device loses power supply. Because of the ability to alter single bytes of data, EEPROM devices are used to store personal preference and configuration data in a wide spectrum of consumer, automotive, telecommunication, medical, industrial, and PC applications.

EasyAVR™ v7 supports serial EEPROM which uses **I<sup>2</sup>C communication interface** and has **1024 bytes** of available memory. Board contains socket for serial EEPROMs in DIP8 packaging, so you can easily exchange it with different memory size EEPROM IC. EEPROM itself supports single byte or 16-byte (page) write and read operations. Data rate is 400 kHz for both 3.3V and 5V power supply.

## What is I<sup>2</sup>C?

I<sup>2</sup>C is a multi-master serial single-ended bus that is used to attach low-speed peripherals to computer or embedded systems. I<sup>2</sup>C uses only two open-drain lines, **Serial Data Line (SDA)** and **Serial Clock (SCL)**, pulled up with resistors. **SCL** line is driven by a master, while **SDA** is used as bidirectional line either by master or slave device. Up to 112 slave devices can be connected to the same bus. Each slave must have a unique address.

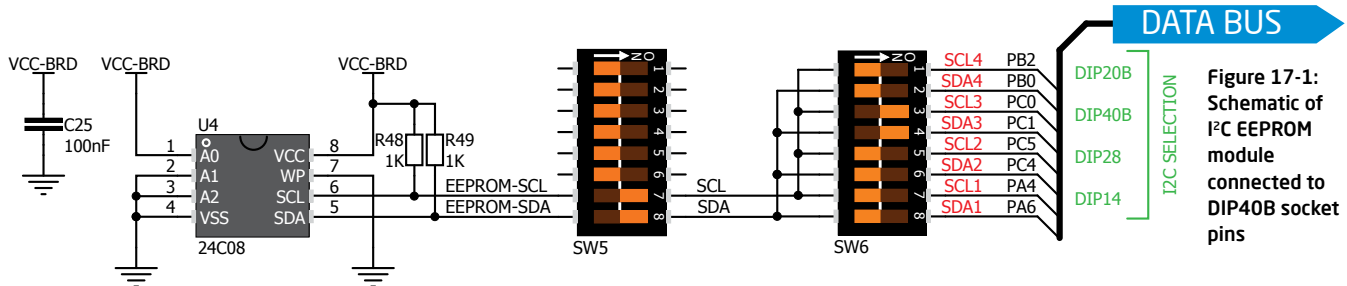
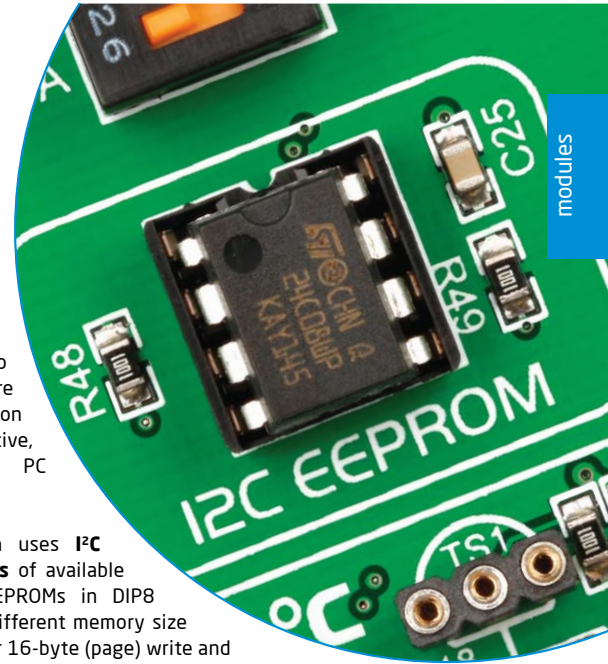

**Figure 17-1:** Schematic of I<sup>2</sup>C EEPROM module connected to DIP40B socket pins

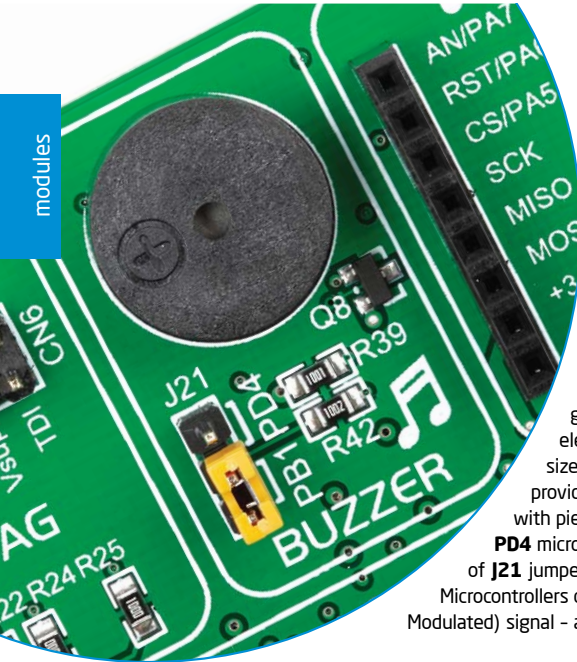

# Piezo Buzzer

**Piezo electricity** is the charge which accumulates in certain solid materials in response to mechanical pressure, but also providing the charge to the piezoelectric material causes it to physically deform. One of the most widely used applications of piezo electricity is the production of sound generators, called piezo buzzers. **Piezo buzzer** is an electric component that comes in different shapes and sizes, which can be used to create sound waves when provided with analog electrical signal. EasyAVR™ v7 comes with piezo buzzer which can be connected either to **PB1** or **PD4** microcontroller pins, which is determined by the position of **J21** jumper. Buzzer is driven by transistor **Q8** (Figure 18-1). Microcontrollers can create sound by generating a PWM (Pulse Width Modulated) signal - a **square wave** signal, which is nothing more than

a sequence of logic zeros and ones. Frequency of the square signal determines the pitch of the generated sound, and duty cycle of the signal can be used to increase or decrease the volume in the range from 0% to 100% of the duty cycle. You can generate PWM signal using hardware capture-compare module, which is usually available in most microcontrollers, or by writing a custom software which emulates the desired signal waveform.

## Supported sound frequencies

Piezo buzzer's resonant frequency (where you can expect it's best performance) is **3.8kHz**, but you can also use it to create sound in the range between **2kHz** and **4kHz**.

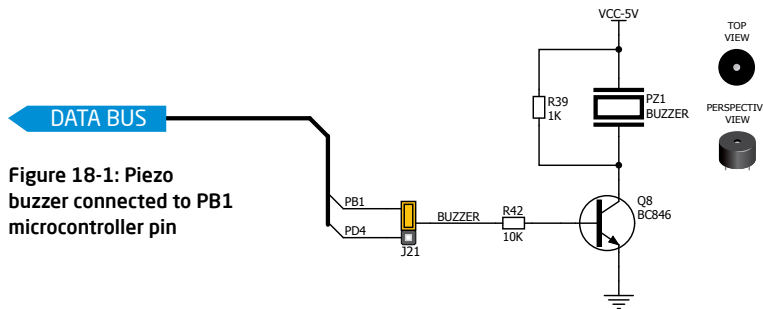

Figure 18-1: Piezo buzzer connected to PB1 microcontroller pin

Freq = 3kHz, Duty Cycle = 50%



Freq = 3kHz, Volume = 50%

Freq = 3kHz, Duty Cycle = 80%



Freq = 3kHz, Volume = 80%

Freq = 3kHz, Duty Cycle = 20%



Freq = 3kHz, Volume = 20%

## How to make it sing?

Buzzer starts "singing" when you provide PWM signal from the microcontroller to the buzzer driver. The pitch of the sound is determined by the frequency, and amplitude is determined by the duty cycle of the PWM signal.



## Enabling Piezo Buzzer

In order to use the on-board Piezo Buzzer in your application, you first have to connect the transistor driver of piezo buzzer to the appropriate microcontroller pin. This is done using jumper **J21**. You can place the jumper in two positions, thus connecting the buzzer driver to either **PB1** or **PD4** microcontroller pin.



Figure 18-2: Use jumper J21 to connect Piezo buzzer on PB1 or PD4 pin



# Additional GNDs

EasyAVR™ v7 contains three **GND pins** located in three different sections of the board, which allow you to easily connect oscilloscope GND reference when you monitor signals on microcontroller pins, or signals of on-board modules.

- 1 GND is located between SW10 and SW8 DIP switches.
- 2 GND is located between DIP20A and DIP20B sockets.
- 3 GND is located between DIP28 and DIP40B sockets.



Figure 19-1:  
3 oscilloscope  
GND pins are  
conveniently  
positioned so  
each part of the  
board can be  
reached with  
an oscilloscope  
probe



1

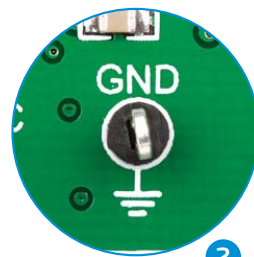

2

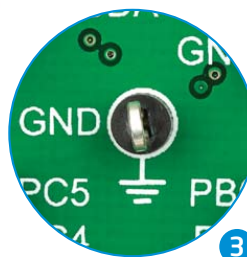

3

# What's Next?

You have now completed the journey through each and every feature of **EasyAVR™ v7 board**. You got to know it's modules, organization, supported microcontrollers, programmer. Now you are ready to start using your new board. We are suggesting several steps which are probably the best way to begin. We invite you to join thousands of users of EasyAVR™ brand. You will find very useful projects and tutorials and can get help from a large ecosystem of users. Welcome!

## 1 Compiler

You still don't have an appropriate compiler? Locate **AVR compiler** that suits you best on the **Product DVD** provided with the package:

`DVD://download/eng/software/compilers/`

Choose between **mikroC™**, **mikroBasic™** and **mikroPascal™** and download fully functional demo version, so you can begin building your AVR applications.

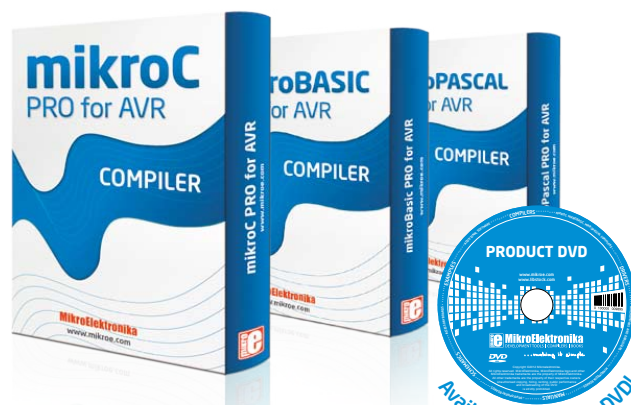

## 2 Projects

Once you have chosen your compiler, and since you already got the board, you are ready to start writing your first projects. We have equipped our compilers with dozens of examples that demonstrate the use of each and every feature of the EasyAVR™ V7 board, and all of our accessory boards as well. This makes an excellent starting point for your future projects. Just load the example, read well commented code, and see how it works on hardware. Browse through the compiler **Examples** path to find the following folder:

`\Development Systems\`

## 3 Community

If you want to find answers to your questions on many interesting topics we invite you to visit our forum at <http://www.mikroe.com/forum> and browse through more than 150 thousand posts. You are likely to find just the right information for you. On the other hand, if you want to download free projects and libraries, or share your own code, please visit the **Libstock™ website**. With user profiles, you can get to know other programmers, and subscribe to receive notifications on their code.

<http://www.libstock.com/>

## 4 Support

We all know how important it is that we can rely on someone in moments when we are stuck with our projects, facing a deadline, or when we just want to ask a simple, basic question, that's pulling us back for a while. We do understand how important this is to people and therefore our Support Department is one of the pillars upon which our company is based. MikroElektronika offers **Free Tech Support** to the end of product lifetime, so if something goes wrong, we are ready and willing to help!

<http://www.mikroe.com/esupport/>

# DISCLAIMER

All the products owned by MikroElektronika are protected by copyright law and international copyright treaty. Therefore, this manual is to be treated as any other copyright material. No part of this manual, including product and software described herein, must be reproduced, stored in a retrieval system, translated or transmitted in any form or by any means, without the prior written permission of MikroElektronika. The manual PDF edition can be printed for private or local use, but not for distribution. Any modification of this manual is prohibited.

MikroElektronika provides this manual 'as is' without warranty of any kind, either expressed or implied, including, but not limited to, the implied warranties or conditions of merchantability or fitness for a particular purpose.

MikroElektronika shall assume no responsibility or liability for any errors, omissions and inaccuracies that may appear in this manual. In no event shall MikroElektronika, its directors, officers, employees or distributors be liable for any indirect, specific, incidental or consequential damages (including damages for loss of business profits and business information, business interruption or any other pecuniary loss) arising out of the use of this manual or product, even if MikroElektronika has been advised of the possibility of such damages. MikroElektronika reserves the right to change information contained in this manual at any time without prior notice, if necessary.

## HIGH RISK ACTIVITIES

The products of MikroElektronika are not fault-tolerant nor designed, manufactured or intended for use or resale as on-line control equipment in hazardous environments requiring fail-safe performance, such as in the operation of nuclear facilities, aircraft navigation or communication systems, air traffic control, direct life support machines or weapons systems in which the failure of Software could lead directly to death, personal injury or severe physical or environmental damage ('High Risk Activities'). MikroElektronika and its suppliers specifically disclaim any expressed or implied warranty of fitness for High Risk Activities.

## TRADEMARKS

The MikroElektronika name and logo, the MikroElektronika logo, mikroC™, mikroBasic™, mikroPascal™, mikroProg™, EasyAVR™, READY™, mikroBus™, mikromedia™, MINI™ and Click boards™ are trademarks of MikroElektronika. All other trademarks mentioned herein are property of their respective companies.

All other product and corporate names appearing in this manual may or may not be registered trademarks or copyrights of their respective companies, and are only used for identification or explanation and to the owners' benefit, with no intent to infringe.

Copyright © MikroElektronika™, 2013, All Rights Reserved.



If you want to learn more about our products, please visit our website at [www.mikroe.com](http://www.mikroe.com)

If you are experiencing some problems with any of our products or just need additional information, please place your ticket at [www.mikroe.com/esupport](http://www.mikroe.com/esupport)

If you have any questions, comments or business proposals,  
do not hesitate to contact us at [office@mikroe.com](mailto:office@mikroe.com)

EasyAVR v7 User Manual  
ver. 1.01

