

MR-BusIO-RELAY™ BusIO Relay BOARD  
User Manual

# GRAVITECH.US



# *uResearch*

## GRAVITECH GROUP

Copyright © 2007 MicroResearch  
GRAVITECH GROUP WWW.GRAVITECH.US

# MR-BusIO-RELAY™ BusIO Relay BOARD User Manual

## Description

The MR-BusIO-RELAY is an experiment board for switching AC or DC output by using mechanical relay. The maximum controlling voltage is 250VAC at 5A or 24VDC at 10A. It is using PC817 Photo-coupler IC to isolate high current and low current. It is best for switching output load.

The board can be use with MR-BusIO-MAIN board or stand-alone. PCB size is 0.63" x 2.80"

## Operation:

The PC817 require at least 5mA to drive input photo-coupler LED. It can take up to 6V in reverse bias. For an output (between collector and emitter), it can drive up to 35V with 50mA continuous current.

The operation of this board starts when applying logic HIGH to an I/O pin. The indicator LED then illuminated. The output of PC817 is driving second BC547 transistor which drive to energize the coil of the relay. The diode across the coil is to protect back EMF.

User can connect DC or AC load through output 3-PIN terminal block. It connected directly from the relay: pin1 NO (Normally Open), pin2 COM (Common), and pin3 NC (Normally Close).

User can connect output AC of DC load up to 250VAC at 5A or 24VDC at 10A.

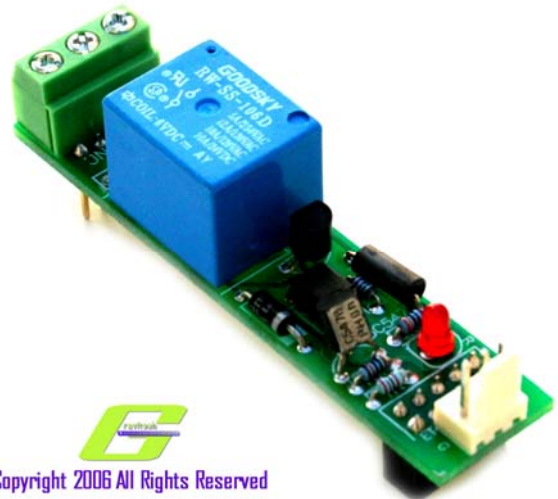

Copyright 2006 All Rights Reserved

## MR-BusIO-MAIN

The MR-BusIO-MAIN is available for purchase via our website. If you don't see the item you need, please contract our sales department at [sales@gravitech.us](mailto:sales@gravitech.us)

- **MR-BusIO-MAIN**

Experiment board which receives output signals from any microcontrollers. The signals then distribute to daughter boards for each experiment. It designed to connect directly with 10PIN MRconnect®. It is a quick and easy way to control up to 8 daughter boards.

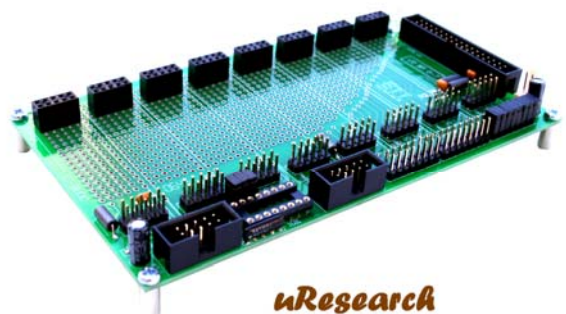

uResearch  
© 2007 Copyright. All Rights Reserved

**Copyright © 2007 MicroResearch**  
GRAVITECH GROUP WWW.GRAVITECH.US

# MR-BusIO-RELAY™ BusIO Relay BOARD User Manual

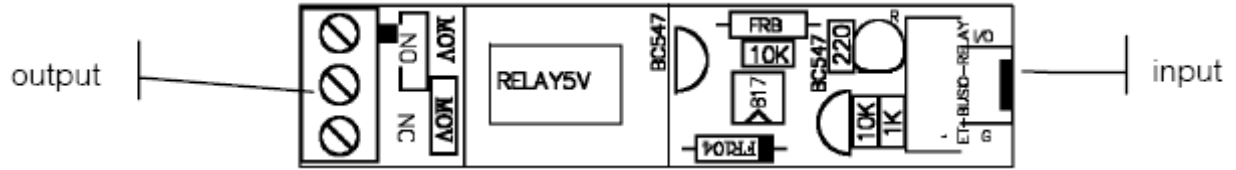

FIG 1: MR-BusIO-RELAY Board Layout

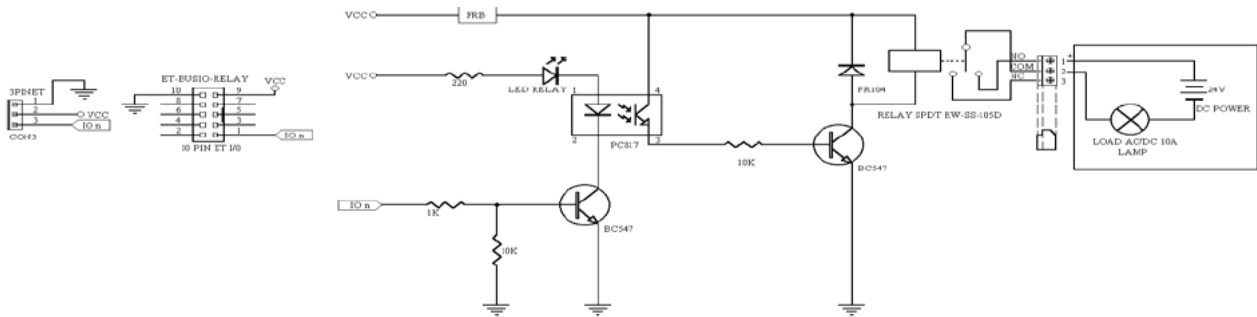

FIG 2: MR-BusIO-RELAY Schematic

**Copyright © 2007 MicroResearch**  
GRAVITECH GROUP      WWW.GRAVITECH.US

# MR-BusIO-RELAY™ BusIO Relay BOARD User Manual

## Notes

## Contact Us

We maintain a website where you can get information on our products, obtain literature and download support files. Visit us online at:

**[WWW.GRAVITECH.US](http://WWW.GRAVITECH.US)**

Use our online Forum or e-mail your technical support questions to [support@gravitech.us](mailto:support@gravitech.us). We try to respond to your questions the same day.

For sales questions or to place and order, direct your e-mails to [sales@gravitech.us](mailto:sales@gravitech.us). Refer to our website for product pricing, shipping rates, payment instructions, and for other info we need to complete your order.

**Disclaimer: MicroResearch reserves the right to modify its products or literature, or to discontinue any product at any time without prior notice. The customer is responsible for determining the suitability of any device for any application developed using MicroResearch components.**

**Copyright © 2007 MicroResearch**  
GRAVITECH GROUP      WWW.GRAVITECH.US