

RTC PROTO™

Manual

All Mikroelektronika's development systems feature a large number of peripheral modules expanding microcontroller's range of application and making the process of program testing easier. In addition to these modules, it is also possible to use numerous additional modules linked to the development system through the I/O port connectors. Some of these additional modules can operate as stand-alone devices without being connected to the microcontroller.

Additional Board

 **MikroElektronika**

SOFTWARE AND HARDWARE SOLUTIONS FOR EMBEDDED WORLD ...making it simple

RTC PROTO (Real time clock PROTO)

The *RTC PROTO* enables the microcontroller to keep the real time and date, providing the alarm function. It is used to generate an interrupt. Due to battery cell the *RTC PROTO* enables the microcontroller to keep the real time when the power supply is off. The *RTC PROTO* is linked to the development system by connecting 1x5 male connector provided on the additional board to the proto board provided on the development system's ports. The *RTC PROTO* communicates to the microcontroller by using the serial I²C interface. The *RTC PROTO* is placed on the development system's port that is connected to the built-in I²C microcontroller module.



Figure 1: RTC PROTO

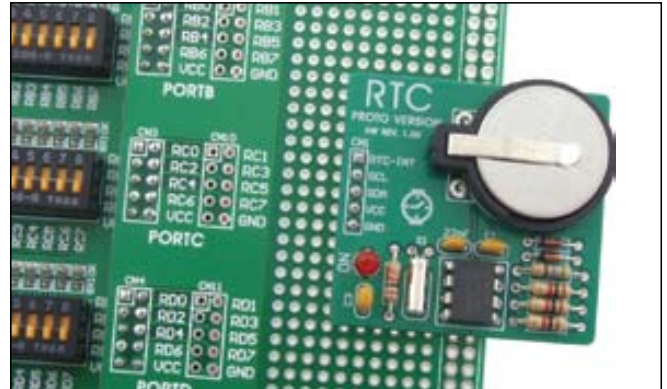

Figure 2: RTC PROTO placed on the development system

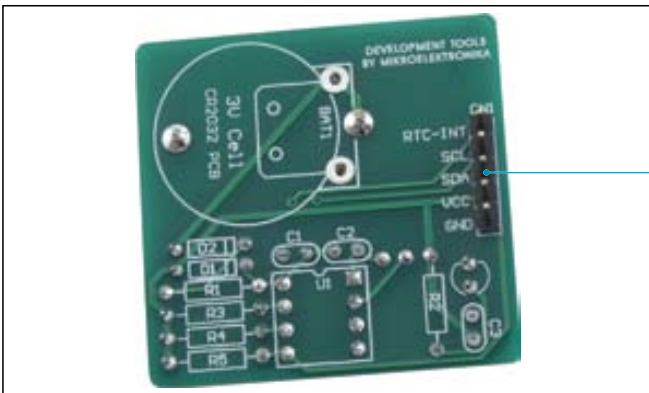

Figure 3: RTC PROTO's back side

1x5 male connector is used for connecting the additional board to the development system via proto board

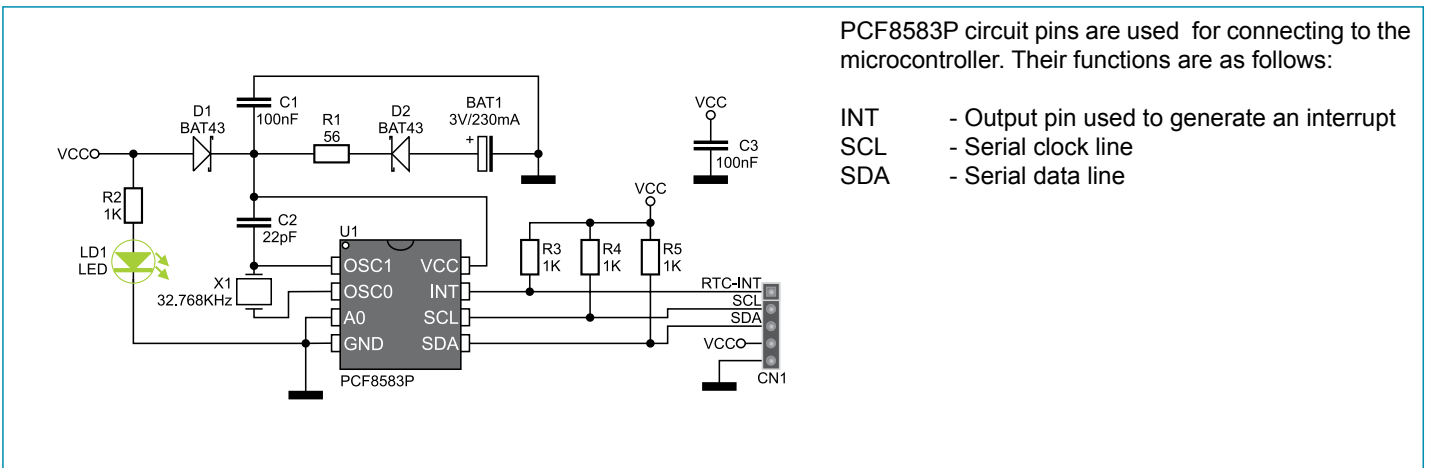

Figure 4: RTC PROTO connection schematic