

ZXNB4202
SINGLE LNB - COMPLETE BIAS, CONTROL AND POWER MANAGEMENT SOLUTION

CONFIDENTIAL

Summary

The ZXNB4202 is a single chip power management and control solution for LNB's. The highly integrated solution provides all the required FET and mixer bias, control detection and decoding, local oscillator switching and a stable power supply for the IF amplifier and additional support functions. Packaged in a small 16 pin package the ZXNB only requires 3 external components providing a very small compact solution. Being at the heart of the LNB monitoring the control, power management and environmental conditions, the ZXNB4202 is able to provide reliable solution eliminating effects such as false switching and over loading.

Features

- Single chip LNB bias, control and power management
- Integrated regulated supply for LNB
- Zero volt gate FET switching topology
- Voltage detection for polarization switching
- 22kHz tone detector with unwanted signal rejection for band switching
- No external control signal filtering required
- Programmable mixer and FET bias
- Temperature compensated protected FET bias
- Full power management protection

Application

- Single and Single Universal LNBs
- Mono-block LNB's
- C-band LNB's

Pin Assignments

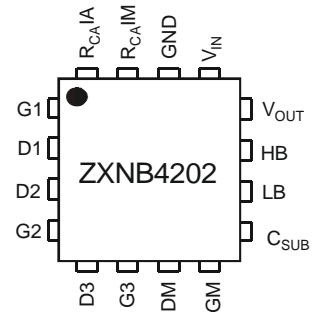

Top View

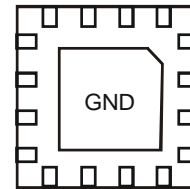

Bottom View

Single LNB System Diagram

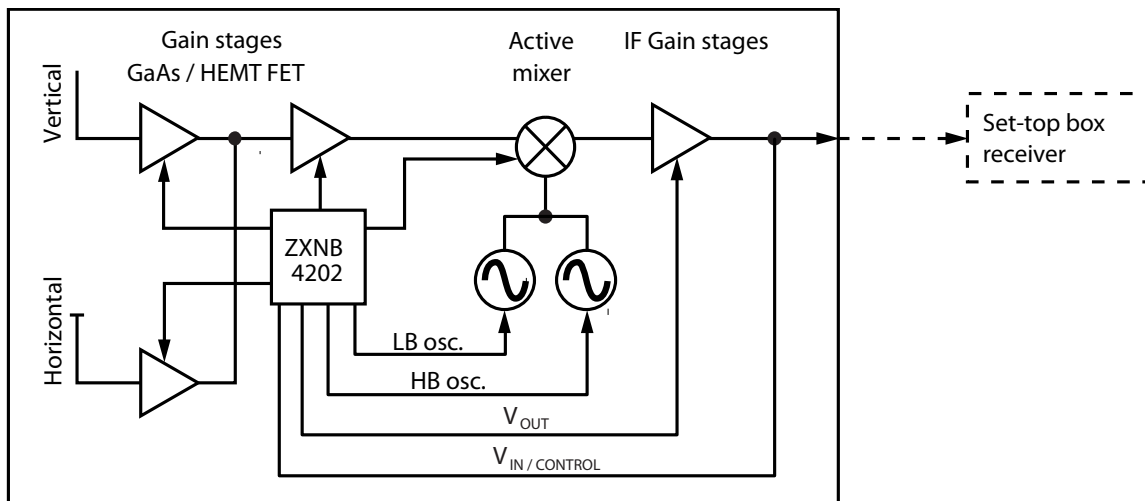

To Request This Datasheet
In Its Entirety Please Email

DBS@diodes.com

CONFIDENTIAL

IMPORTANT NOTICE

DIODES INCORPORATED MAKES NO WARRANTY OF ANY KIND, EXPRESS OR IMPLIED, WITH REGARDS TO THIS DOCUMENT, INCLUDING, BUT NOT LIMITED TO, THE IMPLIED WARRANTIES OF MERCHANTABILITY AND FITNESS FOR A PARTICULAR PURPOSE (AND THEIR EQUIVALENTS UNDER THE LAWS OF ANY JURISDICTION).

Diodes Incorporated and its subsidiaries reserve the right to make modifications, enhancements, improvements, corrections or other changes without further notice to this document and any product described herein. Diodes Incorporated does not assume any liability arising out of the application or use of this document or any product described herein; neither does Diodes Incorporated convey any license under its patent or trademark rights, nor the rights of others. Any Customer or user of this document or products described herein in such applications shall assume all risks of such use and will agree to hold Diodes Incorporated and all the companies whose products are represented on Diodes Incorporated website, harmless against all damages.

Diodes Incorporated does not warrant or accept any liability whatsoever in respect of any products purchased through unauthorized sales channel. Should Customers purchase or use Diodes Incorporated products for any unintended or unauthorized application, Customers shall indemnify and hold Diodes Incorporated and its representatives harmless against all claims, damages, expenses, and attorney fees arising out of, directly or indirectly, any claim of personal injury or death associated with such unintended or unauthorized application.

Products described herein may be covered by one or more United States, international or foreign patents pending. Product names and markings noted herein may also be covered by one or more United States, international or foreign trademarks.

LIFE SUPPORT

Diodes Incorporated products are specifically not authorized for use as critical components in life support devices or systems without the express written approval of the Chief Executive Officer of Diodes Incorporated. As used herein:

A. Life support devices or systems are devices or systems which:

1. are intended to implant into the body, or
2. support or sustain life and whose failure to perform when properly used in accordance with instructions for use provided in the labeling can be reasonably expected to result in significant injury to the user.

B. A critical component is any component in a life support device or system whose failure to perform can be reasonably expected to cause the failure of the life support device or to affect its safety or effectiveness.

Customers represent that they have all necessary expertise in the safety and regulatory ramifications of their life support devices or systems, and acknowledge and agree that they are solely responsible for all legal, regulatory and safety-related requirements concerning their products and any use of Diodes Incorporated products in such safety-critical, life support devices or systems, notwithstanding any devices- or systems-related information or support that may be provided by Diodes Incorporated. Further, Customers must fully indemnify Diodes Incorporated and its representatives against any damages arising out of the use of Diodes Incorporated products in such safety-critical, life support devices or systems.

Copyright © 2010, Diodes Incorporated

www.diodes.com