

Small Signal Diode

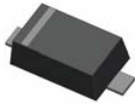

Features

- ✧ Fast switching device ($T_{rr} < 4.0\text{ns}$)
- ✧ Surface device type mounting
- ✧ Moisture sensitivity level 1
- ✧ Matte Tin (Sn) lead finish
- ✧ Pb free version, RoHS compliant
- ✧ Green compound (Halogen free) with suffix "G" on packing code and prefix "G" on date code

Mechanical Data

- ✧ Case : Flat lead SOD-523F small outline plastic package
- ✧ Terminal: Matte tin plated, lead free., solderable per MIL-STD-202, Method 208 guaranteed
- ✧ High temperature soldering guaranteed: 260 °C/10s
- ✧ Polarity : Indicated by cathode band
- ✧ Weight : 1.68±0.5 mg
- ✧ Marking Code : A

Ordering Information

Part No.	Packing Code	Package	Packing	Marking
1SS400	RK	SOD-523F	3K / 7" Reel	A
1SS400	RKG	SOD-523F	3K / 7" Reel	A

SOD-523F

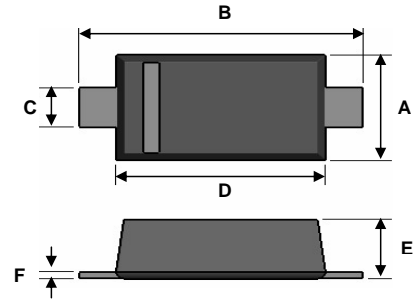

Dimensions	Unit (mm)		Unit (inch)	
	Min	Max	Min	Max
A	0.70	0.90	0.028	0.035
B	1.50	1.70	0.059	0.067
C	0.25	0.40	0.010	0.016
D	1.10	1.30	0.043	0.051
E	0.60	0.70	0.024	0.028
F	0.10	0.14	0.004	0.006

Pin Configuration



Suggested PAD Layout

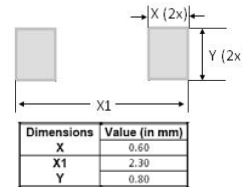

Maximum Ratings and Electrical Characteristics

Rating at 25°C ambient temperature unless otherwise specified.

Maximum Ratings

Type Number	Symbol	Value	Units
Power Dissipation	P_D	200	mW
Repetitive Peak Reverse Voltage	V_{RRM}	100	V
Reverse Voltage	V_R	100	V
Mean Forward Current	I_o	200	mA
Peak Forward Surge Current	I_{FSM}	500	mA
Thermal Resistance (Junction to Ambient)	$R\theta_{JA}$	625	°C/W
Storage Temperature Range	T_J, T_{STG}	-55 to + 150	°C

Small Signal Diode

Electrical Characteristics

Type Number		Symbol	Min	Max	Units
Breakdown Voltage	$I_R = 100\mu A$	$V_{(BR)}$	100	-	V
Forward Voltage	$I_F = 100mA$	V_F	-	1.20	V
Reverse Leakage Current	$V_R = 80V$	I_R	-	0.1	μA
Reverse Recovery Time	$I_F = 10mA$ $V_R = 6V$ $R_L = 100\Omega$	T_{RR}		4	nS
Junction Capacitance	$V_R = 0.5V$, $f = 1.0MHz$	C_J	-	4.0	pF

Tape & Reel specification

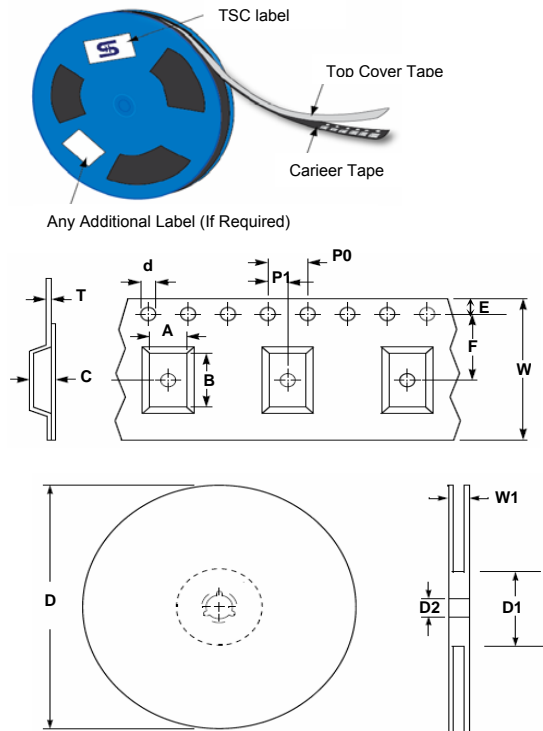

Item	Symbol	Dimension(mm)
Carrier width	A	1.7 ± 0.10
Carrier length	B	3.73 ± 0.10
Carrier depth	C	1.68 ± 0.10
Sprocket hole	d	1.5 ± 0.1
Reel outside diameter	D	178 ± 1
Reel inner diameter	D1	55 Min
Feed hole width	D2	13.0 ± 0.20
Sprocket hole position	E	1.75 ± 0.10
Punch hole position	F	3.50 ± 0.05
Sprocket hole pitch	P0	4.00 ± 0.10
Embossment center	P1	2.00 ± 0.05
Overall tape thickness	T	0.23 ± 0.05
Tape width	W	8.00 ± 0.20
Reel width	W1	14.4 Max

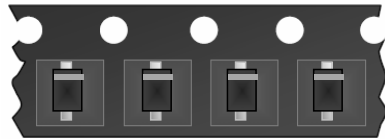

Small Signal Diode

Rating and Characteristic Curves

Fig. 1 Total Capacitance

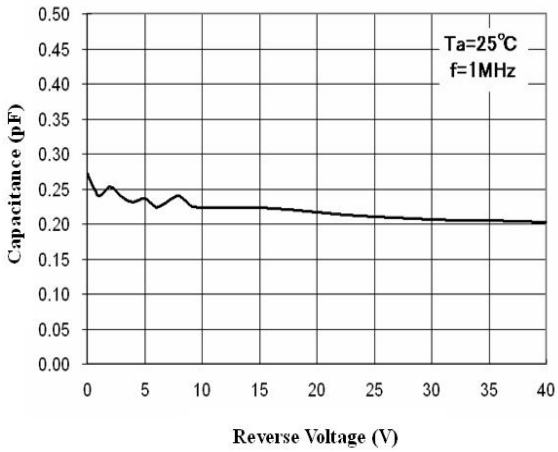

Fig. 2 Forward Voltage vs Ambient

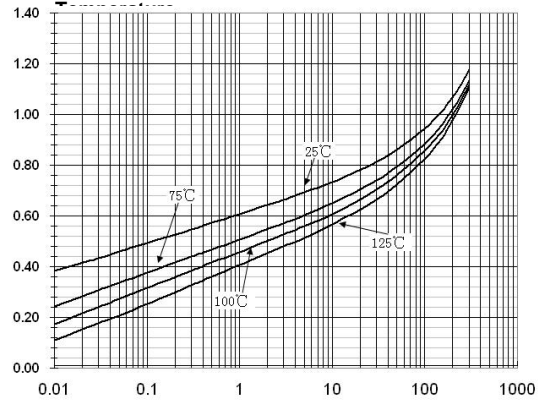

Fig. Power Derating Curve

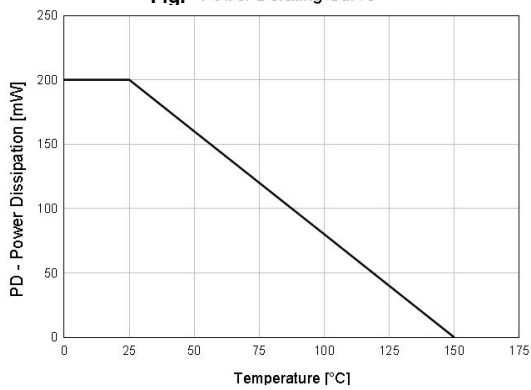

Fig. 4 Reverse Current vs Reverse

