



R4 Series
GPS Receiver Module
Data Guide

Wireless made simple[®]



Warning: Linx radio frequency (“RF”) products may be used to control machinery or devices remotely, including machinery or devices that can cause death, bodily injuries, and/or property damage if improperly or inadvertently triggered, particularly in industrial settings or other applications implicating life-safety concerns. No Linx Technologies product is intended for use in any application without redundancies where the safety of life or property is at risk.

The customers and users of devices and machinery controlled with RF products must understand and must use all appropriate safety procedures in connection with the devices, including without limitation, using appropriate safety procedures to prevent inadvertent triggering by the user of the device and using appropriate security codes to prevent triggering of the remote controlled machine or device by users of other remote controllers.

All RF products are susceptible to RF interference that can prevent communication. Lack of good sight of the GPS satellites (open sky) can affect the accuracy of a position fix or prevent a fix entirely.

Do not use any Linx product over the limits in this data guide.

Excessive voltage or extended operation at the maximum voltage could cause product failure. Exceeding the reflow temperature profile could cause product failure which is not immediately evident.

Do not make any physical or electrical modifications to any Linx product. This will void the warranty and regulatory and UL certifications and may cause product failure which is not immediately evident.



Warning: This product incorporates numerous static-sensitive components. Always wear an ESD wrist strap and observe proper ESD handling procedures when working with this device. Failure to observe this precaution may result in module damage or failure.



A large-print version of this document is available at www.linxtechnologies.com.

Table of Contents

1	Description
1	Features
1	Applications
2	Ordering Information
2	Electrical Specifications
3	Absolute Maximum Ratings
4	Pin Assignments
4	Pin Descriptions
5	A Brief Overview of GPS
5	Client Generated Extended Ephemeris (CGEE)
6	Time To First Fix (TTFF)
6	Module Description
7	Backup Battery
7	Power Supply Requirements
7	The 1PPS Output
8	Antenna Considerations
9	Power Control
10	Typical Applications
11	Slow Start Time
11	Protocols
12	Interfacing with NMEA Messages
13	Interfacing with NMEA Messages
13	CGA – Global Positioning System Fixed Data
14	GLL – Geographic Position – Latitude / Longitude
14	GSA – GNSS DOP and Active Settings
15	GSV – GNSS Satellites in View
16	RMC – Recommended Minimum Specific GNSS Data
17	VTG – Course Over Ground and Ground Speed

18	NMEA Input Messages
19	100 – SetSerialPort
20	101 – NavigationInitialization
21	103 – Query / Rate Control
23	104 – LLANavigationInitialization
24	105 – Development Data On / Off
25	Master Development System
26	Board Layout Guidelines
27	Pad Layout
28	Microstrip Details
29	Production Guidelines
29	Hand Assembly
30	Automated Assembly
31	Resources

R4 Series GPS Receiver

Data Guide



Description

The R4 Series GPS receiver module is a self-contained high-performance GPS receiver. Based on the SiRFstar IV chipset, it provides exceptional sensitivity, even in dense foliage and urban canyons. The module's very low power consumption helps maximize runtimes in battery powered applications. With over 200,000 effective correlators, the R4 Series receiver can acquire and track up to 48 satellites simultaneously in just seconds, even at the lowest signal levels. Housed in a compact reflow-compatible SMD package, the receiver requires no programming or additional RF components (except an antenna) to form a complete GPS solution. The module's standard NMEA data output makes the R4 Series easy to integrate, even by engineers without previous RF or GPS experience.

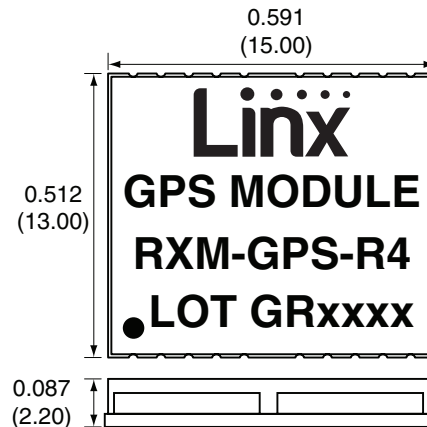

Figure 1: Package Dimensions

Features

- SiRF Star IV chipset
- Built-in jammer remover
- High sensitivity (-160dBm)
- 48 channels
- Fast TTFF at low signal levels
- Battery-backed SRAM
- CGEE allows 3-day prediction
- No programming necessary
- No external RF components needed (except an antenna)
- No production tuning
- Direct serial interface
- Power down feature
- Compact surface-mount package
- Manual or reflow compatible

Applications Include

- Positioning and Navigation
- Location and Tracking
- Security/Loss-Prevention
- Surveying
- Logistics
- Fleet Management

Ordering Information

Ordering Information	
Part Number	Description
RXM-GPS-R4-x	R4 Series GPS Receiver Module
MDEV-GPS-R4	R4 Series GPS Receiver Master Development System
EVM-GPS-R4	R4 Series GPS Receiver Evaluation Module

x = "T" for Tape and Reel, "B" for Bulk
 Reels are 1,000 pieces
 Quantities less than 1,000 pieces are supplied in bulk

Figure 2: Ordering Information

Electrical Specifications

R4 Series GPS Receiver Specifications						
Parameter	Symbol	Min.	Typ.	Max.	Units	Notes
Power Supply						
Operating Voltage	V_{CC}	3.0	3.3	3.6	VDC	
Supply Current	I_{CC}					
Peak				122	mA	1
Acquisition			56		mA	1
Tracking			33		mA	1
Hibernate			0.43		mA	1
Backup Battery Voltage	V_{BAT}	2.0		6.0	VDC	
Backup Battery Current	I_{BAT}		660	830	μ A	2
VOUT Output Voltage	V_{OUT}		VCC			3
Output Low Voltage	V_{OL}			0.4	VDC	
Output High Voltage	V_{OH}					
TX Pin		0.7*VCC	VCC	VCC	VDC	
1.8V Level Pin		1.2	1.8	1.85	VDC	
Output Low Current	I_{OL}		2.0		mA	
Output High Current	I_{OH}					
TX Pin			0.05		mA	
1.8V Level Pin			2.0		mA	
Input Low Voltage	V_{IL}	-0.4		0.45	VDC	
Input High Voltage	V_{IH}	1.3		3.6	VDC	
LNA Section						
Input Power	P_{IN}			18	dB	

Receiver Section						
Receiver Sensitivity						
Tracking			-160		dBm	
Navigation			-157		dBm	
Cold Start			-145		dBm	
Acquisition Time						
Hot Start (Open Sky)				1	s	
Hot Start (Indoor)				15	s	
Cold Start			32		s	
Cold Start, CGEE			15		s	
Position Accuracy						
Autonomous			2.5		m	
SBAS			2.5		m	
Altitude				18,000	m	
Velocity				515	m/s	
Chipset	SiRF Star IV, GSD4e ROM					
Frequency	L1 1575.42MHz, C/A Code					
Channels	48					
Update Rate	1Hz					
Protocol Support	NMEA 0183 ver 3.0, SiRF Binary					
Antenna Port						
RF Impedance	R_{IN}		50		Ω	

1. VCC = 3.3V, without active antenna
2. VCC = 0V
3. VOUT current is directly sourced from VCC.

Figure 3: Electrical Specifications

Absolute Maximum Ratings

Absolute Maximum Ratings				
Supply Voltage V_{CC}	+4.3			VDC
Input Battery Backup Voltage	+7.0			VDC
Operating Temperature	-40	to	+85	°C
Storage Temperature	-40	to	+85	°C
Soldering Temperature	+225°C for 10 seconds			

Exceeding any of the limits of this section may lead to permanent damage to the device. Furthermore, extended operation at these maximum ratings may reduce the life of this device.

Figure 4: Absolute Maximum Ratings

Pin Assignments

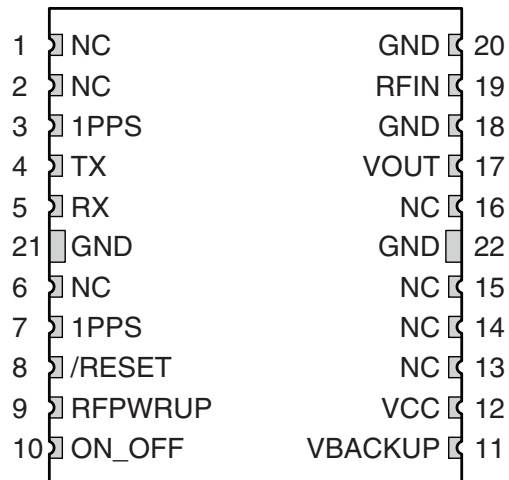

Figure 5: R4 Series GPS Receiver Pinout (Top View)

Pin Descriptions

Pin Descriptions			
Pin Number	Name	I/O	Description
1, 2, 6, 13, 14, 15, 16, 17	NC	-	No electrical connection.
3, 7	1PPS	O	1 Pulse Per Second. 1.8V level.
4	TX	O	Serial output (default NMEA)
5	RX	I	Serial input (default NMEA)
8	/RESET	I	Reset input, active low. The module has an internal power-on reset circuit so this pin can be left floating
9	RFPWRUP	O	Power State Indicator
10	ON_OFF	I	Power Control Pin. If this pin is not used, leave it floating.
11	VBACKUP	P	Backup battery supply voltage. This line must be powered to enable the module.
12	VCC	P	Supply Voltage
18, 20, 21, 22	GND	P	Ground
17	VOUT	O	VCC voltage to supply an active antenna.
19	RFIN	I	GPS RF signal input

Figure 6: R4 Series GPS Receiver Pin Descriptions

A Brief Overview of GPS

The Global Positioning System (GPS) is a U.S.-owned utility that freely and continuously provides positioning, navigation, and timing (PNT) information. Originally created by the U.S. Department of Defense for military applications, the system was made available without charge to civilians in the early 1980s. The global positioning system consists of a nominal constellation of 24 satellites orbiting the earth at about 12,000 nautical miles in height. The pattern and spacing of the satellites allow at least four to be visible above the horizon from any point on the Earth. Each satellite transmits low power radio signals which contain three different bits of information; a pseudorandom code identifying the satellite, ephemeris data which contains the current date and time as well as the satellite's health, and the almanac data which tells where each satellite should be at any time throughout the day.

A GPS receiver receives and times the signals sent by multiple satellites and calculates the distance to each satellite. If the position of each satellite is known, the receiver can use triangulation to determine its position anywhere on the earth. The receiver uses four satellites to solve for four unknowns; latitude, longitude, altitude and time. If any of these factors is already known to the system, an accurate position (fix) can be obtained with fewer satellites in view. Tracking more satellites improves calculation accuracy. In essence, the GPS system provides a unique address for every square meter on the planet.

A faster Time To First Fix (TTFF) is also possible if the satellite information is already stored in the receiver. If the receiver knows some of this information, then it can accurately predict its position before acquiring an updated position fix. For example, aircraft or marine navigation equipment may have other means of determining altitude, so the GPS receiver would only have to lock on to three satellites and calculate three equations to provide the first position fix after power-up.

Client Generated Extended Ephemeris (CGEE)

CGEE is a type of assisted GPS (AGPS) where the receiver uses the ephemeris data broadcast by the satellites to calculate models of each visible satellite's future location. This allows the receiver to store up to 3 days worth of ephemeris data and results in faster TTFF.

Time To First Fix (TTFF)

TTFF is often broken down into three parts:

Cold: A cold start is when the receiver has no accurate knowledge of its position or time. This happens when the receiver's internal Real Time Clock (RTC) has not been running or it has no valid ephemeris or almanac data. In a cold start, the receiver takes 35 to 40 seconds to acquire its position.

Warm or Normal: A typical warm start is when the receiver has valid almanac and time data and has not significantly moved since its last valid position calculation. This happens when the receiver has been shut down for more than 2 hours, but still has its last position, time, and almanac saved in memory, and its RTC has been running. The receiver can predict the location of the current visible satellites and its location; however, it needs to wait for an ephemeris broadcast (every 30 seconds) before it can accurately calculate its position.

Hot or Standby: A hot start is when the receiver has valid ephemeris, time, and almanac data. This happens when the receiver has been shut down for less than 2 hours and has the necessary data stored in memory with the RTC running. In a hot start, the receiver takes 1 second to acquire its position. The time to calculate a fix in this state is sometimes referred to as Time to Subsequent Fix or TTTF.

Module Description

The R4 Series GPS Receiver module is based on the SiRFstarIV chipset, which consumes less power than competitive products while providing exceptional performance even in dense foliage and urban canyons. No external RF components are needed other than an antenna. The simple serial interface and industry standard NMEA protocol make integration of the R4 Series receiver into an end product extremely straightforward.

The module's high-performance RF architecture allows it to receive GPS signals that are as low as -160dBm . The R4 Series can track up to 48 satellites at the same time. Once locked onto the visible satellites, the receiver calculates the range to the satellites and determines its position and the precise time. It then outputs the data through a standard serial port using several standard NMEA protocol formats.

The GPS core handles all of the necessary initialization, tracking, and calculations autonomously, so no programming is required. The RF section is optimized for low level signals, and requires no production tuning.

Backup Battery

The module is designed to work with a backup battery that keeps the SRAM memory and the RTC powered when the RF section and the main GPS core are powered down. This enables the module to have a faster Time To First Fix (TTFF) when the it is powered back on. The memory and clock pull about 660 μ A. This means that a small lithium battery is sufficient to power these sections. This significantly reduces the power consumption and extends the main battery life while allowing for fast position fixes when the module is powered back on.

The backup battery must be installed for CGEE start. If the serial command is used to place the receiver into hibernate while keeping VCC powered, then the battery backup current is 15 μ A while the current through the VCC line is about 170 μ A.

Power Supply Requirements

The module requires a clean, well-regulated power source. While it is preferable to power the unit from a battery, it can operate from a power supply as long as noise is less than 20mV. Power supply noise can significantly affect the receiver's sensitivity, therefore providing clean power to the module should be a high priority during design. Bypass capacitors should be placed as close as possible to the module. The values should be adjusted depending on the amount and type of noise present on the supply line.

The 1PPS Output

The 1PPS line outputs 1 pulse per second on the rising edge of the GPS second when the receiver has an over-solved navigation solution from five or more satellites. The pulse has a duration of 200ms with the rising edge on the GPS second. This line is low until the receiver acquires an over-solved navigation solution (a lock on more than 4 satellites). The GPS second is based on the atomic clocks in the GPS satellites, which are monitored and set to Universal Time master clocks. This output and the time calculated from the GPS satellite transmissions can be used as a clock feature in an end product.

Antenna Considerations

The R4 Series module is designed to utilize a wide variety of external antennas. The module has a regulated power output which simplifies the use of GPS antenna styles which require external power. This allows the designer great flexibility, but care must be taken in antenna selection to ensure optimum performance. For example, a handheld device may be used in many varying orientations so an antenna element with a wide and uniform pattern may yield better overall performance than an antenna element with high gain and a correspondingly narrower beam. Conversely, an antenna mounted in a fixed and predictable manner may benefit from pattern and gain characteristics suited to that application. Evaluating multiple antenna solutions in real-world situations is a good way to rapidly assess which will best meet the needs of your application.

For GPS, the antenna should have good right hand circular polarization characteristics (RHCP) to match the polarization of the GPS signals. Ceramic patches are the most commonly used style of antenna, but there are many different shapes, sizes and styles of antennas available. Regardless of the construction, they will generally be either passive or active types. Passive antennas are simply an antenna tuned to the correct frequency. Active antennas add a Low Noise Amplifier (LNA) after the antenna and before the module to amplify the weak GPS satellite signals.

For active antennas, a 300 ohm ferrite bead can be used to connect the VOUT line to the RFIN line. This bead prevents the RF from getting into the power supply, but allows the DC voltage onto the RF trace to feed into the antenna. A series capacitor inside the module prevents this DC voltage from affecting the bias on the module's internal LNA. The VOUT line is connected to the VCC line, so the voltage is the module supply voltage and the current sourcing depends on the module's power supply.

Maintaining a 50 ohm path between the module and antenna is critical. Errors in layout can significantly impact the module's performance. Please review the layout guidelines elsewhere in this guide carefully to become more familiar with these considerations.

Power Control

The R4 Series GPS Receiver module offers two power control modes: Full Power and Hibernate. In Full Power mode the module is fully active and continuously tracking. Measurements are of the highest quality and are continuously output by the module. This is the highest current consumption state.

Hibernate mode is the lowest power setting. The tracking and processor blocks are powered down, but the RTC is still running and the memory blocks are still powered enabling a hot start.

The module switches between these states by toggling the ON_OFF line. The ON_OFF line must go high for at least 100ms to trigger the change of state and must remain low for at least 100ms to reset the edge detector.

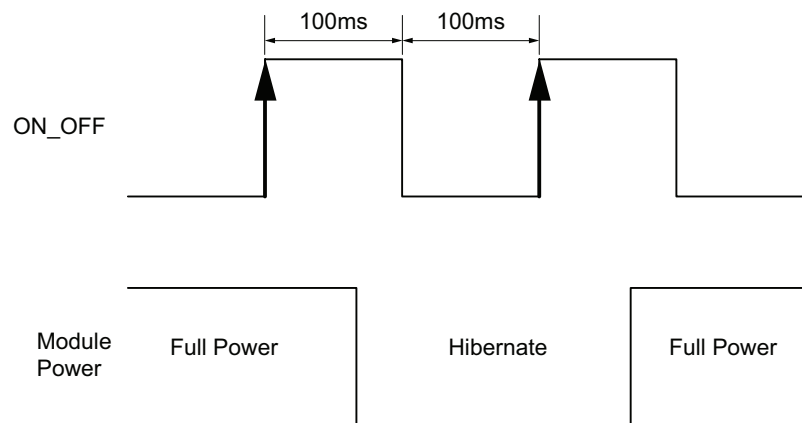

Figure 7: R4 Series GPS Receiver Power Control

If the module is in Full Power mode, a pulse on the ON_OFF line will initiate an orderly shutdown into Hibernate mode. If the module is in Hibernate mode, a pulse on the ON_OFF line will transition the module into Full Power Mode.

Typical Applications

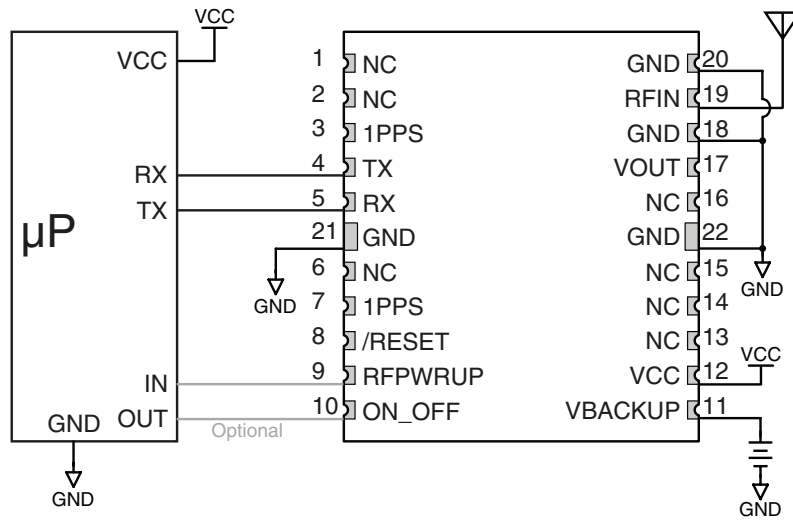

Figure 8: Circuit Using the R4 Series Module with a Passive Antenna

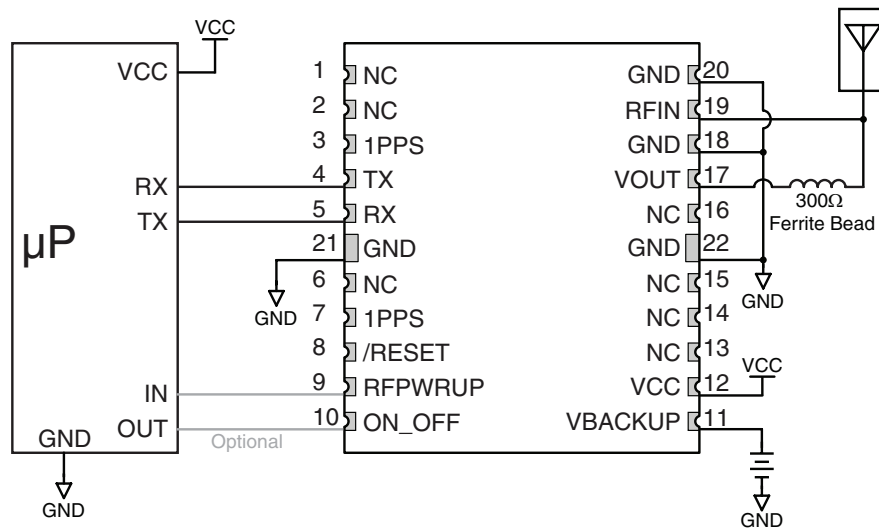

Figure 9: Circuit Using the R4 Series Module with an Active Antenna

Slow Start Time

The most critical factors in start time are current ephemeris data, signal strength and sky view. The ephemeris data describes the path of each satellite as they orbit the earth. This is used to calculate the position of a satellite at a particular time. This data is only usable for a short period of time, so if it has been more than a few hours since the last fix or if the location has significantly changed (a few hundred miles), then the receiver may need to wait for a new ephemeris transmission before a position can be calculated. The GPS satellites transmit the ephemeris data every 30 seconds. Transmissions with a low signal strength may not be received correctly or be corrupted by ambient noise. The view of the sky is important because the more satellites the receiver can see, the faster the fix and the more accurate the position will be when the fix is obtained.

If the receiver is in a very poor location, such as inside a building, urban canyon, or dense foliage, then the time to first fix can be slowed. In very poor locations with poor signal strength and a limited view of the sky with outdated ephemeris data, this could be on the order of several minutes. In the worst cases, the receiver may need to receive almanac data, which describes the health and course data for every satellite in the constellation. This data is transmitted every 15 minutes. If a lock is taking a long time, try to find a location with a better view of the sky and fewer obstructions. Once locked, it is easier for the receiver to maintain the position fix.

Protocols

Linx GPS modules use the SiRFstar IV chipset. This chipset allows two protocols to be used, NMEA-0183 and SiRF Binary. Switching between the two is handled using a single serial command. The NMEA protocol uses ASCII characters for the input and output messages and provides the most common features of GPS development in a small command set. The SiRF Binary protocol uses BYTE data types and allows more detailed control over the GPS receiver and its functionality using a much larger command set. Although both protocols have selectable baud rates, it's recommended that SiRF Binary use 115,200bps. For a detailed description of the SiRF Binary protocol, see the SiRF Binary Protocol Reference Manual, available from SiRF Technology, Inc.

Note: Although SiRF Binary protocol may be used with the module, Linx only offers tech support for the NMEA protocol.

Interfacing with NMEA Messages

Linux modules default to the NMEA protocol. Output messages are sent from the receiver on the TX pin and input messages are sent to the receiver on the RX pin. By default, output messages are sent once every second. Details of each message are described in the following sections.

The NMEA message format is as follows: <Message-ID + Data Payload + Checksum + End Sequence>. The serial data structure defaults to 9,600bps, 8 data bits, 2 stop bits, and no parity bits. Each message starts with a \$ character and ends with a <CR> <LF>. All fields within each message are separated by a comma. The checksum follows the * character and is the last two characters, not including the <CR> <LF>. It consists of two hex digits representing the exclusive OR (XOR) of all characters between, but not including, the \$ and * characters. When reading NMEA output messages, if a field has no value assigned to it, the comma will still be placed following the previous comma. For example, {,04,,,,,2.0,} shows four empty fields between values 04 and 2.0. When writing NMEA input messages, all fields are required, none are optional. An empty field will invalidate the message and it will be ignored.

Reading NMEA output messages:

- Initialize a serial interface to match the serial data structure of the GPS receiver.
- Read the NMEA data from the TX pin into a receive buffer.
- Separate it into six buffers, one for each message type. Use the characters (\$) and <CR> <LF> as end points for each message.
- For each message, calculate the checksum as mentioned above to compare with the received checksum.
- Parse the data from each message using commas as field separators.
- Update the application with the parsed field values.
- Clear the receive buffer and be ready for the next set of messages.

Writing NMEA input messages:

- Initialize a serial interface to match the serial data structure of the GPS receiver.
- Assemble the message to be sent with the calculated checksum.
- Transmit the message to the receiver on the RX pin.

Interfacing with NMEA Messages

The following sections outline the data structures of the various NMEA protocols that are supported by the module. By default, the NMEA commands are output at 9,600bps, 8 data bits, no parity and 1 stop bit.

GGA – Global Positioning System Fixed Data

Figure 10 below contains the values for the following example:

`$GPGGA,053740.000,2503.6319,N,12136.0099,E,1,08,1.1,63.8,M,15.2,M,,0000*64`

Global Positioning System Fixed Data Example			
Name	Example	Units	Description
Message ID	\$GPGGA		GGA protocol header
UTC Time	053740.000		hhmmss.sss
Latitude	2503.6319		ddmm.mmmm
N/S Indicator	N		N=north or S=south
Longitude	12136.0099		dddmm.mmmm
E/W Indicator	E		E=east or W=west
Position Fix Indicator	1		See Figure 11
Satellites Used	08		Range 0 to 12.
HDOP	1.1		Horizontal Dilution of Precision
MSL Altitude	63.8	meters	
Units	M	meters	
Geoid Separation	15.2	meters	
Units	M	meters	
Age of Diff. Corr.		second	Null fields when DGPS is not used
Diff. Ref. Station	0000		
Checksum	*64		
<CR> <LF>			End of message termination

Figure 10: Global Positioning System Fixed Data Example

Position Indicator Values	
Value	Description
0	Fix not available or invalid
1	GPS SPS Mode, fix valid
2	Differential GPS, SPS Mode, fix valid
3–5	Not supported
6	Dead Reckoning Mode, fix valid

Figure 11: Position Indicator Values

GLL – Geographic Position – Latitude / Longitude

Figure 12 below contains the values for the following example:

`$GPGLL,2503.6319,N,12136.0099,E,053740.000,A,A*52`

Geographic Position – Latitude / Longitude Example			
Name	Example	Units	Description
Message ID	\$GPGLL		GLL protocol header
Latitude	2503.6319		ddmm.mmmmm
N/S Indicator	N		N=north or S=south
Longitude	12136.0099		dddmm.mmmmm
E/W Indicator	E		E=east or W=west
UTC Time	053740.000		hhmmss.sss
Status	A		A=data valid or V=data not valid
Mode	A		A=autonomous, D=DGPS, N=Data not valid
Checksum	*52		
<CR> <LF>			End of message termination

Figure 12: Geographic Position – Latitude / Longitude Example

GSA – GNSS DOP and Active Satellites

Figure 13 below contains the values for the following example:

`$GPGSA,A,3,24,07,17,11,28,08,20,04,,,,,2.0,1.1,1.7*35`

GNSS DOP and Active Satellites Example			
Name	Example	Units	Description
Message ID	\$GPGSA		GSA protocol header
Mode 1	A		See Figure 14
Mode 2	3		1=No fix, 2=2D, 3=3D
ID of satellite used	24		Sv on Channel 1
ID of satellite used	07		Sv on Channel 2
...			...
ID of satellite used			Sv on Channel 12
PDOP	2.0		Position Dilution of Precision
HDOP	1.1		Horizontal Dilution of Precision
VDOP	1.7		Vertical Dilution of Precision
Checksum	*35		
<CR> <LF>			End of message termination

Figure 13: GNSS DOP and Active Satellites Example

Mode 1 Values	
Value	Description
M	Manual – forced to operate in 2D or 3D mode
A	Automatic – allowed to automatically switch 2D/3D

Figure 14: Mode 1 Values

GSV – GNSS Satellites in View

Figure 15 below contains the values for the following example:

`$GPGSV,3,1,12,28,81,285,42,24,67,302,46,31,54,354,,20,51,077,46*73`

`$GPGSV,3,2,12,17,41,328,45,07,32,315,45,04,31,250,40,11,25,046,41*75`

`$GPGSV,3,3,12,08,22,214,38,27,08,190,16,19,05,092,33,23,04,127,*7B`

GNSS Satellites in View Example			
Name	Example	Units	Description
Message ID	\$GPGSV		GSV protocol header
Total number of messages ¹	3		Range 1 to 3
Message number ¹	1		Range 1 to 3
Satellites in view	12		
Satellite ID	28		Channel 1 (Range 01 to 196)
Elevation	81	degrees	Channel 1 (Range 00 to 90)
Azimuth	285	degrees	Channel 1 (Range 000 to 359)
SNR (C/No)	42	dB-Hz	Channel 1 (Range 00 to 99, null when not tracking)
Satellite ID	20		Channel 4 (Range 01 to 32)
Elevation	51	degrees	Channel 4 (Range 00 to 90)
Azimuth	077	degrees	Channel 4 (Range 00 to 359)
SNR (C/No)	46	dB-Hz	Channel 4 (Range 00 to 99, null when not tracking).
Checksum	*73		
<CR> <LF>			End of message termination

1. Depending on the number of satellites tracked, multiple messages of GSV data may be required.

Figure 15: GNSS Satellites in View Example

RMC – Recommended Minimum Specific GNSS Data

Figure 16 below contains the values for the following example:

`$GPRMC,053740.000,A,2503.6319,N,12136.0099,E,2.69,79.65,100106,,,A*53`

Recommended Minimum Specific GNSS Data Example			
Name	Example	Units	Description
Message ID	\$GPRMC		RMC protocol header
UTC Time	053740.000		hhmmss.sss
Status	A		A=data valid or V=data not valid
Latitude	2503.6319		ddmm.mmmm
N/S Indicator	N		N=north or S=south
Longitude	12136.0099		dddmm.mmmm
E/W Indicator	E		E=east or W=west
Speed over ground	2.69	knots	TRUE
Course over ground	79.65	degrees	
Date	100106		ddmmyy
Magnetic Variation		degrees	Not available, null field
Variation Sense			E=east or W=west (not shown)
Mode	A		A=autonomous, D=DGPS, N= Data not valid
Checksum	*53		
<CR> <LF>			End of message termination

Figure 16: Recommended Minimum Specific GNSS Data Example

VTG – Course Over Ground and Ground Speed

Figure 17 below contains the values for the following example:

`$GPVTG,79.65,T,,M,2.69,N,5.0,K,A*38`

Course Over Ground and Ground Speed Example			
Name	Example	Units	Description
Message ID	\$GPVTG		VTG protocol header
Course over ground	79.65	degrees	Measured heading
Reference	T		TRUE
Course over ground		degrees	Measured heading (N/A, null field)
Reference	M		Magnetic
Speed over ground	2.69	knots	Measured speed
Units	N		Knots
Speed over ground	5.0	km/hr	Measured speed
Units	K		Kilometer per hour
Mode	A		A=autonomous, D=DGPS, N= Data not valid
Checksum	*38		
<CR> <LF>			End of message termination

Figure 17: Course Over Ground and Ground Speed Example

NMEA Input Messages

The following outlines the serial commands input into the module for configuration. By default, the commands are input at 9,600bps, 8 data bits, no parity and 2 stop bits.

Serial Data Structure		
Name	Example	Description
Start Sequence	\$PSRF	
Message ID	<MID>	Message Identifier consisting of three numeric characters. Input messages begin at MID 100.
Payload	DATA	Message specific data.
Checksum	CKSUM	CKSUM is a two-hex character checksum as defined in the NMEA specification, NMEA-0183 Standard for Interfacing Marine Electronic Devices. Checksums are required on all input messages.
End Sequence	<CR> <LF>	Each message must be terminated using Carriage Return (CR) Line Feed (LF) (\r\n, 0x0D0A) to cause the receiver to process the input message. They are not printable ASCII characters, so are omitted from the examples.

Figure 18: Serial Data Structure

All fields in all proprietary NMEA messages are required; none are optional. All NMEA messages are comma delimited. Figure 19 below outlines the message identifiers supported by the module.

Message ID Values		
Name	MID	Description
SetSerialPort	100	Set PORT A parameters and protocol
NavigationInitialization	101	Reset the modules
Query/Rate Control	103	Query standard NMEA message and/or set output rate
LLANavigationInitialization	104	Reset the modules
Development Data On/Off	105	Development Data messages On/Off
System Turn Off	117	Performs an orderly shut down of the module and switches into hibernation mode

Figure 19: Message ID Values

100 – SetSerialPort

This command message is used to set the protocol (SiRF binary or NMEA) and/or the communication parameters (baud rate). Generally, this command is used to switch the module back to SiRF binary protocol mode where a more extensive command message set is available. When a valid message is received, the parameters are stored in battery-backed SRAM and the receiver restarts using the saved parameters.

Figure 20 below contains the values for the following example:

Switch to SiRF binary protocol at 9600,8,N,1

`$PSRF100,0,9600,8,1,0*0C`

SetSerialPort Example		
Name	Example	Description
Message ID	\$PSRF100	PSRF100 protocol header
Protocol	0	0=SiRF binary, 1=NMEA
Baud	9600	4800, 9600, 19200, 38400, 57600, 115200
DataBits	8	8 ¹
StopBits	1	0, 1 ¹
Parity	0	0=None, 1=Odd, 2=Even ¹
Checksum	*0C	
<CR> <LF>		End of message termination

1. SiRF protocol is only valid for 8 data bits, 1 stop bit and no parity.
2. Default settings are NMEA protocol using 9,600 baud, 8 data bits, 2 stop bits and no parity.

Figure 20: SetSerialPort Example

For details on the SiRF binary protocol, please refer to SiRF's Binary Protocol Reference Manual.

101 – NavigationInitialization

This command is used to initialize the receiver with the current position (in X, Y, Z coordinates), clock offset, and time, enabling a faster fix. Increased receiver sensitivity and the removal of Selective Availability (SA) have made this unnecessary. The command is retained for its ability to reset the module, but the initialization fields are no longer supported.

Figure 21 below contains the values for the following example:

`$PSRF101,-2686700,-4304200,3851624,96000,497260,921,12,3*1C`

NavigationInitialization Example			
Name	Example	Units	Description
Message ID	\$PSRF101		PSRF101 protocol header
ECEF X	-2686700	meters	X coordinate position
ECEF Y	-4304200	meters	Y coordinate position
ECEF Z	3851624	meters	Z coordinate position
ClkOffset	96000	Hz	Clock Offset ¹
TimeOfWeek	497260	seconds	GPS Time Of Week
WeekNo	921		GPS Week Number
ChannelCount	12		Range 1 to 12
ResetCfg	3		See Figure 22
Checksum	*1F		
<CR> <LF>			End of message termination

1. Use 0 for the last saved value if available. If this is unavailable, a default value of 96000 is used.

Figure 21: NavigationInitialization Example

ResetCfg Values	
Hex	Description
0x01	Hot Start – All data valid
0x02	Warm Start – Ephemeris cleared
0x04	Cold Start – Clears all data in memory
0x08	Clear Memory – Clears all data in memory and resets the receiver back to factory defaults

Figure 22: ResetCfg Values

103 – Query / Rate Control

This command is used to control the output of standard NMEA messages GGA, GLL, GSA, GSV, RMC and VTG. Using this command message, standard NMEA messages may be polled once, or setup for periodic output. Checksums may also be enabled or disabled depending on the needs of the receiving program. NMEA message settings are saved in battery-backed memory for each entry when the message is accepted.

Figure 23 below contains the values for the following example:

1. Query the GGA message with checksum enabled
*\$PSRF103,00,01,00,01*25*
2. Enable VTG message for a 1Hz constant output with checksum enabled
*\$PSRF103,05,00,01,01*20*
3. Disable VTG message
*\$PSRF103,05,00,00,01*21*

Query / Rate Control Example ¹			
Name	Example	Units	Description
Message ID	\$PSRF103		PSRF103 protocol header
Msg	00		See Figure 24
Mode	01		0=SetRate, 1=Query
Rate	00	seconds	Output: off=0, max=255
CksumEnable	01		0=Disable, 1=Enable Checksum
Checksum	*25		
<CR> <LF>			End of message termination

1. Default setting is GGA, GLL, GSA, GSV, RMC and VTG NMEA messages are enabled with checksum at a rate of 1 second.

Figure 23: Query / Rate Control Example

MSGValues	
Value	Description
0	GGA
1	GLL
2	GSA
3	GSV
4	RMC
5	VTG
6	MSS (not supported)
7	Not defined
8	ZDA
9	Not defined

Figure 24: MSG Values

104 – LLANavigationInitialization

This command is used to initialize the receiver with the current position (in latitude, longitude and altitude coordinates), clock offset, and time, enabling a faster fix. Increased receiver sensitivity and the removal of Selective Availability (SA) have made this unnecessary. The command is retained for its ability to reset the module, but the initialization fields are no longer supported.

Figure 25 below contains the values for the following example:

```
$PSRF104,37.3875111,-121.97232,0,96000,237759,1946,12,1*07
```

LLANavigationInitialization Example			
Name	Example	Units	Description
Message ID	\$PSRF104		PSRF104 protocol header
Latitude	37.3875111	degrees	Latitude position (Range 90 to -90)
Longitude	-121.97232	degrees	Longitude position (Range 180 to -180)
Altitude	0	meters	Altitude position
ClkOffset	96000	Hz	Clock Offset of the Evaluation Receiver1
TimeOfWeek	237759	seconds	GPS Time Of Week
WeekNo	1946		Extended GPS Week Number (1024 added)
ChannelCount	12		Range 1 to 12
ResetCfg	1		See Figure 26
Checksum	*07		
<CR> <LF>			End of message termination

1. Use 0 for the last saved value if available. If this is unavailable, a default value of 96000 is used.

Figure 25: NavigationInitialization Example

ResetCfg Values	
Hex	Description
0x01	Hot Start – All data valid
0x02	Warm Start – Ephemeris cleared
0x04	Cold Start – Clears all data in memory
0x08	Clear Memory – Clears all data in memory and resets the receiver back to factory defaults

Figure 26: ResetCfg Values

105 – Development Data On / Off

Use this command to enable development data information if you are having trouble getting commands accepted. Invalid commands generate debug information that helps to determine the source of the command rejection. Common reasons for input command rejection are invalid checksum or parameter out of specified range.

Figure 27 below contains the values for the following example:

1. Debug On
*\$PSRF105,1*3E*
2. Debug Off
*\$PSRF105,0*3F*

Development Data On / Off Example ¹			
Name	Example	Units	Description
Message ID	\$PSRF105		PSRF105 protocol header
Debug	1		0=Off, 1=On
Checksum	*3E		
<CR> <LF>			End of message termination

1. Default setting is debug mode off.

Figure 27: Development Data On / Off Example

117 – System Turn Off

This message requests that the GPS receiver perform an orderly shutdown and switch to hibernate mode.

Figure 28 below contains the values for the following example:

*\$PSRF117,16*0B*

System Turn Off Example			
Name	Example	Units	Description
Message ID	\$PSRF117		PSRF117 protocol header
Sub ID	16		16: System turn off
Checksum	*0B		
<CR> <LF>			End of message termination

Figure 28: System Turn Off Example

Master Development System

The R4 Series Master Development System provides all of the tools necessary to evaluate the R4 Series GPS receiver module. The system includes a fully assembled development board, an active antenna, development software and full documentation.



Figure 29: The R4 Series Master Development System

The development board includes a power supply, a prototyping area for custom circuit development, and an OLED display that shows the GPS data without the need for a computer. A USB interface is also included for use with a PC running custom software or the included development software.

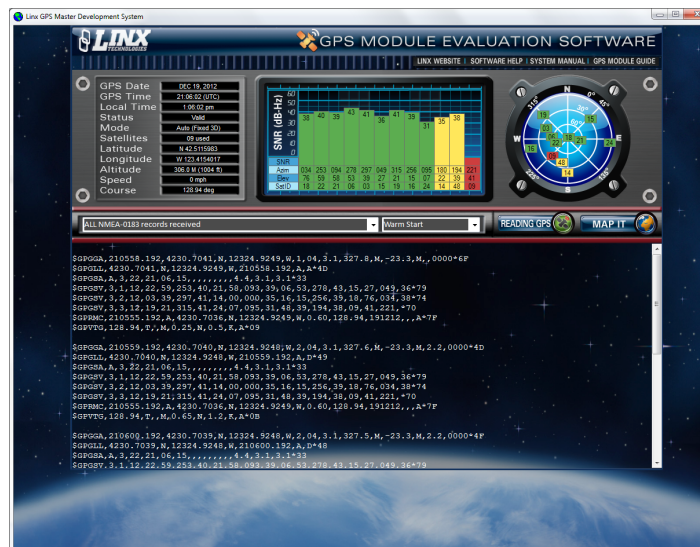

Figure 30: The R4 Series Master Development System Software

The Master Development System software enables configuration of the receiver and displays the satellite data output by the receiver. The software can select from among all of the supported NMEA protocols for display of the data.

Full documentation for the board and software is included in the development system, making integration of the module straightforward.

Board Layout Guidelines

The module's design makes integration straightforward; however, it is still critical to exercise care in PCB layout. Failure to observe good layout techniques can result in a significant degradation of the module's performance. A primary layout goal is to maintain a characteristic 50-ohm impedance throughout the path from the antenna to the module. Grounding, filtering, decoupling, routing and PCB stack-up are also important considerations for any RF design. The following section provides some basic design guidelines which may be helpful.

During prototyping, the module should be soldered to a properly laid-out circuit board. The use of prototyping or "perf" boards will result in poor performance and is strongly discouraged.

The module should, as much as reasonably possible, be isolated from other components on your PCB, especially high-frequency circuitry such as crystal oscillators, switching power supplies, and high-speed bus lines.

When possible, separate RF and digital circuits into different PCB regions. Make sure internal wiring is routed away from the module and antenna, and is secured to prevent displacement.

Do not route PCB traces directly under the module. There should not be any copper or traces under the module on the same layer as the module, just bare PCB. The underside of the module has traces and vias that could short or couple to traces on the product's circuit board.

The Pad Layout section shows a typical PCB footprint for the module. A ground plane (as large and uninterrupted as possible) should be placed on a lower layer of your PC board opposite the module. This plane is essential for creating a low impedance return for ground and consistent stripline performance.

Use care in routing the RF trace between the module and the antenna or connector. Keep the trace as short as possible. Do not pass under the module or any other component. Do not route the antenna trace on multiple PCB layers as vias will add inductance. Vias are acceptable for tying together ground layers and component grounds and should be used in multiples.

Each of the module's ground pins should have short traces tying immediately to the ground plane through a via.

Bypass caps should be low ESR ceramic types and located directly adjacent to the pin they are serving.

A 50-ohm coax should be used for connection to an external antenna. A 50-ohm transmission line, such as a microstrip, stripline or coplanar waveguide should be used for routing RF on the PCB. The Microstrip Details section provides additional information.

In some instances, a designer may wish to encapsulate or "pot" the product. There is a wide variety of potting compounds with varying dielectric properties. Since such compounds can considerably impact RF performance and the ability to rework or service the product, it is the responsibility of the designer to evaluate and qualify the impact and suitability of such materials.

Pad Layout

The pad layout diagram in Figure 31 is designed to facilitate both hand and automated assembly.

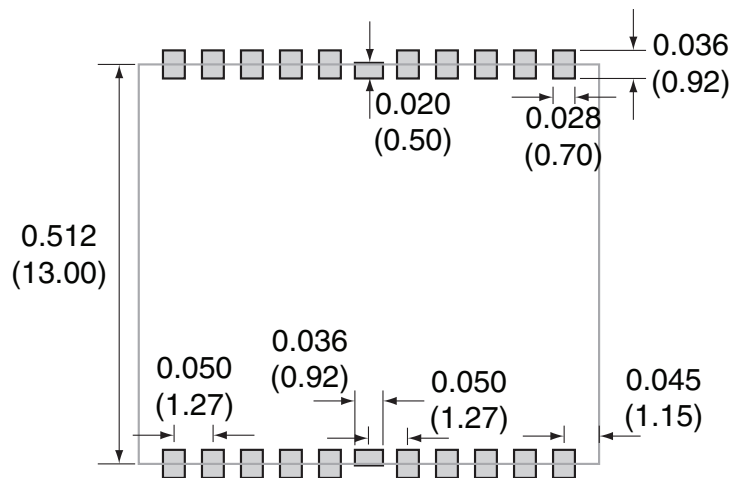
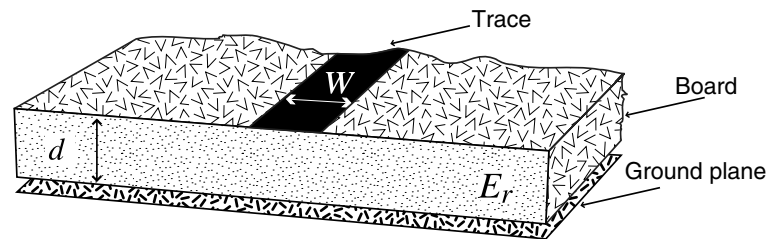

Figure 31: Recommended PCB Layout

Microstrip Details

A transmission line is a medium whereby RF energy is transferred from one place to another with minimal loss. This is a critical factor, especially in high-frequency products like Linx RF modules, because the trace leading to the module's antenna can effectively contribute to the length of the antenna, changing its resonant bandwidth. In order to minimize loss and detuning, some form of transmission line between the antenna and the module should be used, unless the antenna can be placed very close ($<1/8$ in) to the module. One common form of transmission line is a coax cable; another is the microstrip. This term refers to a PCB trace running over a ground plane that is designed to serve as a transmission line between the module and the antenna. The width is based on the desired characteristic impedance of the line, the thickness of the PCB, and the dielectric constant of the board material. For standard 0.062" thick FR-4 board material, the trace width would be 111 mils. The correct trace width can be calculated for other widths and materials using the information below. Handy software for calculating microstrip lines is also available on the Linx website, www.linxtechnologies.com.



$$E_e = \frac{E_r + 1}{2} + \frac{E_r - 1}{2} \cdot \frac{1}{\sqrt{1 + 12d/W}}$$

$$Z_0 = \begin{cases} \frac{60}{\sqrt{E_e}} \cdot \ln\left(\frac{8d}{W} + \frac{W}{4d}\right) & \text{For } \frac{W}{d} \leq 1 \\ \frac{120\pi}{\sqrt{E_e} \cdot \left(\frac{W}{d} + 1.393 + 0.667 \cdot \ln\left(\frac{W}{d} + 1.444\right)\right)} & \text{For } \frac{W}{d} \geq 1 \end{cases}$$

E_r = Dielectric constant of PCB material

Figure 32: Microstrip Formulas

Example Microstrip Calculations			
Dielectric Constant	Width/Height Ratio (W/d)	Effective Dielectric Constant	Characteristic Impedance (Ω)
4.80	1.8	3.59	50.0
4.00	2.0	3.07	51.0
2.55	3.0	2.12	48.0

Figure 33: Example Microstrip Calculations

Production Guidelines

The modules are housed in a hybrid SMD package that supports hand and automated assembly techniques. Since the modules contain discrete components internally, the assembly procedures are critical to ensuring the reliable function of the modules. The following procedures should be reviewed with and practiced by all assembly personnel.

Hand Assembly

Pads located on the bottom of the module are the primary mounting surface. Since these pads are inaccessible during mounting, castellations that run up the side of the module have been provided to facilitate solder wicking to the module's underside. This allows for very quick hand soldering for prototyping and small volume production.

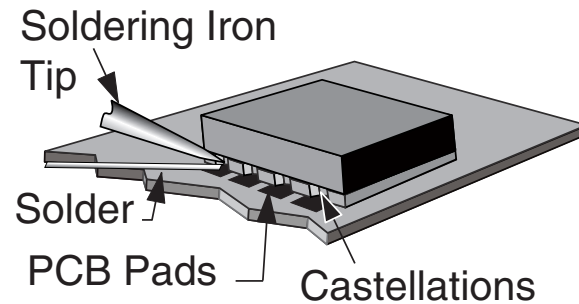

Figure 34: Soldering Technique

If the recommended pad guidelines have been followed, the pads will protrude slightly past the edge of the module. Use a fine soldering tip to heat the board pad and the castellation, then introduce solder to the pad at the module's edge. The solder will wick underneath the module, providing reliable attachment. Tack one module corner first and then work around the device, taking care not to exceed the times listed below.

Warning: Pay attention to the absolute maximum solder times.

Absolute Maximum Solder Times
Hand Solder Temperature TX: +225°C for 10 seconds
Hand Solder Temperature RX: +225°C for 10 seconds
Recommended Solder Melting Point: +180°C
Reflow Oven: +240°C Max. (See Figure 36)

Figure 35: Absolute Maximum Solder Times

Automated Assembly

For high-volume assembly, most users will want to auto-place the modules. The modules have been designed to maintain compatibility with reflow processing techniques; however, due to their hybrid nature, certain aspects of the assembly process are far more critical than for other component types.

Following are brief discussions of the three primary areas where caution must be observed.

Reflow Temperature Profile

The single most critical stage in the automated assembly process is the reflow stage. The reflow profile below should not be exceeded, since excessive temperatures or transport times during reflow will irreparably damage the modules. Assembly personnel will need to pay careful attention to the oven's profile to ensure that it meets the requirements necessary to successfully reflow all components while still remaining within the limits mandated by the modules. Figure 36 shows the recommended reflow oven profile for the modules.

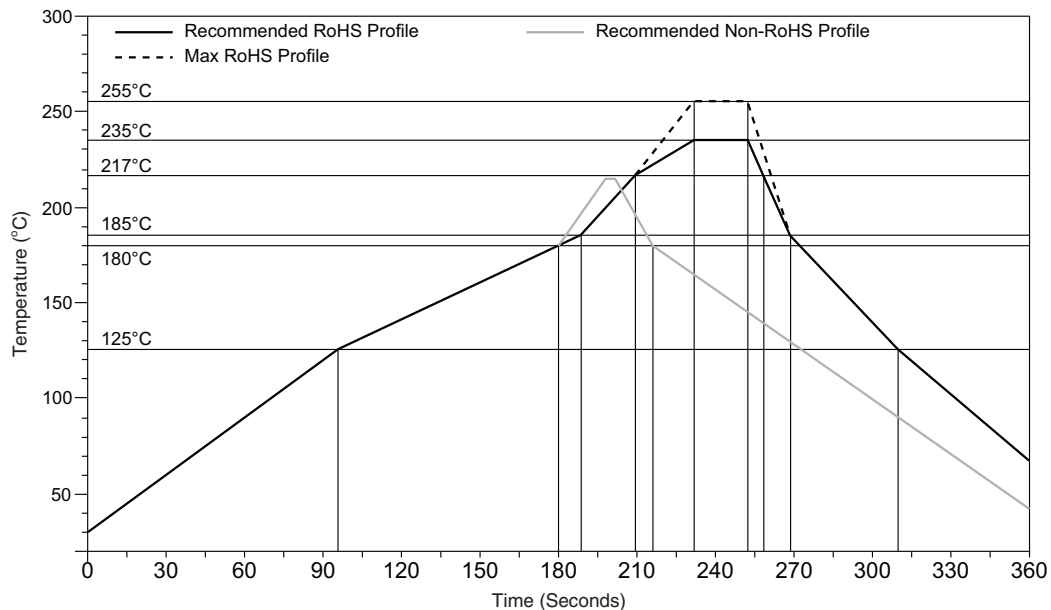

Figure 36: Maximum Reflow Profile

Shock During Reflow Transport

Since some internal module components may reflow along with the components placed on the board being assembled, it is imperative that the modules not be subjected to shock or vibration during the time solder is liquid. Should a shock be applied, some internal components could be lifted from their pads, causing the module to not function properly.

Washability

The modules are wash resistant, but are not hermetically sealed. Linx recommends wash-free manufacturing; however, the modules can be subjected to a wash cycle provided that a drying time is allowed prior to applying electrical power to the modules. The drying time should be sufficient to allow any moisture that may have migrated into the module to evaporate, thus eliminating the potential for shorting damage during power-up or testing. If the wash contains contaminants, the performance may be adversely affected, even after drying.

Resources

Support

For technical support, product documentation, application notes, regulatory guidelines and software updates, visit www.linxtechnologies.com

RF Design Services

For customers who need help implementing Linx modules, Linx offers design services including board layout assistance, programming, certification advice and packaging design. For more complex RF solutions, Apex Wireless, a division of Linx Technologies, creates optimized designs with RF components and firmware selected for the customer's application. Call +1 800 736 6677 (+1 541 471 6256 if outside the United States) for more information.

Antenna Factor Antennas

Linx's Antenna Factor division has the industry's broadest selection of antennas for a wide variety of applications.

For customers with specialized needs, custom antennas and design services are available along with simulations of antenna performance to speed development. Learn more at www.linxtechnologies.com.

AntennaFactor
by **Linx**



Linx Technologies
159 Ort Lane
Merlin, OR, US 97532

3090 Sterling Circle Suite 200
Boulder, CO 80301

Phone: +1 541 471 6256

Fax: +1 541 471 6251

www.linxtechnologies.com

Disclaimer

Linx Technologies is continually striving to improve the quality and function of its products. For this reason, we reserve the right to make changes to our products without notice. The information contained in this Data Guide is believed to be accurate as of the time of publication. Specifications are based on representative lot samples. Values may vary from lot-to-lot and are not guaranteed. "Typical" parameters can and do vary over lots and application. Linx Technologies makes no guarantee, warranty, or representation regarding the suitability of any product for use in any specific application. It is the customer's responsibility to verify the suitability of the part for the intended application. **NO LINX PRODUCT IS INTENDED FOR USE IN ANY APPLICATION WHERE THE SAFETY OF LIFE OR PROPERTY IS AT RISK.**

Linx Technologies **DISCLAIMS ALL WARRANTIES OF MERCHANTABILITY AND FITNESS FOR A PARTICULAR PURPOSE. IN NO EVENT SHALL LINX TECHNOLOGIES BE LIABLE FOR ANY OF CUSTOMER'S INCIDENTAL OR CONSEQUENTIAL DAMAGES ARISING IN ANY WAY FROM ANY DEFECTIVE OR NON-CONFORMING PRODUCTS OR FOR ANY OTHER BREACH OF CONTRACT BY LINX TECHNOLOGIES.** The limitations on Linx Technologies' liability are applicable to any and all claims or theories of recovery asserted by Customer, including, without limitation, breach of contract, breach of warranty, strict liability, or negligence. Customer assumes all liability (including, without limitation, liability for injury to person or property, economic loss, or business interruption) for all claims, including claims from third parties, arising from the use of the Products. The Customer will indemnify, defend, protect, and hold harmless Linx Technologies and its officers, employees, subsidiaries, affiliates, distributors, and representatives from and against all claims, damages, actions, suits, proceedings, demands, assessments, adjustments, costs, and expenses incurred by Linx Technologies as a result of or arising from any Products sold by Linx Technologies to Customer. Under no conditions will Linx Technologies be responsible for losses arising from the use or failure of the device in any application, other than the repair, replacement, or refund limited to the original product purchase price. Devices described in this publication may contain proprietary, patented, or copyrighted techniques, components, or materials. Under no circumstances shall any user be conveyed any license or right to the use or ownership of such items.

All rights reserved. ©2013 Linx Technologies

The stylized Linx logo, Wireless Made Simple, CipherLinx and the stylized CL logo are trademarks of Linx Technologies.