

DB101S-G Thru. DB107S-G

Reverse Voltage: 50 to 1000V

Forward Current: 1.0A

RoHS Device

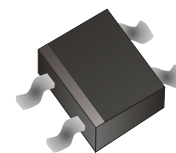

Features

- Rating to 1000V PRV
- Ideal for printed circuit board
- Low forward voltage drop,high current capability
- Reliable low cost construction utilizing molded plastic technique results in inexpensive product
- Lead tin Pb/Sn copper
- The plastic material has UL flammability classification 94V-0

Mechanical Data

- Polarit:As marked on Body
- Weight: 0.51 grams
- Mounting position:Any

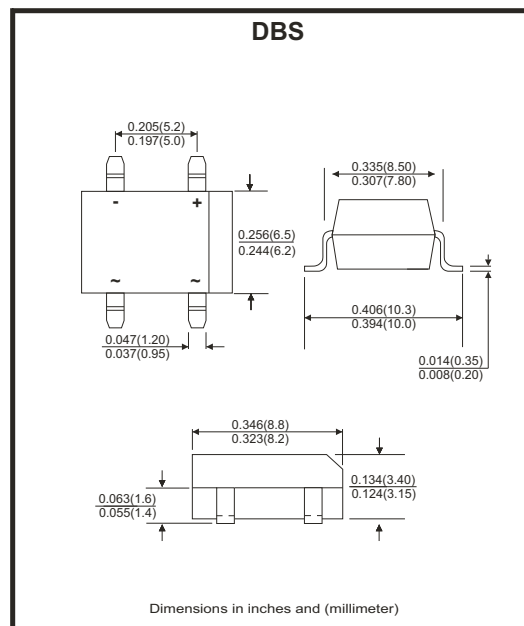

Maximum ratings and electrical characteristics

Rating at 25°C ambient temperature unless otherwise specified.
Single phase, half wave ,60Hz, resistive or inductive load.
For capacitive load, derate current by 20%

Parameter	Symbol	DB 101S-G	DB 102S-G	DB 103S-G	DB 104S-G	DB 105S-G	DB 106S-G	DB 107S-G	Unit
Maximum Reverse Peak Repetitive Voltage	V_{RRM}	50	100	200	400	600	800	1000	V
Maximum RMS Voltage	V_{RMS}	35	70	140	280	420	560	700	V
Maximum DC Blocking Voltage	V_{DC}	50	100	200	400	600	800	1000	V
Maximum Average Forward Rectified Current @ $T_A=40^\circ C$	$I_{(AV)}$	1.0							A
Peak Forward Surge Current , 8.3ms Single Half Sine-Wave Super Imposed On Rated Load	I_{FSM}	50							A
$I^2 t$ Rating For Fusing ($t < 8.3ms$)	$I^2 t$	10.4							$A^2 s$
Maximum Forward Voltage At 1.0A DC	V_F	1.1							V
Maximum Reverse Current @ $T_J=25^\circ C$ At rRated DC Blocking Voltage @ $T_J=125^\circ C$	I_R	10 500							μA
Typical Junction Capacitance (Note 1)	C_J	25							pF
Typical Thermal Resistance (Note 2)	$R_{\theta JA}$	40							$^\circ C/W$
Operating Temperature Range	T_J	-55 ~ +150							$^\circ C$
Storage Temperature Range	T_{STG}	-55 ~ +150							$^\circ C$

Notes:

1. Measured at 1.0MHz and applied reverse voltage of 4.0V.
2. Unit mounted on P.C.B with 0.51"x0.51" (13x13mm) copper pads.

Rating and Characteristics Curves (DB101S-G Thru. DB107S-G)

Fig.1 - Forward Current Derating Curve

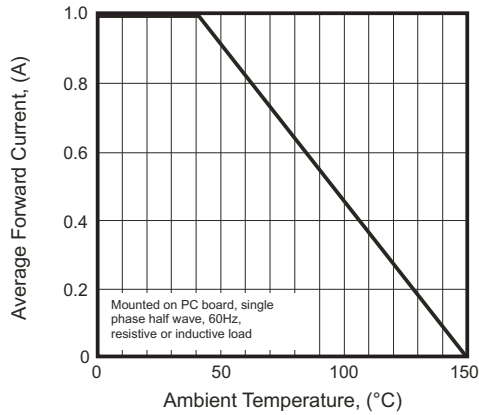

Fig.2 - Maximum Non-repetitive Surge Current

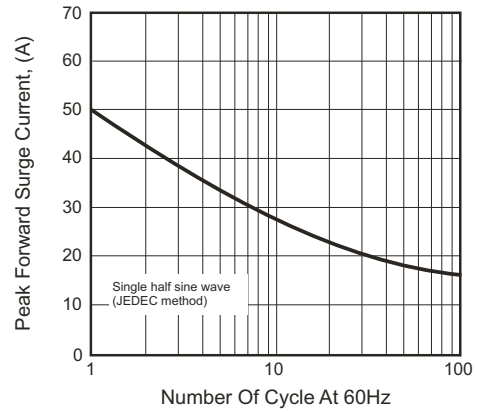

Fig.3 - Typical Junction Capacitance

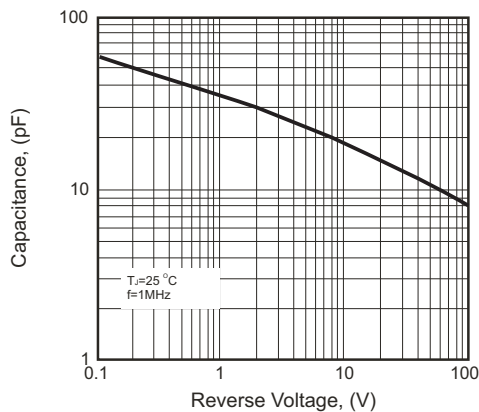

Fig.4 - Typical Forward Characteristics

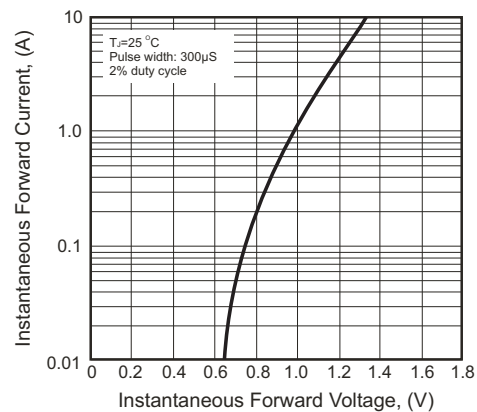
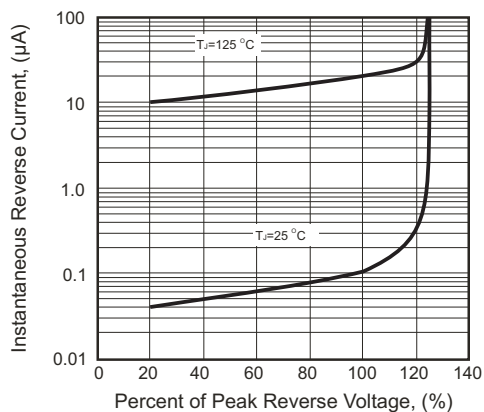
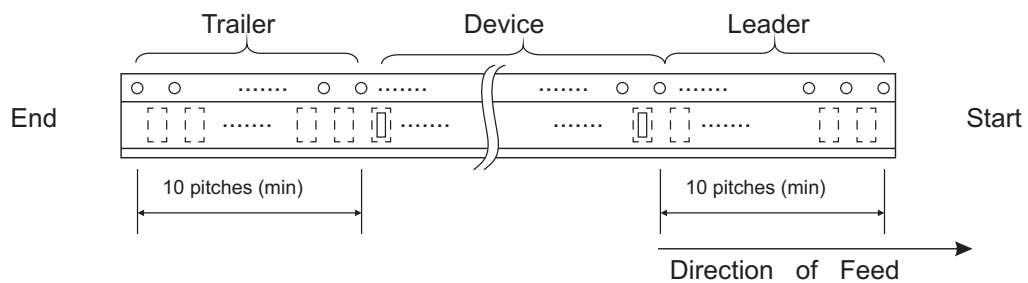
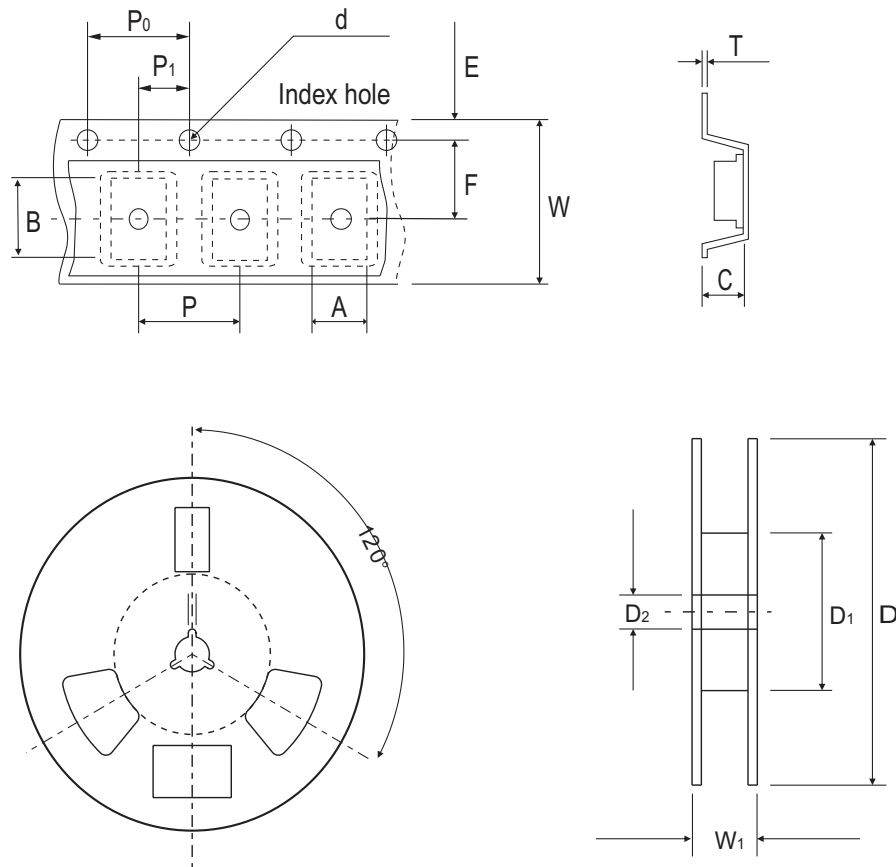

Fig.5 - Typical Reverse Characteristics



Reel Taping Specification



DBS	SYMBOL	A	B	C	d	D	D ₁	D ₂
	(mm)	8.64 ± 0.10	10.41 ± 0.10	3.81 ± 0.10	1.55 ± 0.05	330	50.0 MIN.	13.00 ± 0.20
	(inch)	0.340 ± 0.004	0.409 ± 0.004	0.150 ± 0.004	0.061 ± 0.002	13	1.969 MIN.	0.512 ± 0.008

DBS	SYMBOL	E	F	P	P ₀	P ₁	T	W	W ₁
	(mm)	1.75 ± 0.10	7.50 ± 0.05	12.00 ± 0.10	4.00 ± 0.10	2.00 ± 0.10	0.32	16.00 ± 0.30	16.00~18.40
	(inch)	0.069 ± 0.004	0.295 ± 0.002	0.472 ± 0.004	0.157 ± 0.004	0.079 ± 0.004	0.013	0.630 ± 0.012	0.630~0.724

Marking Code

Part Number	Marking code	Packaging
DB101SP-G	DB101S	Tube
DB102SP-G	DB102S	Tube
DB103SP-G	DB103S	Tube
DB104SP-G	DB104S	Tube
DB105SP-G	DB105S	Tube
DB106SP-G	DB106S	Tube
DB107SP-G	DB107S	Tube
DB101ST-G	DB101S	Reel
DB102ST-G	DB102S	Reel
DB103ST-G	DB103S	Reel
DB104ST-G	DB104S	Reel
DB105ST-G	DB105S	Reel
DB106ST-G	DB106S	Reel
DB107ST-G	DB107S	Reel

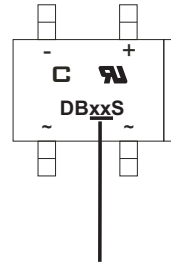

XX / XXX = Product type marking code
C = Comchip Logo

Note:

1) Suffix code after part number to specify packaging item .

Packaging	Code
TUBE PACK	P
REEL PACK	T

Standard Packaging

Case Type	TUBE PACK	
	TUBE (pcs)	BOX (pcs)
DBS	50	5,000

Case Type	REEL PACK	
	REEL (pcs)	Reel Size (inch)
DBS	1,000	13