



MAX3160/MAX3161/MAX3162

+3.0V to +5.5V, 1µA, RS-232/RS-485/422 Multiprotocol Transceivers

General Description

The MAX3160/MAX3161/MAX3162 are programmable RS-232/RS-485/422 multiprotocol transceivers. The MAX3160/MAX3161 are pin programmable as a 2TX/2RX RS-232 interface or a single RS-485/422 transceiver. The MAX3162 is configured as a 2TX/2RX RS-232 interface and a single RS-485/422 transceiver simultaneously.

All devices incorporate a proprietary low-dropout transmitter output stage and an on-board dual charge pump to allow RS-232 and RS-485/422 compliant performance from a +3V to +5.5V supply. The receivers feature true fail-safe circuitry that guarantees a logic-high receiver output when the receiver inputs are open or shorted. These devices also feature pin-selectable transmitter slew rates for both RS-232 and RS-485/422 modes. Slew-rate limiting minimizes EMI and reduces reflections caused by improperly terminated cables, allowing error-free data transmission up to 250kbps. Disabling slew-rate limiting allows these devices to transmit at data rates up to 10Mbps in RS-485/422 mode and up to 1Mbps in RS-232 mode. The MAX3160/MAX3161/MAX3162 feature a 1µA shutdown mode, and short-circuit limiting and thermal shutdown circuitry to protect against excessive power dissipation.

The MAX3160/MAX3162 offer a flow-through pinout that facilitates board layout. The MAX3160/MAX3161/MAX3162 are available in tiny SSOP packages and operate over the commercial and extended temperature ranges.

Applications

Point-of-Sales Equipment Peripherals
Industrial Controls Networking
RS-232 to RS-485
Interface Converters

Ordering Information

PART	TEMP RANGE	PIN-PACKAGE
MAX3160CAP+	0°C to +70°C	20 SSOP
MAX3160EAP+	-40°C to +85°C	20 SSOP
MAX3161CAG+	0°C to +70°C	24 SSOP
MAX3161EAG+	-40°C to +85°C	24 SSOP
MAX3162CAI+	0°C to +70°C	28 SSOP
MAX3162EAI+	-40°C to +85°C	28 SSOP

+Denotes a lead(Pb)-free/RoHS-compliant package.

Pin Configurations appear at end of data sheet.

Selector Guide appears at end of data sheet.

Features

- ◆ Single-Supply Operation from +3V to +5.5V
- ◆ Pin-Programmable as 2TX/2RX RS-232 or Single RS-485/422 (MAX3160/MAX3161)
- ◆ 2TX/2RX RS-232 and Single RS-485/422 (MAX3162)
- ◆ Pin-Programmable RS-232/RS-485 Transmitter Slew Rates Reduce EMI
- ◆ 10Mbps RS-485 and 1Mbps RS-232 Data Rates
- ◆ Pin-Programmable Half-Duplex or Full-Duplex RS-485/422 Operation (MAX3160/MAX3161)
- ◆ RS-485/422 True Fail-Safe Receivers
- ◆ Transmitters and Receivers Protected Against Wiring Faults
- ◆ 1µA Shutdown Supply Current
- ◆ 1/8-Unit Load Allows up to 256 Transceivers on the Bus

Typical Operating Circuit

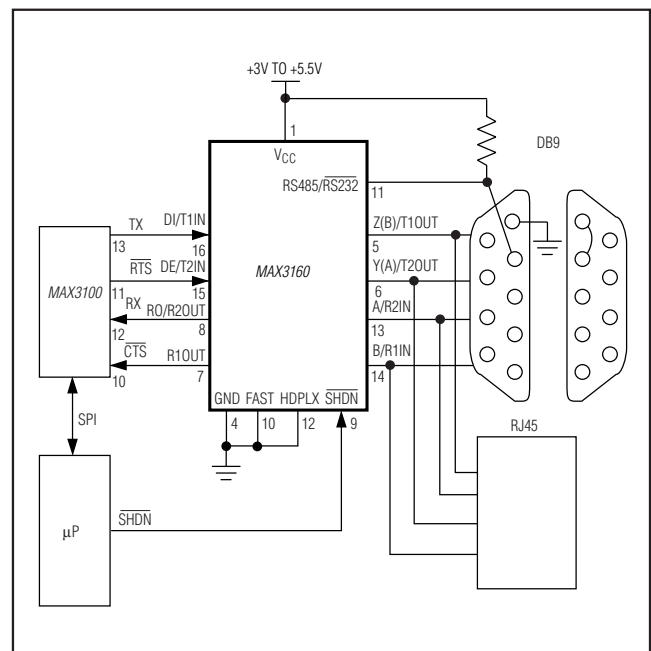

For pricing, delivery, and ordering information, please contact Maxim Direct at 1-888-629-4642, or visit Maxim's website at www.maximintegrated.com.

MAX3160/MAX3161/MAX3162

+3.0V to +5.5V, 1µA, RS-232/RS-485/422 Multiprotocol Transceivers

ABSOLUTE MAXIMUM RATINGS

V _{CC} to GND-0.3V to +6V	Continuous Power Dissipation (T _A = +70°C)
V ₊ to GND-0.3V to +7V	20-Pin SSOP (derate 11.9W/°C above +70°C)952mW
V ₋ to GND0.3V to -7V	24-Pin SSOP (derate 14.9W/°C above +70°C)1195mW
V ₊ - V ₋ (Note 1)+13V	28-Pin SSOP (derate 15W/°C above +70°C)1201mW
Input Voltages		Operating Temperature Ranges
T1IN, T2IN, DI, DE485, <u>RE485</u> , TE232, <u>RE232</u> , <u>SHDN</u> ,		MAX316_CA_0°C to +70°C
FAST, HDPLX, RS485/ <u>RS232</u> to GND-0.3V to +6V	MAX316_EA_-40°C to +85°C
A, B, R1IN, R2IN to GND±25V	Storage Temperature Range-65°C to +150°C
Output Voltages		Junction Temperature+150°C
T1OUT, T2OUT, Y, Z to GND±13.2V	Lead Temperature (soldering, 10s)+300°C
R2OUT, R1OUT, RO to GND-0.3V to (V _{CC} + 0.3V)	
Output Short-Circuit Duration		
T1OUT, T2OUT, Y, ZContinuous	

Note 1: V₊ and V₋ can have maximum magnitudes of 7V, but their absolute difference cannot exceed 13V.

Stresses beyond those listed under "Absolute Maximum Ratings" may cause permanent damage to the device. These are stress ratings only, and functional operation of the device at these or any other conditions beyond those indicated in the operational sections of the specifications is not implied. Exposure to absolute maximum rating conditions for extended periods may affect device reliability.

ELECTRICAL CHARACTERISTICS

(V_{CC} = +3V to +5.5V, C1–C4 = 0.1µF when tested at +3.3V ±10%; C1 = 0.047µF and C2, C3, C4 = 0.33µF when tested at +5V ±10%; T_A = T_{MIN} to T_{MAX}, unless otherwise noted. Typical values are at T_A = +25°C.)

PARAMETER	SYMBOL	CONDITIONS	MIN	TYP	MAX	UNITS
DC CHARACTERISTICS						
V _{CC} Standby Current	I _{CC}	MAX3160/MAX3161, no load, RS485/RS232 = GND		1.2	2.5	mA
		MAX3160/MAX3161, no load, RS485/RS232 = V _{CC}		2.5	5.5	
		MAX3162 No Load		3.0	6	
V _{CC} Shutdown Current	I _{CC}	<u>SHDN</u> = GND, receiver inputs open or grounded		1	10	µA
TRANSMITTER AND LOGIC INPUTS (DI, T1IN, T2IN, DE485, <u>RE485</u>, TE232, <u>RE232</u>, FAST, HDPLX, <u>SHDN</u>, RS485/<u>RS232</u>)						
Logic Input Low	V _{IL}				0.8	V
Logic Input High	V _{IH}	V _{CC} = +3.3V	2.0			V
		V _{CC} = +5V	2.4			
Logic Input Leakage Current	I _{INL}			±0.01	±1	µA
Transmitter Logic Hysteresis	V _{HYS}			0.5		V
RS-232 AND RS-485/422 RECEIVER OUTPUTS (R1OUT, R2OUT, RO)						
Receiver Output Voltage Low	V _{OL}	I _{OUT} = 2.5mA			0.4	V
Receiver Output Voltage High	V _{OH}	I _{OUT} = -1.5mA	V _{CC} - 0.6			V
Receiver Output Short Circuit Current	I _{OSR}	0 < V _O < V _{CC}		±20	±60	mA
Receiver Output Leakage Current	I _{OZR}	Receivers disabled		±0.05	±1	µA

MAX3160/MAX3161/MAX3162

+3.0V to +5.5V, 1μA, RS-232/RS-485/422 Multiprotocol Transceivers

ELECTRICAL CHARACTERISTICS (continued)

(V_{CC} = +3V to +5.5V, C1–C4 = 0.1μF when tested at +3.3V ±10%; C1 = 0.047μF and C2, C3, C4 = 0.33μF when tested at +5V ±10%; T_A = T_{MIN} to T_{MAX}, unless otherwise noted. Typical values are at T_A = +25°C.)

PARAMETER	SYMBOL	CONDITIONS	MIN	TYP	MAX	UNITS
RS-232 RECEIVER INPUTS (R1IN, R2IN)						
Input Voltage Range			-25		25	V
Input Threshold Low		V _{CC} = +3.3V	0.6			V
		V _{CC} = +5V	0.8			
Input Threshold High		V _{CC} = +3.3V			2.0	V
		V _{CC} = +5V			2.4	
Input Hysteresis				0.5		V
Input Resistance			3	5	7	kΩ
RS-485/422 RECEIVER INPUTS (NOTE 2)						
Input Resistance	R _{IN}	-7V < V _{CM} < +12V	MAX3160	48		kΩ
			MAX3161/ MAX3162	96		
Input Current	I _{IN}	MAX3160	V _{CM} = +12V		0.25	mA
			V _{CM} = -7V		-0.15	
		MAX3161/MAX3162	V _{CM} = +12V		0.125	
			V _{CM} = -7V		-0.075	
Input Differential Threshold	V _{TH}		-200		-50	mV
Input Hysteresis	ΔV _{TH}			30		mV
RS-232 TRANSMITTER OUTPUTS (T1OUT, T2OUT)						
Output Voltage Swing		Both transmitter outputs loaded with 3kΩ to GND	±5	±5.4		V
Output Resistance		V _{CC} = V ₊ = V ₋ = 0V, V _{T1OUT} = V _{T2OUT} = +2V	300	10M		Ω
Output Short-Circuit Current		T _{OUT} = GND		±30	±60	mA
Output Leakage Current		V _{OUT} = ±12V TE232 = GND or $\overline{\text{SHDN}}$ = GND	MAX3160/ MAX3161		±125	μA
			MAX3162		±25	
RS-485/422 TRANSMITTER OUTPUTS (Y, Z)						
Differential Output Voltage	V _{OD}	Figure 1	R = 27Ω (RS-485)	1.5		V
			R = 50Ω (RS-422)	2		
Change in Magnitude of Differential Output Voltage for Complementary Output States	ΔV _{OD}	R = 27Ω or 50Ω, Figure 1	-0.2		0.2	V
Common Mode Output Voltage	V _{OC}	R = 27Ω or 50Ω, Figure 1			3	V
Change in Magnitude of Common Mode Output Voltage for Complementary Output States	ΔV _{OC}	R = 27Ω or 50Ω, Figure 1			0.2	V

MAX3160/MAX3161/MAX3162

+3.0V to +5.5V, 1µA, RS-232/RS-485/422 Multiprotocol Transceivers

ELECTRICAL CHARACTERISTICS (continued)

(V_{CC} = +3V to +5.5V, C₁–C₄ = 0.1µF when tested at +3.3V ±10%; C₁ = 0.047µF and C₂, C₃, C₄ = 0.33µF when tested at +5V ±10%; T_A = T_{MIN} to T_{MAX}, unless otherwise noted. Typical values are at T_A = +25°C.)

PARAMETER	SYMBOL	CONDITIONS	MIN	TYP	MAX	UNITS	
Output Short-Circuit Current	I _{SC}	V _Y or V _Z = +12V to -7V			±250	mA	
Output Leakage Current	I _O	V _Y or V _Z = +12V, DE485 = GND or SHDN = GND	MAX3160/ MAX3161		±125	µA	
			MAX3162		±25		
RS-232 TIMING CHARACTERISTICS (FAST = GND, 250kbps, ONE TRANSMITTER SWITCHING)							
Maximum Data Rate		R _L = 3kΩ, C _L = 1000pF	250			kbps	
Receiver Propagation Delay		R _{IN} to R _{OUT} , C _L = 150pF	0.15			µs	
Receiver Output Enable Time			200			ns	
Receiver Output Disable Time			200			ns	
Transmitter Skew		t _{PHL} - t _{PLH}	100			ns	
Receiver Skew		t _{PLH} - t _{PHL}	50			ns	
Transition-Region Slew Rate		V _{CC} = +3.3V, T _A = +25°C, R _L = 3kΩ to 7kΩ, measured from +3.0V or -3.0V to +3.0V	C _L = 150pF to 1000pF		6	30	V/µs
			C _L = 150pF to 2500pF		4	30	
RS-232 TIMING CHARACTERISTICS (FAST = V_{CC}, 1Mbps, ONE TRANSMITTER SWITCHING)							
Maximum Data Rate		V _{CC} = +3V to +4.5V, R _L = 3kΩ, C _L = 250pF	1			Mbps	
			V _{CC} = +4.5V to +5.5V, R _L = 3kΩ, C _L = 1000pF		1		
Receiver Propagation Delay		R _{IN} to R _{OUT} , C _L = 150pF	0.15			µs	
Receiver Output Enable Time			200			ns	
Receiver Output Disable Time			200			ns	
Transmitter Skew		t _{PHL} - t _{PLH}	25			ns	
Receiver Skew		t _{PLH} - t _{PHL}	50			ns	
Transition-Region Slew Rate		V _{CC} = +3.3V, T _A = +25°C, R _L = 3kΩ to 7kΩ, C _L = 150pF to 1000pF, measured from +3.0V or -3.0V to +3.0V	24		150	V/µs	
RS-485/422 TIMING CHARACTERISTICS (FAST = GND) 250kbps							
Driver Propagation Delay	t _{DPHL} , t _{DPLH}	R _{DIFF} = 54Ω, C _L = 50pF, Figures 3, 5	200	400	800	ns	
Driver Rise and Fall Time	t _{DPHL} , t _{DPLH}	R _{DIFF} = 54Ω, C _L = 50pF, Figures 3, 5	200	400	800	ns	
Driver Propagation Delay Skew	t _{DSKEW}	R _{DIFF} = 54Ω, C _L = 50pF, Figure 3, 5			200	ns	
Driver Output Enable Time	t _{DZH} , t _{RZL}	R _{DIFF} = 54Ω, C _L = 50pF, Figures 4, 6	400		800	ns	
Driver Output Disable Time	t _{DLZ} , t _{DHZ}	R _{DIFF} = 54Ω, C _L = 50pF, Figure 4, 6	200		400	ns	
Receiver Propagation Delay	t _{RPLH} , t _{RPHL}	C _L = 15pF, Figures 7, 9	25	80	150	ns	
Receiver Propagation Delay Skew	t _{RSKEW}	C _L = 50pF, Figures 7, 9			10	ns	

MAX3160/MAX3161/MAX3162

+3.0V to +5.5V, 1 μ A, RS-232/RS-485/422 Multiprotocol Transceivers

ELECTRICAL CHARACTERISTICS (continued)

(V_{CC} = +3V to +5.5V, C1–C4 = 0.1 μ F when tested at +3.3V \pm 10%; C1 = 0.047 μ F and C2, C3, C4 = 0.33 μ F when tested at +5V \pm 10%; T_A = T_{MIN} to T_{MAX} , unless otherwise noted. Typical values are at T_A = +25°C.)

PARAMETER	SYMBOL	CONDITIONS	MIN	TYP	MAX	UNITS
Receiver Output Enable Time	t_{RZL} , t_{RZH}	C_L = 50pF, Figures 2, 8		100		ns
Receiver Output Disable Time	t_{RLZ} , t_{RHZ}	C_L = 50pF, Figures 2, 8		100		ns
RS-485/RS-422 TIMING CHARACTERISTICS (FAST = V_{CC}, 10Mbps)						
Driver Propagation Delay	t_{DPHL} , t_{DPLH}	R_{DIFF} = 54 Ω , C_L = 50pF, Figures 3, 5		60	120	ns
Driver Rise And Fall Times	t_{DR} , t_{DF}	R_{DIFF} = 54 Ω , C_L = 50pF, Figures 3, 5		10	25	ns
Driver Propagation Delay Skew	t_{DSKEW}	R_{DIFF} = 54 Ω , C_L = 50pF, Figures 3, 5			10	ns
Driver Output Enable Time	t_{DZL}	R_{DIFF} = 54 Ω , C_L = 50pF, Figures 4, 6		400	800	ns
Driver Output Disable Time	t_{DLZ} , t_{DHZ}	R_{DIFF} = 54 Ω , C_L = 50pF, Figures 4, 6		200	400	ns
Receiver Propagation Delay	t_{RPLH} , t_{RPHL}	C_L = 15pF, Figures 7, 9		80	150	ns
Receiver Propagation Delay Skew	t_{RSKEW}	C_L = 50pF, Figures 7, 9			10	ns
Receiver Output Enable Time	t_{RZL} , t_{RZH}	C_L = 50pF, Figures 2, 8		100		ns
Receiver Output Disable Time	t_{RLZ} , t_{RHZ}	C_L = 15pF, Figures 2, 8		100		ns

Note 2: Applies to A, B for MAX3162 and MAX3160/MAX3161 with HDPLX = GND, or Y, Z for MAX3160/MAX3161 with HDPLX = V_{CC} .

Typical Operating Characteristics

(V_{CC} = +3.3V, 250kbps data rate, 0.1 μ F capacitors, all RS-232 transmitters (RS-232 mode) loaded with 3k Ω to ground, T_A = +25°C, unless otherwise noted.)

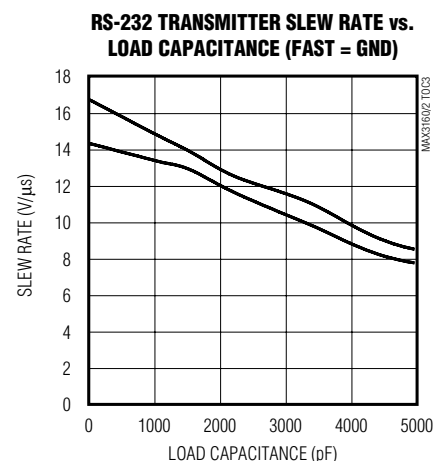
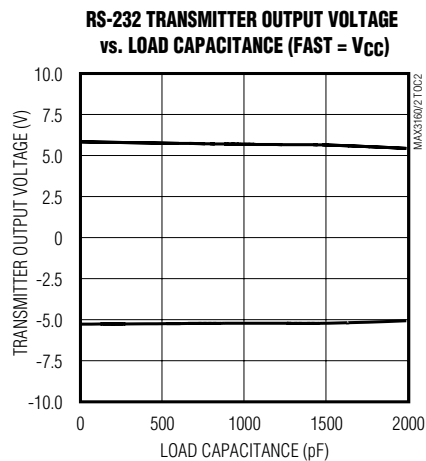
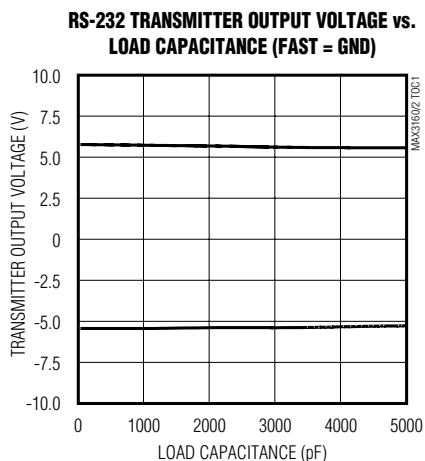

MAX3160/MAX3161/MAX3162

+3.0V to +5.5V, 1μA, RS-232/RS-485/422 Multiprotocol Transceivers

Typical Operating Characteristics (continued)

($V_{CC} = +3.3V$, 250kbps data rate, 0.1μF capacitors, all RS-232 transmitters (RS-232 mode) loaded with 3kΩ to ground, $T_A = +25^\circ C$, unless otherwise noted.)

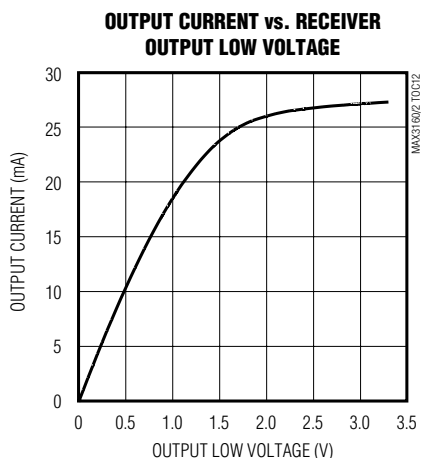
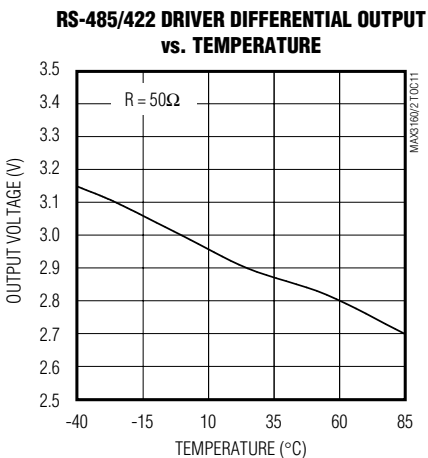
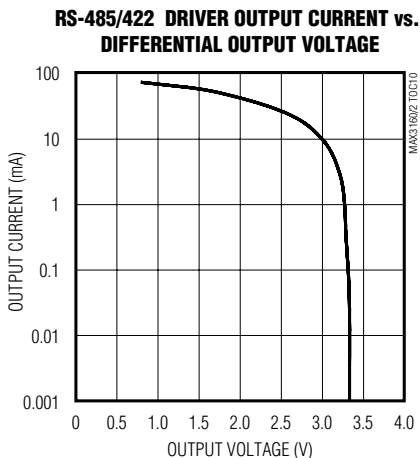
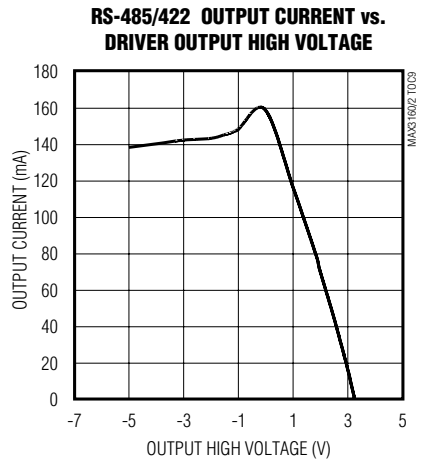
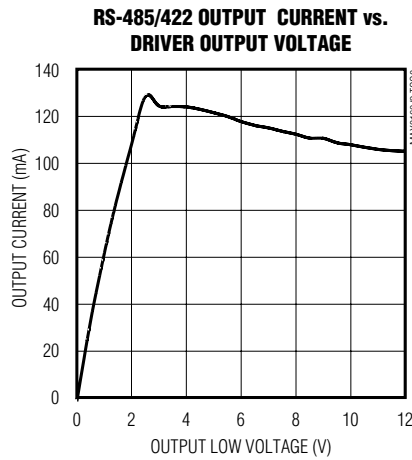
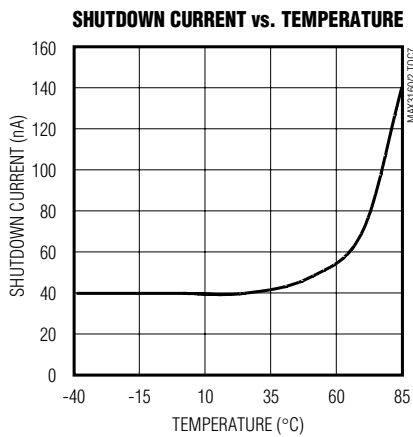
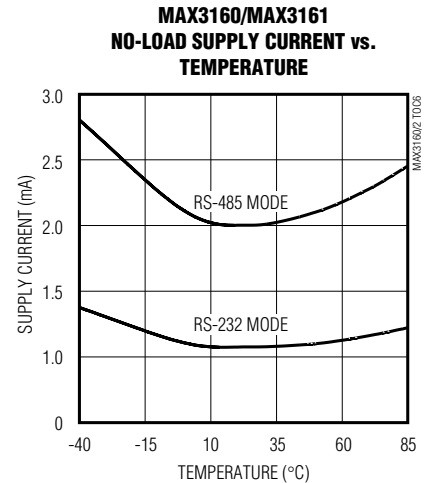
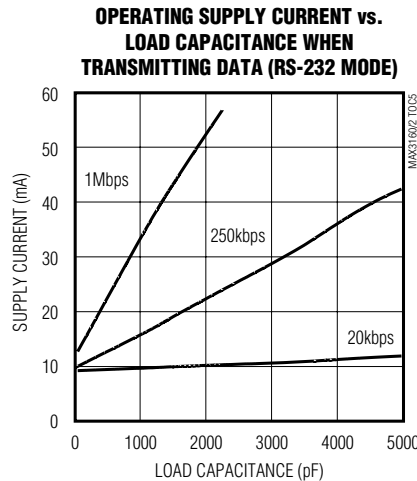
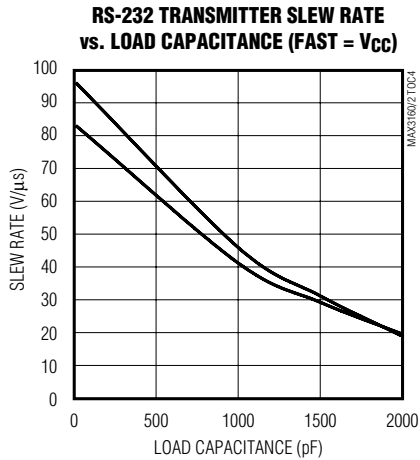

MAX3160/MAX3161/MAX3162

+3.0V to +5.5V, 1 μ A, RS-232/RS-485/422 Multiprotocol Transceivers

Typical Operating Characteristics (continued)

($V_{CC} = +3.3V$, 250kbps data rate, 0.1 μ F capacitors, all RS-232 transmitters (RS-232 mode) loaded with 3k Ω to ground, $T_A = +25^\circ C$, unless otherwise noted.)

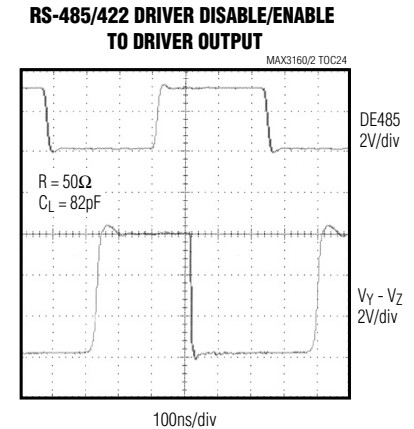
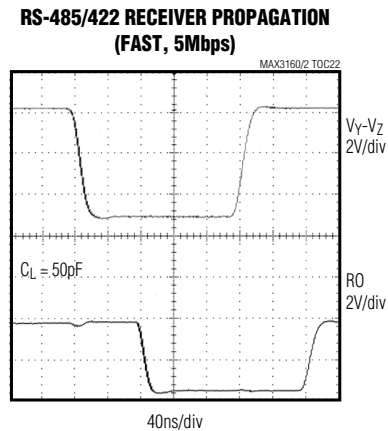
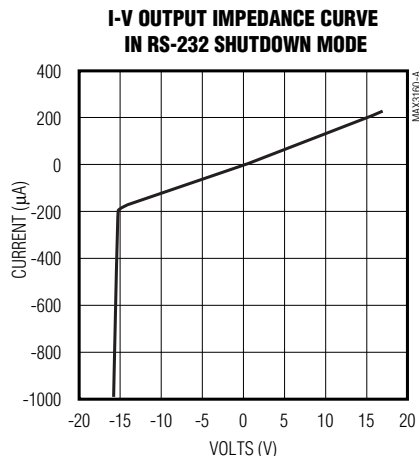
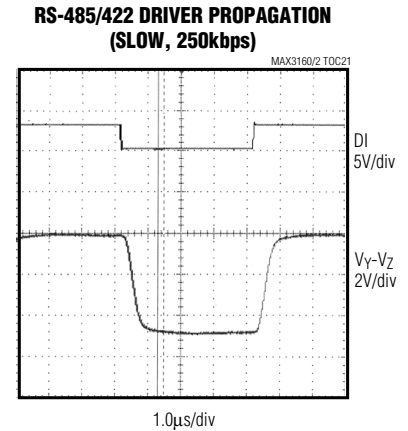
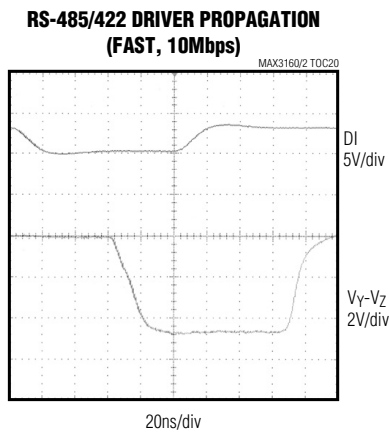
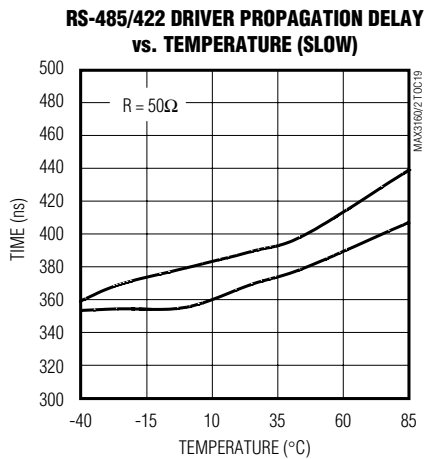
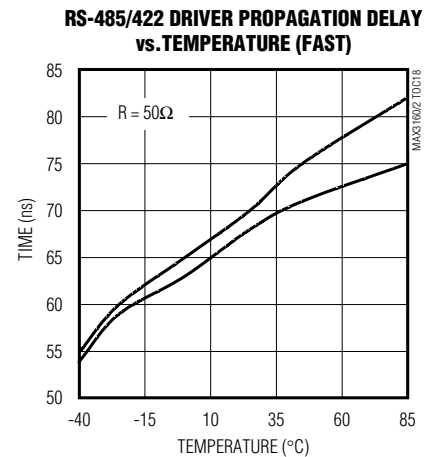
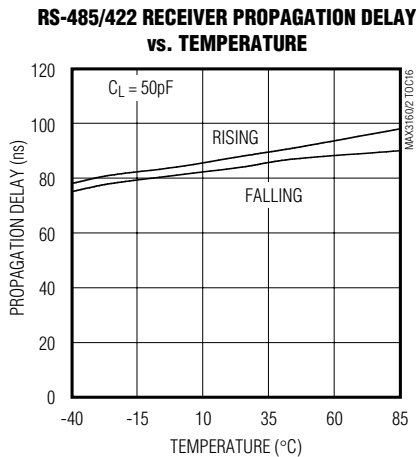
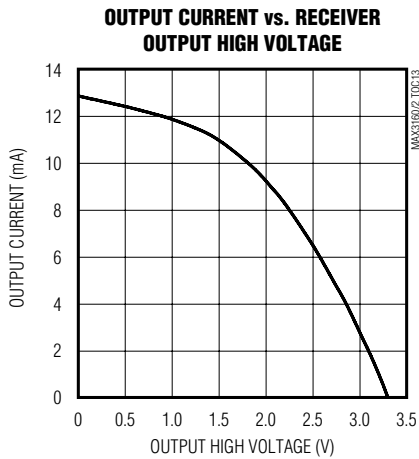

MAX3160/MAX3161/MAX3162

+3.0V to +5.5V, 1 μ A, RS-232/RS-485/422 Multiprotocol Transceivers

Pin Description

PIN			NAME	FUNCTION
MAX3160	MAX3161	MAX3162		
1	1	1	C1+	Positive Terminal of the Positive Flying Capacitor
2	2	2	V _{CC}	Positive Supply Voltage
3	3	3	C1-	Negative Terminal of the Positive Flying Capacitor
4	4	4	GND	Ground
—	5	5	T1OUT	RS-232 Driver Output
5	—	—	Z(B)/T1OUT	Inverting RS-485/422 Driver Output in Full-Duplex Mode (and Inverting RS-485/422 Receiver Input in Half-Duplex Mode)/RS-232 Driver Output
—	—	6	Z	Inverting RS-485/422 Driver Output
—	6	—	Z(B)	Inverting RS-485/422 Driver Output in Full-Duplex Mode (and Inverting RS-485/422 Receiver Input in Half-Duplex Mode)
6	—	—	Y(A)/T2OUT	Noninverting RS-485/422 Driver Output in Full-Duplex Mode (and Noninverting RS-485/422 Receiver Input in Half-Duplex Mode)/RS-232 Driver Output
—	—	7	Y	Noninverting RS-485/422 Driver Output
—	7	—	Y(A)	Noninverting RS-485/422 Driver Output in Full-Duplex Mode (and Noninverting RS-485/422 Receiver Input in Half-Duplex Mode)
7	9	9	R1OUT	RS-232 Receiver Output
—	8	8	T2OUT	RS-232 Driver Output
8	10	—	RO/R2OUT	RS-485/422 Receiver Output/RS-232 Receiver Output
9	11	13	$\overline{\text{SHDN}}$	Active-Low Shutdown-Control Input. Drive low to shut down transmitters and charge pump.
—	—	10	R2OUT	RS-232 Driver Output
10	12	14	FAST	Select slew rate limiting for both RS-232 and RS-485/422. Slew rate limits with a logic-level low.
—	—	11	RO	RS-485/422 Receiver Output
11	13	—	RS485/RS232	Software-Programmable Pin Functionality. Operates as RS-485/422 with a logic-level high; operates as RS-232 with a logic-level low.
—	—	12	$\overline{\text{RE485}}$	RS-485/422 Receiver Enable. Logic-level low enables RS-485/422 receivers.
12	14	—	HDPLX	Software-Programmable Pin Functionality. Operates in full-duplex mode when low; operates in half-duplex mode when high.

MAX3160/MAX3161/MAX3162

+3.0V to +5.5V, 1 μ A, RS-232/RS-485/422

Multiprotocol Transceivers

Pin Description (continued)

PIN			NAME	FUNCTION
MAX3160	MAX3161	MAX3162		
13	—	—	A/R2IN	Noninverting RS-485/422 Receiver Input/RS-232 Receiver Input
14	—	—	B/R1IN	Inverting RS-485/422 Receiver Input/RS-232 Receiver Input
—	—	15	$\overline{RE232}$	RS-232 Receiver Enable. Logic-level low enables RS-232 receivers.
—	15	17	A	Noninverting RS-485/422 Receiver Input
15	19	—	DE485/T2IN	RS-485/RS-422 Driver Enable/RS-232 Driver Input
—	—	16	TE232	RS-232 Transmitter Output Enable
—	16	18	B	Inverting RS-485/422 Receiver Input
16	20	—	DI/T1IN	RS-485/RS-422 Driver Input/RS-232 Driver Input
—	17	19	R2IN	RS-232 Receiver Input
17	21	25	V-	Negative Charge-Pump Rail
—	18	20	R1IN	RS-232 Receiver Input
18	22	26	C2-	Negative Terminal of the Negative Flying Capacitor
19	23	27	C2+	Positive Terminal of the Negative Flying Capacitor
20	24	28	V+	Positive Charge-Pump Rail
—	—	21	T2IN	RS-232 Driver Input
—	—	22	DE485	RS-485/RS-422 Driver Enable
—	—	23	DI	RS-485/RS-422 Driver Input
—	—	24	T1IN	RS-232 Driver Input

MAX3160/MAX3161/MAX3162

**+3.0V to +5.5V, 1 μ A, RS-232/RS-485/422
Multiprotocol Transceivers**

Functional Diagrams

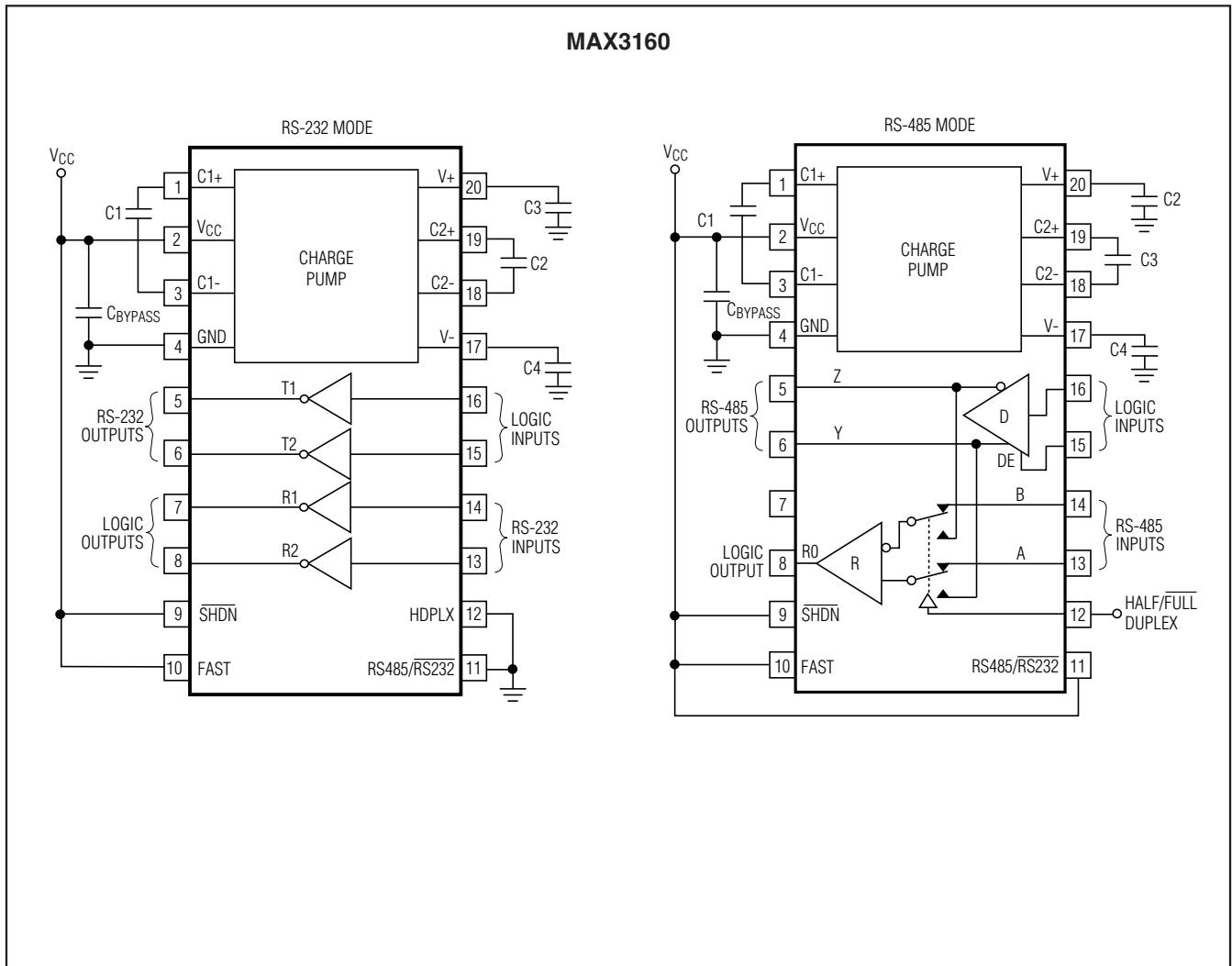

MAX3160/MAX3161/MAX3162

+3.0V to +5.5V, 1 μ A, RS-232/RS-485/422

Multiprotocol Transceivers

Functional Diagrams (continued)

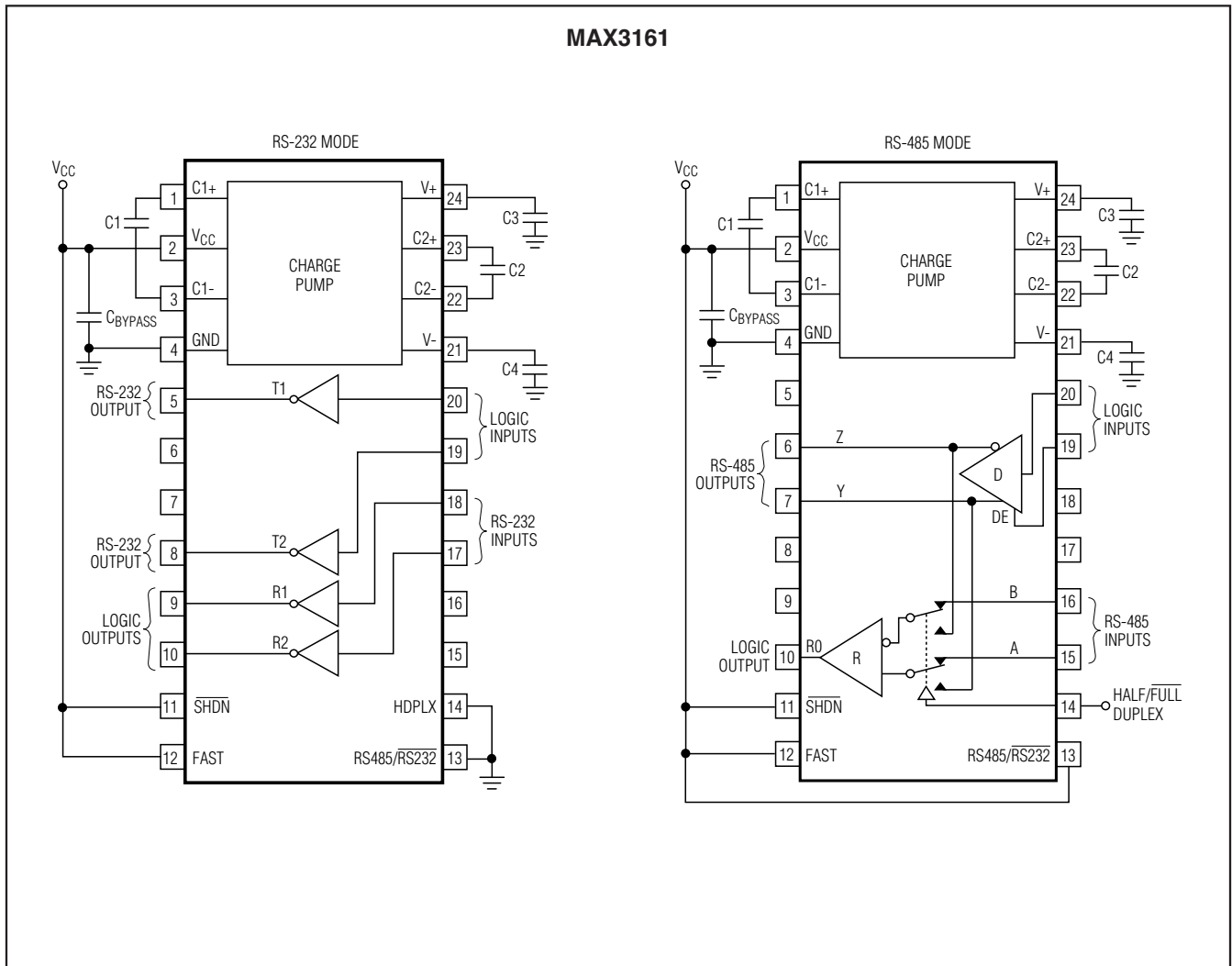

MAX3160/MAX3161/MAX3162

**+3.0V to +5.5V, 1 μ A, RS-232/RS-485/422
Multiprotocol Transceivers**

Functional Diagrams (continued)

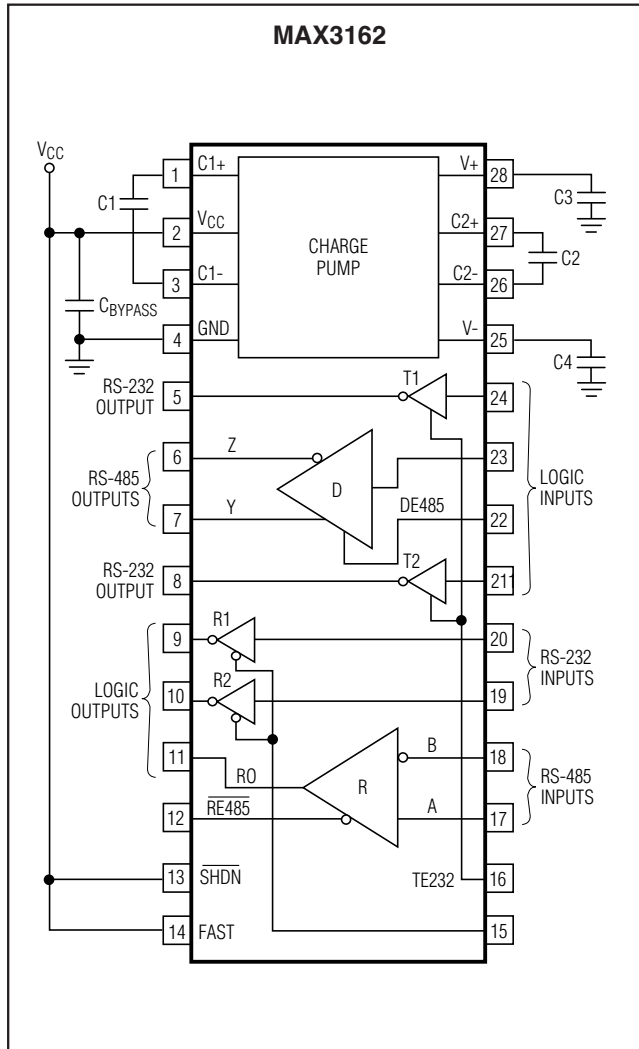

Test Circuits

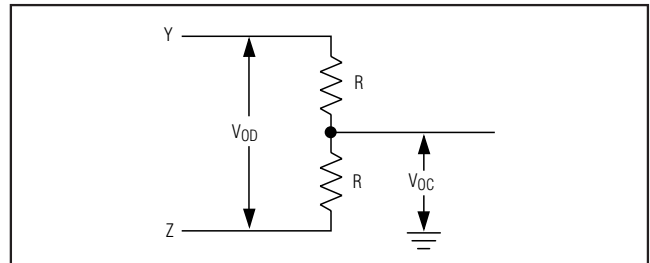

Figure 1. RS-485/422 Driver DC Test Load

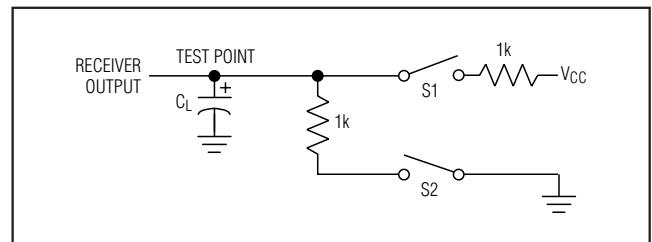

Figure 2. RS-485/422 Receiver Enable/Disable Timing Test Load

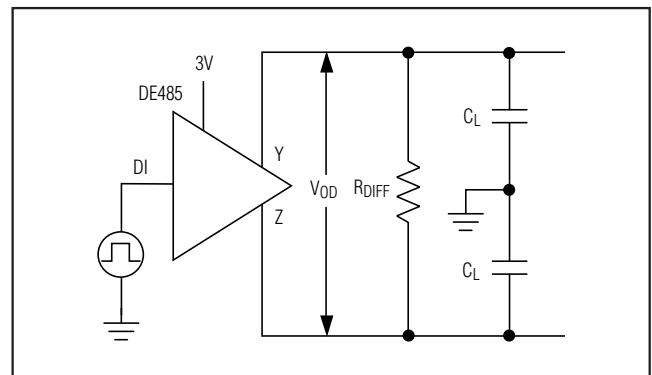

Figure 3. RS-485/422 Driver Timing Test Circuit

MAX3160/MAX3161/MAX3162

+3.0V to+5.5V, 1 μ A, RS-232/RS-485/422

Multiprotocol Transceivers

Test Circuits (continued)

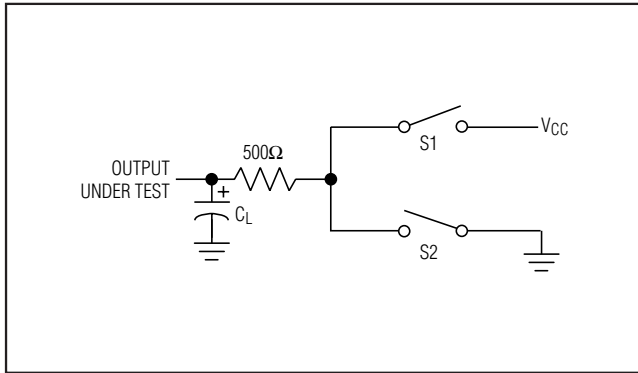

Figure 4. RS-485/422 Driver Enable/Disable Timing Test Load

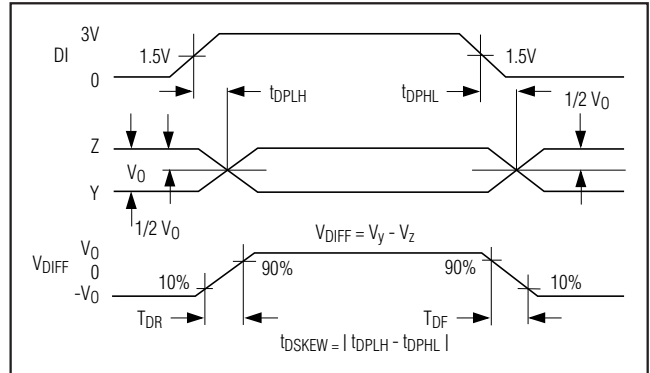

Figure 5. RS-485/422 Driver Propagation Delays

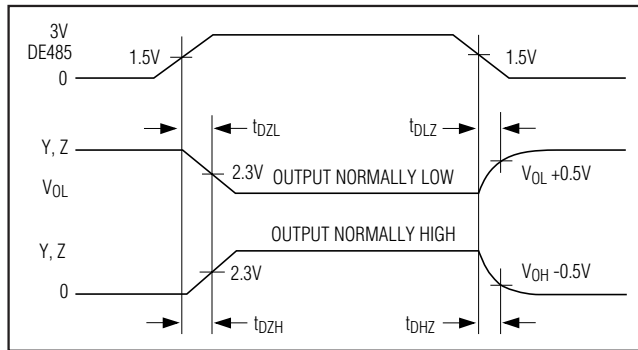

Figure 6. RS-485/422 Driver Enable and Disable Times

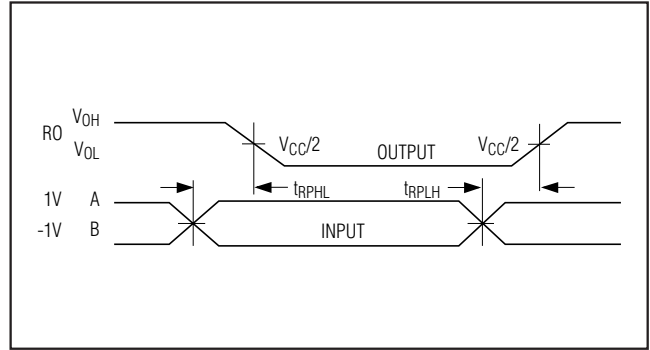

Figure 7. RS-485/422 Receiver Propagation Delays

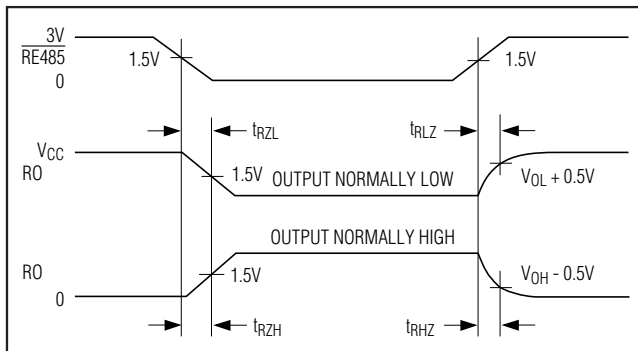

Figure 8. MAX3162 RS-485/422 Receiver Enable and Disable Times

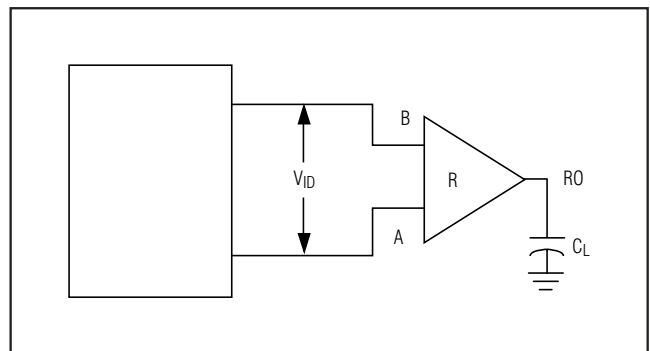

Figure 9. RS-485/422 Receiver Propagation Delays Test Circuit

MAX3160/MAX3161/MAX3162

+3.0V to +5.5V, 1 μ A, RS-232/RS-485/422 Multiprotocol Transceivers

Detailed Description

The MAX3160/MAX3161/MAX3162 3V/5V, multiprotocol transceivers can be pin configured in a number of RS-232 and RS-485/422 interface combinations. These circuit configurations are ideal for the design of RS-232 to RS-485 converters, multiprotocol buses, or any application that requires both RS-232 and RS-485 transceivers. The slew rate of these devices is on-the-fly pin programmable, allowing reduced EMI data rates, or up to 10Mbps RS-485 communications. Power consumption can be reduced to 1 μ A by using the shutdown function, but the RS-232 receivers remain active allowing other devices to query the interface controller. A flow-through pinout and the space-saving SSOP packages (available in the commercial and extended temperature ranges) facilitate board layout.

Device Selection

The MAX3160/MAX3161/MAX3162 contain RS-232 transceivers and an RS-485/422 transceiver. The primary difference between the devices is the multiplexing of the I/O pins.

The MAX3160 has common transmitter outputs and receiver inputs for its RS-232 and RS-485/422 transceivers, and common digital I/O pins. The MAX3160 is optimized for multiprotocol operation on a single interface bus and comes in a 20-pin SSOP.

The MAX3161 has separate transmitter outputs and receiver inputs for its RS-232 and RS-485/422 transceivers, and common digital I/O pins. The MAX3161 is optimized for multiplexing a single UART across two interface buses and comes in a 24-pin SSOP.

The MAX3162 has separate transmitter outputs and receiver inputs for its RS-232 and RS-485/422 transceivers, and separate digital I/O pins. The MAX3162 is optimized for protocol translation between two interface buses and comes in a 28-pin SSOP.

See Tables 1–12, *Functional Diagrams*, and the following descriptions for details on each device.

MAX3160

The MAX3160 is a 2TX/2RX RS-232 transceiver in RS-232 mode, capable of RS-232-compliant communication. Assertion of $\overline{\text{RS-485/RS232}}$ converts the device to a single RS-485 transceiver by multiplexing the RS-232 I/O pins to an RS-485 driver and receiver pair. The logic inputs now control the driver input and the driver enable. One logic output carries the RS-485 receiver output, and the other is three-stated. The receiver input impedance is dependent on the device mode and is 1/4-unit load for RS-485 operation and 5k Ω for RS-232 operation.

MAX3161

The MAX3161 is a 2TX/2RX RS-232 transceiver in RS-232 mode or a single RS-485/422 transceiver in RS-485 mode. When in RS-485 mode, the unused RS-232 transmitter and receiver output pins are disabled. When in RS-232 mode, the RS-485 transmitter outputs are disabled and the RS-232 receiver inputs are 5k Ω to GND. The RS-485 receiver inputs are always 1/8-unit load. Logic lines are shared between the two protocols and are used for signal inputs and as an RS-485 driver enable.

MAX3162

The MAX3162 is a 2TX/2RX RS-232 transceiver and a single RS-485/422 transceiver simultaneously. All drivers, receivers, and transmitters can be enabled or disabled by pin configuration. All outputs are high-Z when not activated. RS-232 receiver inputs are 5k Ω when enabled, and RS-485 receiver inputs are 1/8-unit load.

FAST Mode operation

The FAST control pin is used to select the slew-rate limiting of the RS-232 transmitters and the RS-485/422 drivers. With FAST unasserted, the RS-232 transmitters and the RS-485/422 driver are slew-rate limited to reduce EMI. RS-232 data rates up to 1Mbps and RS-485/422 data rates up to 10Mbps are possible when FAST is asserted. FAST can be changed during operation without interrupting data communications.

Half-Duplex RS-485/422 Operation

Asserting HDPLX places the MAX3160/MAX3161 in half-duplex mode. The RS-485 receiver inputs are internally connected to the driver outputs. The RS-485 driver outputs can be disabled by pulling DE485 low. HDPLX has no effect on RS-232 operation.

Low-Power Shutdown

The MAX3160/MAX3161/MAX3162 have an active-low shutdown control input, $\overline{\text{SHDN}}$. When driven low, the charge pump and transmitters are shut down and supply current is reduced to 1 μ A. The RS-232 receiver outputs remain active if in RS-232 mode. The charge-pump capacitors must be recharged when coming out of shutdown before resuming operation in either RS-232 or RS-485/422 mode (Figure 10).

Dual Charge-Pump Voltage Converter

The MAX3160/MAX3161/MAX3162s' internal power supply consists of a regulated dual charge pump that provides output voltages of +5.5V (doubling charge pump) and -5.5V (inverting charge pump) for input voltages (V_{CC}) over the 3.0V to 5.5V range. The charge pumps operate in a discontinuous mode: if the magnitude of either output voltage is less than 5.5V, the

MAX3160/MAX3161/MAX3162

+3.0V to +5.5V, 1 μ A, RS-232/RS-485/422 Multiprotocol Transceivers

charge pumps are enabled; if the magnitude of both output voltages exceeds 5.5V, the charge pumps are disabled. Each charge pump requires a flying capacitor (C1, C2) and a reservoir capacitor (C3, C4) to generate the V+ and V- supplies (see *Functional Diagrams*).

RS-485/422 Transceivers

The MAX3160/MAX3161/MAX3162 RS-485/422 transceivers feature fail-safe circuitry that guarantees a logic-high receiver output when the receiver inputs are open or shorted, or when they are connected to a terminated transmission line with all drivers disabled (see *Fail-Safe*). The MAX3160/MAX3161/MAX3162 also feature pin-selectable reduced slew-rate drivers that minimize EMI and reduce reflections caused by improperly terminated cables, allowing error-free data transmission up to 250kbps (see *RS-485/422 Reduced EMI and Reflections*). The transmitters may operate at speeds up to 10Mbps with the slew-rate limiting disabled. Drivers are short-circuit current limited and thermally limited to protect them against excessive power dissipation. Half-duplex communication is enabled by driving HDPLX high.

Fail-Safe

The MAX3160/MAX3161/MAX3162 **guarantee** a logic-high RS-485 receiver output when the receiver inputs are shorted or open, or when they are connected to a terminated transmission line with all drivers disabled. This is done by having the receiver threshold between -50mV and -200mV. If the differential receiver input voltage (A-B) is greater than or equal to -50mV, RO is logic high. If A-B is less than or equal to -200mV, RO is logic low. In the case of a terminated bus with all transmitters disabled, the receiver's differential input voltage is pulled to GND by the termination. This results in a logic high with a 50mV minimum noise margin. Unlike other fail-safe devices, the -50mV to -200mV threshold complies with the ± 200 mV EIA/TIA-485 standard.

RS-232 Transceivers

The MAX3160/MAX3161/MAX3162 RS-232 transmitters are inverting-level translators that convert CMOS-logic levels to ± 5.0 V EIA/TIA-232-compliant levels. The transmitters are guaranteed at a 250kbps data rate in slew-rate limited mode (FAST = GND) with worst-case loads of 3k Ω in parallel with 1000pF. Data rates up to 1Mbps can be achieved by asserting FAST. When powered down or in shutdown, the MAX3160/MAX3161/MAX3162 outputs are high impedance and can be driven to ± 12 V. The transmitter inputs do not have pullup resistors. Connect unused inputs to ground or VCC.

The receivers convert RS-232 signals to CMOS-logic output levels. All receivers have inverting outputs that remain active in shutdown. The MAX3160/MAX3161/MAX3162 permit their receiver inputs to be driven to Dia ± 25 V. Floating receiver input signals are pulled to ground through internal 5k Ω resistors, forcing the outputs to a logic high. The MAX3162 has transmitter and receiver enable pins that allow its outputs to be three-stated.

Applications Information

Capacitor Selection

The capacitor type used for C1–C4 is not critical for proper operation; polarized or nonpolarized capacitors can be used. Ceramic chip capacitors with an X7R dielectric provide the best combination of performance, cost, and size. The charge pump requires 0.1 μ F capacitors for 3.3V operation. For other supply voltages, see Table 13 for required capacitor values. Do not use values smaller than those listed in Table 13. Increasing the capacitor values reduces ripple on the transmitter outputs and slightly reduces power consumption. C2, C3, and C4 can be changed without changing C1's value. **However, do not increase C1 without also increasing the values of C2, C3, C4, and CBYPASS to maintain the proper ratios to the other capacitors.**

When using the minimum required capacitor values, make sure the capacitance value does not degrade excessively with temperature or voltage. This is typical of Y5V and Z5U dielectric ceramic capacitors. If in doubt, use capacitors with a larger nominal value. The capacitor's equivalent series resistance (ESR), which usually rises at low temperatures, influences the amount of ripple on V+ and V-.

Power-Supply Decoupling

In applications that are sensitive to power-supply noise, decouple VCC to ground with a capacitor of the same value as reservoir capacitors C2, C3, and C4. Connect the bypass capacitor as close to the IC as possible.

RS-232 Transmitter Outputs when Exiting Shutdown

Figure 10 shows two transmitter outputs when exiting shutdown mode. As they become active, the two transmitter outputs are shown going to opposite RS-232 levels (one transmitter input is high, the other is low). Each transmitter is loaded with 3k Ω in parallel with 1000pF. The transmitter outputs display no ringing or undesirable transients as they come out of shutdown. Note that the transmitters are enabled only when V- exceeds approximately -3V.

MAX3160/MAX3161/MAX3162

+3.0V to +5.5V, 1µA, RS-232/RS-485/422 Multiprotocol Transceivers

Truth Tables

RS-232 Transmitters

Table 1. MAX3160

INPUTS			OUTPUTS
SHDN	RS485 RS232	DI/T1IN, DE485/T2IN	Z(B)/T1OUT, Y(A)/T2OUT
0	X	X	1/8 Unit Load
1	0	0	1
1	0	1	0
1	1	X	RS-485 Mode

Table 2. MAX3161

INPUTS			OUTPUTS
SHDN	RS-485/ RS-232	DI/T1IN, DE485/T2IN	T1OUT, T2OUT
0	X	X	High-Z
1	0	0	1
1	0	1	0
1	1	X	High-Z

Table 3. MAX3162

INPUTS			OUTPUTS
SHDN	TE232	T1IN,T2IN	T1OUT, T2OUT
0	X	X	High-Z
X	0	X	High-Z
1	1	0	1
1	1	1	0

High Data Rates

The MAX3160/MAX3161/MAX3162 maintain the RS-232 $\pm 5.0V$ required minimum transmitter output voltage even at high data rates. Figure 11 shows a transmitter loopback test circuit. Figure 12 shows a loopback test result at 250kbps, and Figure 13 shows the same test at 1000kbps. Figure 12 demonstrates a single slew-rate limited transmitter driven at 250kbps (FAST = GND) into an RS-232 load in parallel with 1000pF. Figure 13 shows

RS-232 Receivers

Table 4. MAX3160

INPUTS			OUTPUTS
SHDN	RS-485/ RS-232	B/R1IN, A/R2IN	R1OUT, RO/R2OUT
X	0	0	1
X	0	1	0
X	0	Inputs Open	1
X	1	X	R1OUT High-Z, RO/R2OUT in RS-485 mode

Table 5. MAX3161

INPUTS			OUTPUTS
SHDN	RS-485/ RS-232	R1IN, R2IN	R1OUT, RO/R2OUT
X	0	0	1
X	0	1	0
X	0	Inputs Open	1
X	1	X	R1OUT High-Z, RO/R2OUT in RS-485 mode

Table 6. MAX3162

INPUTS			OUTPUTS
SHDN	RE232	R1IN, R2IN	R1OUT, R2OUT
X	1	X	High-Z
X	0	0	1
X	0	1	0
X	0	Inputs open	1

a single transmitter driven at 1Mbps (FAST asserted), loaded with an RS-232 receiver in parallel with 1000pF. These transceivers maintain the RS-232 $\pm 5.0V$ minimum transmitter output voltage at data rates up to 1Mbps.

256 Transceivers on the Bus

The standard RS-485 receiver input impedance is 12k Ω (one-unit load), and the standard driver can drive up to 32-unit loads. The MAX3160 has a 1/4-unit load receiver input impedance (48k Ω), allowing up to 128 trans-

MAX3160/MAX3161/MAX3162

+3.0V to +5.5V, 1 μ A, RS-232/RS-485/422

Multiprotocol Transceivers

Truth Tables (continued)

RS-485/422 Drivers

Table 7. MAX3160

INPUTS				OUTPUTS	
SHDN	RS485/RS232	DE485/T2IN	DI/T1IN	Z(B)/T1OUT	Y(A)/T2OUT
0	1	X	X	1/8 Unit Load	1/8 Unit Load
1	1	0	X	1/8 Unit Load	1/8 Unit Load
1	1	1	0	1	0
1	1	1	1	0	1
X	0	X	X	RS-232 Mode	

Table 8. MAX3161

INPUTS				OUTPUTS	
SHDN	RS485/RS232	DE485/T2IN	DI/T1IN	Z(B)	Y(A)
0	X	X	X	1/8 Unit Load	1/8 Unit Load
X	0	X	X	1/8 Unit Load	1/8 Unit Load
X	X	0	X	1/8 Unit Load	1/8 Unit Load
1	1	1	0	1	0
1	1	1	1	0	1

Table 9. MAX3162

INPUTS			OUTPUTS	
SHDN	DE485	DI	Z	Y
0	X	X	High-Z	High-Z
X	0	X	High-Z	High-Z
1	1	0	1	0
1	1	1	0	1

RS-485/422 Receivers

Table 10. MAX3160

INPUTS					OUTPUT
RS485/RS232	SHDN	HDPLX	A - B*	Y - Z*	RO/R2OUT
1	0	X	X	X	High-Z Up to V _{CC}
1	1	0	$\geq -50\text{mV}$	X	1
1	1	0	$\leq -200\text{mV}$	X	0
1	1	0	Floating	X	1
1	1	1	X	$\geq -50\text{mV}$	1
1	1	1	X	$\leq -200\text{mV}$	0
1	1	1	X	Floating	1
0	X	X	X	X	RS-232 Mode

*Y and Z correspond to pins Y(A)/T2OUT and Z(B)/T1OUT. A and B correspond to pins A/R2IN and B/R1IN.

MAX3160/MAX3161/MAX3162

+3.0V to +5.5V, 1μA, RS-232/RS-485/422 Multiprotocol Transceivers

Truth Tables (continued)

Table 11. MAX3161

RS485/RS232		INPUTS			OUTPUT
	SHDN	HDPLX	A - B	Y(A) - Z(B)	RO/R2OUT
1	0	X	X	X	High-Z up to V _{CC}
1	1	0	≥-50mV	X	1
1	1	0	≤-200mV	X	0
1	1	0	Floating	X	1
1	1	1	X	≥-50mV	1
1	1	1	X	≤-200mV	0
1	1	1	X	Floating	1
0	X	X	X	X	RS-232 Mode

Table 12. MAX3162

INPUTS			OUTPUT
SHDN	RE485	A - B	RO
0	X	X	High-Z
X	1	X	High-Z
1	0	≥-50mV	1
1	0	≤-200mV	0
1	0	Inputs Open	1

ceivers to be connected in parallel on one communication line. The MAX3161/MAX3162 have a 1/8-unit load receiver input impedance (96kΩ), allowing up to 256 transceivers to be connected in parallel on one communication line. Any combination of these devices and/or other RS-485 transceivers with a total of 32-unit loads or fewer can be connected to the line.

The MAX3160/MAX3161/MAX3162 RS-485 driver outputs are 1/8-unit load when disabled. This impedance may be reduced if the D1 pin is toggled at a high frequency. With no power applied (V_{CC} = GND), the RS-485 transmitter output impedances typically go to 1/2-unit load on the MAX3161/MAX3162, and to one-unit load on the MAX3160.

Driver Output Protection

Two mechanisms prevent excessive output current and power dissipation caused by faults or by bus contention. The first, a foldback current limit on the output stage, provides immediate protection against short circuits over the whole common-mode voltage range (see

Table 13. Required Minimum Capacitance Values

SUPPLY VOLTAGE (V)	C1 (μF)	C2, C3, C4, CBYPASS (μF)
+3.0 TO +3.6	0.1	0.1
+4.5 TO +5.5	0.047	0.33
+3.0 TO +5.5	0.1	0.47

Typical Operating Characteristics). The second, a thermal shutdown circuit, forces the driver outputs into a high-impedance state if the die temperature becomes excessive.

Protection Against Wiring Faults

EIA/TIA-485 standards require a common input voltage range of -7V to +12V to prevent damage to the device. The MAX3160/MAX3161/MAX3162 inputs are protected to RS-232 levels of ±25V for the receiver inputs and ±13.2V for the transmitter/driver outputs. This provides additional protection for the RS-485 transceivers against ground differential or faults due to miswiring.

RS-485/422 Reduced EMI and Reflections

The MAX3160/MAX3161/MAX3162 can be configured for slew-rate limiting by pulling FAST low. This minimizes EMI and reduces reflections caused by improperly terminated cables. Operation in slew-rate limited mode reduces the amplitudes of high-frequency harmonics.

MAX3160/MAX3161/MAX3162

+3.0V to +5.5V, 1 μ A, RS-232/RS-485/422 Multiprotocol Transceivers

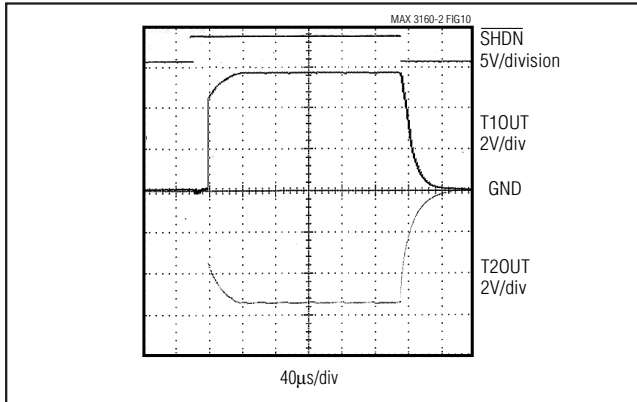

Figure 10. MAX3160 RS-232 Transmitter Outputs When Exiting Shutdown

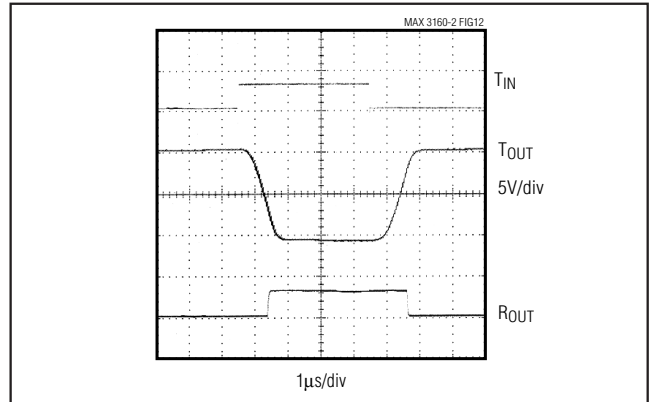

Figure 12. RS-232 Loopback Test Result at 250kbps, FAST = Low

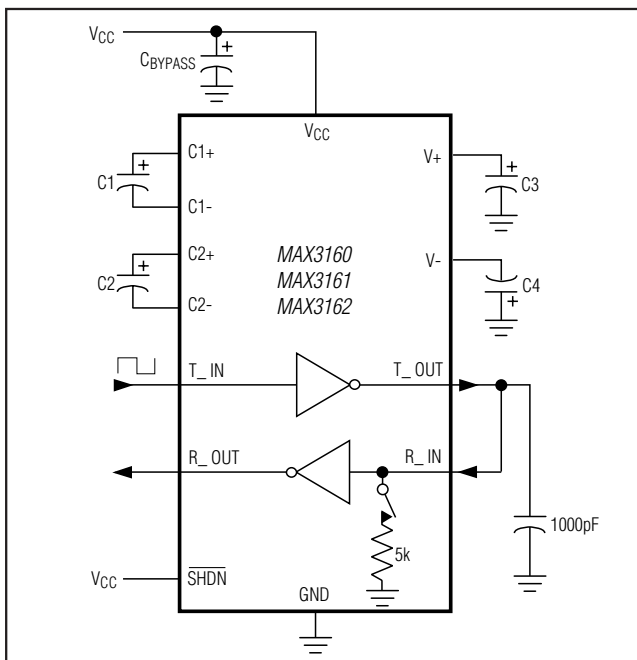

Figure 11. Loopback Test Circuit

RS-485/422 Line Length vs. Data Length

The RS-485/422 standard covers line lengths up to 4000 feet. For line lengths greater than 4000 feet, use the repeater application shown in Figure 14.

RS-232/RS-485 Protocol Translator

Figure 15 shows the MAX3162 configured as an RS-232/RS-485 protocol translator. The direction of translation is controlled through the RTS signal (R1IN). The

SPI is a trademark of Motorola, Inc.

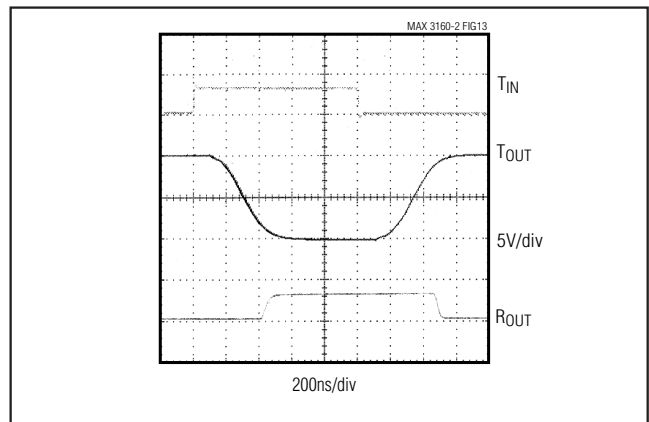

Figure 13. RS-232 Loopback Test Result at 1000kbps, FAST = High

single-ended RS-232 receiver input signal is translated to a differential RS-485 transmitter output. Similarly, a differential RS-485 receiver input signal is translated to a single-ended RS-232 transmitter output. RS-232 data received on R2IN is transmitted as an RS-485 signal on Z and Y. RS-485 signals received on A and B are transmitted as an RS-232 signal on T1OUT.

Multiprotocol Bus

The *Typical Operating Circuit* shows a standard application for the MAX3160. The MAX3160's output pins are multiplexed between RS-232 and RS-485 protocols by a microprocessor (μ P). The μ P also directs the shutdown functions, enable lines, and the duplex of the MAX3160. Data is transmitted to the MAX3100 UART through an SPI™ port. The UART asynchronously

MAX3160/MAX3161/MAX3162

+3.0V to +5.5V, 1 μ A, RS-232/RS-485/422 Multiprotocol Transceivers

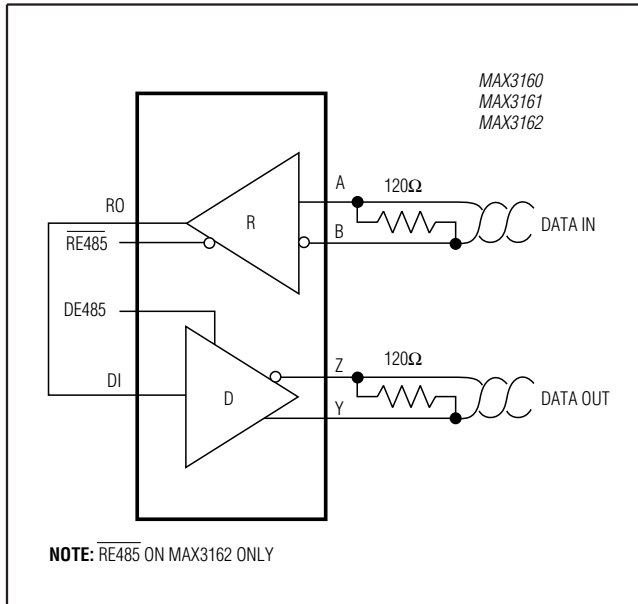

Figure 14. RS-485 Line Repeater

transfers data through the MAX3160 to the pin-selected RS-232 or RS-485 protocol; see Table 14 for commonly used cable connections.

Multiprotocol Bus Multiplexer

The *Typical Application Circuit* shows the MAX3161 configured as a multiprotocol bus multiplexer. The MAX3161 separates the RS-232 and RS-485 lines, but shares the logic pins between modes. This application allows the μ P to monitor a point-to-point RS-232 bus, and a multidrop RS-485 interface. The MAX3100 UART asynchronously transfers data through the MAX3161 to the pin-selected RS-232 or RS-485 protocol.

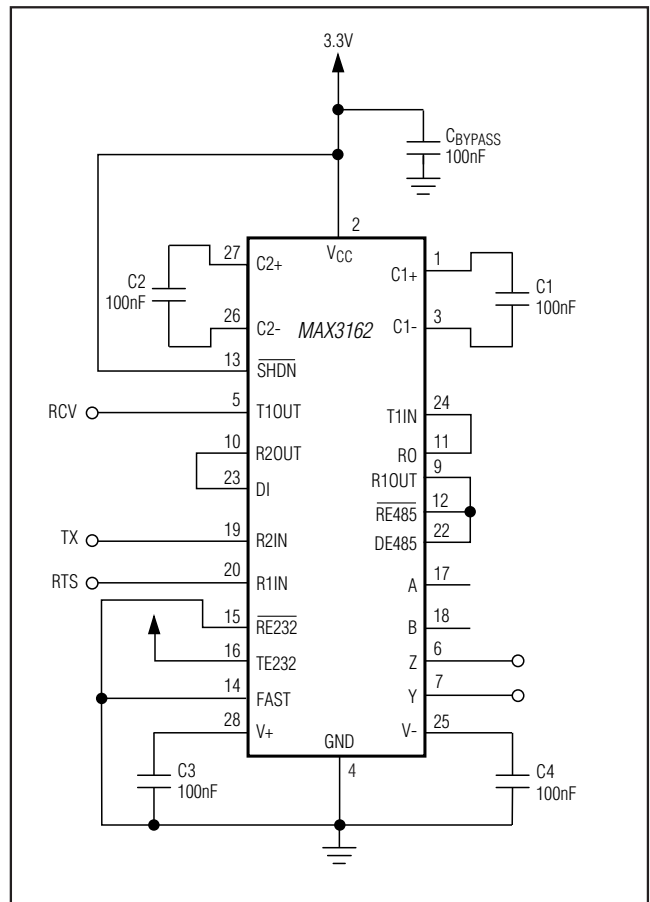

Figure 15. Protocol Translator

MAX3160/MAX3161/MAX3162

+3.0V to +5.5V, 1µA, RS-232/RS-485/422 Multiprotocol Transceivers

Table 14. Cable Connections Commonly Used for EIA/TIA-232 and V.24 Asynchronous Interfaces

EIA/TIA-232 STANDARD	CONNECTOR PIN	MAX3160 MAX3161 MAX3162	PIN NUMBER			FUNCTION (as seen by DTE)
			EQUIVALENT	MAX3160	MAX3161	
DCD	1					Data Carrier Detect
RD	2	R2IN	13	17	19	Received Data
TD	3	T1OUT	5	5	5	Transmitted Data
DTR	4					Data Terminal Ready
SG	5	GND	4	4	4	Signal Ground
DSR	6					Data Set Ready
RTS	7	T2OUT	6	8	8	Request to Send (= DTE ready)
CTS	8	R1IN	14	18	20	Clear to Send (= DCE ready)
RI	9					Ring Indicator

Typical Application Circuit

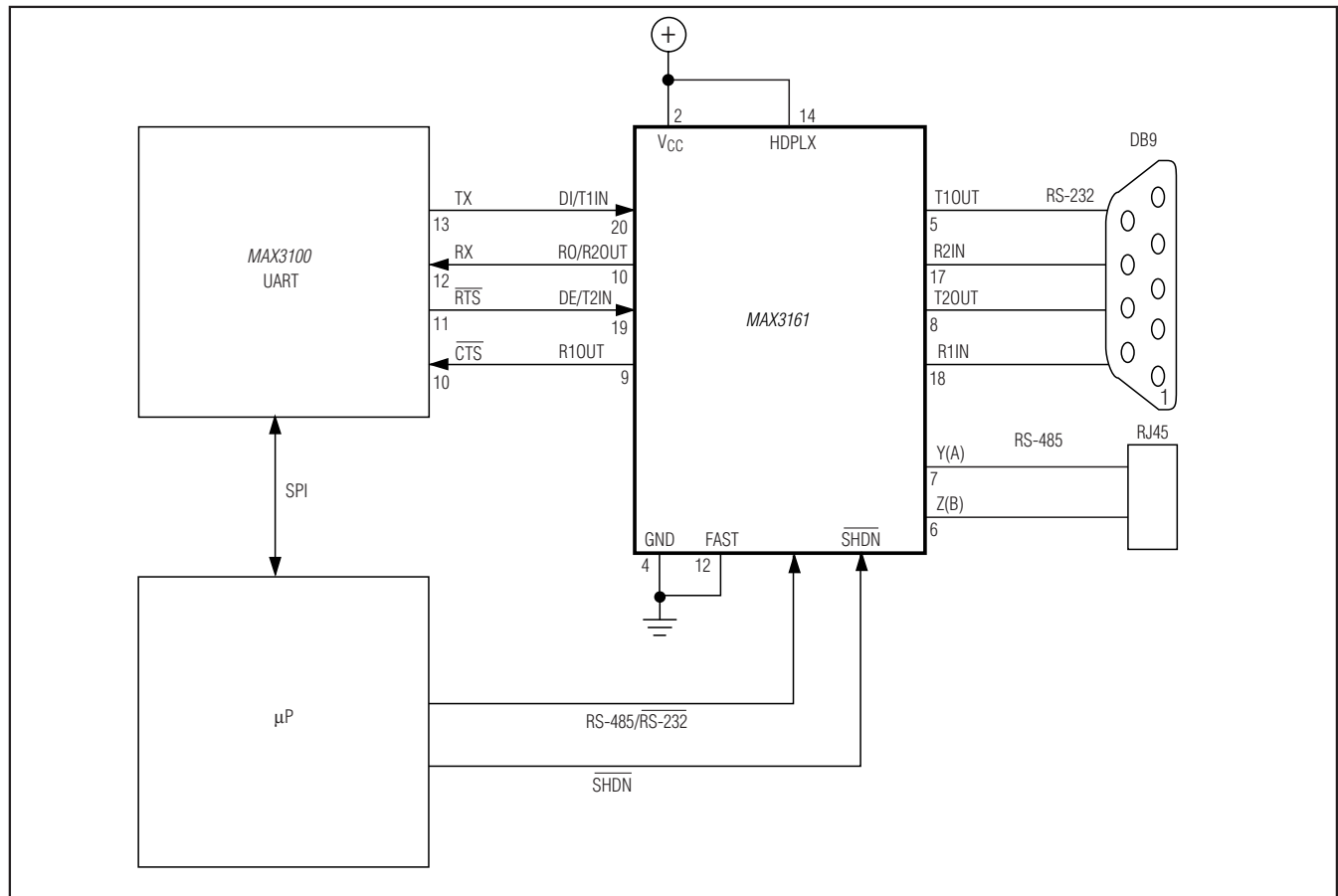

MAX3160/MAX3161/MAX3162

**+3.0V to +5.5V, 1µA, RS-232/RS-485/422
Multiprotocol Transceivers**

Pin Configurations

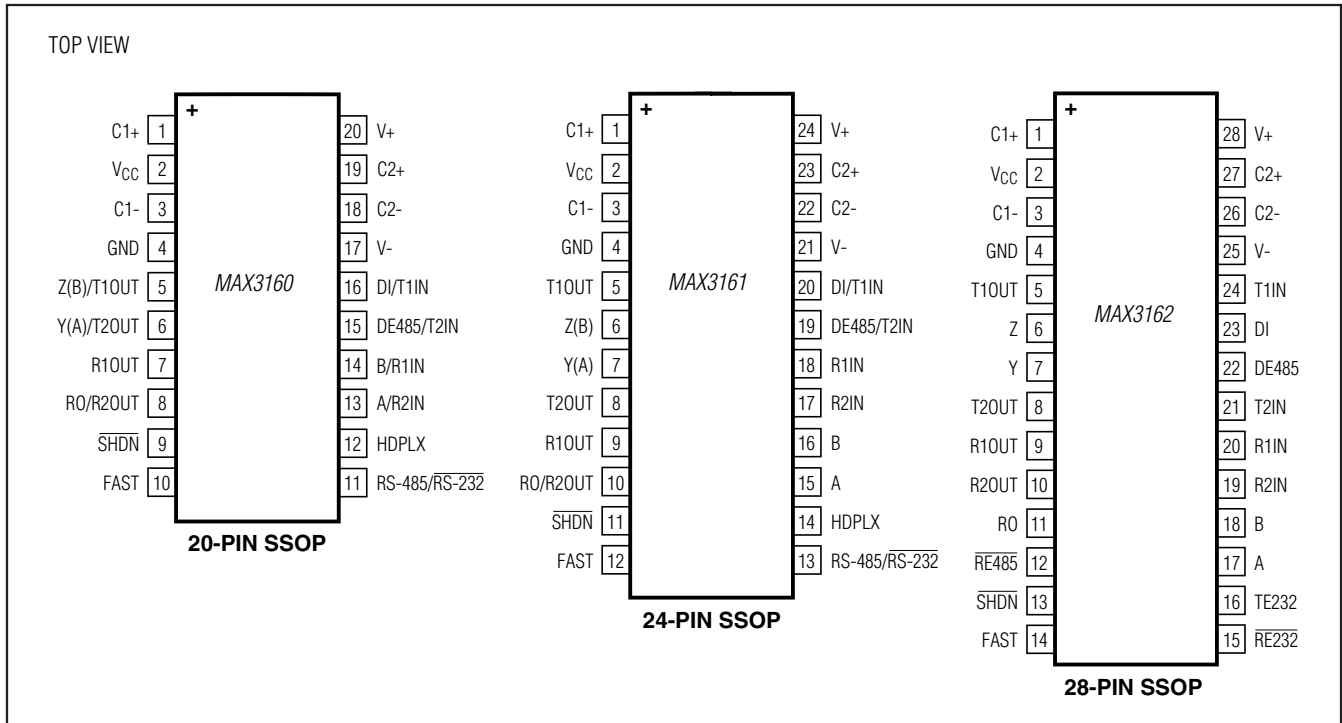

Selector Guide

PART	DUAL-MODE	FLOW-THROUGH PIN-OUT	RS-485 INPUT UNIT LOADS
MAX3160	No	Yes	1/4
MAX3161	No	No	1/8
MAX3162	Yes	Yes	1/8

Chip Information

PROCESS: BiCMOS

Package Information

For the latest package outline information and land patterns, go to www.maxim-ic.com/packages. Note that a "+", "#", or "-" in the package code indicates RoHS status only. Package drawings may show a different suffix character, but the drawing pertains to the package regardless of RoHS status.

PACKAGE TYPE	PACKAGE CODE	DOCUMENT NO.
20 SSOP	A20+1	21-0056
24 SSOP	A24+3	21-0056
28 SSOP	A28+3	21-0056

MAX3160/MAX3161/MAX3162

+3.0V to+5.5V, 1 μ A, RS-232/RS-485/422 Multiprotocol Transceivers

Revision History

REVISION NUMBER	REVISION DATE	DESCRIPTION	PAGES CHANGED
2	12/09	Corrected the "Continuous Power Dissipation" specifications under the <i>Absolute Maximum Ratings</i> .	2
		Changed pin labels in the <i>Functional Diagrams</i> .	11
		Deleted "TRANSISTOR COUNT: 1580" and added "PROCESS: BiCMOS" to the <i>Chip Information</i> .	22



Maxim cannot assume responsibility for use of any circuitry other than circuitry entirely embodied in a Maxim product. No circuit patent licenses are implied. Maxim reserves the right to change the circuitry and specifications without notice at any time. The parametric values (min and max limits) shown in the Electrical Characteristics table are guaranteed. Other parametric values quoted in this data sheet are provided for guidance.

Maxim Integrated 160 Rio Robles, San Jose, CA 95134 USA 1-408-601-1000

23