



## 512K X 8 BIT LOW POWER CMOS SRAM

**FEATURES**

- Access time : 55 ns
- Low power consumption:  
Operating current : 30 mA (TYP.)  
Standby current : 4  $\mu$ A (TYP.)
- Single 2.7V ~ 5.5V power supply
- All outputs TTL compatible
- Fully static operation
- Tri-state output
- Data retention voltage : 1.5V (MIN.)
- All products ROHS Compliant
- Package : 32-pin 450 mil SOP; 32-pin 600 mil P-DIP  
32-pin 8mm x 20mm TSOP-I  
32-pin 8mm x 13.4mm STSOP  
36-ball 6mm x 8mm TFBGA  
32-pin 400 mil TSOP-II

**GENERAL DESCRIPTION**

The AS6C4008 is a 4,194,304-bit low power CMOS static random access memory organized as 524,288 words by 8 bits. It is fabricated using very high performance, high reliability CMOS technology. Its standby current is stable within the range of operating temperature.

The AS6C4008 is well designed for very low power system applications, and particularly well suited for battery back-up non-volatile memory application.

The AS6C4008 operates from a single power supply of 2.7V ~ 5.5V and all inputs and outputs are fully TTL compatible

**PRODUCT FAMILY**

Product Family	Operating Temperature	Vcc Range	Speed	Power Dissipation	
				Standby(I <sub>SB1</sub> TYP.)	Operating(I <sub>CC</sub> ,TYP.)
AS6C4008	-40 ~ +85 °C	2.7 ~ 5.5V	55ns	4 $\mu$ A(LL)	30mA

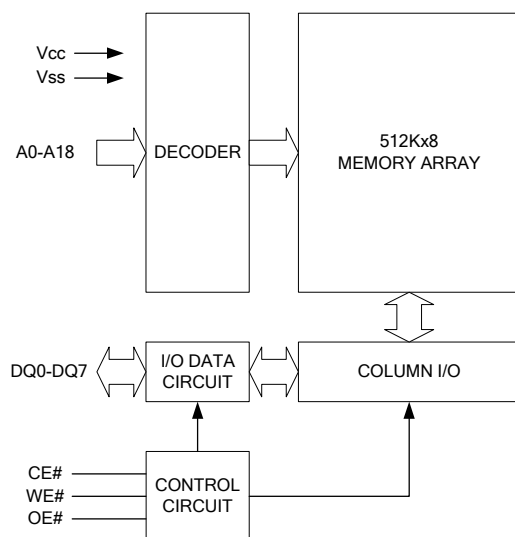
**FUNCTIONAL BLOCK DIAGRAM****PIN DESCRIPTION\*\***

SYMBOL	DESCRIPTION
A0 - A18	Address Inputs
DQ0 - DQ7	Data Inputs/Outputs
CE#	Chip Enable Inputs
WE#	Write Enable Input
OE#	Output Enable Input
Vcc	Power Supply
Vss	Ground
NC	No Connection



512K X 8 BIT LOW POWER CMOS SRAM

**PIN CONFIGURATION**

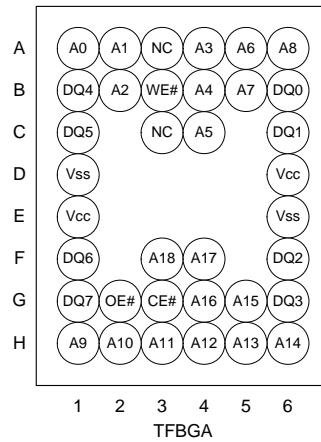
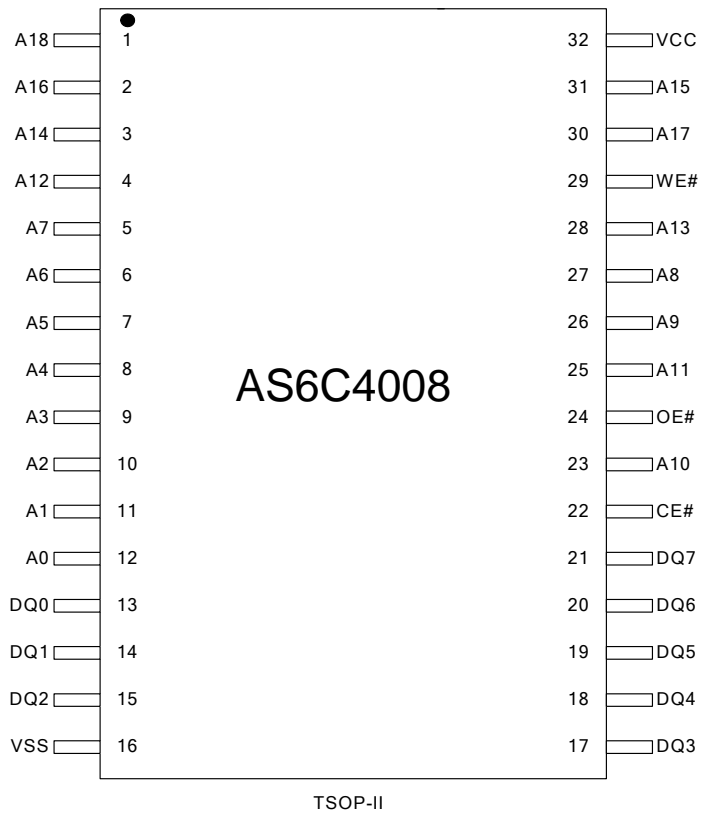
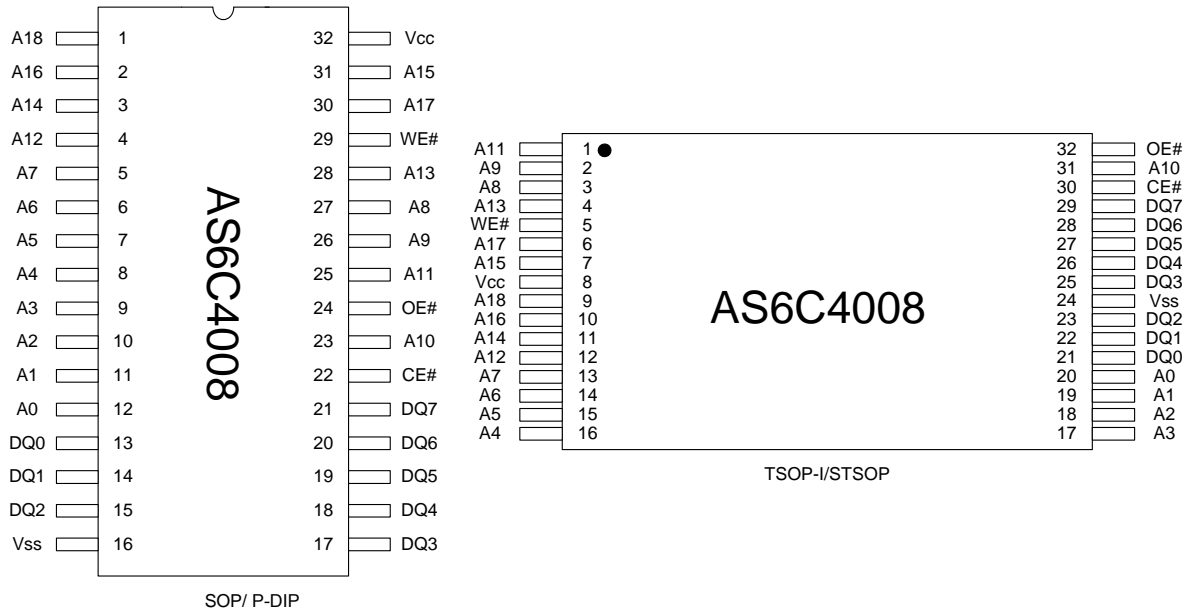



## 512K X 8 BIT LOW POWER CMOS SRAM

**ABSOLUTE MAXIMUM RATINGS\***

PARAMETER	SYMBOL	RATING	UNIT
Terminal Voltage with Respect to V <sub>SS</sub>	V <sub>TERM</sub>	-0.5 to 6.5	V
Operating Temperature	T <sub>A</sub>	0 to 70(C grade)	C°
		-40 to 85(I grade)	
Storage Temperature	T <sub>STG</sub>	-65 to 150	C°
Power Dissipation	P <sub>D</sub>	1	W
DC Output Current	I <sub>OUT</sub>	50	mA
Soldering Temperature (under 10 sec)	T <sub>SOLDER</sub>	260	C°

\*Stresses greater than those listed under "Absolute Maximum Ratings" may cause permanent damage to the device. This is a stress rating only and functional operation of the device or any other conditions above those indicated in the operational sections of this specification is not implied. Exposure to the absolute maximum rating conditions for extended period may affect device reliability.

**TRUTH TABLE**

MODE	CE#	OE#	WE#	I/O OPERATION	SUPPLY CURRENT
Standby	H	X	X	High-Z	I <sub>SB1</sub>
Output Disable	L	H	H	High-Z	I <sub>CC</sub> , I <sub>CC1</sub>
Read	L	L	H	D <sub>OUT</sub>	I <sub>CC</sub> , I <sub>CC1</sub>
Write	L	X	L	D <sub>IN</sub>	I <sub>CC</sub> , I <sub>CC1</sub>

Note: H = V<sub>IH</sub>, L = V<sub>IL</sub>, X = Don't care.

**DC ELECTRICAL CHARACTERISTICS**

PARAMETER	SYMBOL	TEST CONDITION	MIN.	TYP. <sup>3</sup>	MAX.	UNIT
Supply Voltage	V <sub>CC</sub>		2.7	3.0	5.5	V
Input High Voltage	V <sub>IH</sub> <sup>1</sup>		0.7*V <sub>CC</sub>	-	V <sub>CC</sub> +0.3	V
Input Low Voltage	V <sub>IL</sub> <sup>1</sup>		-0.2	-	0.6	V
Input Leakage Current	I <sub>LI</sub>	V <sub>CC</sub> ≥ V <sub>IN</sub> ≥ V <sub>SS</sub>	-1	-	1	μA
Output Leakage Current	I <sub>LO</sub>	V <sub>CC</sub> ≥ V <sub>OUT</sub> ≥ V <sub>SS</sub> , Output Disabled	-1	-	1	μA
Output High Voltage	V <sub>OH</sub>	I <sub>OH</sub> = -1mA	2.4	-	-	V
Output Low Voltage	V <sub>OL</sub>	I <sub>OL</sub> = 2mA	-	-	0.4	V
Average Operating Power supply Current	I <sub>CC</sub>	Cycle time = Min. CE# = 0.2V, I <sub>I/O</sub> = 0mA other pins at 0.2V or V <sub>CC</sub> - 0.2V	-55	30	60	mA
	I <sub>CC1</sub>	Cycle time = 1μs CE# = 0.2V, I <sub>I/O</sub> = 0mA other pins at 0.2V or V <sub>CC</sub> - 0.2V	-	4	10	mA
Standby Power Supply Current	I <sub>SB1</sub>	CE# ≥ V <sub>CC</sub> - 0.2V	-LL	4	50 <sup>4</sup>	μA
			-LLE/-LLI	4	50 <sup>4</sup>	μA

- Notes: 1. V<sub>IH</sub>(max) = V<sub>CC</sub> + 3.0V for pulse width less than 10ns. V<sub>IL</sub>(min) = V<sub>SS</sub> - 3.0V for pulse width less than 10ns.  
 2. Over/Undershoot specifications are characterized, not 100% tested.  
 3. Typical values are included for reference only and are not guaranteed or tested.  
 Typical values are measured at V<sub>CC</sub> = V<sub>CC</sub>(TYP.) and T<sub>A</sub> = 25°C  
 4. 25μA for special request



## 512K X 8 BIT LOW POWER CMOS SRAM

**CAPACITANCE** ( $T_A = 25^\circ\text{C}$ ,  $f = 1.0\text{MHz}$ )

PARAMETER	SYMBOL	MIN.	MAX	UNIT
Input Capacitance	$C_{IN}$	-	6	pF
Input/Output Capacitance	$C_{I/O}$	-	8	pF

Note : These parameters are guaranteed by device characterization, but not production tested.

**AC TEST CONDITIONS**

Input Pulse Levels	0.2V to $V_{CC} - 0.2V$
Input Rise and Fall Times	3ns
Input and Output Timing Reference Levels	1.5V
Output Load	$C_L = 30\text{pF} + 1\text{TTL}$ , $I_{OH}/I_{OL} = -2\text{mA}/4\text{mA}$

**AC ELECTRICAL CHARACTERISTICS****(1) READ CYCLE**

PARAMETER	SYM.	AS6C4008-55		UNIT
		MIN.	MAX.	
Read Cycle Time	$t_{RC}$	55	-	ns
Address Access Time	$t_{AA}$	-	55	ns
Chip Enable Access Time	$t_{ACE}$	-	55	ns
Output Enable Access Time	$t_{OE}$	-	30	ns
Chip Enable to Output in Low-Z	$t_{CLZ}^*$	10	-	ns
Output Enable to Output in Low-Z	$t_{OLZ}^*$	5	-	ns
Chip Disable to Output in High-Z	$t_{CHZ}^*$	-	20	ns
Output Disable to Output in High-Z	$t_{OHZ}^*$	-	20	ns
Output Hold from Address Change	$t_{OH}$	10	-	ns

**(2) WRITE CYCLE**

PARAMETER	SYM.	AS6C4008-55		UNIT
		MIN.	MAX.	
Write Cycle Time	$t_{WC}$	55	-	ns
Address Valid to End of Write	$t_{AW}$	50	-	ns
Chip Enable to End of Write	$t_{CW}$	50	-	ns
Address Set-up Time	$t_{AS}$	0	-	ns
Write Pulse Width	$t_{WP}$	45	-	ns
Write Recovery Time	$t_{WR}$	0	-	ns
Data to Write Time Overlap	$t_{DW}$	25	-	ns
Data Hold from End of Write Time	$t_{DH}$	0	-	ns
Output Active from End of Write	$t_{OW}^*$	5	-	ns
Write to Output in High-Z	$t_{WHZ}^*$	-	20	ns

\*These parameters are guaranteed by device characterization, but not production tested.

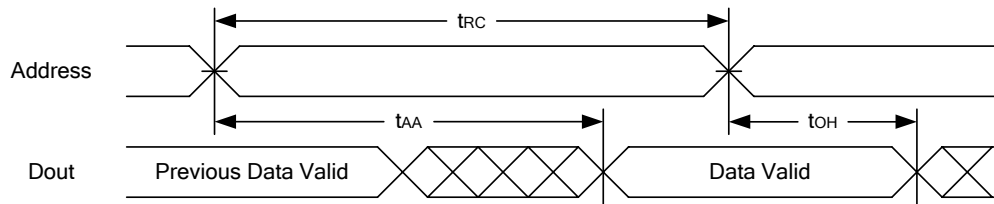
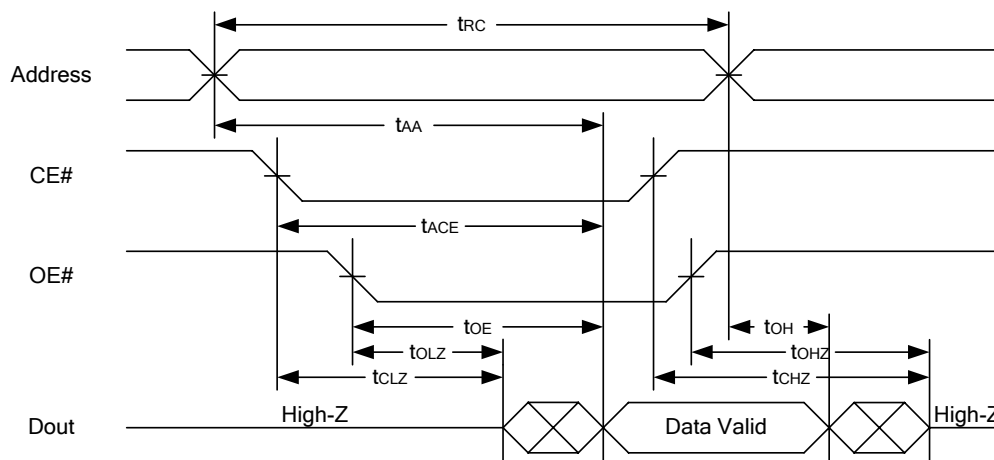

## 512K X 8 BIT LOW POWER CMOS SRAM

**TIMING WAVEFORMS****READ CYCLE 1 (Address Controlled) (1,2)****READ CYCLE 2 (CE# and OE# Controlled) (1,3,4,5)**

## Notes :

1. WE# is high for read cycle.
2. Device is continuously selected OE# = low, CE# = low.
3. Address must be valid prior to or coincident with CE# = low.; otherwise tAA is the limiting parameter.
4. tCLZ, tOLZ, tCHZ and tOHZ are specified with CL = 5pF. Transition is measured ±500mV from steady state.
5. At any given temperature and voltage condition, tCHZ is less than tCLZ, tOHZ is less than tOLZ.



## 512K X 8 BIT LOW POWER CMOS SRAM

## WRITE CYCLE 1 (WE# Controlled) (1,2,3,5,6)

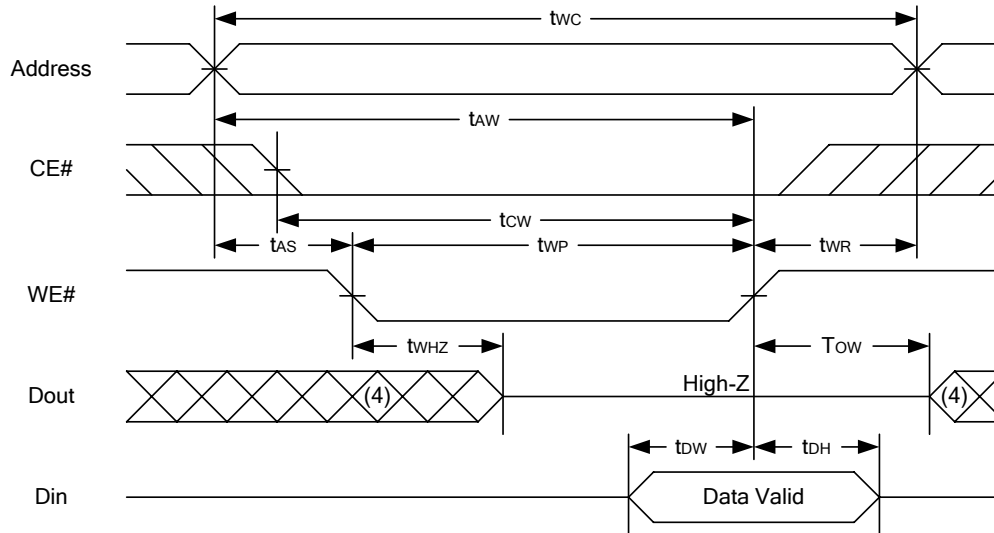

## WRITE CYCLE 2 (CE# Controlled) (1,2,5,6)

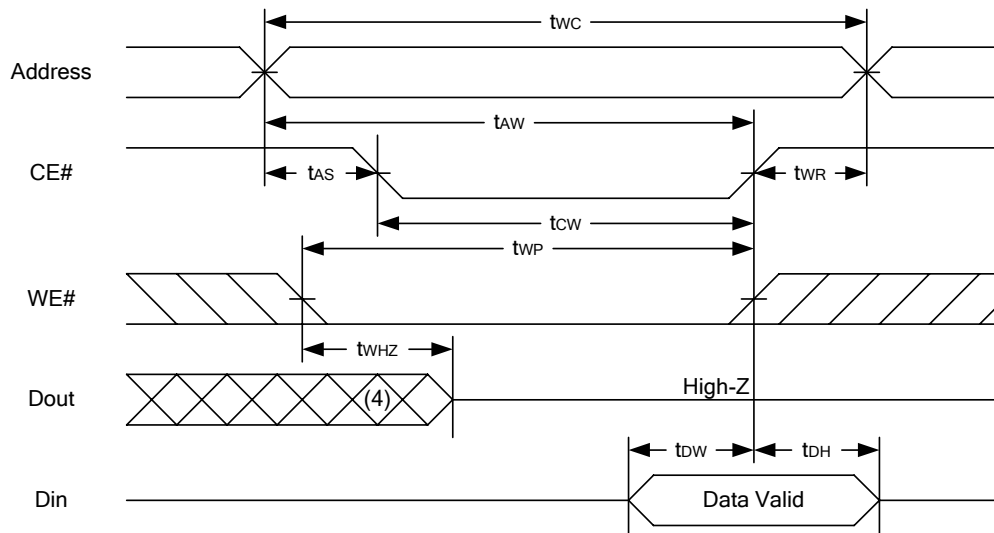

## Notes :

1. WE#, CE# must be high during all address transitions.
2. A write occurs during the overlap of a low CE#, low WE#.
3. During a WE# controlled write cycle with OE# low,  $t_{WP}$  must be greater than  $t_{WHZ} + t_{OW}$  to allow the drivers to turn off and data to be placed on the bus.
4. During this period, I/O pins are in the output state, and input signals must not be applied.
5. If the CE# low transition occurs simultaneously with or after WE# low transition, the outputs remain in a high impedance state.
6.  $t_{OW}$  and  $t_{WHZ}$  are specified with  $C_L = 5\text{pF}$ . Transition is measured  $\pm 500\text{mV}$  from steady state.



## 512K X 8 BIT LOW POWER CMOS SRAM

**DATA RETENTION CHARACTERISTICS**

PARAMETER	SYMBOL	TEST CONDITION	MIN.	TYP.	MAX.	UNIT
V <sub>CC</sub> for Data Retention	V <sub>DR</sub>	CE# ≥ V <sub>CC</sub> - 0.2V	1.5	-	5.5	V
Data Retention Current	I <sub>DR</sub>	V <sub>CC</sub> = 1.5V	-	2	30	μA
		CE# ≥ V <sub>CC</sub> - 0.2V	-LL	2	30	μA
Chip Disable to Data Retention Time	t <sub>CDR</sub>	See Data Retention Waveforms (below)	0	-	-	ns
Recovery Time	t <sub>R</sub>		t <sub>RC</sub> *	-	-	ns

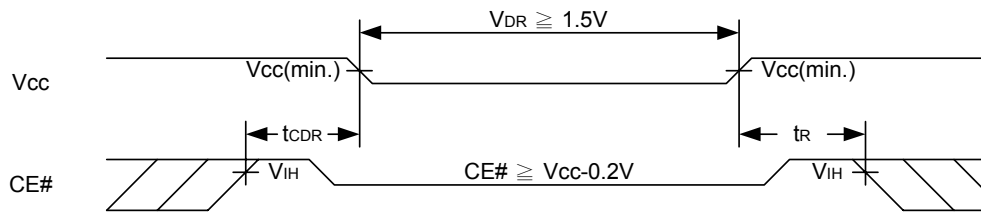
t<sub>RC</sub>\* = Read Cycle Time**DATA RETENTION WAVEFORM**

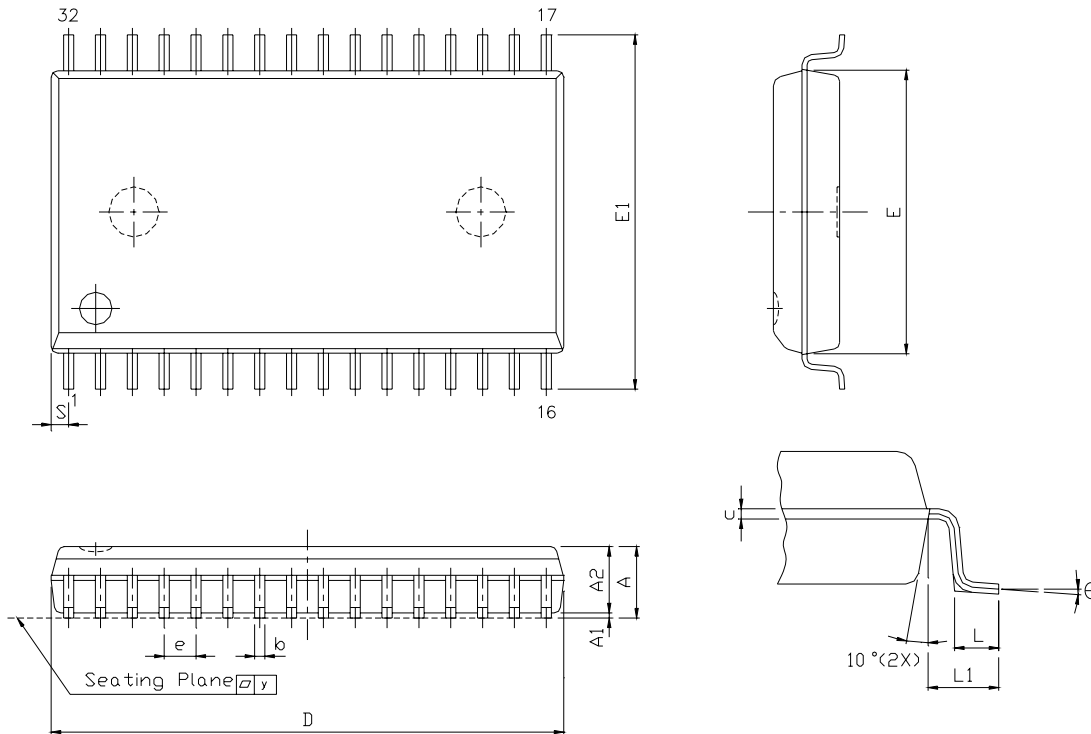

## 512K X 8 BIT LOW POWER CMOS SRAM

**PACKAGE OUTLINE DIMENSION****32 pin 450 mil SOP Package Outline Dimension**

SYM.	UNIT	INCH.(BASE)	MM(REF)
A		0.118 (MAX)	2.997 (MAX)
A1		0.004(MIN)	0.102(MIN)
A2		0.111(MAX)	2.82(MAX)
b		0.016(TYP)	0.406(TYP)
c		0.008(TYP)	0.203(TYP)
D		0.817(MAX)	20.75(MAX)
E		0.445 ±0.005	11.303 ±0.127
E1		0.555 ±0.012	14.097 ±0.305
e		0.050(TYP)	1.270(TYP)
L		0.0347 ±0.008	0.881 ±0.203
L1		0.055 ±0.008	1.397 ±0.203
S		0.026(MAX)	0.660 (MAX)
y		0.004(MAX)	0.101(MAX)
Θ		0° -10°	0° -10°





## 512K X 8 BIT LOW POWER CMOS SRAM

## 32 pin 8mm x 20mm TSOP-I Package Outline Dimension

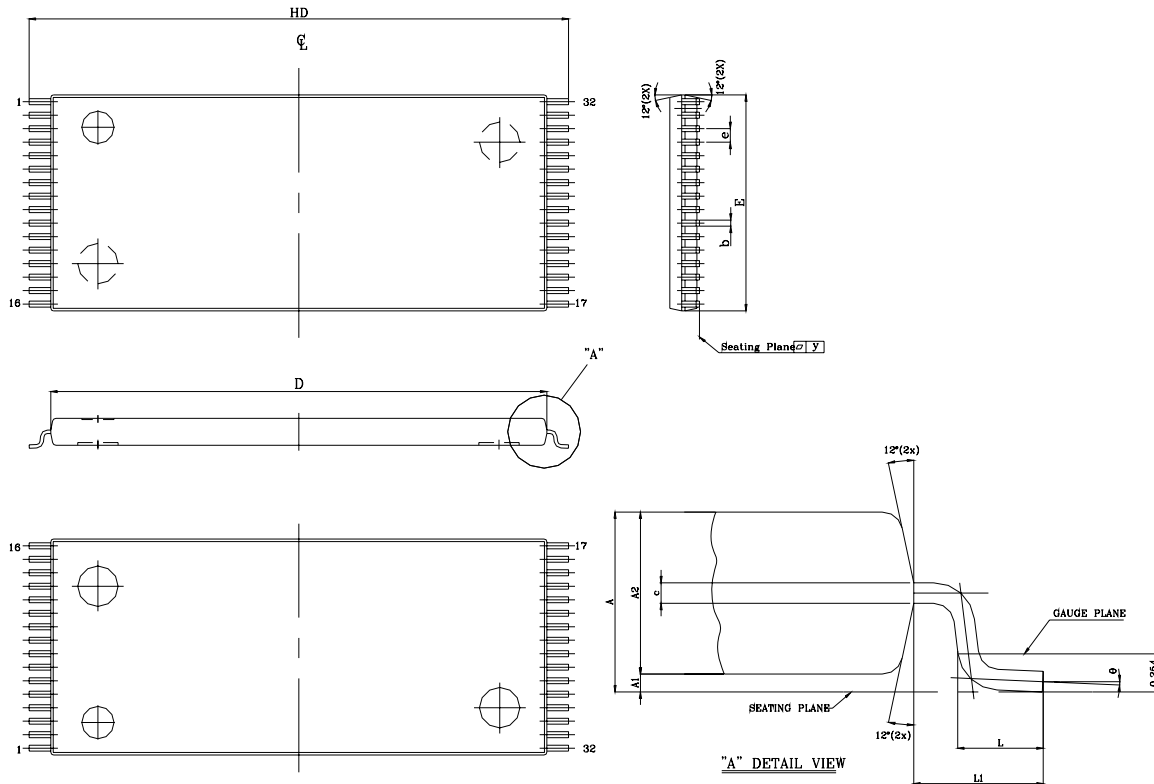

SYM.	UNIT	INCH(BASE)	MM(REF)
A		0.047 (MAX)	1.20 (MAX)
A1		0.004 ±0.002	0.10 ±0.05
A2		0.039 ±0.002	1.00 ±0.05
b		0.008 + 0.002 - 0.001	0.20 + 0.05 - 0.03
c		0.005 (TYP)	0.127 (TYP)
D		0.724 ±0.004	18.40 ±0.10
E		0.315 ±0.004	8.00 ±0.10
e		0.020 (TYP)	0.50 (TYP)
HD		0.787 ±0.008	20.00 ±0.20
L		0.0197 ±0.004	0.50 ±0.10
L1		0.0315 ±0.004	0.08 ±0.10
y		0.003 (MAX)	0.076 (MAX)
θ		0°~5°	0°~5°



## 512K X 8 BIT LOW POWER CMOS SRAM

## 32 pin 8mm x 13.4mm STSOP Package Outline Dimension

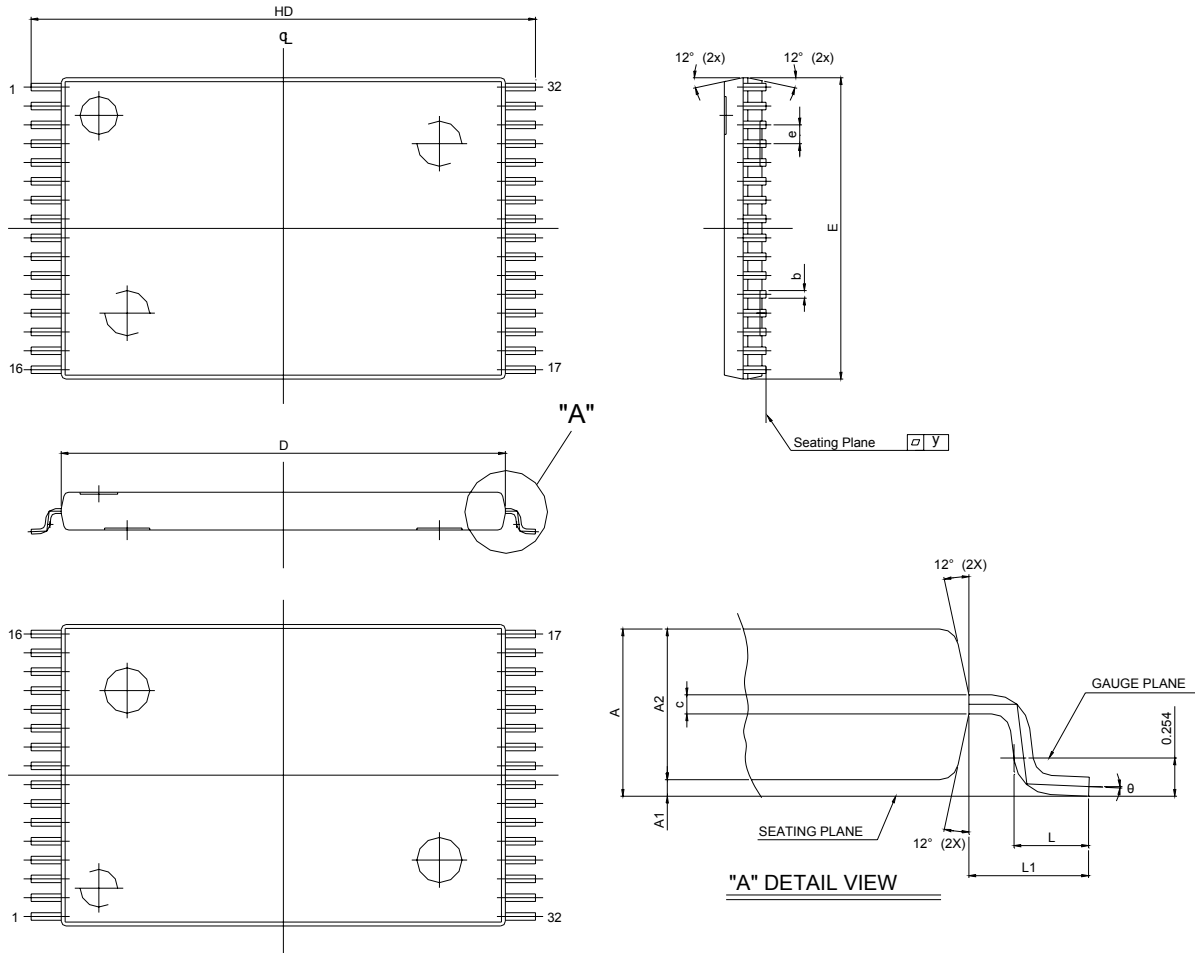

SYM.	UNIT	INCH(BASE)	MM(REF)
A		0.049 (MAX)	1.25 (MAX)
A1		0.005 $\pm$ 0.002	0.130 $\pm$ 0.05
A2		0.039 $\pm$ 0.002	1.00 $\pm$ 0.05
b		0.008 $\pm$ 0.01	0.20 $\pm$ 0.025
c		0.005 (TYP)	0.127 (TYP)
D		0.465 $\pm$ 0.004	11.80 $\pm$ 0.10
E		0.315 $\pm$ 0.004	8.00 $\pm$ 0.10
e		0.020 (TYP)	0.50 (TYP)
HD		0.528 $\pm$ 0.008	13.40 $\pm$ 0.20.
L		0.0197 $\pm$ 0.004	0.50 $\pm$ 0.10
L1		0.0315 $\pm$ 0.004	0.8 $\pm$ 0.10
y		0.003 (MAX)	0.076 (MAX)
$\Theta$		0 $^{\circ}$ ~5 $^{\circ}$	0 $^{\circ}$ ~5 $^{\circ}$



512K X 8 BIT LOW POWER CMOS SRAM

36 ball 6mm x 8mm TFBGA Package Outline Dimension

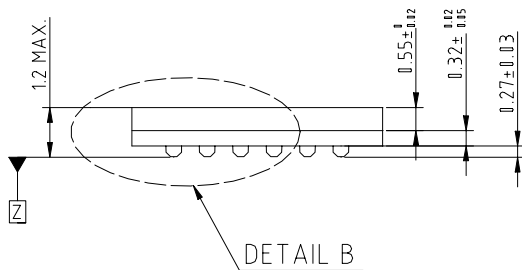
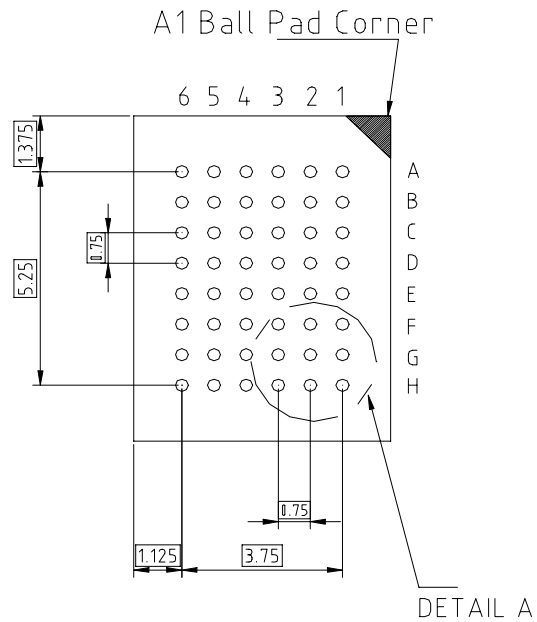
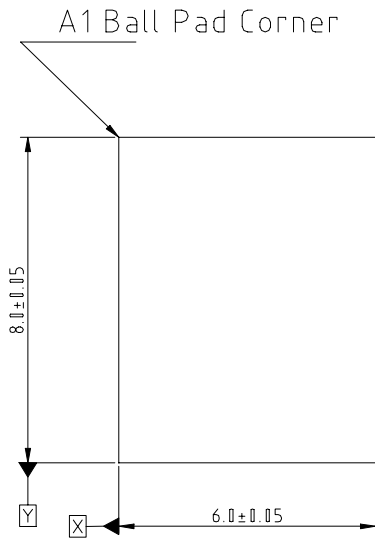

SIDE VIEW

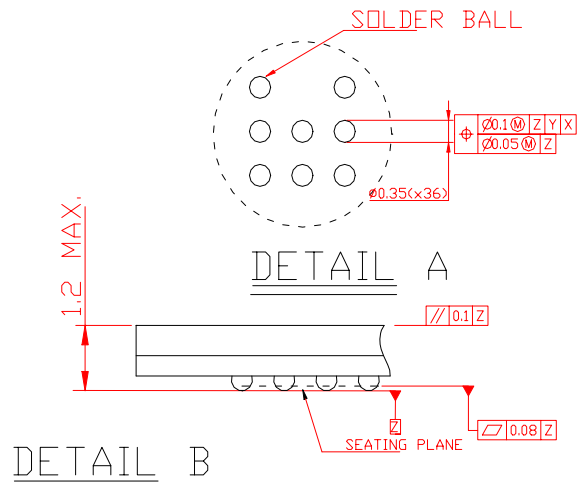

DETAIL B



512K X 8 BIT LOW POWER CMOS SRAM

32-pin 400mil TSOP-II Package Outline Dimension

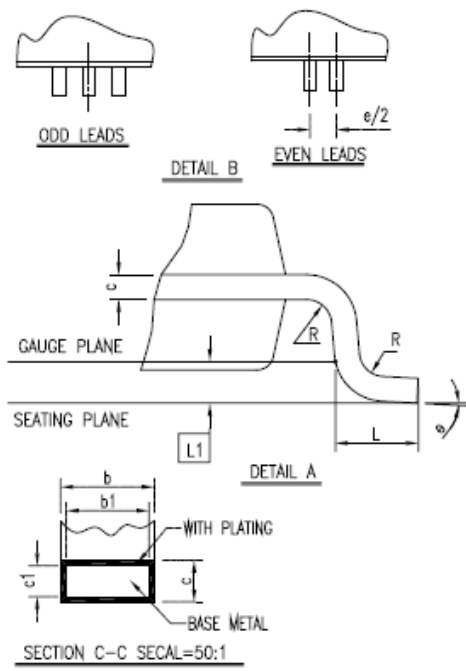
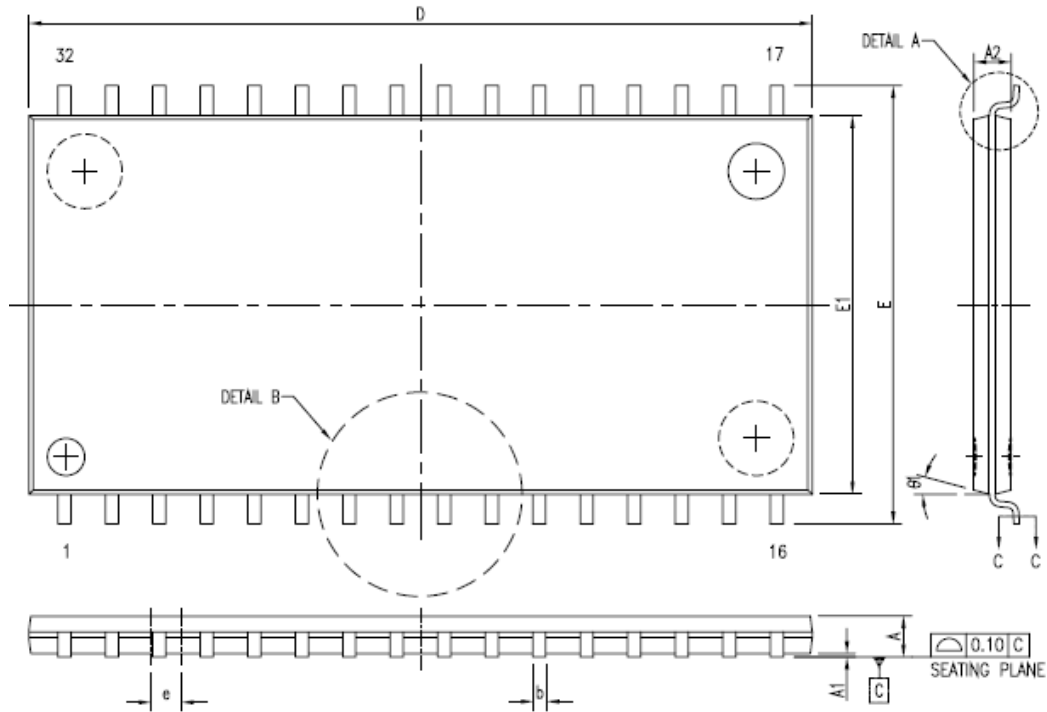

SYMBOL	DIMENSION IN MM			DIMENSION IN INCH		
	MIN.	NOM	MAX.	MIN.	NOM	MAX.
A			1.20			0.047
A1	0.05		0.15	0.002		0.006
A2	0.95	1.00	1.05	0.037	0.039	0.041
c	0.12	---	0.21	0.005	---	0.008
c1	0.12	0.15	0.18	0.005	0.006	0.007
D	20.82	20.95	21.08	0.820	0.825	0.830
E	11.56	11.76	11.96	0.455	0.463	0.471
E1	10.03	10.16	10.29	0.395	0.400	0.405
L	0.40	0.50	0.60	0.016	0.020	0.024
L1	0.25 BASIC			0.010 BASIC		
R	0.11		0.25	0.004		0.010
theta	0		5	0		5
theta1	10	15	20	10	15	20

N	32L
e	1.27 BASIC
b	0.30 --- 0.52
b1	0.30 0.40 0.45
JEDEC	MS-024(BA)



## 512K X 8 BIT LOW POWER CMOS SRAM

## 32 pin 600 mil P-DIP Package Outline Dimension

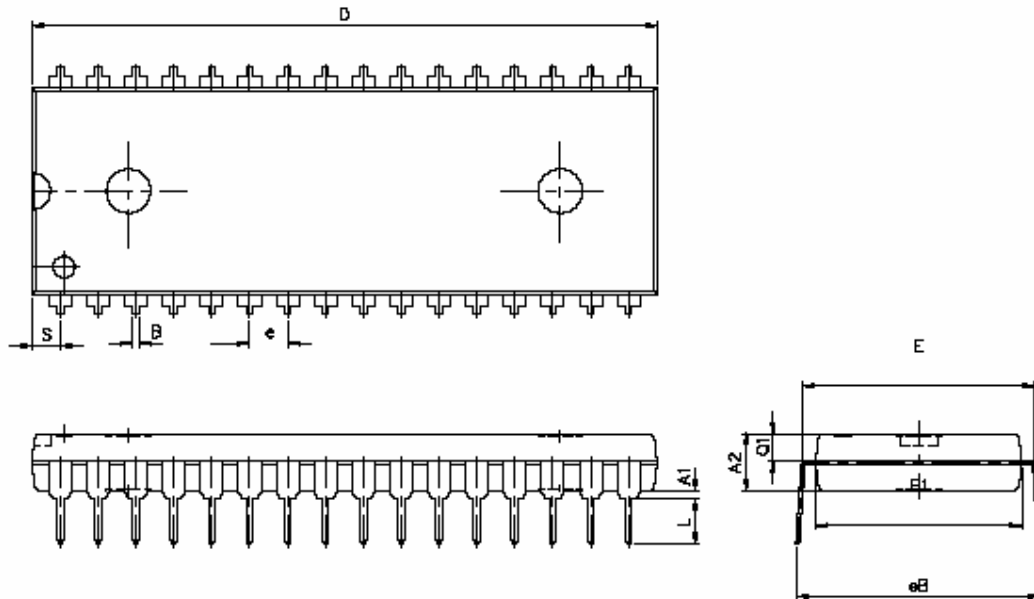

SYM. \ UNIT	INCH(BASE)	MM(REF)
A1	0.001 (MIN)	0.254 (MIN)
A2	$0.150 \pm 0.005$	$3.810 \pm 0.127$
B	$0.018 \pm 0.005$	$0.457 \pm 0.127$
D	$1.650 \pm 0.005$	$41.910 \pm 0.127$
E	$0.600 \pm 0.010$	$15.240 \pm 0.254$
E1	$0.544 \pm 0.004$	$13.818 \pm 0.102$
e	0.100 (TYP)	2.540 (TYP)
eB	$0.640 \pm 0.020$	$16.256 \pm 0.508$
L	$0.130 \pm 0.010$	$3.302 \pm 0.254$
S	$0.075 \pm 0.010$	$1.905 \pm 0.254$
Q1	$0.070 \pm 0.005$	$1.778 \pm 0.127$

Note : D/E1/S dimension do not include mold flash.



## 512K X 8 BIT LOW POWER CMOS SRAM

ORDERING INFORMATION

Alliance	Organization	VCC	Package	Operating Temp	Speed ns
<a href="#">AS6C4008-55PCN</a>	512k x 8	5V	32pin 600mil DIP	Commercial ~ 0° C to 70° C	55
<a href="#">AS6C4008-55SIN</a>	512k x 8	5V	32pin 450mil SOP	Industrial ~ -40°C to 85° C	55
<a href="#">AS6C4008-55TIN</a>	512k x 8	5V	32pin TSOP 1 (8 x 20 mm)	Industrial ~ -40°C to 85° C	55
<a href="#">AS6C4008-55STIN</a>	512k x 8	5V	32pin sTSOP (8 x 13.4 mm)	Industrial ~ -40°C to 85° C	55
<a href="#">AS6C4008-55BIN</a>	512k x 8	5V	36pin TFBGA (6mm x 8mm)	Industrial ~ -40°C to 85° C	55
<a href="#">AS6C4008-55ZIN</a>	512k x 8	5V	32-pin 400mil TSOP 11	Industrial ~ -40°C to 85° C	55

PART NUMBERING SYSTEM

AS6C	4008	- 55	X	X	N
low power SRAM prefix	Device Number 40 = 4M 08 = by 8	Access Time	Package Options: P = 32 pin 600 mil P-DIP S = 32 pin 450 mil SOP T = 32 pin TSOP 1 (8mm x 20 mm) Z = 32-pin 400mil TSOP 11 ST = 32 pin sTSOP (8mm x 13.4 mm) B = 36 pin TFBGA (6mm x 8mm)	Temperature Range: C = Commercial (0°C to +70° C) I = Industrial (-40° to +85° C)	N = Lead Free ROHS Compliant Part