

+3.3V Multiprotocol 3Tx/3Rx Software-Selectable Control Transceivers

ABSOLUTE MAXIMUM RATINGS

(All voltages referenced to GND unless otherwise noted.)

Supply Voltages	
V _{CC}	-0.3V to +4V
V+ (Note 1)	-0.3V to +7V
V- (Note 1)	+0.3V to -7V
V+ to V- (Note 1)	13V
Logic Input Voltages	
M0, M1, M2, DCE/DTE, T_IN	-0.3V to +6V
Logic Output Voltages	
R_OUT	-0.3V to (V _{CC} + 0.3V)
Short-Circuit Duration	Continuous

Transmitter Outputs

T_OUT_	-15V to +15V
Short-Circuit Duration	60s
Receiver Inputs	
R_IN_	-15V to +15V
Continuous Power Dissipation (T _A = +70°C)	
28-Pin SSOP (derate 11.1mW/°C above +70°C)	889mW
Operating Temperature Range	
MAX3171CAI/MAX3173CAI	0°C to +70°C
Storage Temperature Range	-65°C to +150°C
Lead Temperature (soldering, 10s)	+300°C

Note 1: V+ and V- can have maximum magnitudes of 7V, but their absolute difference cannot exceed 13V.

Stresses beyond those listed under "Absolute Maximum Ratings" may cause permanent damage to the device. These are stress ratings only, and functional operation of the device at these or any other conditions beyond those indicated in the operational sections of the specifications is not implied. Exposure to absolute maximum rating conditions for extended periods may affect device reliability.

ELECTRICAL CHARACTERISTICS

(V_{CC} = 3.3V ±5%; C1 = C2 = 1µF, C3 = C4 = C5 = 3.3µF, and T_A = T_{MIN} to T_{MAX}, unless otherwise noted. Typical values are at V_{CC} = +3.3V, T_A = +25°C.) (Note 2)

PARAMETER	SYMBOL	CONDITIONS	MIN	TYP	MAX	UNITS
DC CHARACTERISTICS						
Supply Current (DCE Mode, Digital Inputs = GND or V _{CC} , Transmitter Outputs Static)	I _{CC}	V.11/V.10 modes		220	300	mA
		V.11/V.10 modes (no load)		6	23	
		V.28 mode		24	40	
		V.28 mode (no load)		6	23	
		No-cable mode		2	8	
Internal Power Dissipation	P _D	V.11/V.10 modes (no load)		20		mW
		V.11/V.10 modes (full load)		450		
		V.28 mode (full load)		40		
		No-cable mode		6.6		
V+ Output Voltage	V+	V.11/V.10 modes (no load)	4.4			V
		V.11/V.10 modes (full load)	4.2			
		V.28 mode	5.55			
		No-cable mode	4.6			
V- Output Voltage	V-	V.11/V.10 modes (no load)			-4.0	V
		V.11/V.10 modes (full load)			-3.8	
		V.28 mode			-5.45	
		No-cable mode			-4.2	
Charge-Pump Enable Time		Delay until V+ and V- specifications met		1		ms
LOGIC INPUTS (M0, M1, M2, DCE/DTE, T_IN)						
Input High Voltage	V _{IH}		2.0			V
Input Low Voltage	V _{IL}				0.8	V
Logic Input Current	I _{IH} , I _{IL}	T_IN			±1	µA
		M0, M1, M2, DCE/DTE = V _{CC}			±1	
		M0, M1, M2, DCE/DTE = GND	30	50	100	

+3.3V Multiprotocol 3Tx/3Rx Software-Selectable Control Transceivers

MAX3171/MAX3173

ELECTRICAL CHARACTERISTICS (continued)

(V_{CC} = 3.3V ±5%; C1 = C2 = 1μF, C3 = C4 = C5 = 3.3μF, and T_A = T_{MIN} to T_{MAX}, unless otherwise noted. Typical values are at V_{CC})

PARAMETER	SYMBOL	CONDITIONS	MIN	TYP	MAX	UNITS
LOGIC OUTPUTS (R_OUT)						
Output High Voltage	V _{OH}	I _{SOURCE} = 1.0mA	V _{CC} - 1.0			V
Output Low Voltage	V _{OL}	I _{SINK} = 1.6mA			0.4	V
Rise or Fall Time	t _r , t _f	10% to 90%, Figure 4		15		ns
Output Leakage Current (Receiver Output Three-States)		R_OUT = GND	30	50	100	μA
		R_OUT = V _{CC}			±1	
TRANSMITTER OUTPUTS						
Output Leakage Current	I _Z	-0.25V ≤ V _{OUT} ≤ +0.25V, power off or no-cable mode	-100		100	μA
Data Rate		V.28		240		kbps
		V.10		115		
		V.11		10		Mbps
Receiver Glitch Rejection (MAX3171 only)		Minimum pulse width passed	5			μs
		Minimum pulse width rejected			15	
Receiver Input Resistance	R _{IN}	-10V ≤ V _{AB} ≤ +10V, V _A or V _B grounded, V.11/V.35, no-cable mode	20	40		KΩ
		-15V ≤ V _A ≤ +15V, V.28 mode	3	5	7	
Data Rate	MAX3171	V.10/V.28		64		kbps
		V.11		64		
	MAX3173	V.10/V.28		240		Mbps
		V.11		10		
V.11 TRANSMITTER						
Unloaded Differential Output Voltage	V _{ODO}	R = 1.95kΩ, Figure 1	4.0		6.0	V
Loaded Differential Output Voltage	V _{ODL}	R = 50Ω, Figure 1	0.5 × V _{ODO}			V
Change in Magnitude of Output Differential Voltage	ΔV _{OD}	R = 50Ω, Figure 1			0.2	V
Common-Mode Output Voltage	V _{OC}	R = 50Ω, Figure 1			3.0	V
Change in Magnitude of Output Common-Mode Voltage	ΔV _{OC}	R = 50Ω, Figure 1			0.2	V
Short-Circuit Current	I _{SC}	T_OUTA/B = GND		60	150	mA
Rise or Fall Time	t _r , t _f	10% to 90%, Figure 2		10	25	ns
Transmitter Input to Output	t _{PHL} , t _{PLH}	Figure 2		50	80	ns
Data Skew	t _{PHL} - t _{PLH}	Figure 2		2	10	ns
Output-to-Output Skew	t _{SKEW}	Figure 2		2		ns
Channel-to-Channel Skew				2		ns
V.11 RECEIVER						
Differential Threshold Voltage	V _{TH}	-7V ≤ V _{CM} ≤ +7V	-200	-100	-25	mV
Input Hysteresis	ΔV _{TH}	-7V ≤ V _{CM} ≤ +7V	5	15		mV

+3.3V Multiprotocol 3Tx/3Rx Software-Selectable Control Transceivers

ELECTRICAL CHARACTERISTICS (continued)

($V_{CC} = 3.3V \pm 5\%$; $C1 = C2 = 1\mu F$, $C3 = C4 = C5 = 3.3\mu F$, and $T_A = T_{MIN}$ to T_{MAX} , unless otherwise noted. Typical values are at $V_{CC} = +3.3V$, $T_A = +25^\circ C$.) (Note 2)

PARAMETER	SYMBOL	CONDITIONS	MIN	TYP	MAX	UNITS	
Receiver Input to Output	t_{PHL}, t_{PLH}	MAX3171	5	10	15	μs	
		MAX3173		60	120	ns	
Data Skew	$ t_{PHL} - t_{PLH} $	MAX3171		0.5	4	μs	
		MAX3173		5	16	ns	
V.10 TRANSMITTER							
Unloaded Output Voltage	V_{ODO}	$R_L = 3.9k\Omega$, Figure 3	± 4.0	± 4.4	± 6.0	V	
Loaded Output Voltage Swing	V_{ODL}	$R_L = 450\Omega$, Figure 3	$0.9 \times V_{ODO}$			V	
Short-Circuit Current	I_{SC}	$T_{OUTA} = GND$		± 100	± 150	mA	
Transmitter Rise or Fall Time	t_r, t_f	$R_L = 450\Omega$, $C_L = 100pF$, Figure 3	2			μs	
Transmitter Input to Output	t_{PHL}, t_{PLH}	$R_L = 450\Omega$, $C_L = 100pF$, Figure 3	2			μs	
Data Skew	$ t_{PHL} - t_{PLH} $	$R_L = 450\Omega$, $C_L = 100pF$, Figure 3	50			ns	
V.10 RECEIVER							
Threshold Voltage	V_{TH}		+25	+100	+300	mV	
Input Hysteresis	ΔV_{TH}		15			mV	
Receiver Input to Output	t_{PHL}, t_{PLH}	MAX3171, Figure 4	5	10	15	μs	
		MAX3173, Figure 4	60			120	ns
Data Skew	$ t_{PHL} - t_{PLH} $	MAX3171, Figure 4	0.5			4	μs
		MAX3173, Figure 4	5			16	ns
V.28 TRANSMITTER							
Output Voltage Swing	V_O	All transmitters loaded with $R_L = 3k\Omega$	± 5.0	± 5.4		V	
		No load	± 6.5				
Short-Circuit Current	I_{SC}	$T_{OUTA} = GND$		± 25	± 60	mA	
Output Slew Rate	SR	$R_L = 3k\Omega$, $C_L = 2500pF$, measured from +3V to -3V or from -3V to +3V, Figure 3	4	30		V/ μs	
		$R_L = 7k\Omega$, $C_L = 150pF$, measured from +3V to -3V or from -3V to +3V, Figure 3	6	30			
Transmitter Input to Output	t_{PHL}, t_{PLH}	Figure 3	1			μs	
Data Skew	$ t_{PHL} - t_{PLH} $	Figure 3	100			ns	
V.28 RECEIVER							
Input Threshold Low	V_{IL}		0.8			V	
Input Threshold High	V_{IH}		2.0			V	
Input Hysteresis	V_{HYS}		0.5			V	
Propagation Delay	t_{PLH}, t_{PHL}	MAX3171, Figure 4	5	10	15	μs	
		MAX3173, Figure 4	200				
Data Skew	$ t_{PHL} - t_{PLH} $	MAX3171, Figure 4	0.5		4.0	μs	
		MAX3173, Figure 4	100			ns	

Note 2: V_+ and V_- are also used to supply the MAX3172/MAX3174. The MAX3171/MAX3173 are tested with additional current load on V_+ and V_- to capture the effect of loading from the MAX3172/MAX3174 in all operation modes.

+3.3V Multiprotocol 3Tx/3Rx Software-Selectable Control Transceivers

Typical Operating Characteristics

($V_{CC} = +3.3V$, $C1 = C2 = 1.0\mu F$, $C3 = C4 = C5 = 3.3\mu F$, $T_A = +25^\circ C$, unless otherwise noted.)

MAX3171/MAX3173

V.10/V.11 MODE SUPPLY CURRENT vs. DATA RATE

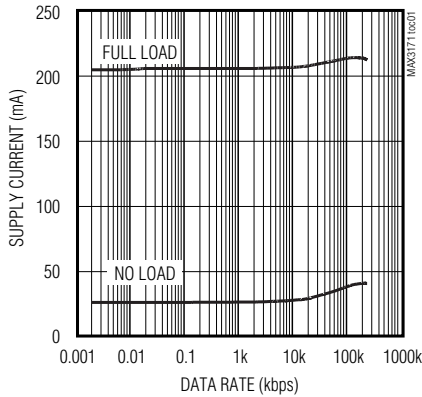

V.28 MODE SUPPLY CURRENT vs. DATA RATE

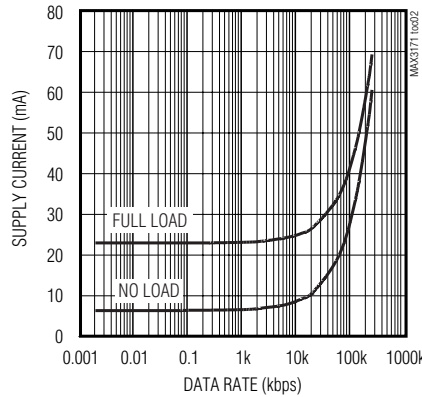

V.11 LOADED DIFFERENTIAL OUTPUT VOLTAGE vs. TEMPERATURE

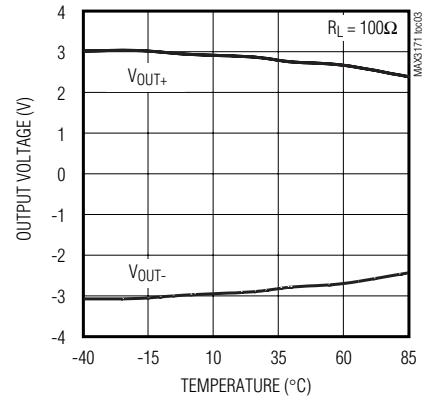

V.28 LOADED OUTPUT VOLTAGE vs. TEMPERATURE

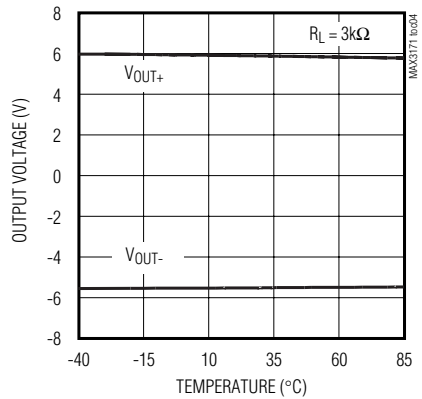

V.10 LOADED OUTPUT VOLTAGE vs. TEMPERATURE

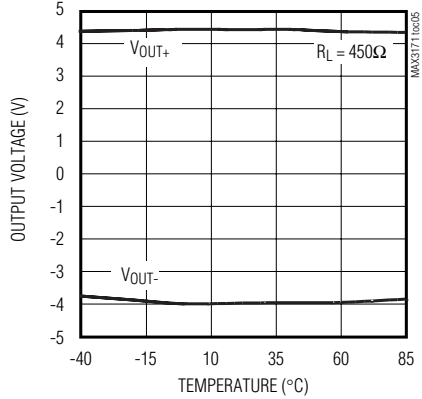

V.10/V.11 RECEIVER INPUT CURRENT vs. INPUT VOLTAGE

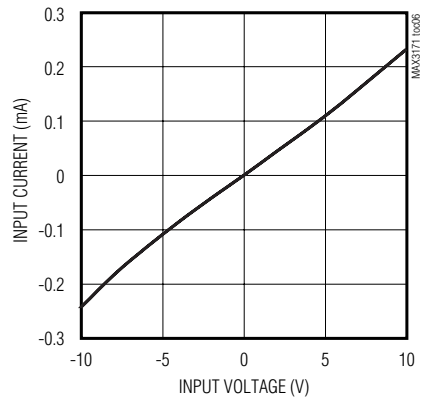

V.28 RECEIVER INPUT CURRENT vs. INPUT VOLTAGE

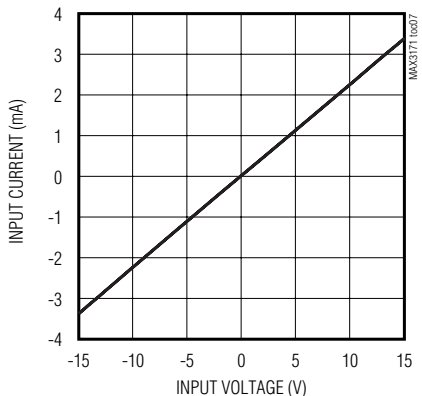

V.28 SLEW RATE vs. LOAD CAPACITANCE

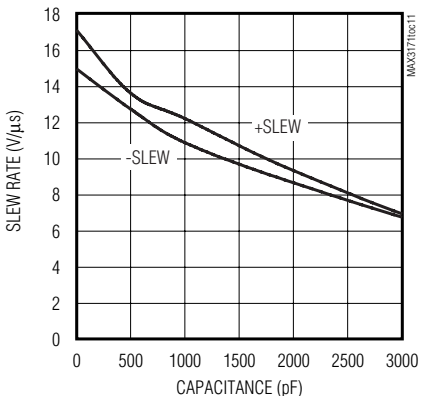

V.10 TRANSMITTER RISE AND FALL TIMES vs. LOAD CAPACITANCE

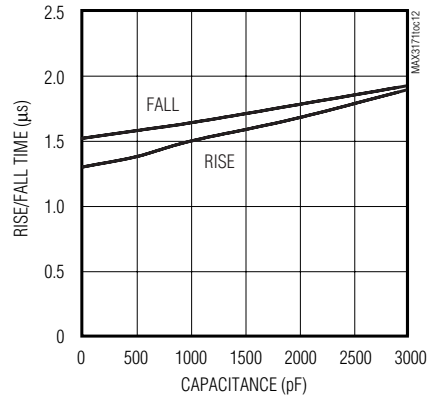

+3.3V Multiprotocol 3Tx/3Rx Software-Selectable Control Transceivers

Typical Operating Characteristics (continued)

(V_{CC} = +3.3V, C1 = C2 = 1.0μF, C3 = C4 = C5 = 3.3μF, T_A = +25°C, unless otherwise noted.)

**MAX3173 LOOPBACK SCOPE PHOTO
V.11 MODE (UNLOADED)**

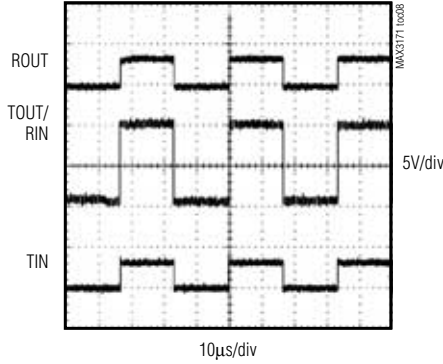

**MAX3171 LOOPBACK SCOPE PHOTO
V.28 MODE (R_L = 3kΩ)**

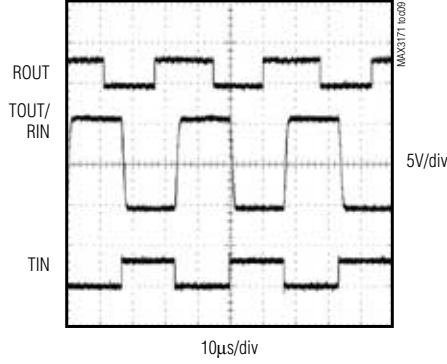

**MAX3173 LOOPBACK SCOPE PHOTO
530A MODE (UNLOADED)**



Test Circuits

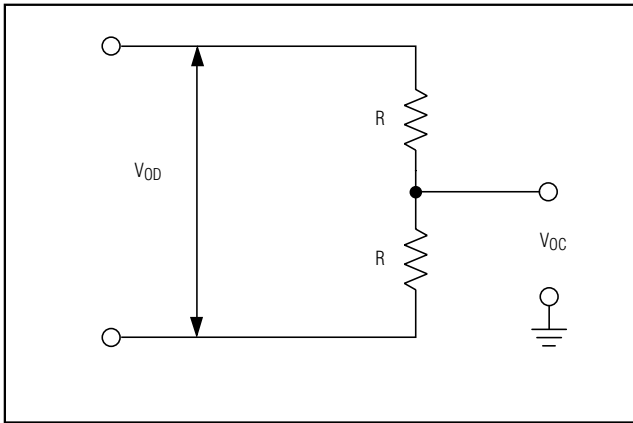

Figure 1. V.11 DC Test Circuit

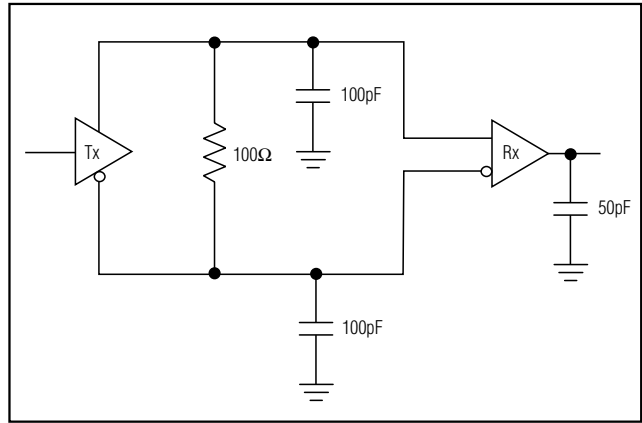

Figure 2. V.11 AC Test Circuit

+3.3V Multiprotocol 3Tx/3Rx Software-Selectable Control Transceiver

Test Circuits (continued)



Figure 3. V.10/V.28 Driver Test Circuit



Figure 4. V.10/V.28 Receiver Test Circuit

Pin Description

PIN	NAME	FUNCTION
1	V+	Positive Supply Generated by the Charge Pump (connect to V+ pin of MAX3172/MAX3174). Bypass V+ to ground with a 3.3μF ceramic capacitor.
2	C2+	Positive Terminal of the Inverting Charge-Pump Capacitor. Connect C2+ to C2- with a 1μF ceramic capacitor.
3	C2-	Negative Terminal of the Inverting Charge-Pump Capacitor. Connect C2+ to C2- with a 1μF ceramic capacitor.
4	V-	Negative Supply Generated by the Charge Pump (connect to V- pin of MAX3172/MAX3174). Bypass V- to ground with a 3.3μF ceramic capacitor.
5, 6, 7	T_IN	Transmitter CMOS Inputs (T1IN, T2IN, T3IN)
8, 9, 10	R_OUT	Receiver CMOS Outputs (R1OUT, R2OUT, R3OUT)
11, 12, 13	M_	Mode Select Inputs (M0, M1, M2). Internally pulled up to V _{CC} . See Table 1 for detailed information.
14	DCE/DTE	DCE/DTE Mode Select Input. Logic level high selects DCE interface; logic level low selects DTE interface. Internally pulled up to V _{CC} .
15, 18	R_INB	Noninverting Receiver Inputs (R3INB, R2INB)
16, 17	R_INA	Inverting Receiver Inputs (R3INA, R2INA)
19	T3OUTB/R1INB	Noninverting Transmitter Output/Noninverting Receiver Input
20	T3OUTA/R1INA	Inverting Transmitter Output/Inverting Receiver Input
21, 23	T_OUTB	Noninverting Transmitter Outputs (T2OUTB, T1OUTB)
22, 24	T_OUTA	Inverting Transmitter Outputs (T2OUTA, T1OUTA)
25	C1-	Negative Terminal of the Voltage-Doubler Charge-Pump Capacitor. Connect C1+ to C1- with a 1μF ceramic capacitor.
26	GND	Ground
27	V _{CC}	+3.3V Supply Voltage (±5%). Bypass V _{CC} to ground with a 3.3μF ceramic capacitor.
28	C1+	Positive Terminal of the Voltage-Doubler Charge-Pump Capacitor. Connect C1+ to C1- with a 1μF ceramic capacitor.

MAX3171/MAX3173

+3.3V Multiprotocol 3Tx/3Rx Software-Selectable Control Transceivers

Table 1. Mode Selection

PROTOCOL	LOGIC INPUTS				TRANSMITTERS			RECEIVERS		
	M2	M1	M0	DCE/DTE	T1	T2	T3	R1	R2	R3
V.11	0	0	0	0	V.11	V.11	Z	V.11	V.11	V.11
RS-530A	0	0	1	0	V.11	V.10	Z	V.11	V.10	V.11
RS-530	0	1	0	0	V.11	V.11	Z	V.11	V.11	V.11
X.21	0	1	1	0	V.11	V.11	Z	V.11	V.11	V.11
V.35	1	0	0	0	V.28	V.28	Z	V.28	V.28	V.28
RS-449/V.36	1	0	1	0	V.11	V.11	Z	V.11	V.11	V.11
V.28/RS-232	1	1	0	0	V.28	V.28	Z	V.28	V.28	V.28
No cable	1	1	1	0	Z	Z	Z	Z	Z	Z
V.11	0	0	0	1	V.11	V.11	V.11	Z	V.11	V.11
RS-530A	0	0	1	1	V.11	V.10	V.11	Z	V.10	V.11
RS-530	0	1	0	1	V.11	V.11	V.11	Z	V.11	V.11
X.21	0	1	1	1	V.11	V.11	V.11	Z	V.11	V.11
V.35	1	0	0	1	V.28	V.28	V.28	Z	V.28	V.28
RS-449/V.36	1	0	1	1	V.11	V.11	V.11	Z	V.11	V.11
V.28/RS-232	1	1	0	1	V.28	V.28	V.28	Z	V.28	V.28
No cable	1	1	1	1	Z	Z	Z	Z	Z	Z

Z = High impedance

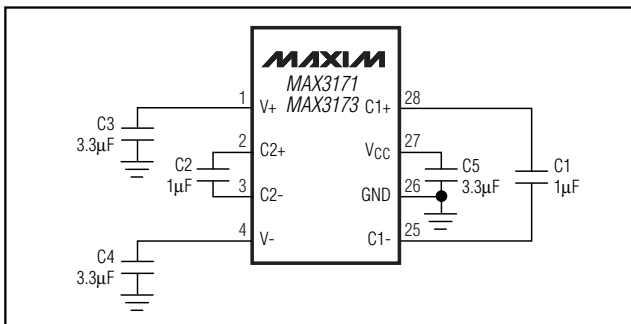

Figure 5. Charge-Pump Connections

Detailed Description

The MAX3171/MAX3173 are three-driver/three-receiver multiprotocol transceivers that operate from a single +3.3V supply. The MAX3171/MAX3173, along with the MAX3170 and MAX3172/MAX3174, form a complete software-selectable DTE or DCE interface port that supports the V.28 (RS-232), V.10/V.11 (RS-449, V.36, EIA-530, EIA-530-A, X.21, RS-423), and V.35 protocols. The MAX3171/MAX3173 carry the control signals, while the MAX3170 transceiver carries the high-speed clock and data signals. The MAX3172/MAX3174 provide termination for the clock and data signals and have an extra transceiver for applications requiring four transceivers for control handshaking.

The MAX3171/MAX3173 feature a 2mA no-cable mode, true fail-safe operation, and thermal shutdown circuitry. Thermal shutdown protects the drivers against excessive power dissipation. When activated, the thermal shutdown circuitry places the driver outputs into a high-impedance state.

Mode Selection

The state of mode select pins M0, M1, and M2 determines which serial interface protocol is selected (Table 1). The state of the DCE/DTE input determines whether the transceivers will be configured as a $\overline{\text{DTE}}$ serial port or a DCE serial port. When the DCE/DTE input is logic HIGH, driver T3 is activated and receiver R1 is disabled. When the DCE/DTE input is logic LOW, driver T3 is disabled and receiver R1 is activated. M0, M1, M2, and DCE/DTE are internally pulled up to VCC to ensure logic HIGH if left unconnected.

The MAX3171/MAX3173's mode can be selected through software control of the M0, M1, M2, and DCE/DTE inputs. Alternatively, the mode can be selected by shorting the appropriate combination of mode control inputs to GND (the inputs left floating will be internally pulled up to VCC). If the M0, M1, and M2 mode inputs are all unconnected, the MAX3171/MAX3173 will enter no-cable mode.

+3.3V Multiprotocol 3Tx/3Rx Software-Selectable Control Transceiver

MAX3171/MAX3173

No-Cable Mode

The MAX3171/MAX3173 enter no-cable mode when the mode select pins are left unconnected or tied HIGH ($M0 = M1 = M2 = 1$). In this mode, the multiprotocol drivers and receivers are disabled and the supply current is less than 8mA. The receiver outputs enter a high-impedance state in no-cable mode, which allows these output lines to be shared with other receivers (the receiver outputs have an internal pullup resistor to pull the outputs HIGH if not driven). Also, in no-cable mode, the transmitter outputs enter a high-impedance state, so these output lines can be shared with other devices.

Dual Charge-Pump Voltage Converter

The MAX3171/MAX3173 internal power supply consists of a regulated dual charge pump that provides positive and negative output voltages from a +3.3V supply. The charge pump operates in discontinuous mode: If the output voltage is less than the regulated voltage, the charge pump is enabled; if the output voltage exceeds the regulated voltage, the charge pump is disabled. Each charge pump requires a flying capacitor (C1, C2) and a reservoir capacitor (C3, C4) to generate the V+ and V- supplies. See Figure 5 for charge-pump connections.

The charge pump is designed to supply V+ and V- power to the MAX3172/MAX3174 in addition to the MAX3171/MAX3173 internal transceivers. Connect the MAX3172/MAX3174 V+ and V- terminals to the MAX3171/MAX3173 V+ and V- terminals, respectively.

Fail-Safe

The MAX3171/MAX3173 guarantee a logic HIGH receiver output when the receiver inputs are shorted or open, or when they are connected to a terminated transmission line with drivers disabled. The V.11 receiver threshold is set between -25mV and -200mV to guarantee fail-safe operation. If the differential receiver input voltage ($B - A$) is $\geq -25\text{mV}$, R_OUT is logic HIGH. In the case of a terminated bus with all transmitters disabled, the receiver's differential input voltage is pulled to 0 by the termination. With the MAX3171/MAX3173 receiver thresholds, this results in R_OUT logic HIGH with a 25mV (min) noise margin.

The V.10 receiver threshold is set between +25mV and +300mV. If the V.10 receiver input voltage is $\leq +25\text{mV}$, R_OUT is logic HIGH. The V.28 receiver threshold is set between 0.8V and 2.0V. If the receiver input voltage is $\leq 0.8\text{V}$, R_OUT is logic HIGH. In the case of a terminated bus with transmitters disabled, the V.10/V.28 receiver's input voltage is pulled to ground by the termination. With the MAX3172/MAX3174 receiver thresholds, this results in R_OUT logic HIGH.

Applications Information

Capacitor Selection

The capacitors used for the charge pumps, as well as the supply bypassing, should have a low-ESR and low-temperature coefficient. Multilayer ceramic capacitors with an X7R dielectric offer the best combination of performance, size, and cost. The flying capacitors (C1, C2) should have a value of $1\mu\text{F}$, while the reservoir capacitors (C3, C4) and bypass capacitor (C5) should have a minimum value of $3.3\mu\text{F}$ (Figure 5). To reduce the ripple present on the transmitter outputs, capacitors C3, C4, and C5 can be increased. Do not increase the value of C1 and C2.

Local Loopback Control Signal

For applications that require the use of local loopback (LL) signal routing, an extra transceiver is available for use on the MAX3172/MAX3174 multiprotocol termination network device.

Cable-Selectable Mode

Figure 6 shows a cable-selectable multiprotocol interface. The mode control lines (M0, M1, M2, and DCE/DTE) are wired to the DB-25 connector. To select the serial interface mode, the appropriate combinations of M0, M1, M2, and DCE/DTE are grounded within the cable wiring. The control lines that are not grounded are pulled high by the internal pullups on the MAX3170. The serial interface protocol of the MAX3171/MAX3173 (MAX3170 and MAX3172/MAX3174) is now selected based on the cable connected to the DB-25 interface.

V.11 (RS-422) Interface

As shown in Figure 7, the V.11 protocol is a fully balanced differential interface. The V.11 driver generates $\pm 2\text{V}$ (min) between nodes A and B when 100Ω (min) resistance is presented at the load. The V.11 receiver is sensitive to $\pm 200\text{mV}$ differential signals at the receiver inputs A' and B'. The V.11 receiver input must comply with the impedance curve of Figure 8 and reject common-mode signals up to $\pm 7\text{V}$ developed across the cable (referenced from C to C' in Figure 7).

The MAX3171/MAX3173 V.11 mode receiver has a differential threshold between -200mV and -25mV to ensure that the receiver has proper fail-safe operation (see *Fail-Safe*). To aid in rejecting system noise, the MAX3171/MAX3173 V.11 receiver has a 15mV (typ) hysteresis. Switch S3 in Figure 9 is open in V.11 mode to disable the V.28 $5\text{k}\Omega$ termination at the inverting receiver input. Because the control signals are slow (64kbps), 100Ω termination resistance is generally not required for the MAX3171/MAX3173.

+3.3V Multiprotocol 3Tx/3Rx Software-Selectable Control Transceivers

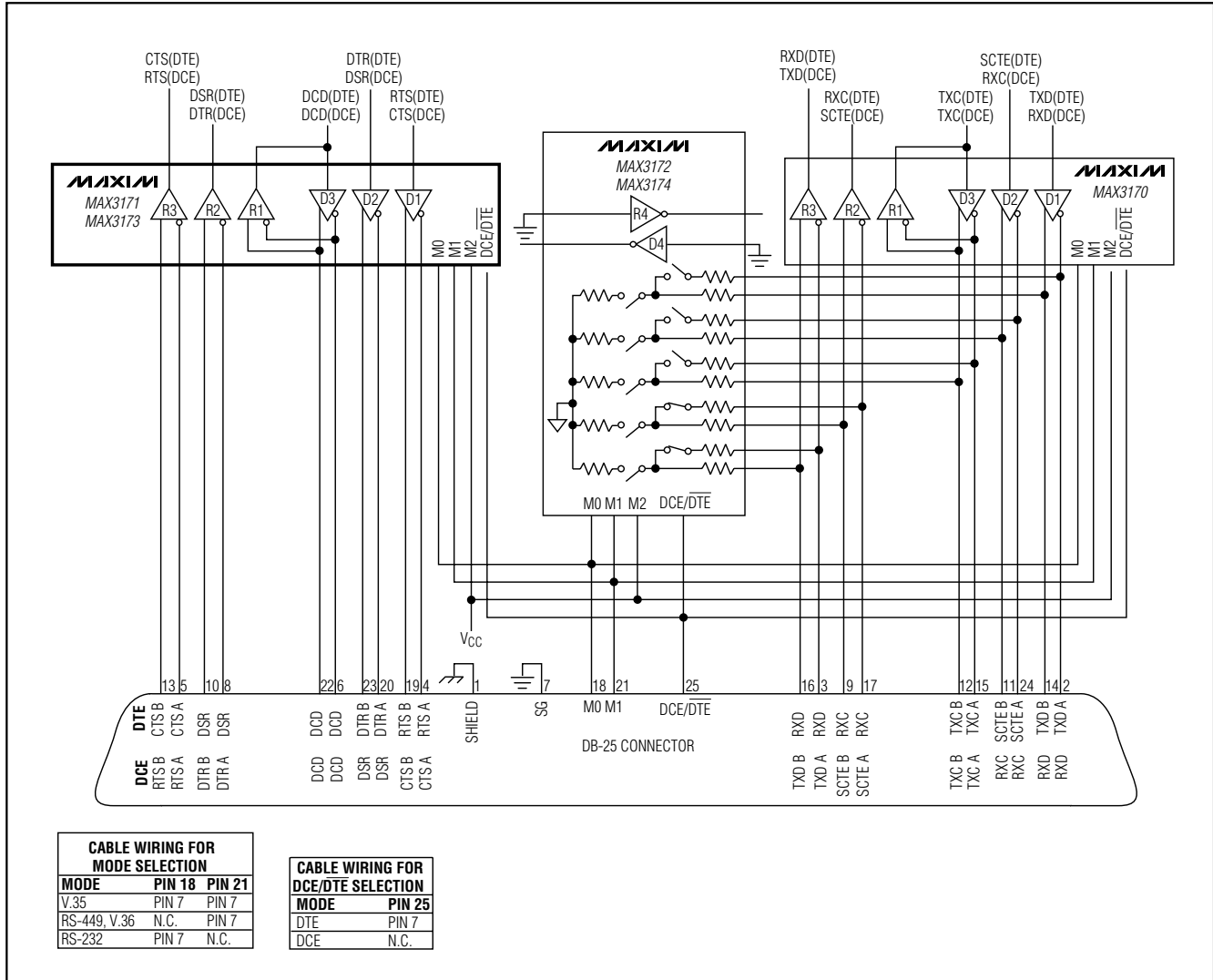

Figure 6. Cable-Selectable Multiprotocol DCE/DTE Port



Figure 7. Typical V.11 Interface

V.10 Interface

The V.10 interface (Figure 10) is an unbalanced single-ended interface capable of driving a 450Ω load. The V.10 driver generates a ±4V (min) V_{ODD} voltage across A' and C' when unloaded and a minimum of $\pm 0.9 \times V_{ODD}$ voltage with a 450Ω load. The V.10 receiver input trip threshold is defined between +300mV and -300mV with the input impedance characteristic shown in Figure 8.

The MAX3171/MAX3173 V.10 mode receiver has a threshold between +25mV and +300mV to ensure that the receiver has proper fail-safe operation (see *Fail-*

+3.3V Multiprotocol 3Tx/3Rx Software-Selectable Control Transceiver

MAX3171/MAX3173

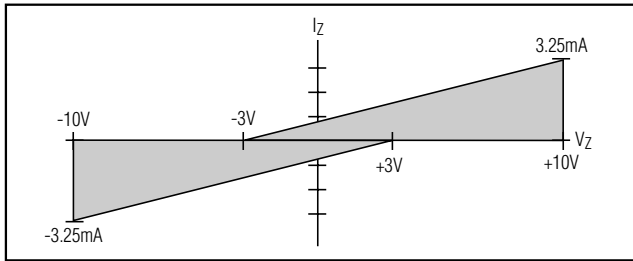

Figure 8. Receiver Input Impedance Curve

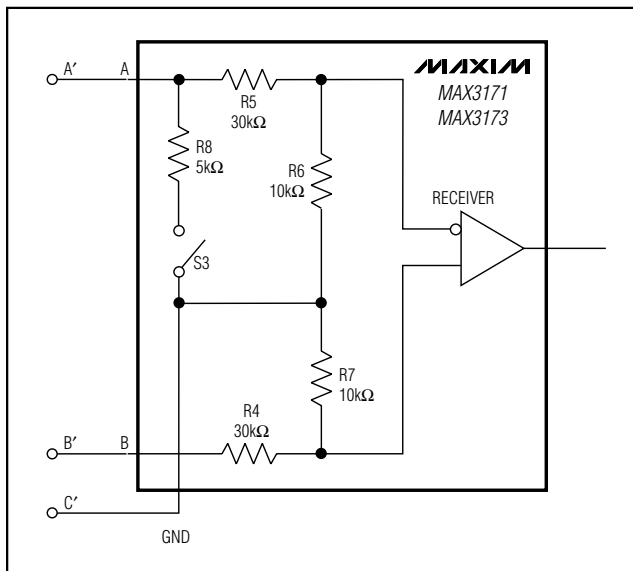

Figure 9. V.11 Termination and Internal Resistance Networks

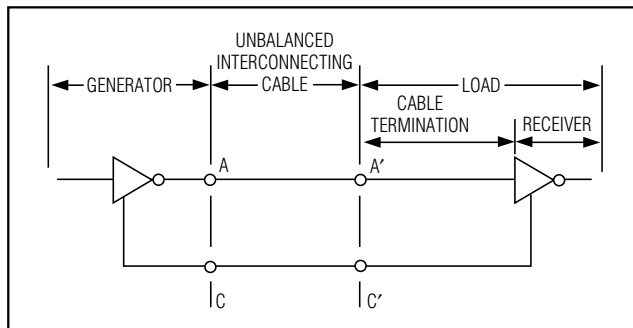

Figure 10. Typical V.10/V.28 Interface

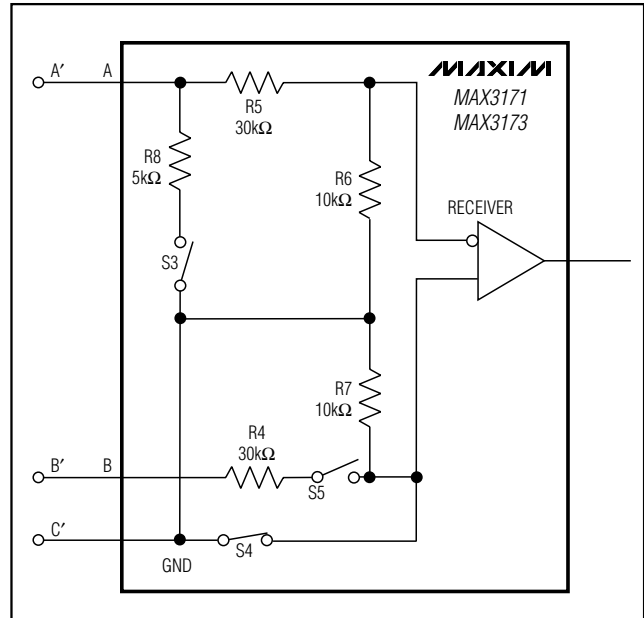

Figure 11. V.10 Internal Resistance Network

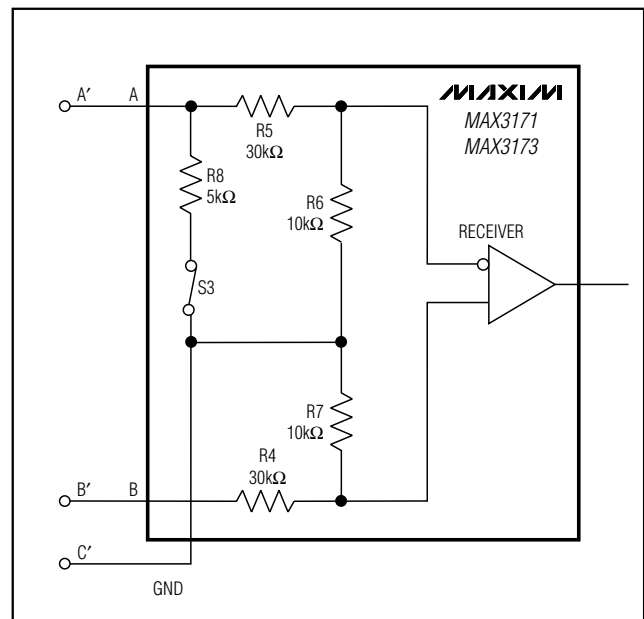

Figure 12. V.28 Termination and Internal Resistance Networks

+3.3V Multiprotocol 3Tx/3Rx Software-Selectable Control Transceivers

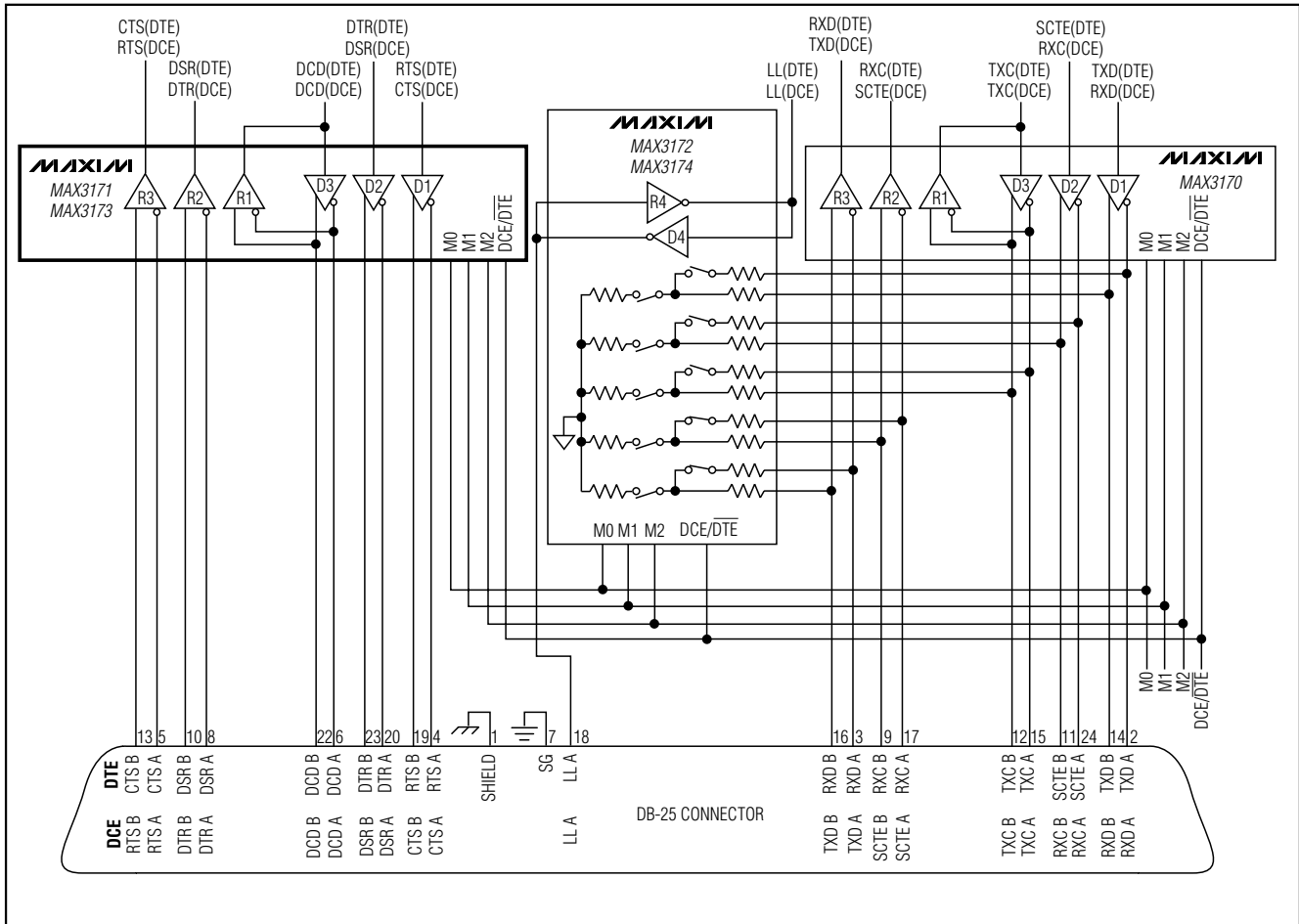

Figure 13. Multiprotocol DCE/DTE Port

Safe). To aid in rejecting system noise, the MAX3171/MAX3173 V.10 receiver has 15mV (typ) hysteresis. Switch S3 in Figure 11 is open in V.10 mode to disable the 5kΩ V.28 termination at the receiver input. Switch S4 is closed, and switch S5 is open to internally ground the receiver B input.

V.28 Interface

The V.28 interface is an unbalanced single-ended interface (Figure 12). The V.28 generator provides ±5V (min) across the load impedance between A' and C'. The V.28 standard specifies input trip points at ±3V.

The MAX3171/MAX3173 V.28 mode receiver has a threshold between +0.8V and +2.0V to ensure that the receiver has proper fail-safe operation (see *Fail-Safe*). To aid in rejecting system noise, the MAX3171/MAX3173 V.28 receiver has a 500mV (typ) hysteresis. Switch S3 in

Figure 12 is closed in V.28 mode to enable the 5kΩ V.28 termination at the receiver input.

Receiver Glitch Rejection

To facilitate operation in an unterminated or otherwise noisy system, the MAX3171 features 10μs of receiver input glitch rejection in V.10, V.11, and V.28 modes. The glitch rejection circuitry blocks the reception of high-frequency noise ($t_B < 5\mu s$) while receiving a low-frequency signal ($t_B > 15\mu s$), allowing glitch-free operation in unterminated systems at up to 64kbps. The MAX3173 does not have this feature and can be operated at data rates up to 240kbps if properly terminated.

DTE vs. DCE Operation

Figure 13 shows a DCE or DTE controller-selectable interface. The DCE/DTE input switches the port's mode of operation. A logic high selects DCE, which enables

+3.3V Multiprotocol 3Tx/3Rx Software-Selectable Control Transceiver

MAX3171/MAX3173

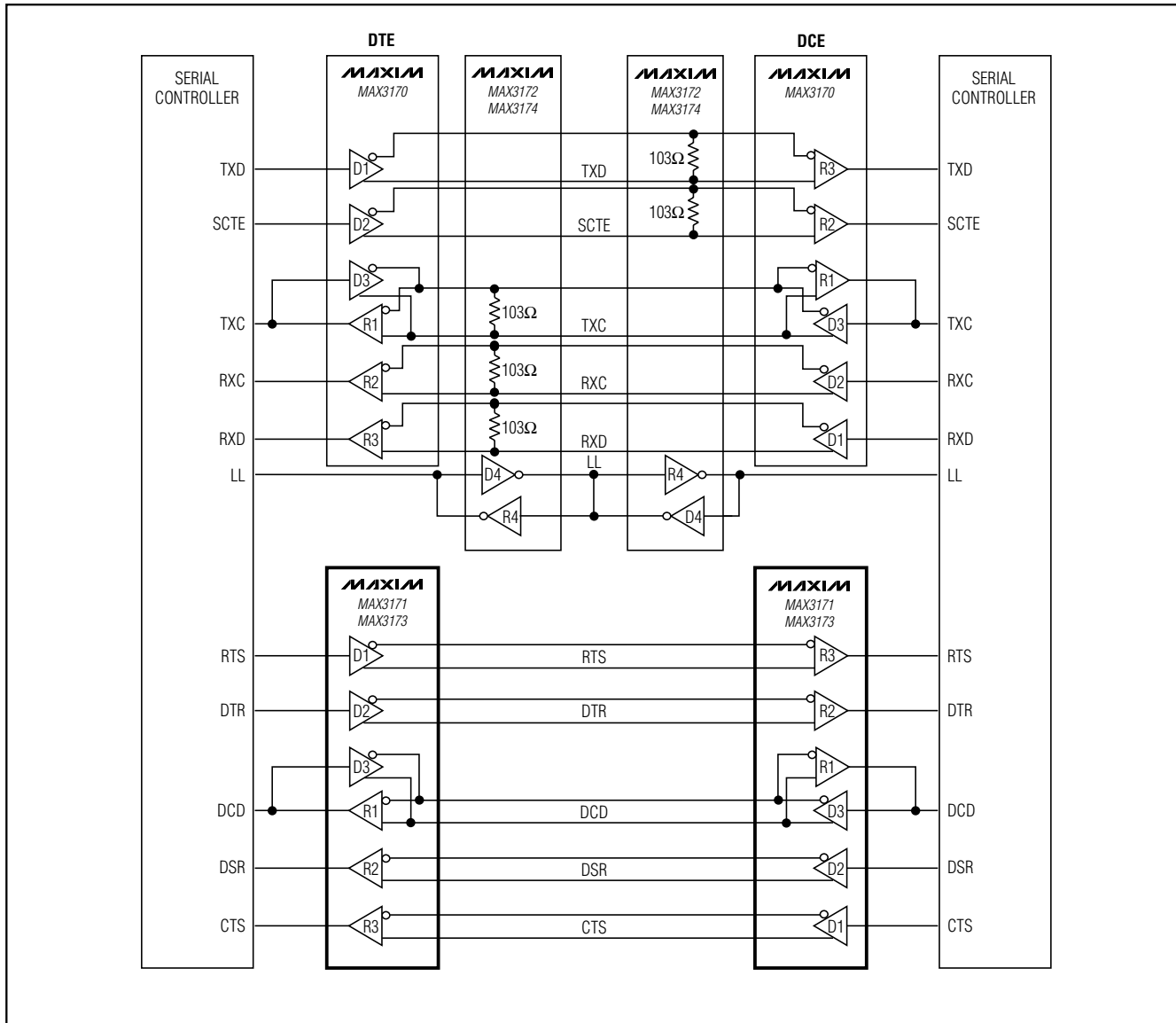

Figure 14. DCE-to-DTE X.21 Interface

driver 3 on the MAX3171/MAX3173, driver 3 on the MAX3170, and driver 4 on the MAX3172/MAX3174. A logic low selects DTE, which enables receiver 1 on the MAX3171/MAX3173, receiver 1 on the MAX3170, and receiver 4 on the MAX3172/MAX3174.

This application requires only one DB-25 connector. See Figure 13 for complete signal routing in DCE and DTE modes. For example, driver 3 routes the DCD (DCE) signal to pins 22 and 6 in DCE mode, while in DTE mode, receiver 1 routes pins 22 and 6 to DCD (DTE).

Complete Multiprotocol X.21 Interface

Figure 14 shows a complete DCE-to-DTE interface operating in X.21 mode. The MAX3171/MAX3173 generate the control signals, and the MAX3170 is used to generate the clock and data signals. The MAX3172/MAX3174 generate local loopback and are used to terminate the clock and data signals to support the V.11 protocol for cable termination. The control signals do not need external termination.

+3.3V Multiprotocol 3Tx/3Rx Software-Selectable Control Transceivers

Compliance Testing

A European Standard EN 45001 test report is available for the MAX3170–MAX3174 chipset. A copy of the test report will be available from Maxim.

Chip Information

TRANSISTOR COUNT: 1763
PROCESS: BiCMOS

Pin Configuration



+3.3V Multiprotocol 3Tx/3Rx Software-Selectable Control Transceiver

Package Information

MAX3171/MAX3173

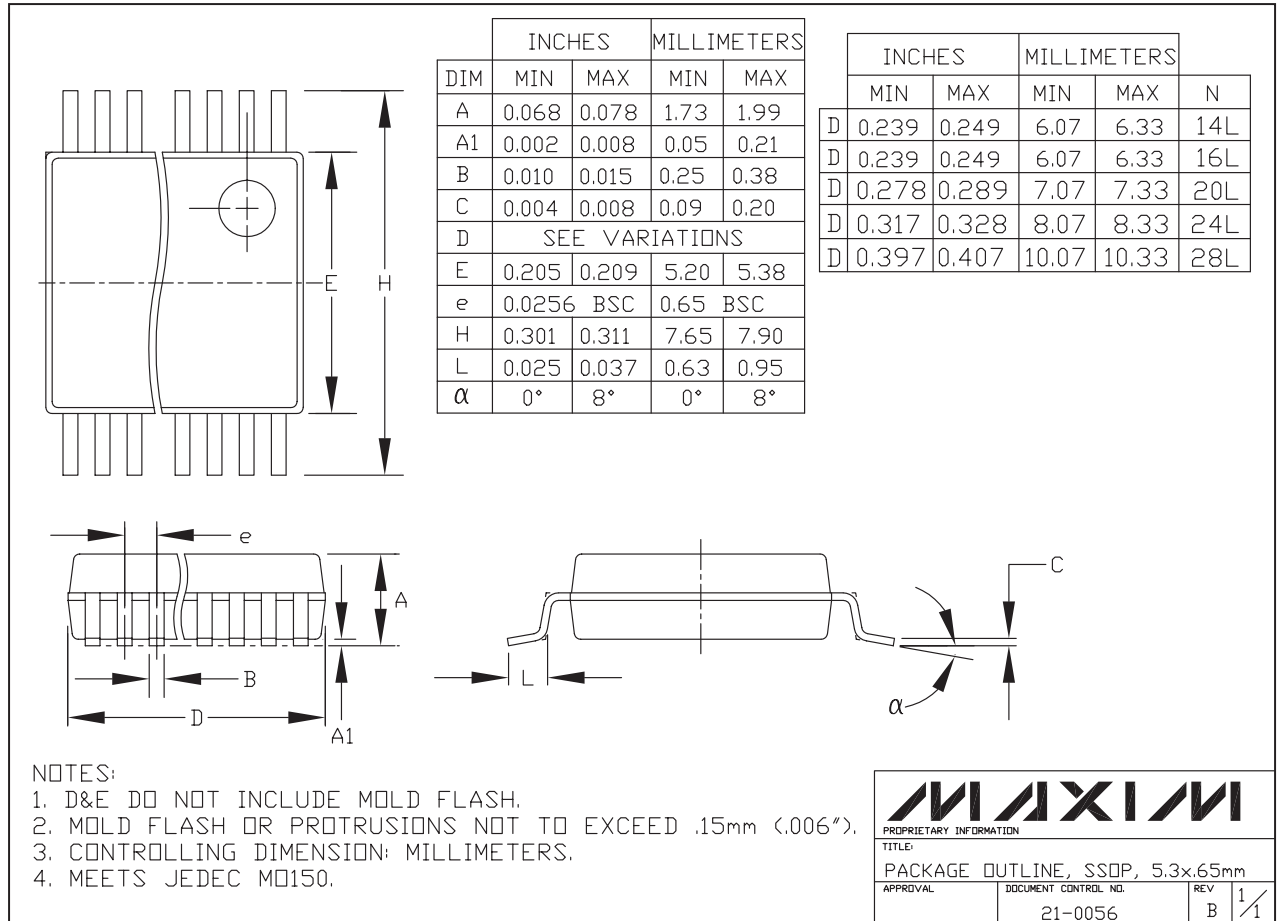

Maxim cannot assume responsibility for use of any circuitry other than circuitry entirely embodied in a Maxim product. No circuit patent licenses are implied. Maxim reserves the right to change the circuitry and specifications without notice at any time.

Maxim Integrated Products, 120 San Gabriel Drive, Sunnyvale, CA 94086 408-737-7600 _____ 15