



MAX1564 Evaluation Kit

Evaluates: MAX1564

General Description

The MAX1564 evaluation kit (EV kit) is a fully assembled and tested surface-mount circuit board that demonstrates the MAX1564 triple 1.2A USB switch. The EV kit operates from a +2.7V to +5.5V input power supply and is capable of sourcing up to 1.2A from each output. The MAX1564 features an adjustable current-limit and auto-restart function for overload and short-circuit protection. A 20ms fault-blanking time prevents erroneous faults caused by load transients and capacitive loads. The MAX1564 is assembled in the space-saving 16-pin, 4mm x 4mm thin QFN package.

Component List

DESIGNATION	QTY	DESCRIPTION
C1	1	0.1 μ F \pm 10%, 16V X5R ceramic capacitor (0603) Taiyo Yuden EMK107BJ104KA or equivalent
C2, C3, C4	3	1 μ F \pm 10%, 10V X5R ceramic capacitors (0603) TDK C1608X5R1A105K or equivalent
JU1, JU2, JU3	3	3-pin headers
R1	1	26.1k Ω \pm 1% resistor (0603)
R2, R3, R4, R7, R8, R9	6	100k Ω \pm 5% resistors (0603)
R5, R6	2	Not installed (0603)
U1	1	MAX1564ETE (16-pin TQFN)
None	3	Shunts
None	1	MAX1564 EV kit PC board

Quick Start

The MAX1564 EV kit is fully assembled and tested. Follow these steps to verify board operation:

- 1) Preset the power supply to 2.7V and turn off the power supply. **Do not turn the power supply on until all connections are made.**
- 2) Verify on the MAX1564 EV kit that there is a shunt across pins 1 and 2 of JU1, JU2, and JU3 to enable all three channels of the device.
- 3) Connect the positive lead of the power supply to the VIN pad on the EV kit and the negative lead of the power supply to the GND pad on the EV kit.
- 4) Connect the positive lead of the DMM to the OUTA pad on the EV kit and the negative lead of the DMM

Features

- ◆ Tiny 16-Pin (4mm x 4mm) Thin QFN Package
- ◆ Reverse Current Blocking
- ◆ Programmable Current-Limit
- ◆ Autorestart When Fault is Removed
- ◆ 12% Accurate Current-Limit
- ◆ Up to 1.2A Load Current for Each Output
- ◆ Thermal Overload Protection
- ◆ Built-In 20ms Fault Blanking
- ◆ Compliant to All USB Specifications
- ◆ 2.7V to 5.5V Input Supply Range
- ◆ Independent Fault Indicator Outputs
- ◆ Active-High/Active-Low Select Pin
- ◆ \pm 15kV ESD Protection (With Capacitors)
- ◆ UL Listing Pending
- ◆ Fully Assembled and Tested

Ordering Information

PART	TEMP RANGE	IC PACKAGE
MAX1564EVKIT	0°C to +70°C	16 TQFN (4mm x 4mm)

to the GNDA pad on the EV kit to measure the output voltage at switch channel A.

- 5) Turn on the power supply and sweep the input voltage from 2.7V to 5.5V.
- 6) Verify that the output voltage tracks the voltage at VIN over the entire input range.
- 7) Set the power supply to 5V.
- 8) Connect the 1.2A load between the VOUTA and GNDA pads on the EV kit.
- 9) Verify that the output voltage is approximately 5V.
- 10) Repeat these steps for the OUTB and OUTC outputs.

MAX1564 Evaluation Kit

Detailed Description

FLTA, FLTB, and FLTC

The MAX1564 provides an independent open-drain fault output (\overline{FLT}_-) for each switch. In the MAX1564 EV kit, the \overline{FLT}_- outputs are connected to IN_- through a 100k Ω pullup resistor. \overline{FLT}_- asserts low when any of the following conditions occur:

- The input voltage is below the UVLO threshold.
- The switch junction temperature exceeds the +160°C thermal-shutdown temperature limit.
- The switch is in current-limit or short-circuit current-limit mode after the fault-blanking period (20ms) expires.
- The reverse current condition exists after the fault-blanking period expires.

The \overline{FLT}_- output goes high impedance after a 20ms delay once the fault condition is removed. Refer to the MAX1564 IC data sheet for more details on fault protection and fault blanking.

Shutdown (SEL, ONA, ONB, ONC)

SEL sets the active polarity of the logic inputs of the MAX1564. R5 and R6 are available to set the input to SEL. R5 comes shorted to connect SEL to VIN. To connect SEL to GND, cut the short on R5 and short R6.

JU1, JU2, and JU3 are available for ON_ control (Table 1). Connect a shunt across JU1 to connect ONA to VIN, connect a shunt across JU2 to connect ONB to VIN, and connect a shunt across JU3 to connect ONC to VIN.

Remove the shunts to connect the respective ON_ to GND. With the default setting for SEL (R5 shorted), installing the shunt enables the respective OUT_. The output of a disabled switch enters a high-impedance state.

Setting the Current Limit

The current-limit for the MAX1564 is user programmable using the SETI input. Connect a resistor from SETI to GND (R1) to set the current limit. The value for R1 is calculated as:

$$I_{LIMIT} = 1.37A \times 26k\Omega / R1$$

R1 must be between 26k Ω and 60k Ω .

Input Supply Considerations

When evaluating the MAX1564 EV kit on the bench, take care to use short input leads (< 6in). The inductance of longer leads can cause oscillations during an overload or short circuit that exceed the absolute maximum rating (6V) on the input and can damage the IC. If short leads cannot be used, add a bulk capacitor to the input to eliminate these voltage spikes. This capacitor is not necessary in the final application.

Jumper Settings

Table 1. Jumper JU1, JU2, JU3 Functions (ON_ Control)

SHUNT LOCATION	ON_ PIN	OPERATION
On	Connected to VIN	Normal operation
Off	Connect to GND	Shutdown mode

Component Suppliers

SUPPLIER	COMPONENT	WEBSITE
Taiyo Yuden	Capacitors	www.t-yuden.com
TDK	Capacitors	www.component.tdk.com
Vishay	Resistors	www.vishay.com

Note: Indicate that you are using the MAX1564 when contacting these component suppliers.

MAX1564 Evaluation Kit

Evaluates: MAX1564

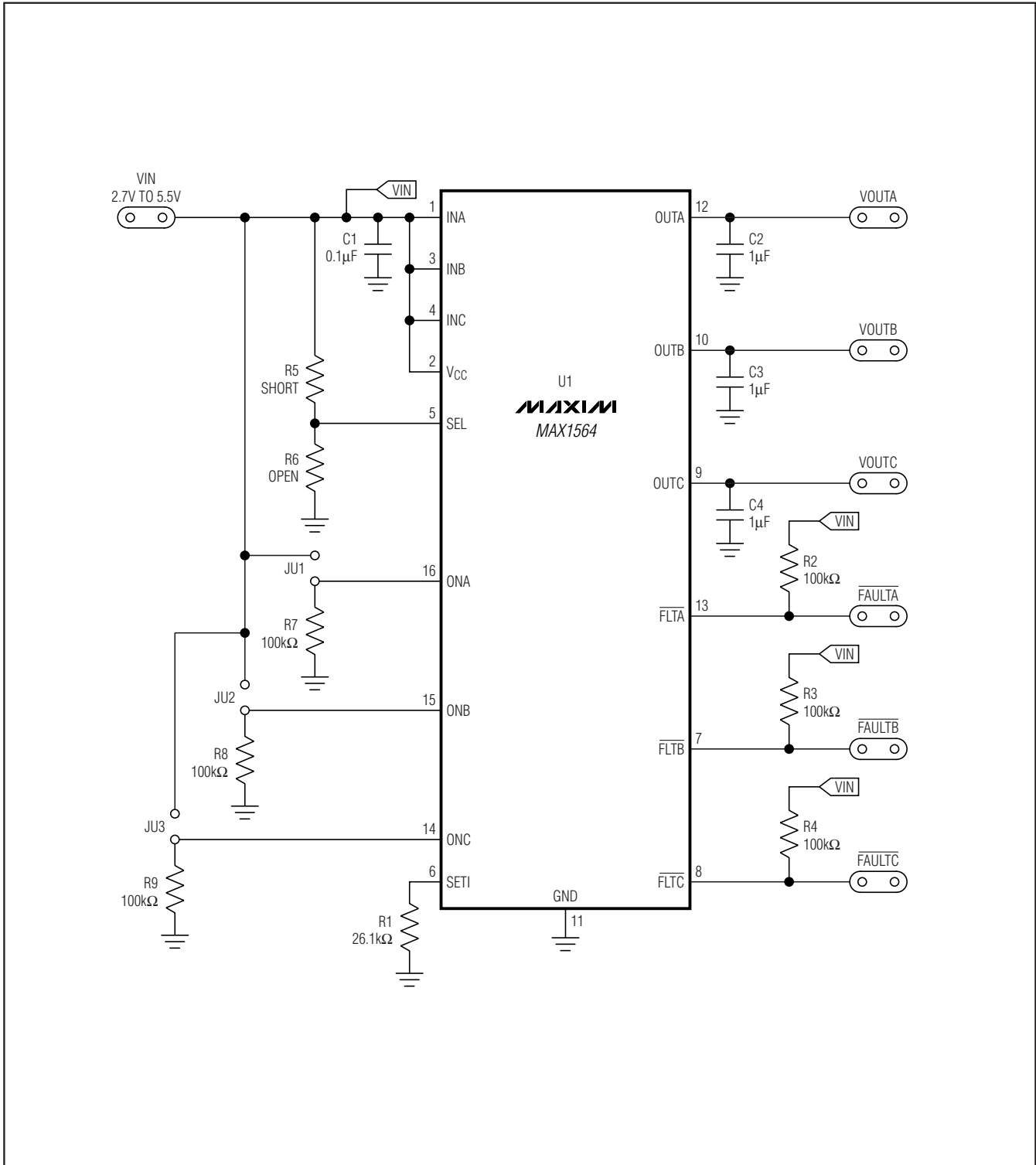

Figure 1. MAX1564 EV Kit Schematic

MAX1564 Evaluation Kit

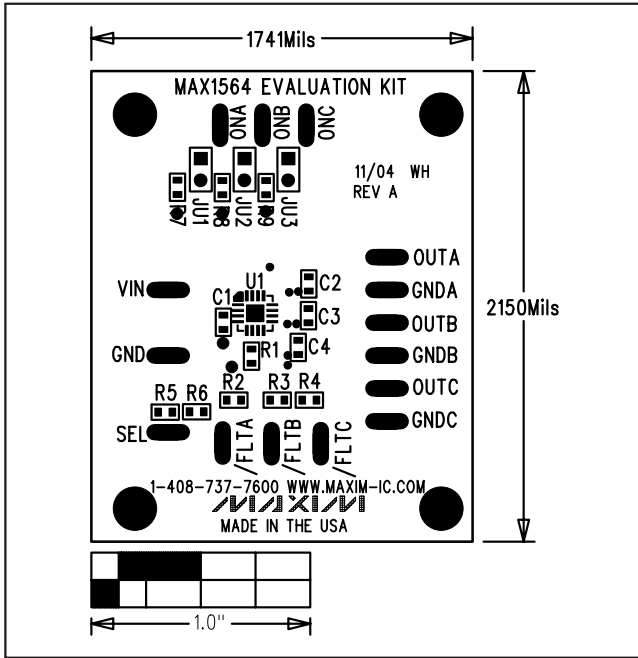

Figure 2. MAX1564 EV Kit Component Placement Guide—Top Silkscreen

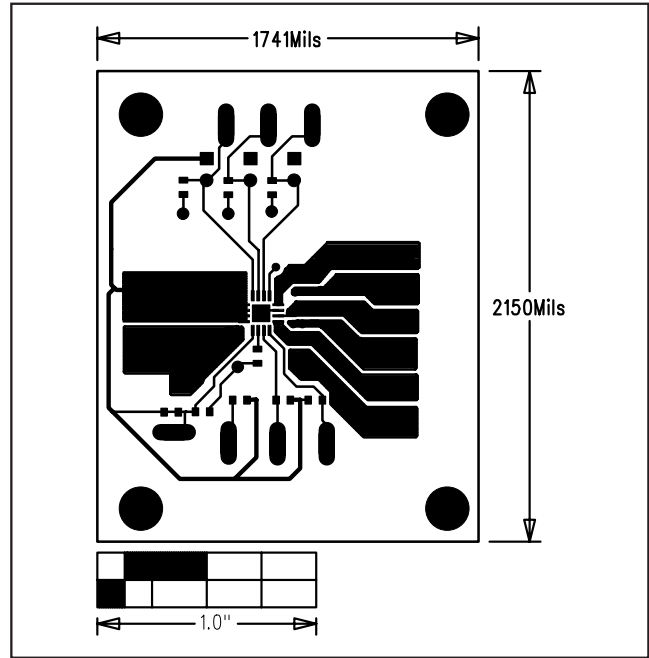

Figure 3. MAX1564 EV Kit PC Board Layout—Component Side

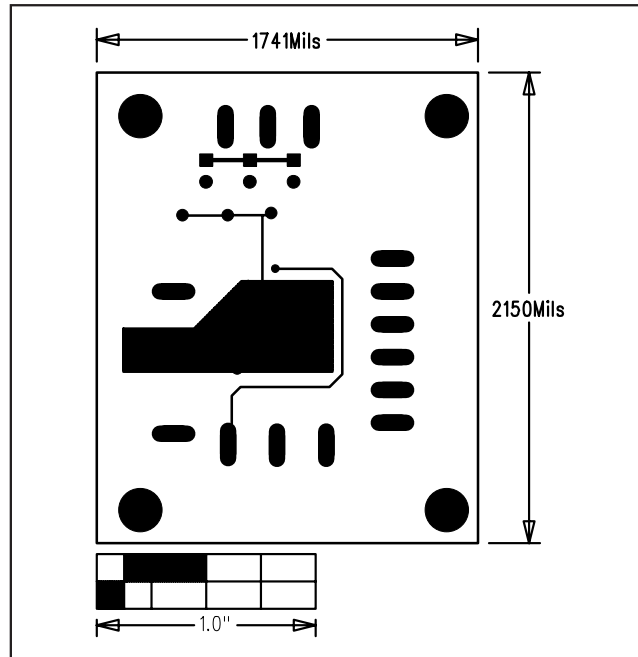

Figure 4. MAX1564 EV Kit PC Board Layout—Solder Side

Maxim cannot assume responsibility for use of any circuitry other than circuitry entirely embodied in a Maxim product. No circuit patent licenses are implied. Maxim reserves the right to change the circuitry and specifications without notice at any time.

4 Maxim Integrated Products, 120 San Gabriel Drive, Sunnyvale, CA 94086 408-737-7600

© 2006 Maxim Integrated Products

Printed USA

MAXIM is a registered trademark of Maxim Integrated Products, Inc.