

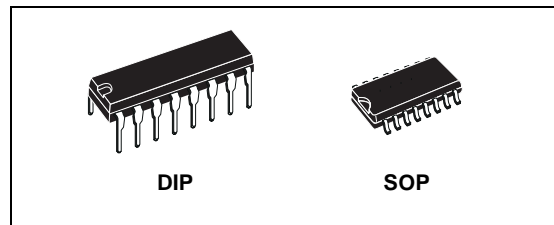

HCF4048B

MULTIFUNCTION EXPANDABLE 8-INPUT GATE

- THREE STATE OUTPUT
- MULTIPLE LOGIC FUNCTIONS AVAILABLE IN ONE PACKAGE
- STANDARDIZED SYMMETRICAL OUTPUT CHARACTERISTICS
- QUIESCENT CURRENT SPECIFIED UP TO 20V
- 5V, 10V AND 15V PARAMETRIC RATINGS
- INPUT LEAKAGE CURRENT
 $I_l = 100\text{nA (MAX) AT } V_{DD} = 18\text{V } T_A = 25^\circ\text{C}$
- 100% TESTED FOR QUIESCENT CURRENT
- MEETS ALL REQUIREMENTS OF JEDEC JESD13B "STANDARD SPECIFICATIONS FOR DESCRIPTION OF B SERIES CMOS DEVICES"



ORDER CODES

PACKAGE	TUBE	T & R
DIP	HCF4048BEY	
SOP	HCF4048BM1	HCF4048M013TR

DESCRIPTION

HCF4048B is a monolithic integrated circuit fabricated in Metal Oxide Semiconductor technology available in DIP and SOP packages. HCF4048B is an 8-input gate having four control inputs. Three binary control inputs K_a , K_b , and K_c provide the implementation of eight different logic functions. These functions are OR, NOR, AND, NAND, OR/AND, OR/NAND, AND/OR and AND/NOR. A fourth control input K_d provides the user with a 3 state output. When control input K_d is high

the output is either a logic 1 or a logic 0 depending on the inner states. When control input K_d is low, the output is an open circuit. This feature enables the user to connect this device to a common bus line. In addition to the eight input lines, an EXPAND input is provided that permits the user to increase the number of inputs to one HCF4048B. For example, two HCF4048Bs can be cascaded to provide a 16 input multifunction gate. When the EXPAND input is not used, it should be connected to V_{SS} .

PIN CONNECTION

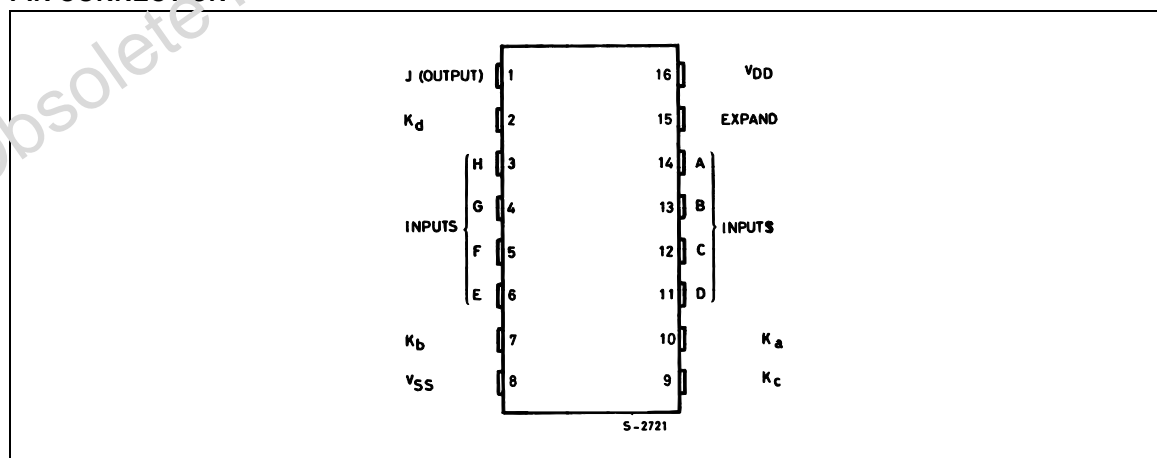

HCF4048B

INPUT EQUIVALENT CIRCUIT

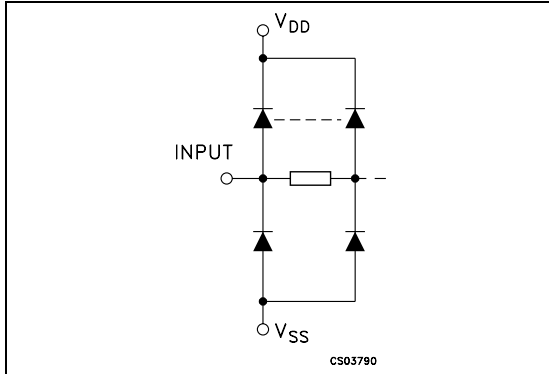

PIN DESCRIPTION

PIN No	SYMBOL	NAME AND FUNCTION
14, 13, 12, 11	A, B, C, D	Data Inputs
6, 5, 4, 3	E, F, G, H	Data Inputs
10, 7, 9	K _a , K _b , K _c	Function Control Inputs
2	K _d	3-State Control Inputs
1	J	Data Output
15	EXPAND	Expand Input
8	V _{SS}	Negative Supply Voltage
16	V _{DD}	Positive Supply Voltage

FUNCTIONAL DIAGRAM

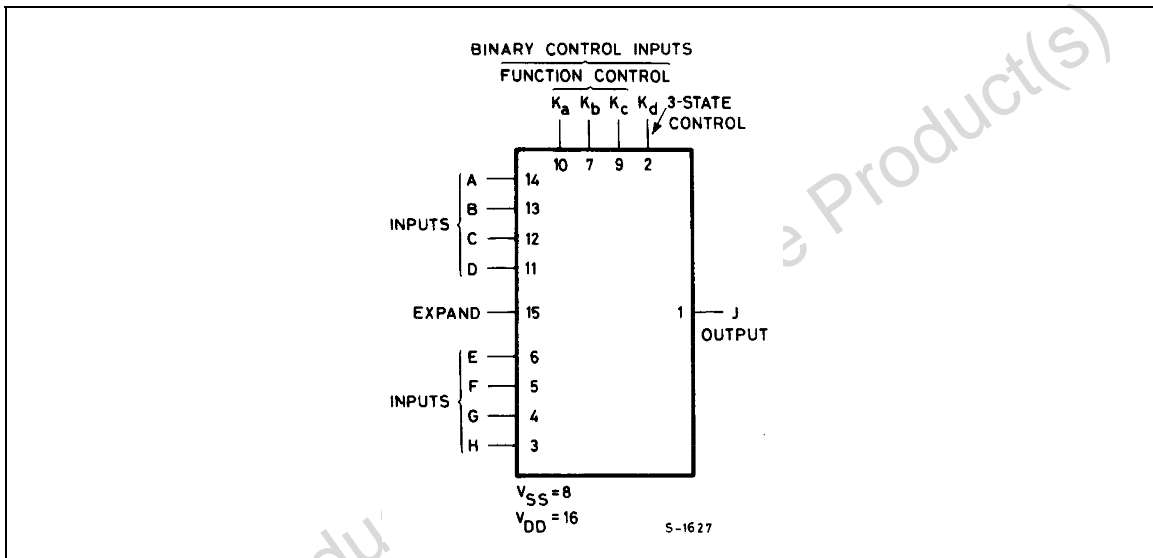

TRUTH TABLE

Output Function	Boolean Expression	K _a	K _b	K _c	Unused Input
NOR	$J = A + B + C + D + E + F + G + H$	0	0	0	V _{SS}
OR	$J = A + B + C + D + E + F + G + H$	0	0	1	V _{SS}
OR/AND	$J = (A + B + C + D) \cdot (E + F + G + H)$	0	1	0	V _{SS}
OR/NAND	$J = \overline{(A + B + C + D)} \cdot (E + F + G + H)$	0	1	1	V _{SS}
AND	$J = ABCDEFGH$	1	0	0	V _{DD}
NAND	$J = \overline{ABCDEFGH}$	1	0	1	V _{DD}
AND/NOR	$J = ABCD + EFGH$	1	1	0	V _{DD}
AND/OR	$J = ABCD + EFGH$	1	1	1	V _{DD}
K _d = 1 - NORMAL INVERTER ACTION K _d = 0 - HIGH IMPEDANCE OUTPUT					

HCF4048B

DC SPECIFICATIONS

Symbol	Parameter	Test Condition				Value						Unit	
		V _I (V)	V _O (V)	I _{OL} (μ A)	V _{DD} (V)	T _A = 25°C			-40 to 85°C		-55 to 125°C		
						Min.	Typ.	Max.	Min.	Max.	Min.		Max.
I _L	Quiescent Current	0/5			5		0.01	0.25		7.5		7.5	μ A
		0/10			10		0.01	0.5		15		15	
		0/15			15		0.01	1		30		30	
		0/20			20		0.02	5		150		150	
V _{OH}	High Level Output Voltage	0/5		<1	5	4.95			4.95		4.95		V
		0/10		<1	10	9.95			9.95		9.95		
		0/15		<1	15	14.95			14.95		14.95		
V _{OL}	Low Level Output Voltage	5/0		<1	5		0.05			0.05		0.05	V
		10/0		<1	10		0.05			0.05		0.05	
		15/0		<1	15		0.05			0.05		0.05	
V _{IH}	High Level Input Voltage		0.5/4.5	<1	5	3.5			3.5		3.5		V
			1/9	<1	10	7			7		7		
			1.5/13.5	<1	15	11			11		11		
V _{IL}	Low Level Input Voltage		4.5/0.5	<1	5			1.5		1.5		1.5	V
			9/1	<1	10			3		3		3	
			13.5/1.5	<1	15			4		4		4	
I _{OH}	Output Drive Current	0/5	2.5	<1	5	-1.36	-3.2		-1.15		-1.1		mA
		0/5	4.6	<1	5	-0.44	-1		-0.36		-0.36		
		0/10	9.5	<1	10	-1.1	-2.6		-0.9		-0.9		
		0/15	13.5	<1	15	-3.0	-6.8		-2.4		-2.4		
I _{OL}	Output Sink Current	0/5	0.4	<1	5	0.44	1		0.36		0.36		mA
		0/10	0.5	<1	10	1.1	2.6		0.9		0.9		
		0/15	1.5	<1	15	3.0	6.8		2.4		2.4		
I _I	Input Leakage Current	0/18	Any Input		18		$\pm 10^{-5}$	± 0.1		± 1		± 1	μ A
I _{OZ}	3-State Output Current	0/18	Any Input		18		$\pm 10^{-4}$	± 0.4		± 1		± 12	μ A
C _I	Input Capacitance		Any Input				5	7.5					pF

The Noise Margin for both "1" and "0" level is: 1V min. with V_{DD}=5V, 2V min. with V_{DD}=10V, 2.5V min. with V_{DD}=15V

DYNAMIC ELECTRICAL CHARACTERISTICS ($T_{amb} = 25^{\circ}\text{C}$, $C_L = 50\text{pF}$, $R_L = 200\text{K}\Omega$, $t_r = t_f = 20\text{ ns}$)

Symbol	Parameter	Test Condition		Value (*)			Unit
		V_{DD} (V)		Min.	Typ.	Max.	
t_{PHL} , t_{PLH}	Propagation Delay Time Inputs to Output and K_a to Output	5			300	600	ns
		10			150	300	
		15			120	240	
	Propagation Delay Time K_b to Output	5			225	450	ns
		10			85	170	
		15			55	110	
	Propagation Delay Time K_c to Output	5			140	280	ns
		10			50	100	
		15			40	80	
	Propagation Delay Time EXPAND Input to Output	5			190	380	ns
		10			90	180	
		15			65	130	
t_{PHZ} , t_{PLZ} t_{PZH} , t_{PZL}	3 - State Propagation Delay Time K_d to Output	5	$R_L = 1\text{K}\Omega$		80	160	ns
		10			35	70	
		15			25	50	
t_{TLH} , t_{THL}	Output Transition Time	5			100	200	ns
		10			50	100	
		15			40	80	
3-State Output Capacitance					5	10	pF

(*) Typical temperature coefficient for all V_{DD} value is 0.3 %/°C.

TEST CIRCUIT

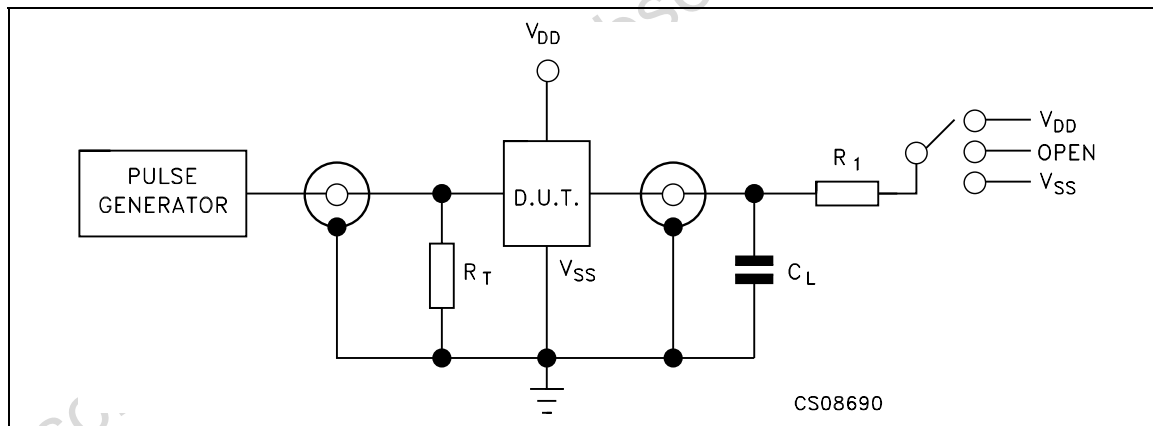

TEST	SWITCH
t_{PLH} , t_{PHL}	Open
t_{PZL} , t_{PLZ}	V_{DD}
t_{PZH} , t_{PHZ}	V_{SS}

$C_L = 50\text{pF}$ or equivalent (includes jig and probe capacitance)

$R_L = 200\text{K}\Omega$

$R_T = Z_{OUT}$ of pulse generator (typically 50Ω)

HCF4048B

WAVEFORM 1 : PROPAGATION DELAY TIMES (f=1MHz; 50% duty cycle)

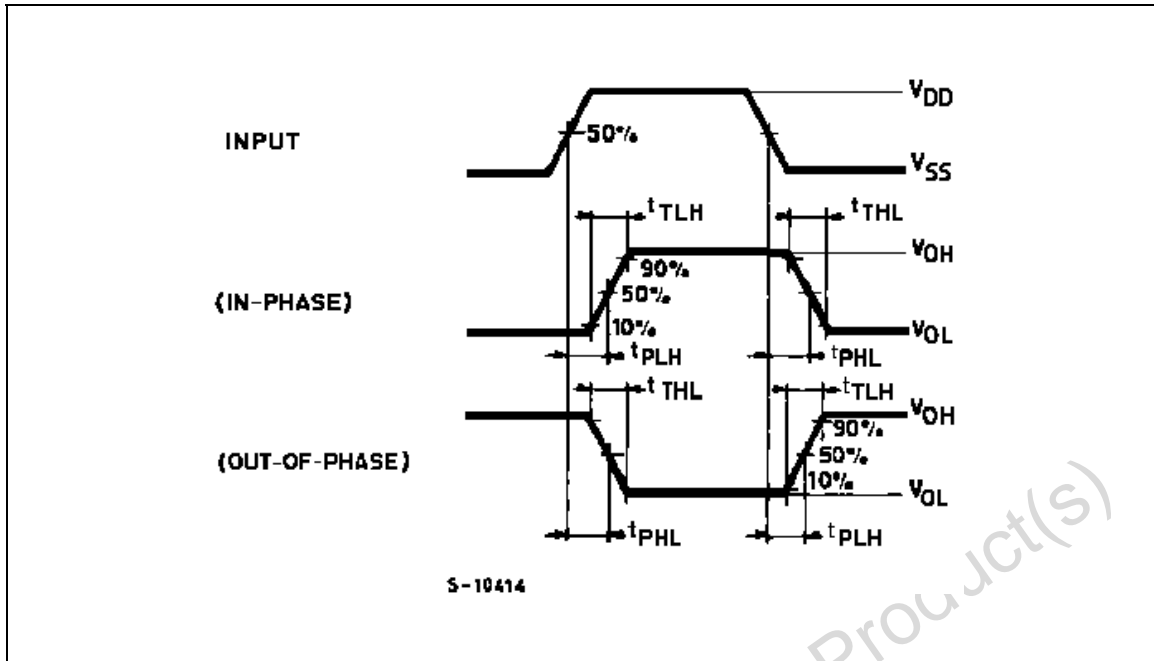

WAVEFORM 2 : OUTPUT ENABLE AND DISABLE TIME (f=1MHz; 50% duty cycle)

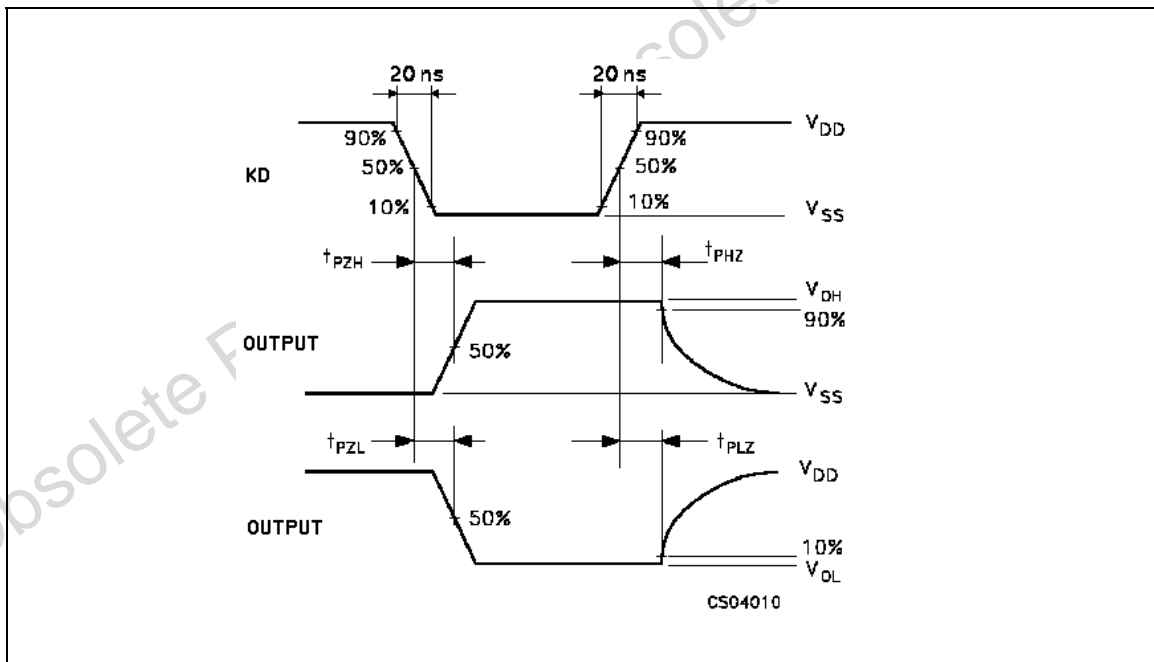

Plastic DIP-16 (0.25) MECHANICAL DATA

DIM.	mm.			inch		
	MIN.	TYP.	MAX.	MIN.	TYP.	MAX.
a1	0.51			0.020		
B	0.77		1.65	0.030		0.065
b		0.5			0.020	
b1		0.25			0.010	
D			20			0.787
E		8.5			0.335	
e		2.54			0.100	
e3		17.78			0.700	
F			7.1			0.280
I			5.1			0.201
L		3.3			0.130	
Z			1.27			0.050

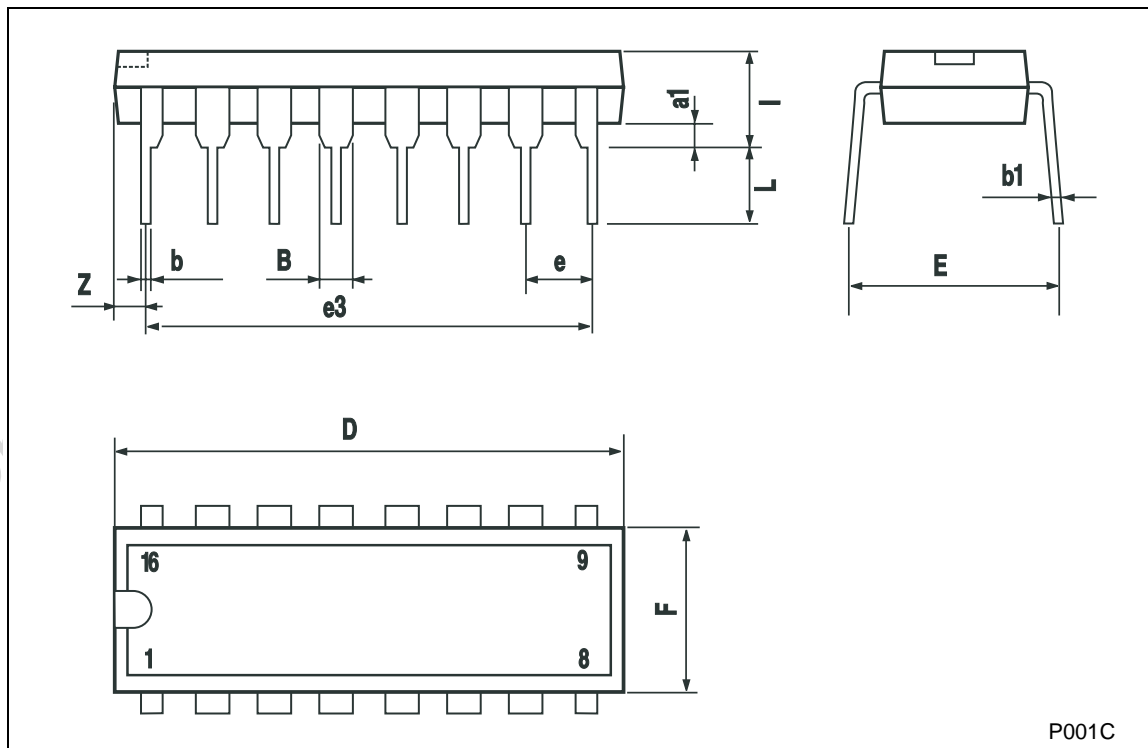

P001C

SO-16 MECHANICAL DATA

DIM.	mm.			inch		
	MIN.	TYP	MAX.	MIN.	TYP.	MAX.
A			1.75			0.068
a1	0.1		0.2	0.003		0.007
a2			1.65			0.064
b	0.35		0.46	0.013		0.018
b1	0.19		0.25	0.007		0.010
C		0.5			0.019	
c1	45° (typ.)					
D	9.8		10	0.385		0.393
E	5.8		6.2	0.228		0.244
e		1.27			0.050	
e3		8.89			0.350	
F	3.8		4.0	0.149		0.157
G	4.6		5.3	0.181		0.208
L	0.5		1.27	0.019		0.050
M			0.62			0.024
S	8° (max.)					

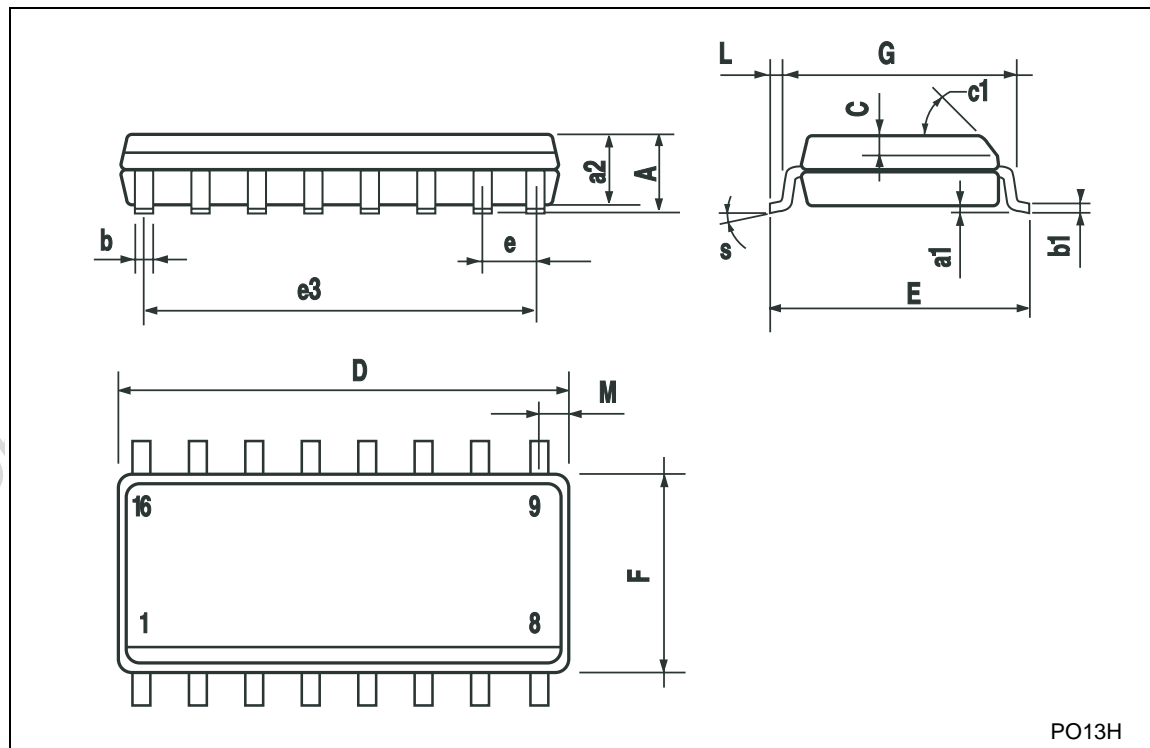

PO13H

Information furnished is believed to be accurate and reliable. However, STMicroelectronics assumes no responsibility for the consequences of use of such information nor for any infringement of patents or other rights of third parties which may result from its use. No license is granted by implication or otherwise under any patent or patent rights of STMicroelectronics. Specifications mentioned in this publication are subject to change without notice. This publication supersedes and replaces all information previously supplied. STMicroelectronics products are not authorized for use as critical components in life support devices or systems without express written approval of STMicroelectronics.

© The ST logo is a registered trademark of STMicroelectronics

© 2002 STMicroelectronics - Printed in Italy - All Rights Reserved
STMicroelectronics GROUP OF COMPANIES

Australia - Brazil - Canada - China - Finland - France - Germany - Hong Kong - India - Israel - Italy - Japan - Malaysia - Malta - Morocco
Singapore - Spain - Sweden - Switzerland - United Kingdom - United States.

© <http://www.st.com>

