

## Double channel high-side driver with analog current sense for automotive applications

Datasheet – production data

### Features

Max transient supply voltage	$V_{CC}$	41 V
Operating voltage range	$V_{CC}$	4.5 to 28V
Typ on-state resistance (per ch.)	$R_{ON}$	8 m $\Omega$
Current limitation (typ)	$I_{LIMH}$	76 A
Off-state supply current	$I_S$	2 $\mu$ A <sup>(1)</sup>

1. Typical value with all loads connected

#### ■ General:

- Inrush current active management by power limitation
- Very low standby current
- 3.0V CMOS compatible input
- Optimized electromagnetic emission
- Very low electromagnetic susceptibility
- Compliant with European directive 2002/95/EC
- Proportional load current sense
- High current sense precision for wide range current
- Very low current sense leakage

#### ■ Diagnostic functions:

- Off-state open-load detection
- Current sense disable
- Thermal shutdown indication
- Output short to  $V_{CC}$  detection
- Overload and short to ground (power limitation) indication

#### ■ Protection:

- Undervoltage shutdown
- Overvoltage clamp
- Load current limitation
- Self limiting of fast thermal transients
- Protection against loss of ground and loss of  $V_{CC}$
- Thermal shut down
- Reverse battery protection with self switch of the Power MOS



- Electrostatic discharge protection

### Applications

- All types of resistive, inductive and capacitive loads

### Description

The VND5E008AY-E is a device made using STMicroelectronics® VIPower® MO-5 technology. It is intended for driving resistive or inductive loads with one side connected to ground. Active  $V_{CC}$  pin voltage clamp protects the device against low energy spikes.

This device integrates an analog current sense which delivers a current proportional to the load current when CS\_DIS high leads the current sense pin in high impedance.

Fault conditions such as overload, overtemperature or open-load are reported via the current sense pin

Output current limitation protects the device in overload condition. In case of long overload duration, the device limits the dissipated power to safe level up to thermal shutdown intervention. Thermal shutdown with automatic restart allows the device to recover normal operation as soon as fault condition disappears.

# Contents

<b>1</b>	<b>Block diagram and pin description</b>	<b>5</b>
<b>2</b>	<b>Electrical specifications</b>	<b>7</b>
2.1	Absolute maximum ratings	7
2.2	Thermal data	8
2.3	Electrical characteristics	9
2.4	Waveforms	18
2.5	Electrical characteristics curves	22
<b>3</b>	<b>Application information</b>	<b>25</b>
3.1	Load dump protection	25
3.2	MCU I/Os protection	25
3.3	Current sense and diagnostic	26
3.3.1	Short to VCC and off-state open-load detection	27
3.4	Maximum demagnetization energy ( $V_{CC} = 13.5\text{ V}$ )	29
<b>4</b>	<b>Package and PCB thermal data</b>	<b>30</b>
4.1	PowerSSO-36 thermal data	30
<b>5</b>	<b>Package information</b>	<b>33</b>
5.1	ECOPACK <sup>®</sup> packages	33
5.2	PowerSSO-36 mechanical data	34
5.3	Packing information	36
<b>6</b>	<b>Order codes</b>	<b>37</b>
<b>7</b>	<b>Revision history</b>	<b>38</b>

## List of tables

Table 1.	Pin function . . . . .	5
Table 2.	Suggested connections for unused and not connected pins . . . . .	6
Table 3.	Absolute maximum ratings . . . . .	7
Table 4.	Thermal data . . . . .	8
Table 5.	Power section . . . . .	9
Table 6.	Switching ( $V_{CC} = 13V$ ; $T_j = 25^{\circ}C$ ) . . . . .	9
Table 7.	Current sense ( $8 V < V_{CC} < 18 V$ ) . . . . .	10
Table 8.	Open-load detection ( $8 V < V_{CC} < 18 V$ ) . . . . .	11
Table 9.	Protections . . . . .	11
Table 10.	Logic input . . . . .	12
Table 11.	Truth table . . . . .	14
Table 12.	Electrical transient requirements (part 1) . . . . .	17
Table 13.	Electrical transient requirements (part 2) . . . . .	17
Table 14.	Electrical transient requirements (part 3) . . . . .	17
Table 15.	Thermal parameter . . . . .	32
Table 16.	PowerSSO-36 mechanical data . . . . .	35
Table 17.	Device summary . . . . .	37
Table 18.	Document revision history . . . . .	38

## List of figures

Figure 1.	Block diagram . . . . .	5
Figure 2.	Configuration diagram (top view) . . . . .	6
Figure 3.	Current and voltage conventions . . . . .	7
Figure 4.	Current sense delay characteristics . . . . .	12
Figure 5.	Open-load off-state delay timing. . . . .	13
Figure 6.	$I_{OUT}/I_{SENSE}$ vs $I_{OUT}$ . . . . .	13
Figure 7.	Maximum current sense ratio drift vs load current . . . . .	14
Figure 8.	Switching characteristics . . . . .	15
Figure 9.	Delay response time between rising edge of output current and rising edge of current sense (CS enabled). . . . .	16
Figure 10.	Output voltage drop limitation . . . . .	16
Figure 11.	Normal operation . . . . .	18
Figure 12.	Overload or short to GND . . . . .	18
Figure 13.	Intermittent overload . . . . .	19
Figure 14.	Off-state open-load with external circuitry . . . . .	20
Figure 15.	Short to $V_{CC}$ . . . . .	21
Figure 16.	$T_J$ evolution in overload or short to GND . . . . .	21
Figure 17.	Off-state output current. . . . .	22
Figure 18.	High level input current. . . . .	22
Figure 19.	Input clamp voltage. . . . .	22
Figure 20.	Input high level . . . . .	22
Figure 21.	Input low level . . . . .	22
Figure 22.	Input hysteresis voltage . . . . .	22
Figure 23.	On-state resistance vs $T_{case}$ . . . . .	23
Figure 24.	On-state resistance vs $V_{CC}$ . . . . .	23
Figure 25.	Undervoltage shutdown . . . . .	23
Figure 26.	$I_{LIMH}$ vs $T_{case}$ . . . . .	23
Figure 27.	Turn-on voltage slope. . . . .	23
Figure 28.	Turn-off voltage slope. . . . .	23
Figure 29.	CS_DIS clamp voltage . . . . .	24
Figure 30.	Low level CS_DIS voltage . . . . .	24
Figure 31.	High level CS_DIS voltage . . . . .	24
Figure 32.	Application schematic. . . . .	25
Figure 33.	Current sense and diagnostic. . . . .	27
Figure 34.	Maximum turn-off current versus inductance . . . . .	29
Figure 35.	PowerSSO-36 PC board. . . . .	30
Figure 36.	$R_{thj-amb}$ vs PCB copper area in open box free air condition (one channel ON) . . . . .	31
Figure 37.	PowerSSO-36 Thermal impedance junction ambient single pulse (one channel ON) . . . . .	31
Figure 38.	Thermal fitting model of a double channel HSD in PowerSSO-36 . . . . .	32
Figure 39.	PowerSSO-36 package dimensions . . . . .	34
Figure 40.	PowerSSO-36 tube shipment (no suffix) . . . . .	36
Figure 41.	PowerSSO-36 tape and reel shipment (suffix "TR") . . . . .	36

# 1 Block diagram and pin description

Figure 1. Block diagram

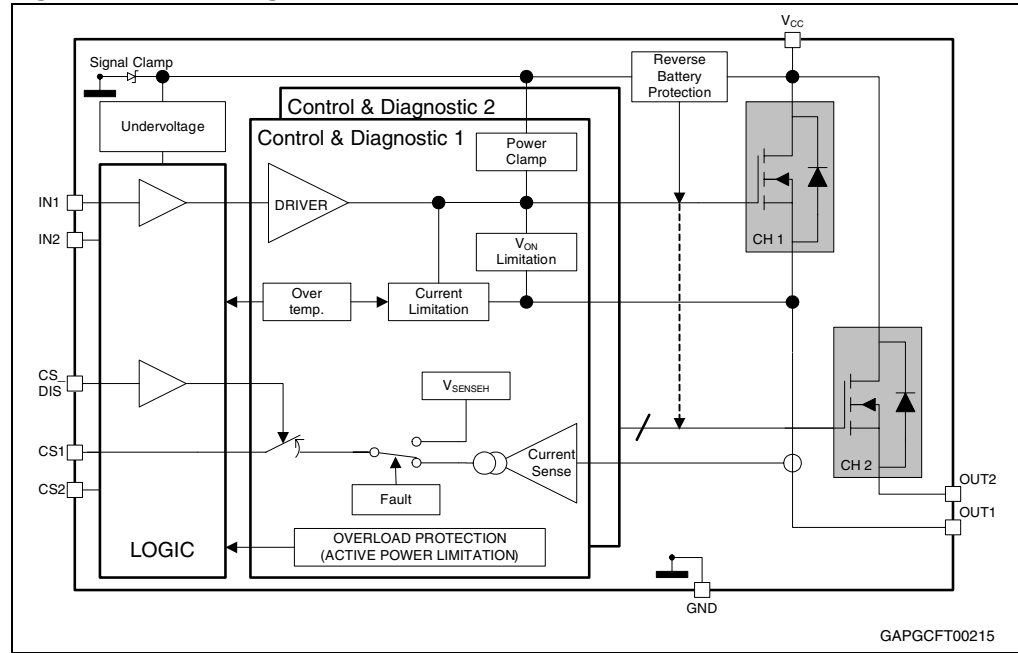

Table 1. Pin function

Name	Function
$V_{CC}$	Battery connection
OUT <sub>1,2</sub>	Power output
GND	Ground connection
IN <sub>1,2</sub>	Voltage controlled input pin with hysteresis, CMOS compatible. Controls output switch state
CS <sub>1,2</sub>	Analog current sense pin, delivers a current proportional to the load current
CS_DIS	Active high CMOS compatible pin, to disable the current sense pin

Figure 2. Configuration diagram (top view)

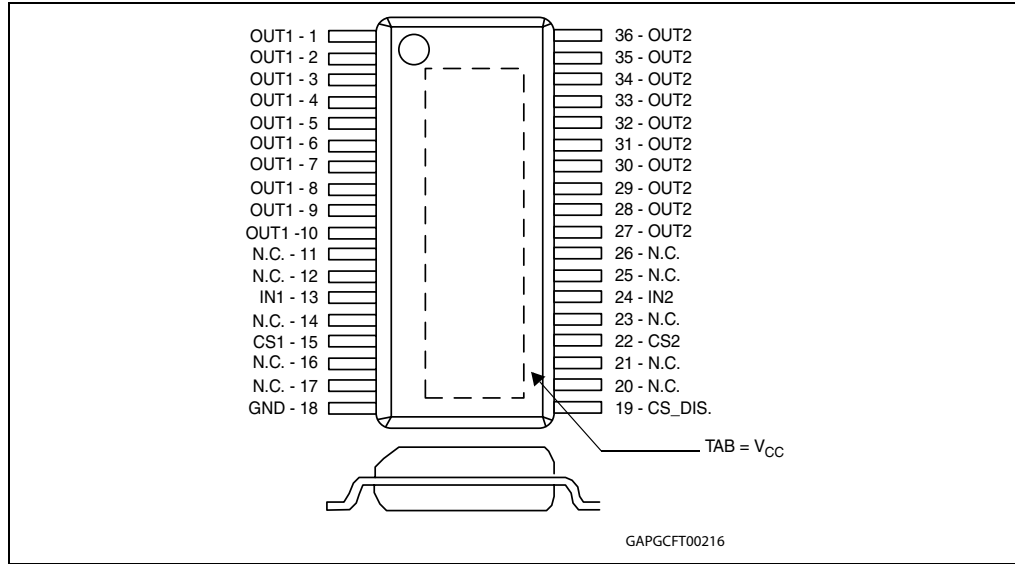
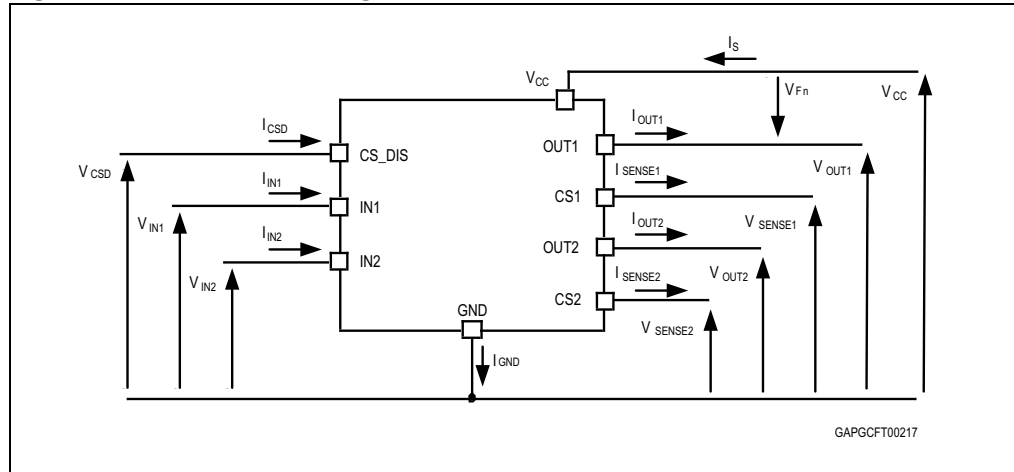

Table 2. Suggested connections for unused and not connected pins

Connection / pin	Current sense	N.C.	Output	Input	CS_DIS
Floating	Not allowed	X	X	X	X
To ground	Through 1 K $\Omega$ resistor	X	Not allowed	Through 10 K $\Omega$ resistor	Through 10 K $\Omega$ resistor

## 2 Electrical specifications

Figure 3. Current and voltage conventions



### 2.1 Absolute maximum ratings

Table 3. Absolute maximum ratings

Symbol	Parameter	Value	Unit
$V_{CC}$	DC supply voltage	28	V
$V_{CCPK}$	Transient supply voltage ( $T < 400$ ms, $R_{LOAD} > 1 \Omega$ )	41	V
$-V_{CC}$	Reverse DC supply voltage	16	V
$V_{CC\_LSC}$	Maximum supply voltage for full protection to short-circuit (acc. AEC-Q100-012)	18	V
$-I_{GND}$	DC reverse ground pin current	200	mA
$I_{OUT}$	DC output current	Internally limited	A
$-I_{OUT}$	Reverse DC output current	50	A
$I_{IN}$	DC input current	-1 to 10	mA
$I_{CSD}$	DC current sense disable input current	-1 to 10	mA
$V_{CSENSE}$	Current sense maximum voltage	$V_{CC} - 41$ $+V_{CC}$	V V
$E_{MAX}$	Maximum switching energy (single pulse) ( $L = 0.85$ mH; $R_L = 0 \Omega$ ; $V_{bat} = 13.5$ V; $T_{jstart} = 150$ °C; $I_{OUT} = I_{limL}(Typ.)$ )	260	mJ
$V_{ESD}$	Electrostatic Discharge (Human Body Model: $R = 1.5$ K $\Omega$ ; $C = 100$ pF) – $V_{CC}$ , OUTPUT – INPUT, CS_DIS – CURRENT SENSE	5000 4000 2000	V

**Table 3. Absolute maximum ratings (continued)**

Symbol	Parameter	Value	Unit
$V_{ESD}$	Charge device model (CDM-AEC-Q100-011)	750	V
$T_j$	Junction operating temperature	-40 to 150	°C
$T_{stg}$	Storage temperature	-55 to 150	°C

## 2.2 Thermal data

**Table 4. Thermal data**

Symbol	Parameter	Max. value	Unit
$R_{thj-case}$	Thermal resistance junction-case (MAX) (with one channel ON)	0.85	°C/W
$R_{thj-amb}$	Thermal resistance junction-ambient (MAX)	See <a href="#">Figure 36</a> in the Thermal section	°C/W



## 2.3 Electrical characteristics

8 V < V<sub>CC</sub> < 28 V; -40 °C < T<sub>j</sub> < 150 °C, unless otherwise specified

**Table 5. Power section**

Symbol	Parameter	Test conditions	Min.	Typ.	Max.	Unit
V <sub>CC</sub>	Operating supply voltage		4.5	13	28	V
V <sub>USD</sub>	Undervoltage shutdown			3.5	4.5	V
V <sub>USDhyst</sub>	Undervoltage shutdown hysteresis			0.5		V
R <sub>ON</sub>	ON-state resistance	I <sub>OUT</sub> = 6 A; T <sub>j</sub> = 25 °C		8		mΩ
		I <sub>OUT</sub> = 6 A; T <sub>j</sub> = 150 °C			15	mΩ
		I <sub>OUT</sub> = 6 A; V <sub>CC</sub> = 5 V; T <sub>j</sub> = 25 °C			11	mΩ
R <sub>ON REV</sub>	Reverse battery ON-state resistance	V <sub>CC</sub> = -13 V; I <sub>OUT</sub> = -6 A; T <sub>j</sub> = 25 °C		8		mΩ
V <sub>clamp</sub>	Clamp Voltage	I <sub>S</sub> = 20 mA	41	46	52	V
I <sub>S</sub>	Supply current	Off-state; V <sub>CC</sub> = 13 V; T <sub>j</sub> = 25 °C; V <sub>IN</sub> = V <sub>OUT</sub> = V <sub>SENSE</sub> = V <sub>CSD</sub> = 0 V		2 <sup>(1)</sup>	5 <sup>(1)</sup>	μA
		On-state; V <sub>CC</sub> = 13 V; V <sub>IN</sub> = 5 V; I <sub>OUT</sub> = 0 A		3.5	6.5	mA
I <sub>L(off)</sub>	Off-state output current <sup>(2)</sup>	V <sub>IN</sub> = V <sub>OUT</sub> = 0 V; V <sub>CC</sub> = 13 V; T <sub>j</sub> = 25 °C	0	0.01	3	μA
		V <sub>IN</sub> = V <sub>OUT</sub> = 0 V; V <sub>CC</sub> = 13 V; T <sub>j</sub> = 125 °C			5	μA

1. PowerMOS leakage included.
2. For each channel.

**Table 6. Switching (V<sub>CC</sub> = 13V; T<sub>j</sub> = 25°C)**

Symbol	Parameter	Test conditions	Min.	Typ.	Max.	Unit
t <sub>d(on)</sub>	Turn-on delay time	R <sub>L</sub> = 2.2 Ω (see <a href="#">Figure 8</a> )	—	30	—	μs
t <sub>d(off)</sub>	Turn-off delay time	R <sub>L</sub> = 2.2 Ω (see <a href="#">Figure 8</a> )	—	15	—	μs
(dV <sub>OUT</sub> /dt) <sub>on</sub>	Turn-on voltage slope	R <sub>L</sub> = 2.2 Ω	—	See <a href="#">Figure 23</a>	—	V/μs
(dV <sub>OUT</sub> /dt) <sub>off</sub>	Turn-off voltage slope	R <sub>L</sub> = 2.2 Ω	—	See <a href="#">Figure 24</a>	—	V/μs
W <sub>ON</sub>	Switching energy losses during t <sub>won</sub>	R <sub>L</sub> = 2.2 Ω (see <a href="#">Figure 8</a> )	—	1.2	—	mJ
W <sub>OFF</sub>	Switching energy losses during t <sub>woff</sub>	R <sub>L</sub> = 2.2 Ω (see <a href="#">Figure 8</a> )	—	0.43	—	mJ

Table 7. Current sense (8 V < V<sub>CC</sub> < 18 V)

Symbol	Parameter	Test conditions	Min.	Typ.	Max.	Unit
K <sub>0</sub>	I <sub>OUT</sub> /I <sub>SENSE</sub>	I <sub>OUT</sub> = 0.25 A; V <sub>SENSE</sub> = 0.5 V T <sub>j</sub> = -40 °C...150 °C	3658	6000	8926	
K <sub>1</sub>	I <sub>OUT</sub> /I <sub>SENSE</sub>	I <sub>OUT</sub> = 6 A; V <sub>SENSE</sub> = 0.5 V T <sub>j</sub> = -40 °C...150 °C T <sub>j</sub> = 25 °C...150 °C	3910 4336	6000 6000	8928 8044	
dK <sub>1</sub> /K <sub>1</sub> <sup>(1)</sup>	Current sense ratio drift	I <sub>OUT</sub> = 6 A; V <sub>SENSE</sub> = 0.5 V V <sub>CSD</sub> = 0 V; T <sub>j</sub> = -40 °C to 150 °C	-12		12	%
K <sub>2</sub>	I <sub>OUT</sub> /I <sub>SENSE</sub>	I <sub>OUT</sub> = 10 A; V <sub>SENSE</sub> = 4 V T <sub>j</sub> = -40 °C...150 °C T <sub>j</sub> = 25 °C...150 °C	4948 5298	6000 6000	7372 6762	
dK <sub>2</sub> /K <sub>2</sub> <sup>(1)</sup>	Current sense ratio drift	I <sub>OUT</sub> = 10 A; V <sub>SENSE</sub> = 4 V; V <sub>CSD</sub> = 0 V; T <sub>j</sub> = -40 °C to 150 °C	-7		7	%
K <sub>3</sub>	I <sub>OUT</sub> /I <sub>SENSE</sub>	I <sub>OUT</sub> = 25 A; V <sub>SENSE</sub> = 4 V T <sub>j</sub> = -40 °C...150 °C T <sub>j</sub> = 25 °C...150 °C	5455 5535	6000 6000	6762 6282	
dK <sub>3</sub> /K <sub>3</sub> <sup>(1)</sup>	Current sense ratio drift	I <sub>OUT</sub> = 25 A; V <sub>SENSE</sub> = 4 V; V <sub>CSD</sub> = 0V; T <sub>j</sub> = -40 °C to 150 °C	-5		5	%
I <sub>SENSE0</sub>	Analog sense leakage current	I <sub>OUT</sub> = 0 A; V <sub>SENSE</sub> = 0 V; V <sub>CSD</sub> = 5 V; V <sub>IN</sub> = 0 V; T <sub>j</sub> = -40 °C...150 °C	0		1	μA
		V <sub>CSD</sub> = 0 V; V <sub>IN</sub> = 5 V; T <sub>j</sub> = -40 °C...150 °C	0		2	μA
		I <sub>OUT</sub> = 6 A; V <sub>SENSE</sub> = 0 V; V <sub>CSD</sub> = V <sub>IN</sub> = 5 V;	0		1	μA
V <sub>SENSE</sub>	Max analog sense output voltage	I <sub>OUT</sub> = 15 A; V <sub>CSD</sub> = 0 V	5			V
V <sub>SENSEH</sub>	Analog sense output voltage in overtemperature condition <sup>(2)</sup>	V <sub>CC</sub> = 13 V; R <sub>SENSE</sub> = 10 KΩ		8		V
I <sub>SENSEH</sub>	Analog sense output current in overtemperature condition <sup>(2)</sup>	V <sub>CC</sub> = 13 V; V <sub>SENSE</sub> = 5 V		9		mA
t <sub>DSENSE1H</sub>	Delay Response time from falling edge of CS_DIS pin	V <sub>SENSE</sub> < 4 V, 1.5 A < I <sub>OUT</sub> < 25 A I <sub>SENSE</sub> = 90 % of I <sub>SENSE</sub> max (see <a href="#">Figure 4</a> )		50	100	μs

**Table 7. Current sense (8 V < V<sub>CC</sub> < 18 V) (continued)**

Symbol	Parameter	Test conditions	Min.	Typ.	Max.	Unit
t <sub>DSENSE1L</sub>	Delay Response time from rising edge of CS_DIS pin	V <sub>SENSE</sub> < 4 V, 1.5 A < I <sub>OUT</sub> < 25 A I <sub>SENSE</sub> = 10 % of I <sub>SENSE max</sub> (see <a href="#">Figure 4</a> )		5	20	μs
t <sub>DSENSE2H</sub>	Delay Response time from rising edge of INPUT pin	V <sub>SENSE</sub> < 4 V, 1.5 A < I <sub>OUT</sub> < 25 A I <sub>SENSE</sub> = 90 % of I <sub>SENSE max</sub> (see <a href="#">Figure 4</a> )		70	300	μs
Δt <sub>DSENSE2H</sub>	Delay response time between rising edge of output current and rising edge of current sense	V <sub>SENSE</sub> < 4 V, I <sub>SENSE</sub> = 90 % of I <sub>SENSEMAX</sub> , I <sub>OUT</sub> = 90 % of I <sub>OUTMAX</sub> I <sub>OUTMAX</sub> = 5 A (see <a href="#">Figure 11</a> )			300	μs
t <sub>DSENSE2L</sub>	Delay Response time from falling edge of INPUT pin	V <sub>SENSE</sub> < 4 V, 1.5 A < I <sub>OUT</sub> < 25 A I <sub>SENSE</sub> = 10 % of I <sub>SENSE max</sub> (see <a href="#">Figure 4</a> )		100	250	μs

1. Parameter guaranteed by design; it is not tested.
2. Fault condition includes: power limitation, overtemperature and open load OFF-state detection.

**Table 8. Open-load detection (8 V < V<sub>CC</sub> < 18 V)**

Symbol	Parameter	Test conditions	Min	Typ	Max	Unit
V <sub>OL</sub>	Open-load off-state voltage detection threshold	V <sub>IN</sub> = 0 V	2	—	4	V
t <sub>DSTKON</sub>	Output short circuit to V <sub>CC</sub> detection delay at turn-off	See <a href="#">Figure 5</a>	180	—	1200	μs
I <sub>L(off2)r</sub>	Off-state output current at V <sub>OUT</sub> = 4 V	V <sub>IN</sub> = 0V; V <sub>SENSE</sub> = 0 V; V <sub>OUT</sub> rising from 0 V to 4 V	-120	—	90	μA
I <sub>L(off2)f</sub>	Off-state output current at V <sub>OUT</sub> = 2 V	V <sub>IN</sub> = 0V; V <sub>SENSE</sub> = V <sub>SENSEH</sub> ; V <sub>OUT</sub> falling from V <sub>CC</sub> to 2 V	-50	—	90	μA

**Table 9. Protections <sup>(1)</sup>**

Symbol	Parameter	Test conditions	Min.	Typ.	Max.	Unit
I <sub>limH</sub>	DC short circuit current	V <sub>CC</sub> = 13 V	53	76	106	A
		5 V < V <sub>CC</sub> < 18 V			106	A
I <sub>limL</sub>	Short circuit current during thermal cycling	V <sub>CC</sub> = 13 V; T <sub>R</sub> < T <sub>j</sub> < T <sub>TSD</sub>		21		A
T <sub>TSD</sub>	Shutdown temperature		150	175	200	°C
T <sub>R</sub>	Reset temperature		T <sub>RS</sub> + 1	T <sub>RS</sub> + 5		°C
T <sub>RS</sub>	Thermal reset of STATUS		135			°C

**Table 9. Protections <sup>(1)</sup> (continued)**

Symbol	Parameter	Test conditions	Min.	Typ.	Max.	Unit
T <sub>HYST</sub>	Thermal hysteresis (T <sub>TSD</sub> - T <sub>R</sub> )			7		°C
V <sub>DEMAG</sub>	Turn-off output voltage clamp	I <sub>OUT</sub> = 2 A; V <sub>IN</sub> = 0; L = 6 mH	V <sub>CC</sub> -29	V <sub>CC</sub> -32	V <sub>CC</sub> -36	V
V <sub>ON</sub>	Output voltage drop limitation	I <sub>OUT</sub> = 0.4 A; T <sub>j</sub> = -40 °C...150 °C (see <a href="#">Figure 10</a> )		25		mV

1. To ensure long term reliability under heavy overload or short circuit conditions, protection and related diagnostic signals must be used together with a proper software strategy. If the device is subjected to abnormal conditions, this software must limit the duration and number of activation cycles.

**Table 10. Logic input**

Symbol	Parameter	Test conditions	Min.	Typ.	Max.	Unit
V <sub>IL</sub>	Input low level voltage				0.9	V
I <sub>IL</sub>	Low level input current	V <sub>IN</sub> = 0.9 V	1			µA
V <sub>IH</sub>	Input high level voltage		2.1			V
I <sub>IH</sub>	High level input current	V <sub>IN</sub> = 2.1 V			10	µA
V <sub>I(hyst)</sub>	Input hysteresis voltage		0.25			V
V <sub>ICL</sub>	Input clamp voltage	I <sub>IN</sub> = 1 mA	5.5		7	V
		I <sub>IN</sub> = -1 mA		-0.7		V
V <sub>CSDL</sub>	CS_DIS low level voltage				0.9	V
I <sub>CSDL</sub>	Low level CS_DIS current	V <sub>CSD</sub> = 0.9 V	1			µA
V <sub>CSDH</sub>	CS_DIS high level voltage		2.1			V
I <sub>CSDH</sub>	High level CS_DIS current	V <sub>CSD</sub> = 2.1 V			10	µA
V <sub>CSD(hyst)</sub>	CS_DIS hysteresis voltage		0.25			V
V <sub>CSCL</sub>	CS_DIS clamp voltage	I <sub>CSD</sub> = 1 mA	5.5		7	V
		I <sub>CSD</sub> = -1 mA		-0.7		V

**Figure 4. Current sense delay characteristics**

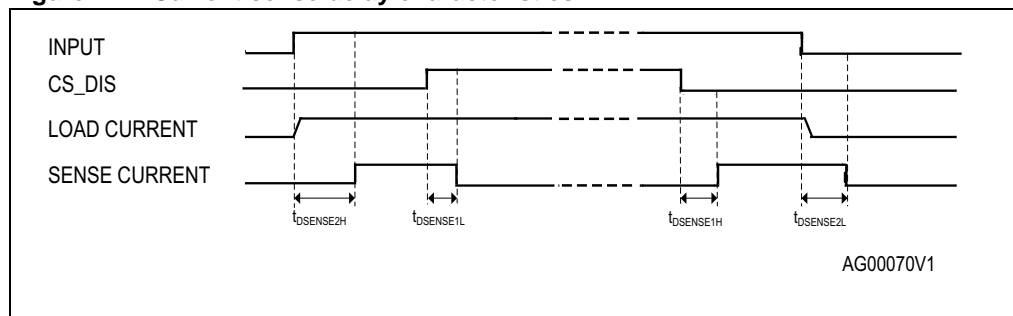

**Figure 5. Open-load off-state delay timing**

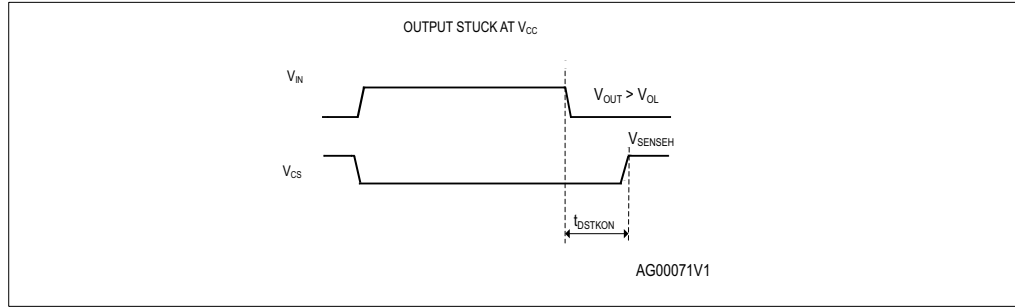

**Figure 6.  $I_{OUT}/I_{SENSE}$  vs  $I_{OUT}$**

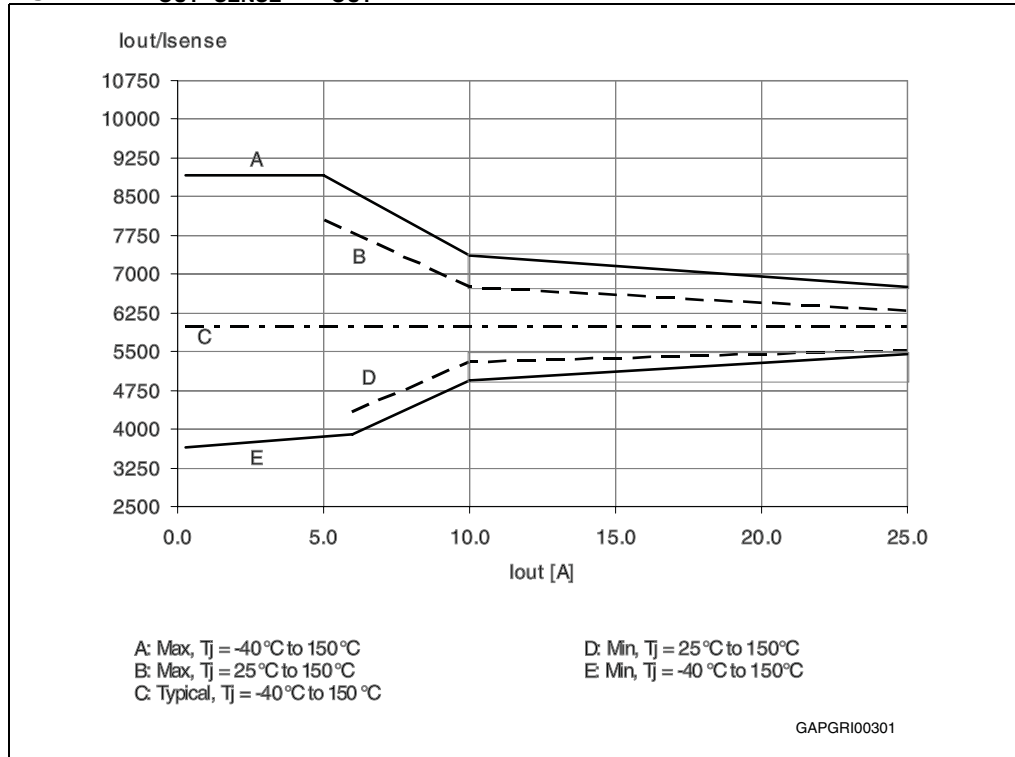

Figure 7. Maximum current sense ratio drift vs load current

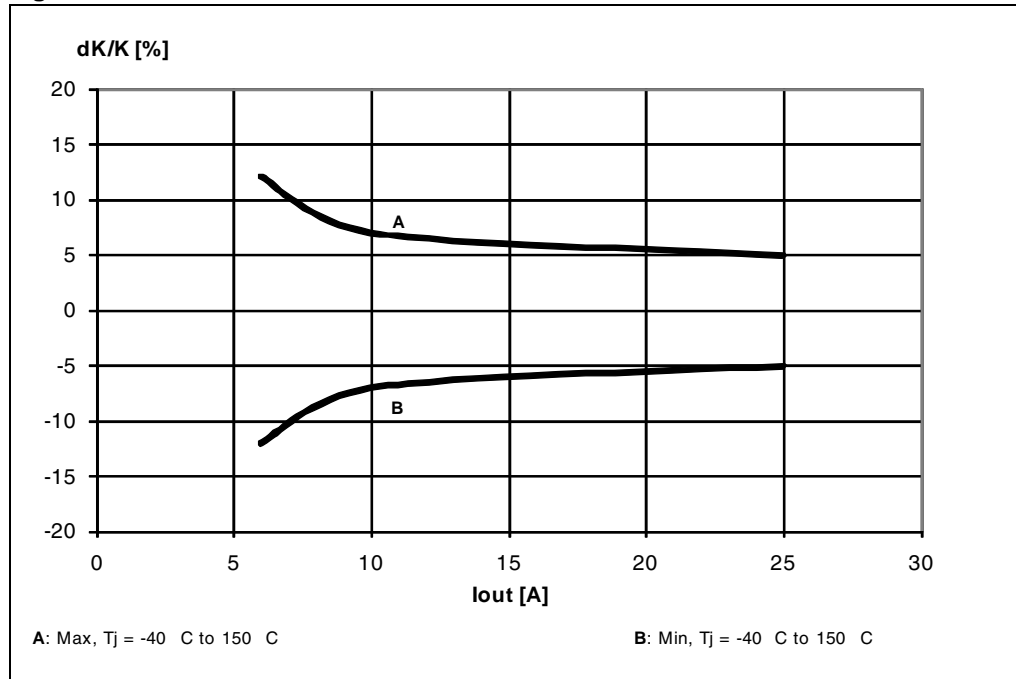

Table 11. Truth table

Conditions	Input	Output	Sense (V <sub>CSD</sub> = 0 V) <sup>(1)</sup>
Normal operation	L	L	0
	H	H	Nominal
Overtemperature	L	L	0
	H	L	V <sub>SENSEH</sub>
Undervoltage	L	L	0
	H	L	0
Overload	H	X (no power limitation)	Nominal
	H	Cycling (power limitation)	V <sub>SENSEH</sub>
Short circuit to GND (Power limitation)	L	L	0
	H	L	V <sub>SENSEH</sub>
Open-load off-state (with external pull up)	L	H	V <sub>SENSEH</sub>

**Table 11. Truth table**

Conditions	Input	Output	Sense ( $V_{CSD} = 0\text{ V}$ ) <sup>(1)</sup>
Short circuit to $V_{CC}$ (external pull up disconnected)	L H	H H	$V_{SENSEH}$ < Nominal
Negative output voltage clamp	L	L	0

1. If the  $V_{CSD}$  is high, the SENSE output is at a high impedance, its potential depends on leakage currents and external circuit.

**Figure 8. Switching characteristics**

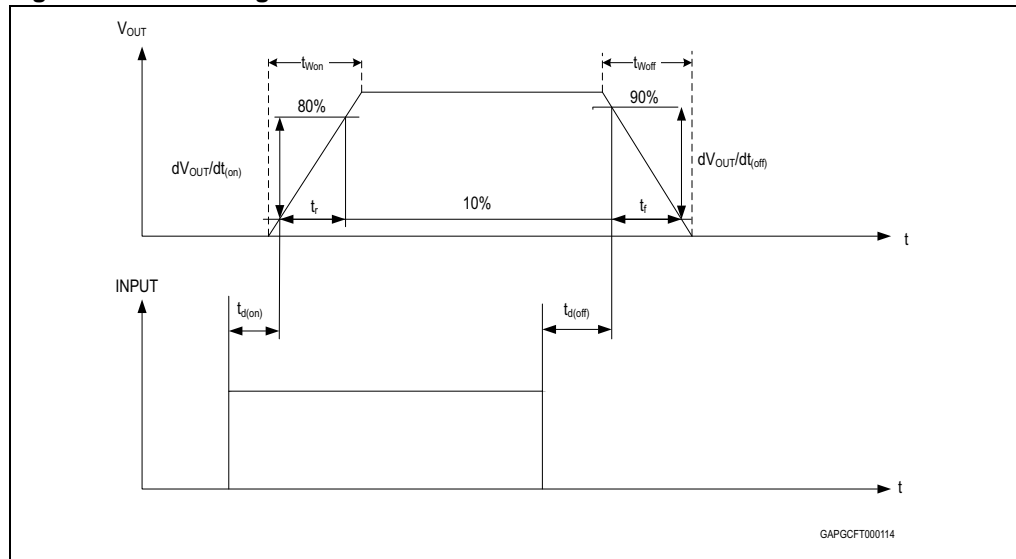

**Figure 9. Delay response time between rising edge of output current and rising edge of current sense (CS enabled)**

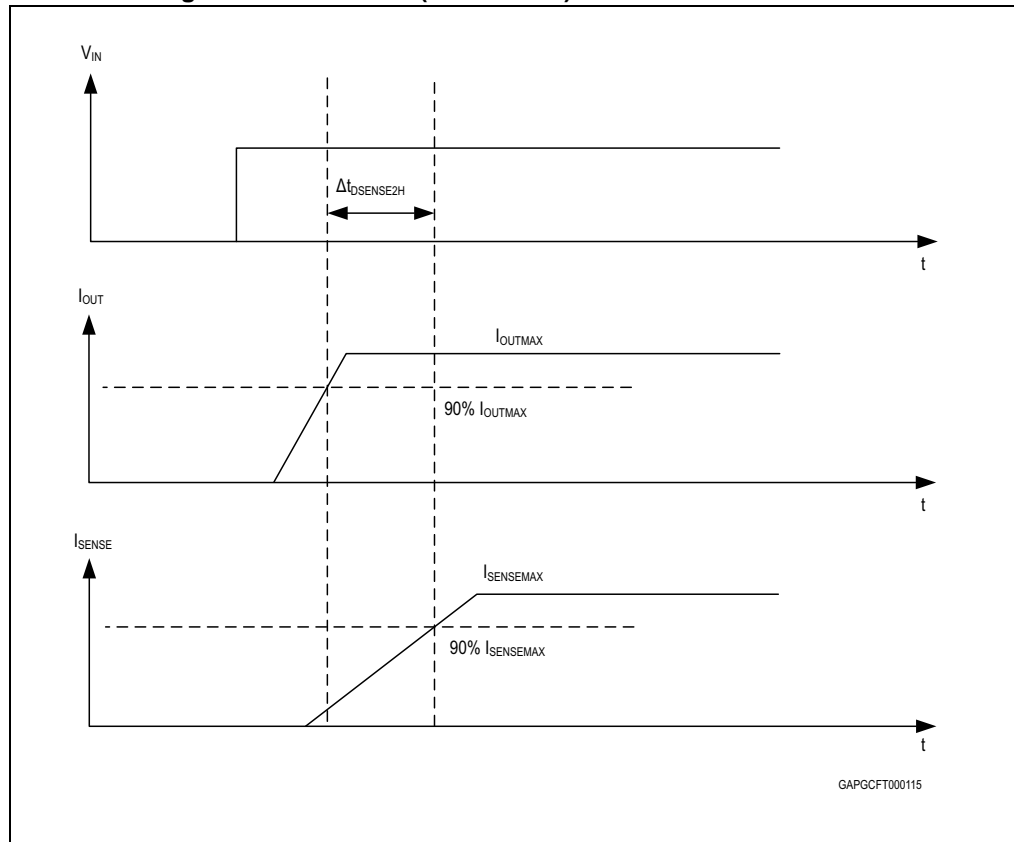

**Figure 10. Output voltage drop limitation**

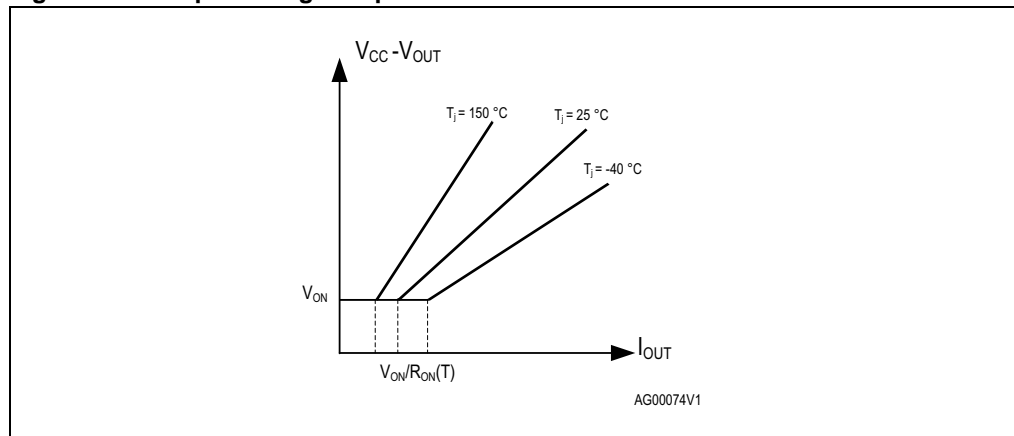



**Table 12. Electrical transient requirements (part 1)**

ISO 7637-2: 2004(E) Test pulse	Test levels <sup>(1)</sup>		Number of pulses or test times	Burst cycle/pulse repetition time		Delays and impedance
	III	IV				
1	-75 V	-100 V	5000 pulses	0.5 s	5 s	2 ms, 10 Ω
2a	+37 V	+50 V	5000 pulses	0.2 s	5 s	50 μs, 2 Ω
3a	-100 V	-150 V	1h	90 ms	100 ms	0.1 μs, 50 Ω
3b	+75 V	+100 V	1h	90 ms	100 ms	0.1 μs, 50 Ω
4	-6 V	-7 V	1 pulse			100 ms, 0.01 Ω
5b <sup>(2)</sup>	+65 V	+87 V	1 pulse			400 ms, 2 Ω

1. The above test levels must be considered referred to  $V_{CC} = 13.5$  V except for pulse 5b.
2. Valid in case of external load dump clamp: 40V maximum referred to ground.

**Table 13. Electrical transient requirements (part 2)**

ISO 7637-2: 2004(E) Test pulse	Test level results <sup>(1)</sup>	
	III	IV
1	C	C
2a	C	C
3a	C	C
3b	C	C
4	C	C
5b <sup>(2)(3)</sup>	C	C

1. The above test levels must be considered referred to  $V_{CC} = 13.5$  V except for pulse 5b.
2. Valid in case of external load dump clamp: 40 V maximum referred to ground.
3. Suppressed load dump (pulse 5b) is withstood with a minimum load connected as specified in [Table 3: Absolute maximum ratings](#).

**Table 14. Electrical transient requirements (part 3)**

Class	Contents
C	All functions of the device are performed as designed after exposure to disturbance.
E	One or more functions of the device are not performed as designed after exposure to disturbance and cannot be returned to proper operation without replacing the device.

## 2.4 Waveforms

Figure 11. Normal operation

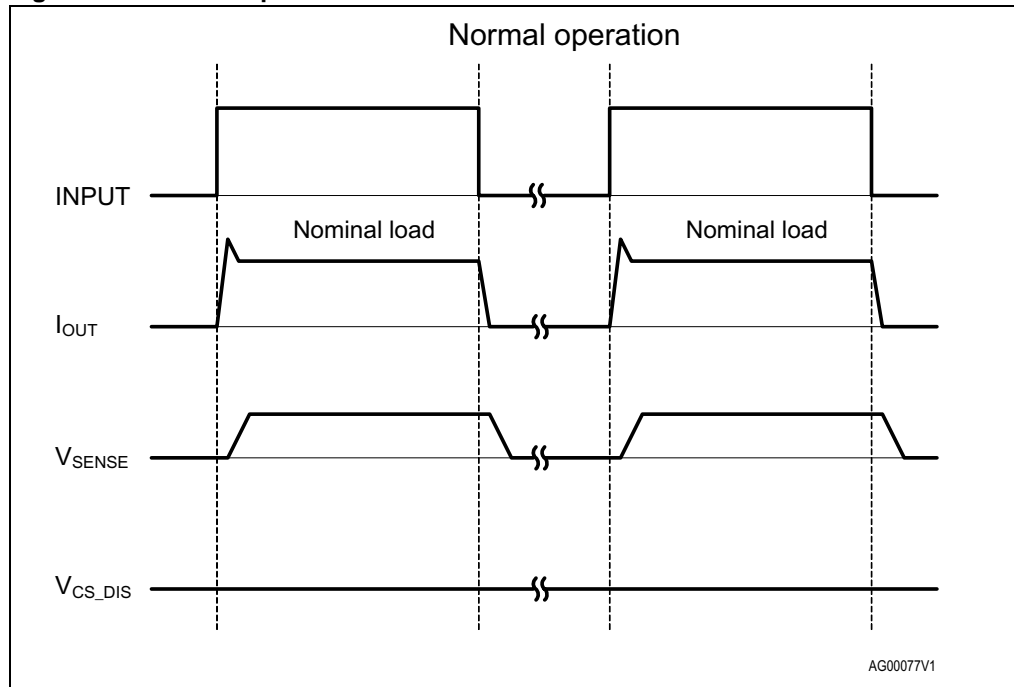

Figure 12. Overload or short to GND

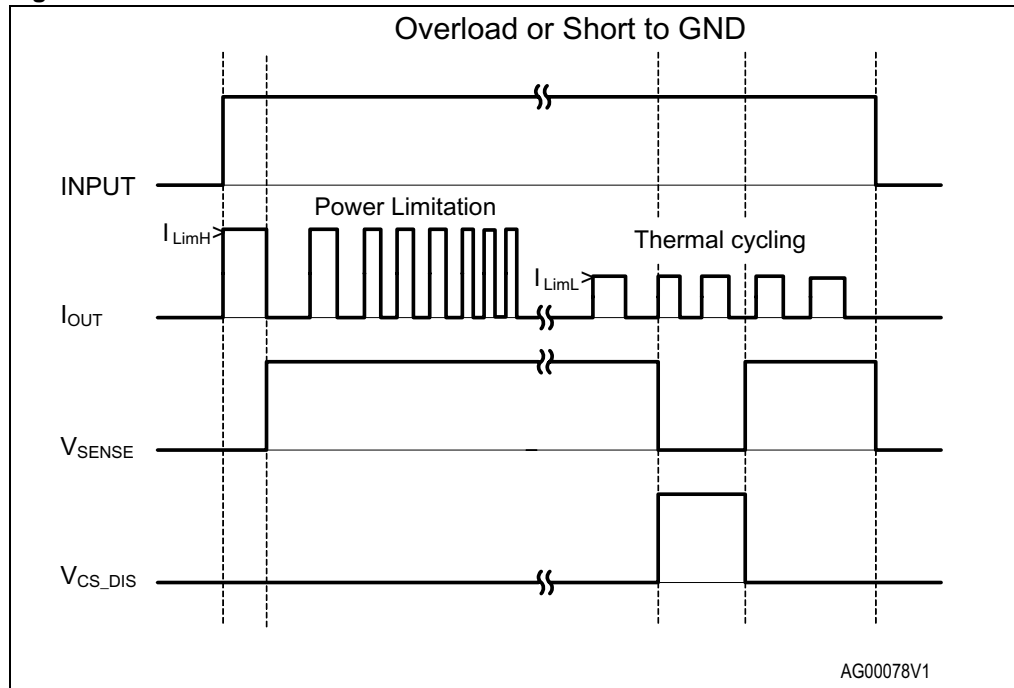

Figure 13. Intermittent overload

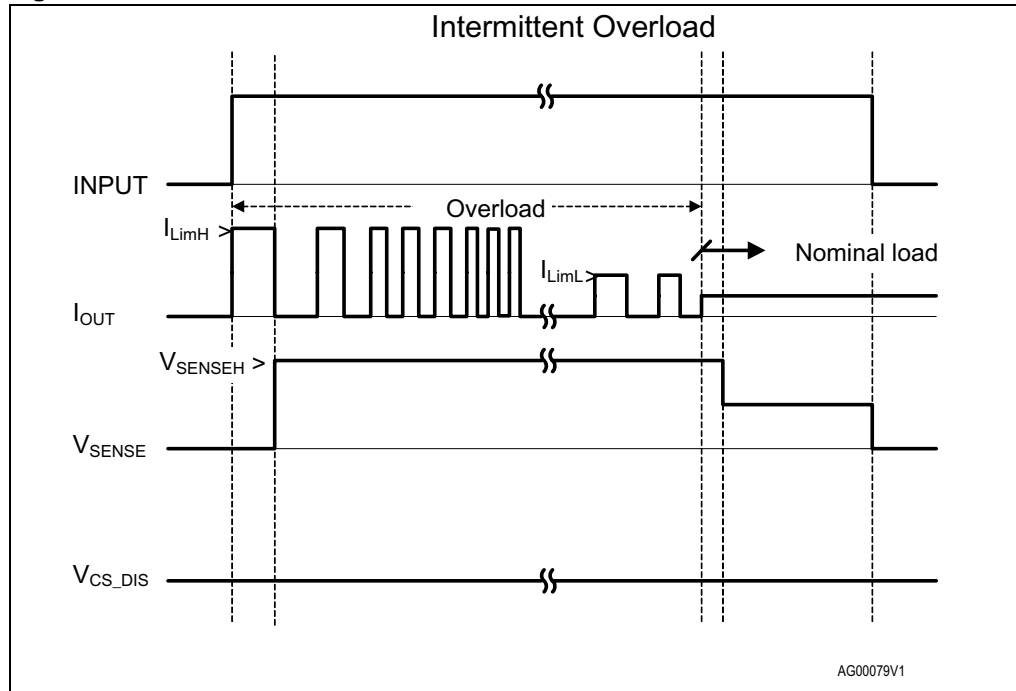

Figure 14. Off-state open-load with external circuitry

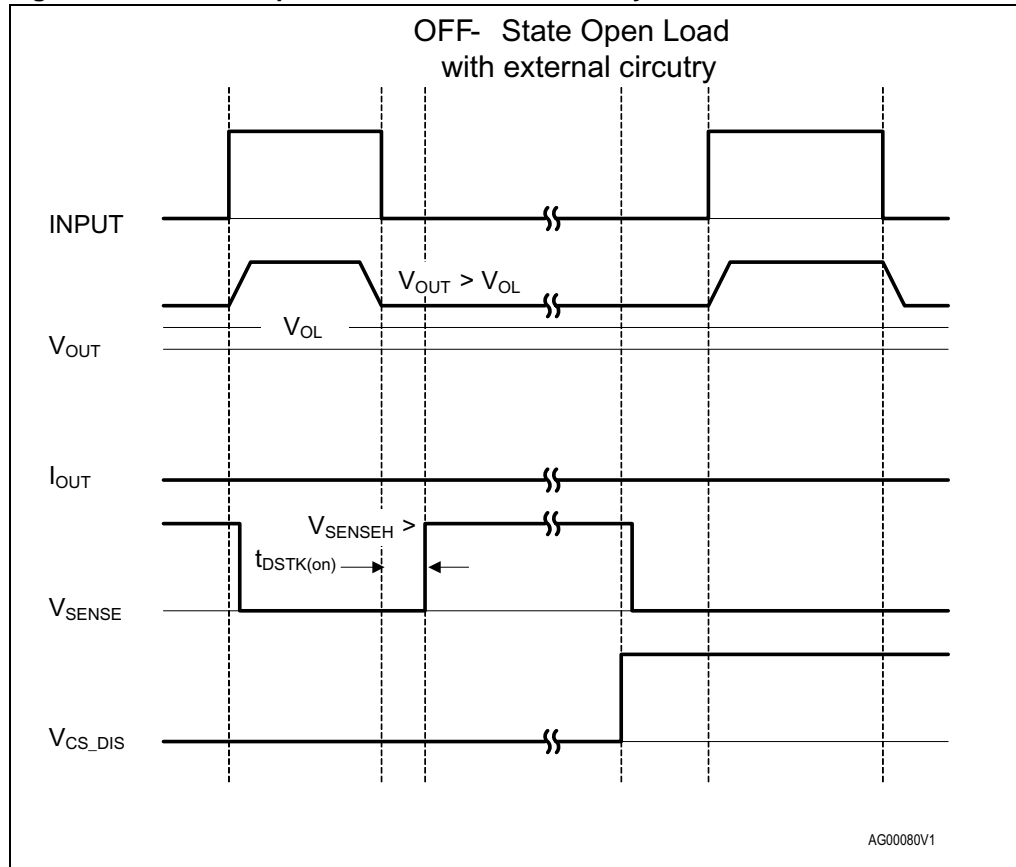

Figure 15. Short to  $V_{CC}$

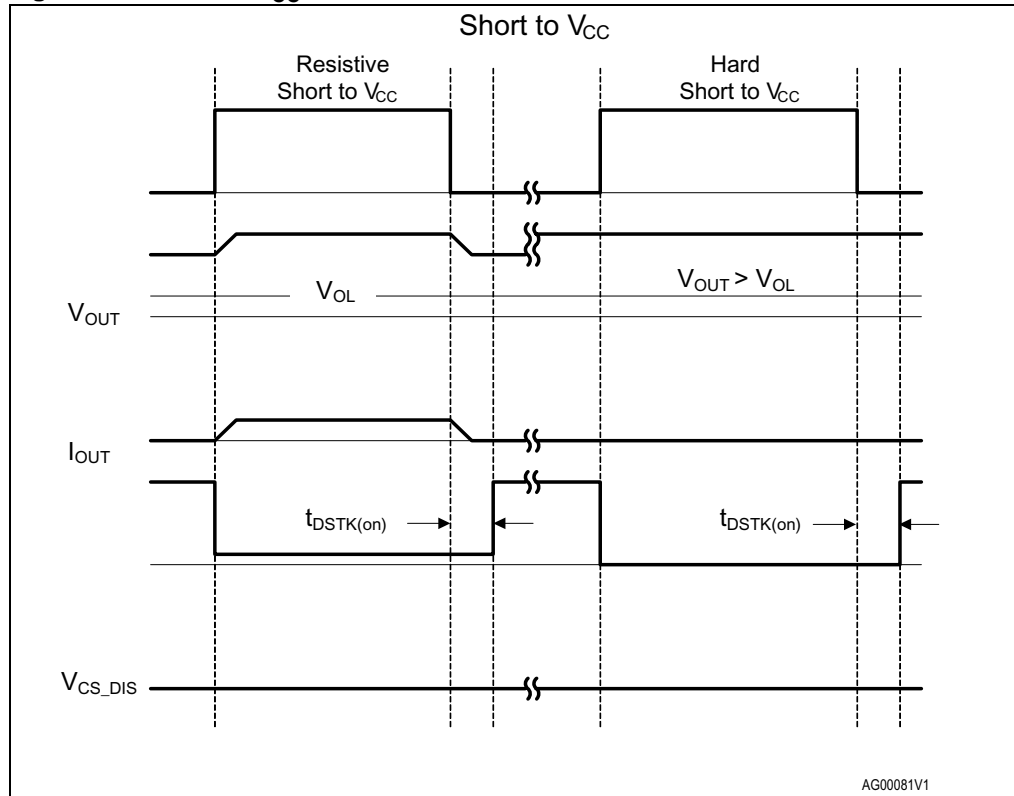
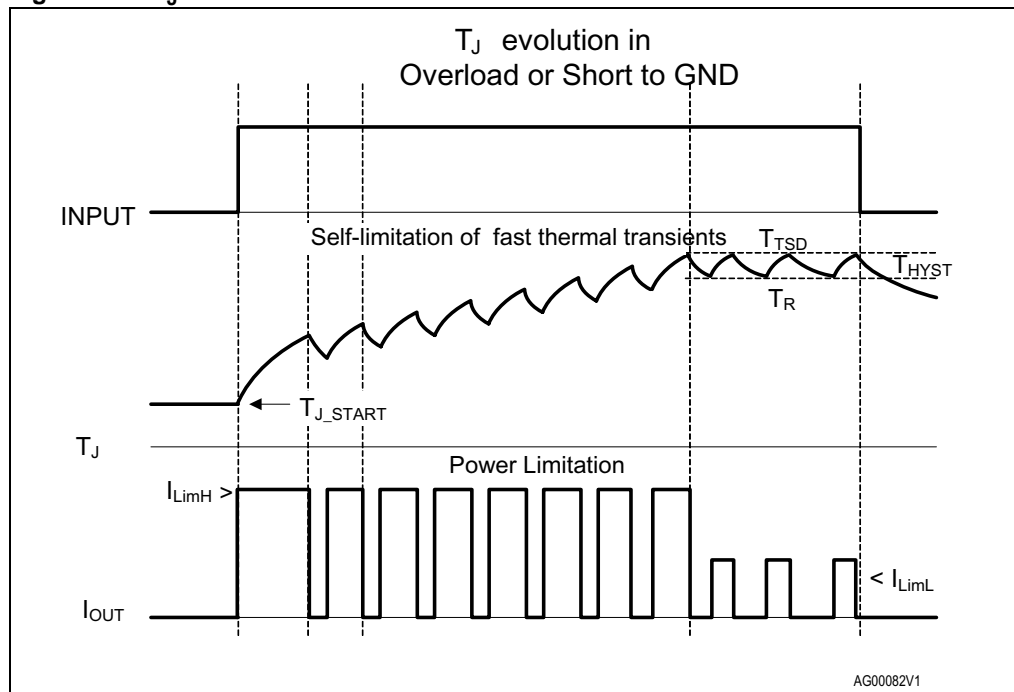

Figure 16.  $T_J$  evolution in overload or short to GND



## 2.5 Electrical characteristics curves

Figure 17. Off-state output current

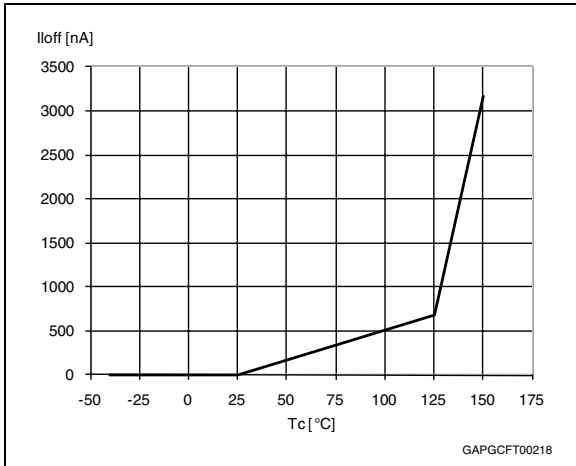

Figure 18. High level input current

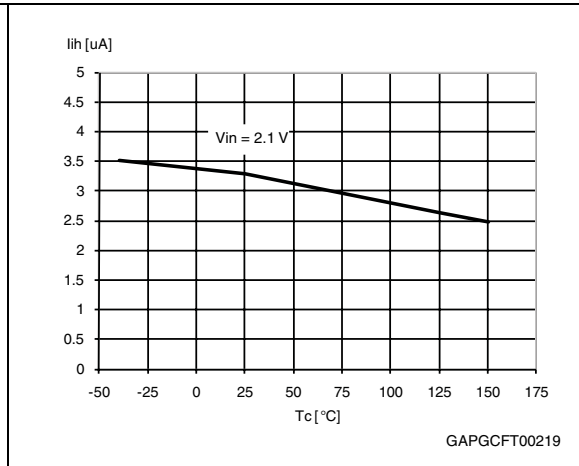

Figure 19. Input clamp voltage

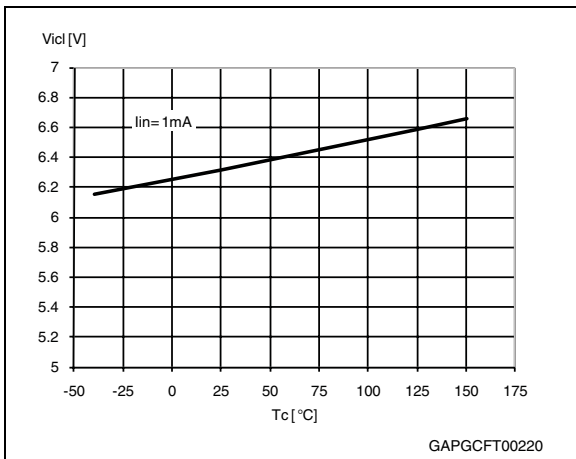

Figure 20. Input high level

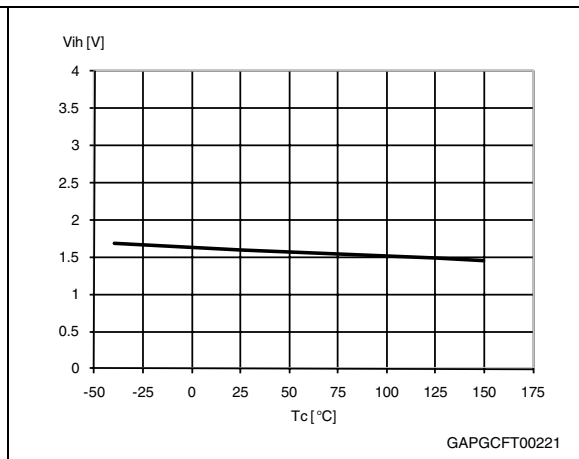

Figure 21. Input low level

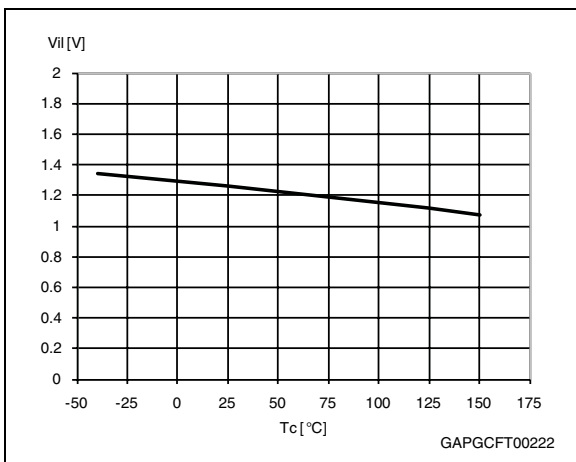

Figure 22. Input hysteresis voltage

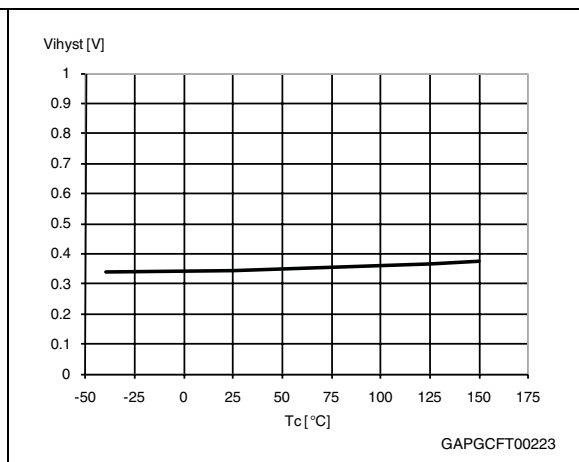

Figure 23. On-state resistance vs  $T_{case}$

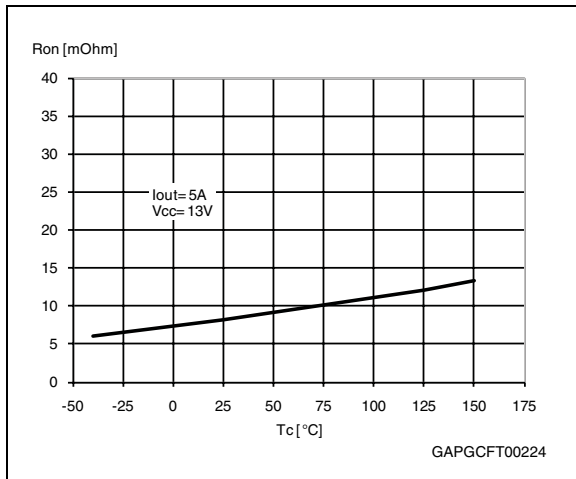

Figure 24. On-state resistance vs  $V_{CC}$

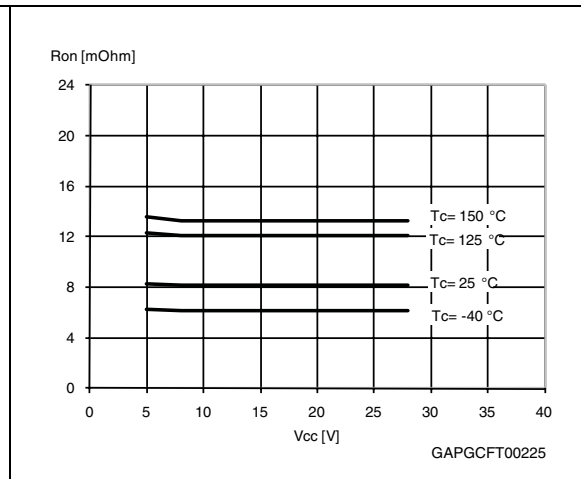

Figure 25. Undervoltage shutdown

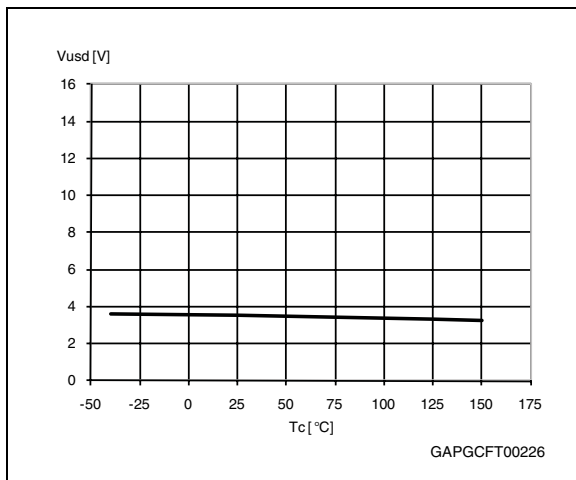

Figure 26.  $I_{LIMH}$  vs  $T_{case}$

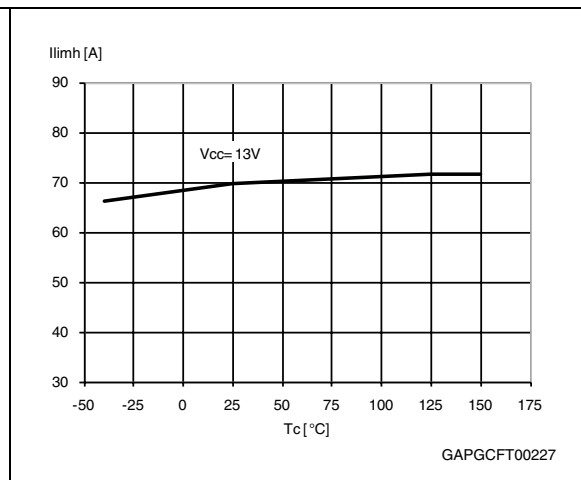

Figure 27. Turn-on voltage slope

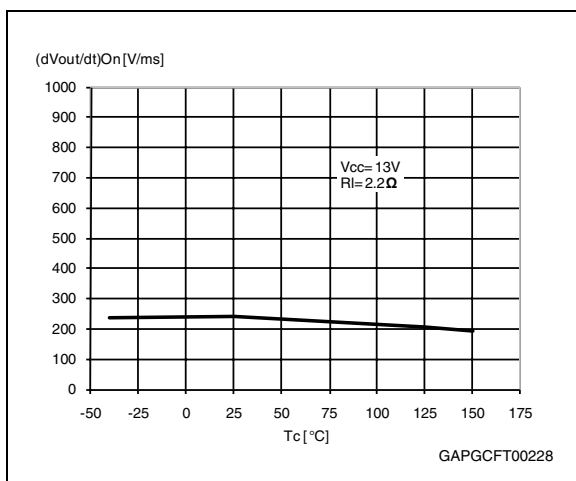

Figure 28. Turn-off voltage slope

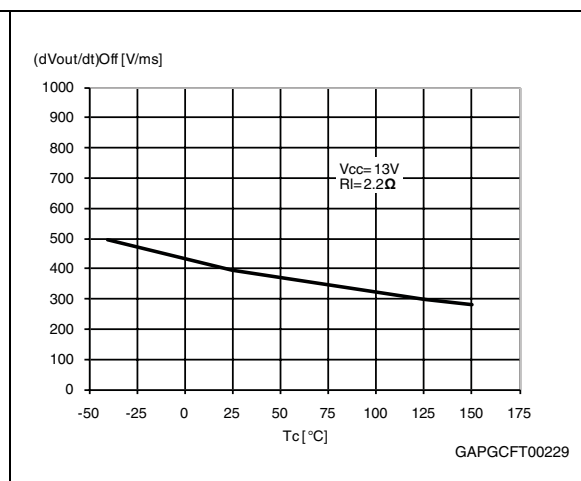

Figure 29. CS\_DIS clamp voltage

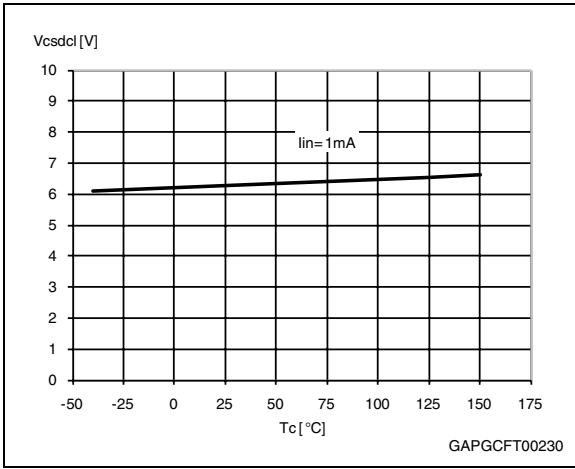

Figure 30. Low level CS\_DIS voltage

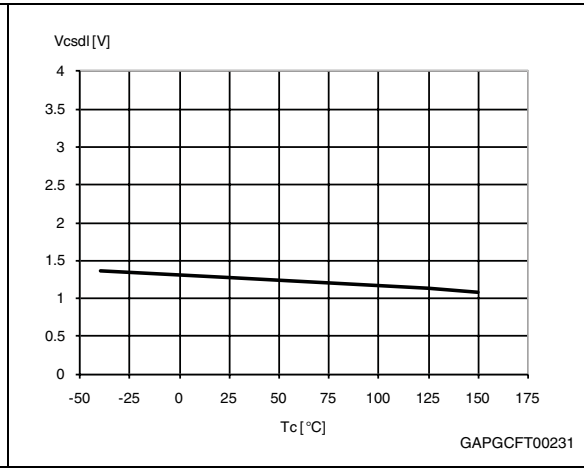
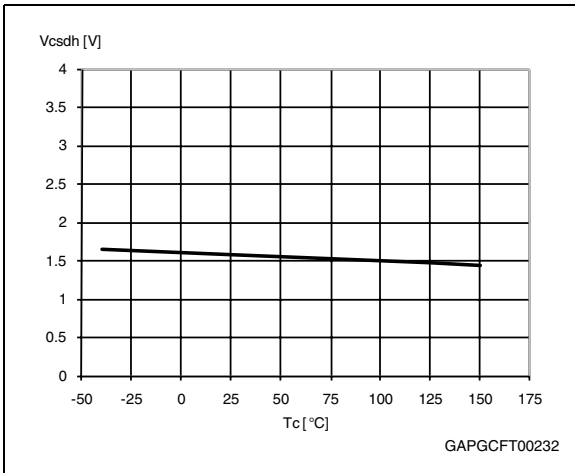

Figure 31. High level CS\_DIS voltage





### 3 Application information

Figure 32. Application schematic

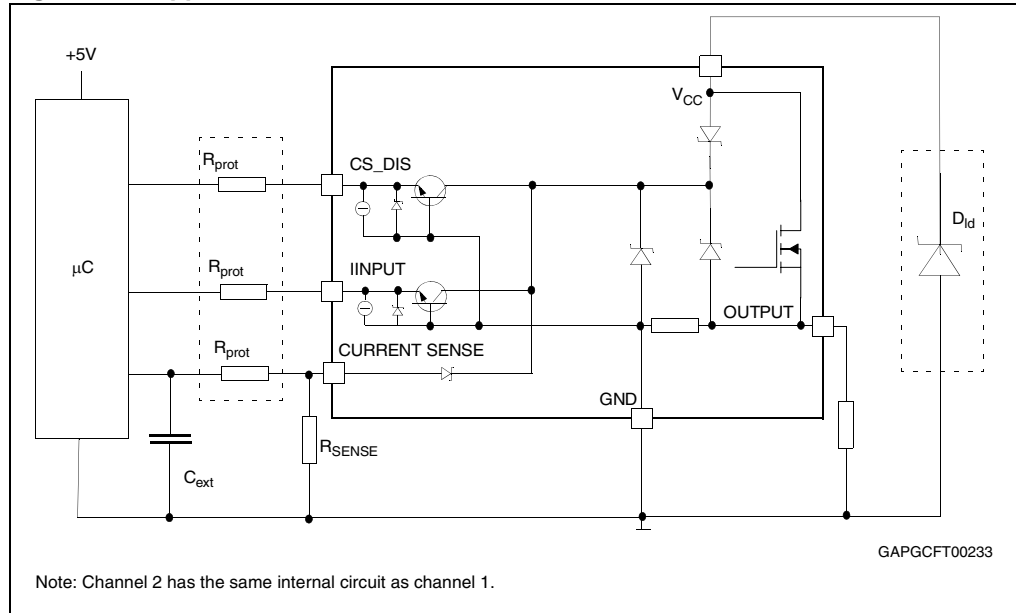

#### 3.1 Load dump protection

$D_{id}$  is necessary (Voltage Transient Suppressor) if the load dump peak voltage exceeds the  $V_{CCPK}$  max rating. The same applies if the device is subject to transients on the  $V_{CC}$  line that are greater than the ones shown in the ISO T/R 7637/1 table.

#### 3.2 MCU I/Os protection

When negative transients are present on the  $V_{CC}$  line, the control pins is pulled negative to approximately -1.5 V. ST suggests to insert a resistor ( $R_{prot}$ ) in line to prevent the microcontroller I/O pins to latch-up.

The value of these resistors is a compromise between the leakage current of microcontroller and the current required by the HSD I/Os (input levels compatibility) with the latch-up limit of microcontroller I/Os.

##### Equation 1:

$$-V_{CCpeak} / I_{latchup} \leq R_{prot} \leq (V_{OH\mu C} - V_{IH}) / I_{IHmax}$$

Calculation example:

For  $V_{CCpeak} = -1.5$  V;  $I_{latchup} \geq 20$  mA;  $V_{OH\mu C} \geq 4.5$  V  
 $75 \Omega \leq R_{prot} \leq 240$  k $\Omega$

Recommended values:  $R_{prot} = 10$  k $\Omega$ ,  $C_{EXT} = 10$  nF.

### 3.3 Current sense and diagnostic

The current sense pin performs a double function (see [Figure 33: Current sense and diagnostic](#)):

- **Current mirror of the load current in normal operation**, delivering a current proportional to the load one according to a known ratio  $K_x$ .  
The current  $I_{SENSE}$  can be easily converted to a voltage  $V_{SENSE}$  by means of an external resistor  $R_{SENSE}$ . Linearity between  $I_{OUT}$  and  $V_{SENSE}$  is ensured up to 5 V minimum (see parameter  $V_{SENSE}$  in [Table 7: Current sense \(8 V <  \$V\_{CC}\$  < 18 V\)](#)). The current sense accuracy depends on the output current (refer to current sense electrical characteristics [Table 7: Current sense \(8 V <  \$V\_{CC}\$  < 18 V\)](#)).
- **Diagnostic flag in fault conditions**, delivering a fixed voltage  $V_{SENSEH}$  up to a maximum current  $I_{SENSEH}$  in case of the following fault conditions (refer to [Table 11: Truth table](#)):
  - Power limitation activation
  - Overtemperature
  - Short to  $V_{CC}$  in off-state
  - Open-load in off-state with additional external components.

A logic level high on CS\_DIS pin sets at the same time all the current sense pins of the device in a high-impedance state, thus disabling the current monitoring and diagnostic detection. This feature allows multiplexing of the microcontroller analog inputs by sharing of sense resistance and ADC line among different devices.

Figure 33. Current sense and diagnostic

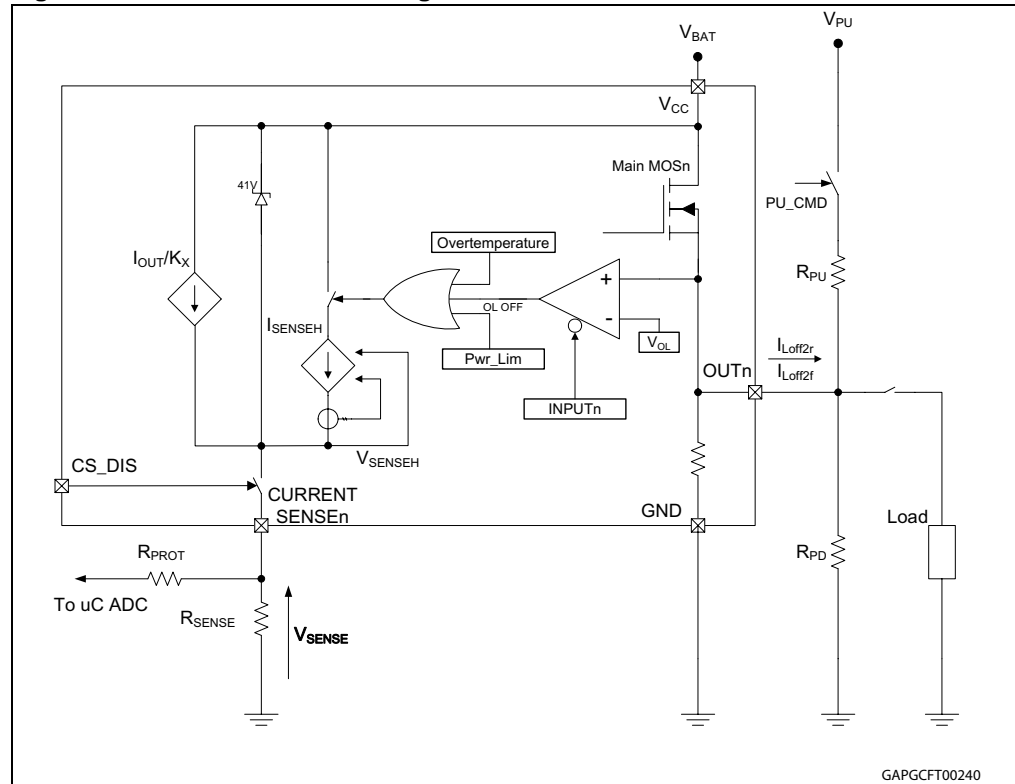

### 3.3.1 Short to $V_{CC}$ and off-state open-load detection

#### Short to $V_{CC}$

A short-circuit between  $V_{CC}$  and output is indicated by the relevant current sense pin set to  $V_{SENSEH}$  during the device off-state. Small or no current is delivered by the current sense during the ON-state depending on the nature of the short-circuit.

#### Off-state open-load with external circuitry

Detection of an open-load in off mode requires an external pull-up resistor  $R_{PU}$  connecting the output to a positive supply voltage  $V_{PU}$ .

It is preferable  $V_{PU}$  to be switched off during the module standby mode in order to avoid the overall standby current consumption to increase in normal conditions, i.e. when load is connected.

An external pull-down resistor  $R_{PD}$  connected between output and GND is mandatory to avoid misdetection in case of floating outputs in off-state (see [Figure 33: Current sense and diagnostic](#)).

$R_{PD}$  must be selected in order to ensure  $V_{OUT} < V_{OLmin}$  unless pulled-up by the external circuitry:

**Equation 2:**

$$V_{OUT}|_{Pull-up\_OFF} = R_{PD} \cdot I_{L(off)2f} < V_{OLmin} = 2V$$

$R_{PD} \leq 22 \text{ k}\Omega$  is recommended.

For proper open-load detection in off-state, the external pull-up resistor must be selected according to the following formula:

**Equation 3:**

$$V_{OUT}|_{Pull-up\_ON} = \frac{(R_{PD} \cdot V_{PU}) - (R_{PU} \cdot R_{PD} \cdot I_{L(off)2r})}{(R_{PU} + R_{PD})} > V_{OLmax} = 4V$$

For the values of  $V_{OLmin}$ ,  $V_{OLmax}$ ,  $I_{L(off)2r}$  and  $I_{L(off)2f}$  (see [Table 8: Open-load detection](#) ( $8V < V_{CC} < 18V$ )).

### 3.4 Maximum demagnetization energy ( $V_{CC} = 13.5 \text{ V}$ )

Figure 34. Maximum turn-off current versus inductance

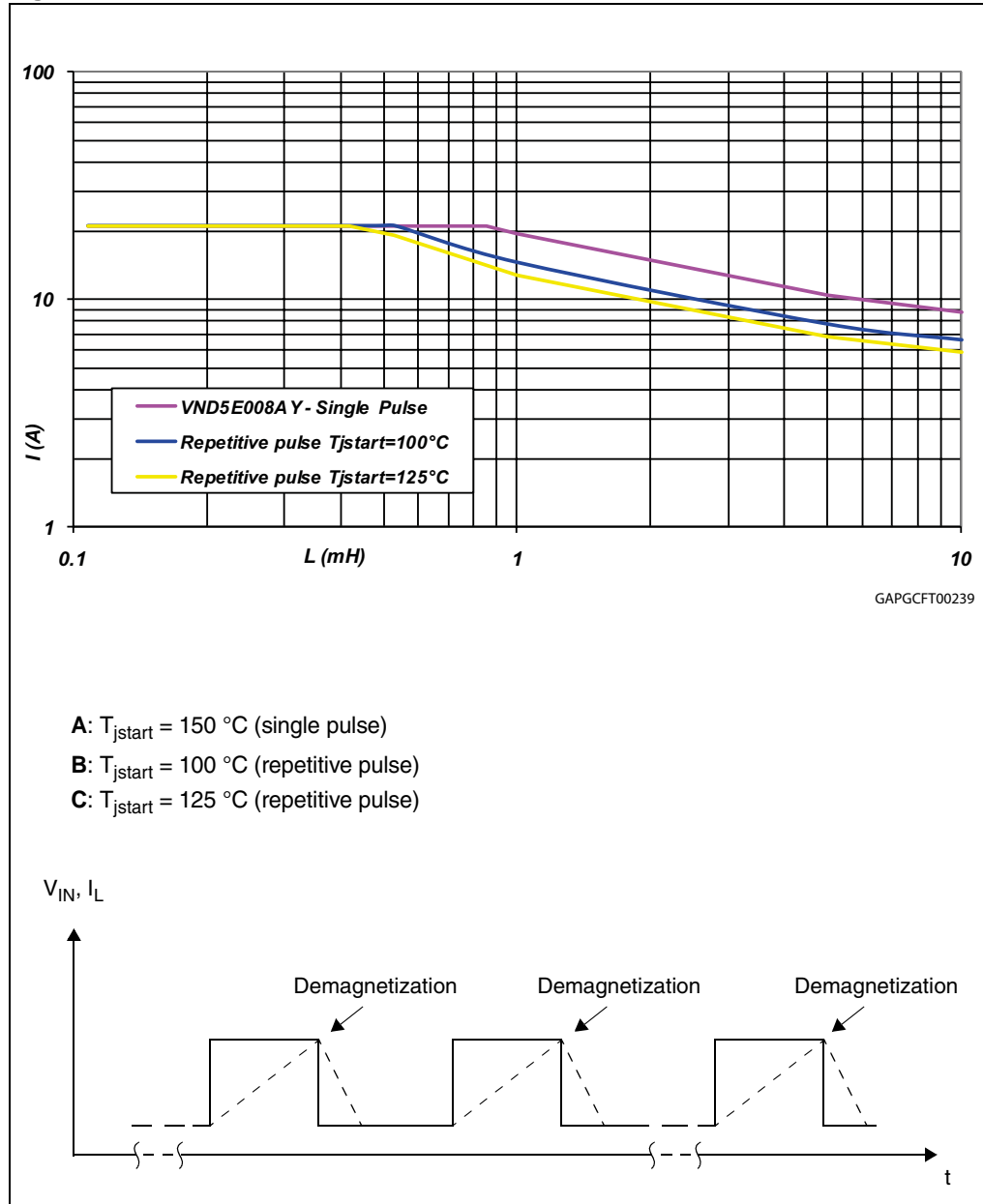

Note: Values are generated with  $R_L = 0 \Omega$ .  
 In case of repetitive pulses,  $T_{jstart}$  (at beginning of each demagnetization) of every pulse must not exceed the temperature specified above for curves A and B.

## 4 Package and PCB thermal data

### 4.1 PowerSSO-36 thermal data

Figure 35. PowerSSO-36 PC board

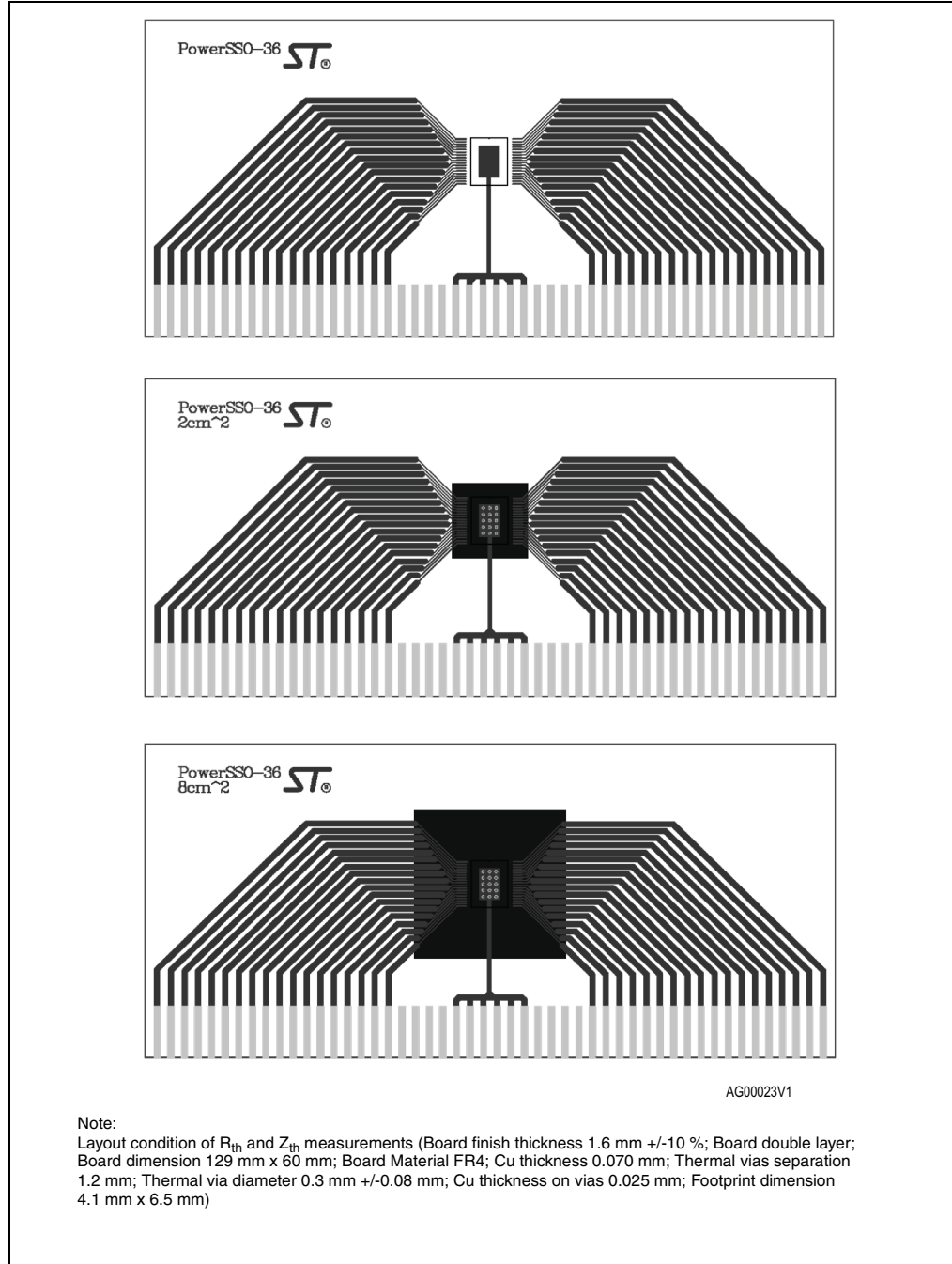

Figure 36.  $R_{thj-amb}$  vs PCB copper area in open box free air condition (one channel ON)

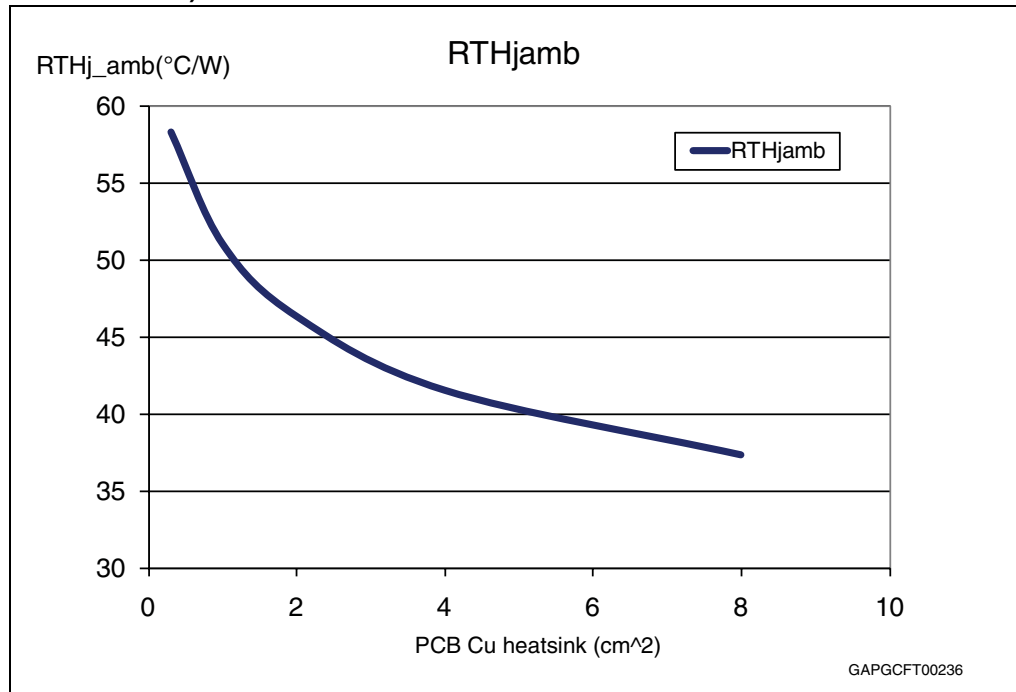

Figure 37. PowerSSO-36 Thermal impedance junction ambient single pulse (one channel ON)

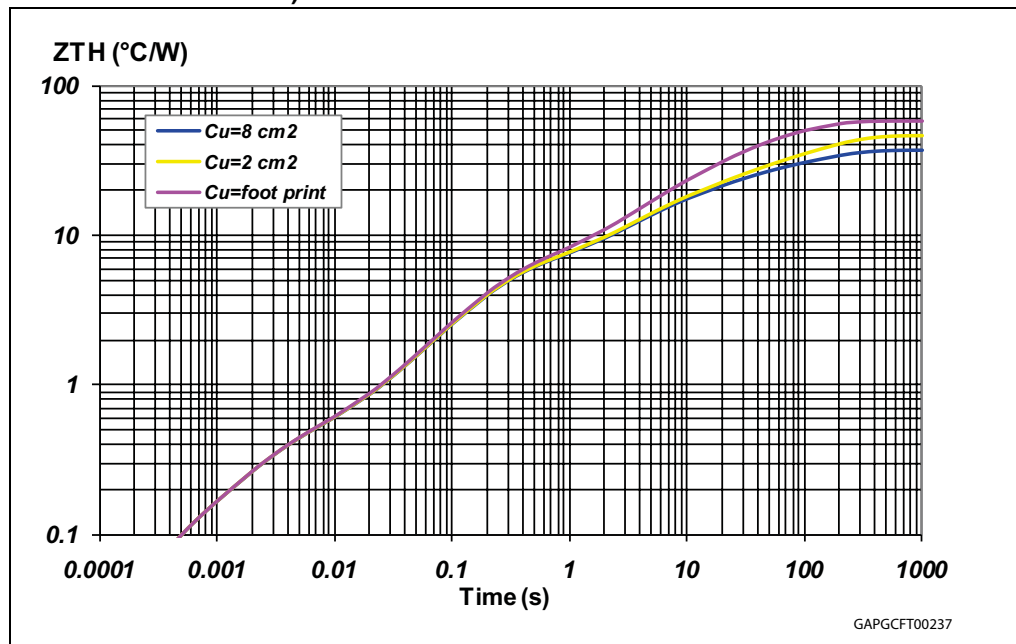
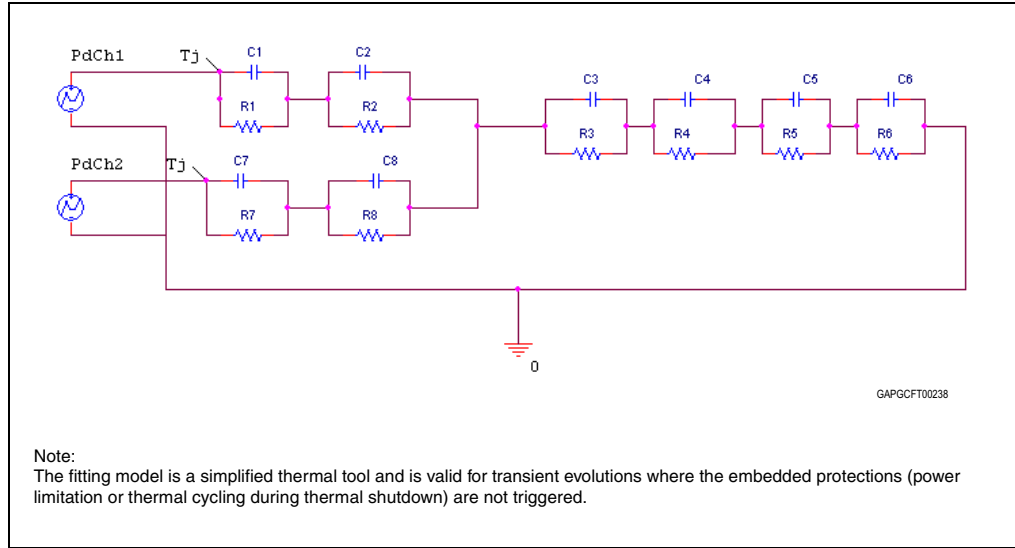

Figure 38. Thermal fitting model of a double channel HSD in PowerSSO-36



Note:  
The fitting model is a simplified thermal tool and is valid for transient evolutions where the embedded protections (power limitation or thermal cycling during thermal shutdown) are not triggered.

Equation 4: pulse calculation formula

$$Z_{TH\delta} = R_{TH} \cdot \delta + Z_{THtp}(1 - \delta)$$

where  $\delta = t_p/T$

Table 15. Thermal parameter

Area/island (cm <sup>2</sup> )	Footprint	2	8
R1 = R7 (°C/W)	0.05		
R2 = R8 (°C/W)	0.3		
R3 (°C/W)	5		
R4 (°C/W)	8		
R5 (°C/W)	18	10	10
R6 (°C/W)	27	23	14
C1 = C7 (W.s/°C)	0.004		
C2 = C8 (W.s/°C)	0.008		
C3 (W.s/°C)	0.04		
C4 (W.s/°C)	0.5		
C5 (W.s/°C)	1	2	2
C6 (W.s/°C)	3	6	9



## 5 Package information

### 5.1 ECOPACK<sup>®</sup> packages

In order to meet environmental requirements, ST offers these devices in different grades of ECOPACK<sup>®</sup> packages, depending on their level of environmental compliance. ECOPACK<sup>®</sup> specifications, grade definitions and product status are available at: [www.st.com](http://www.st.com).

ECOPACK<sup>®</sup> is an ST trademark.

## 5.2 PowerSSO-36 mechanical data

Figure 39. PowerSSO-36 package dimensions

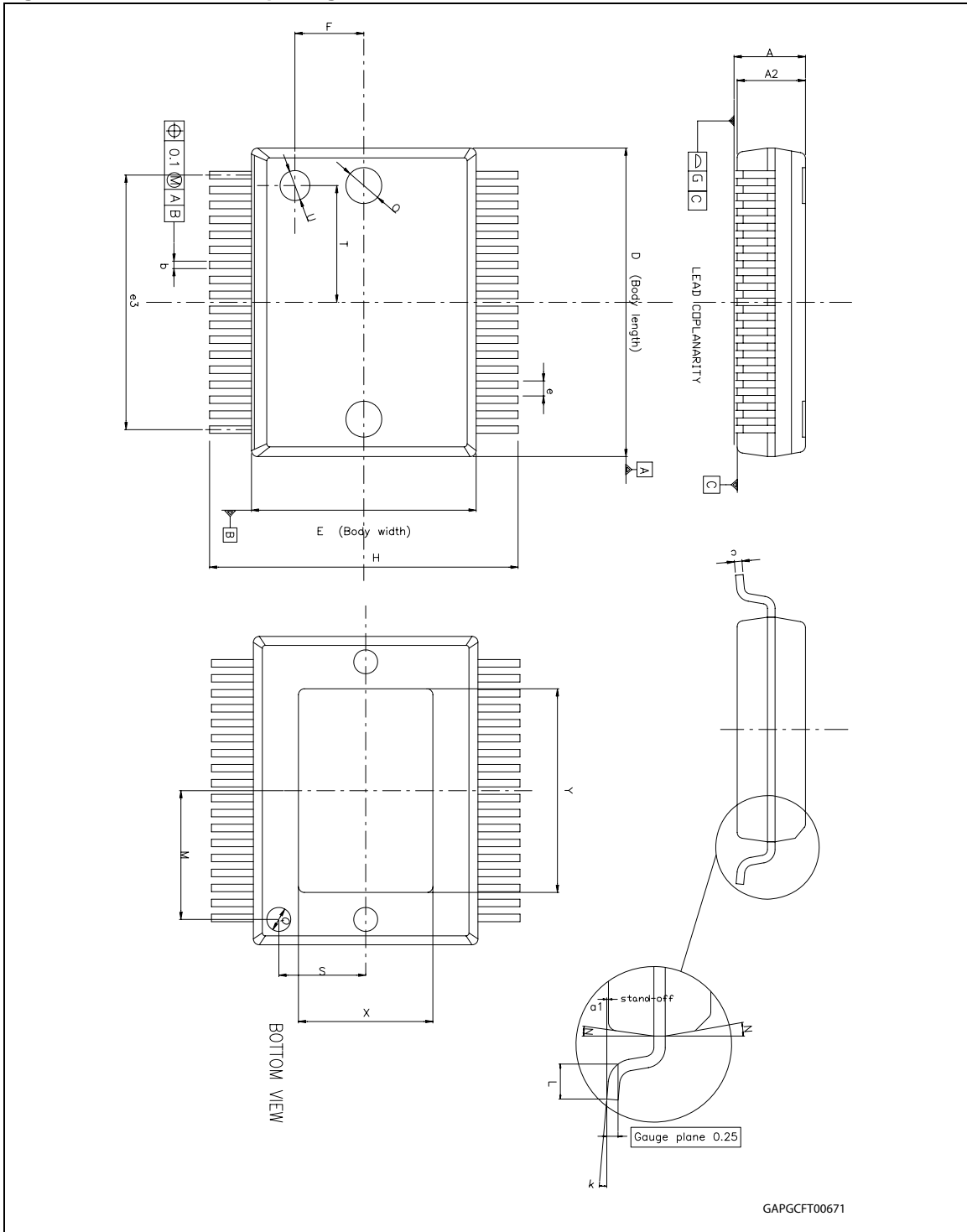

Table 16. PowerSSO-36 mechanical data

Symbol	Millimeters		
	Min.	Typ.	Max.
A	2.15	—	2.47
A2	2.15	—	2.40
a1	0	—	0.075
b	0.18	—	0.36
c	0.23	—	0.32
D	10.10	—	10.50
E	7.4	—	7.6
e	—	0.5	—
e3	—	8.5	—
G	—	—	0.1
G1	—	—	0.06
H	10.1	—	10.5
h	—	—	0.4
L	0.55	—	0.85
N	—	—	10 deg
X	4.1	—	4.7
Y	6.5	—	7.1

### 5.3 Packing information

Figure 40. PowerSSO-36 tube shipment (no suffix)

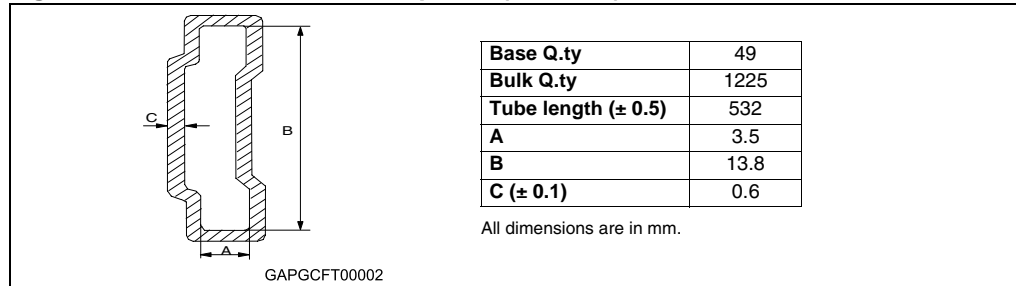
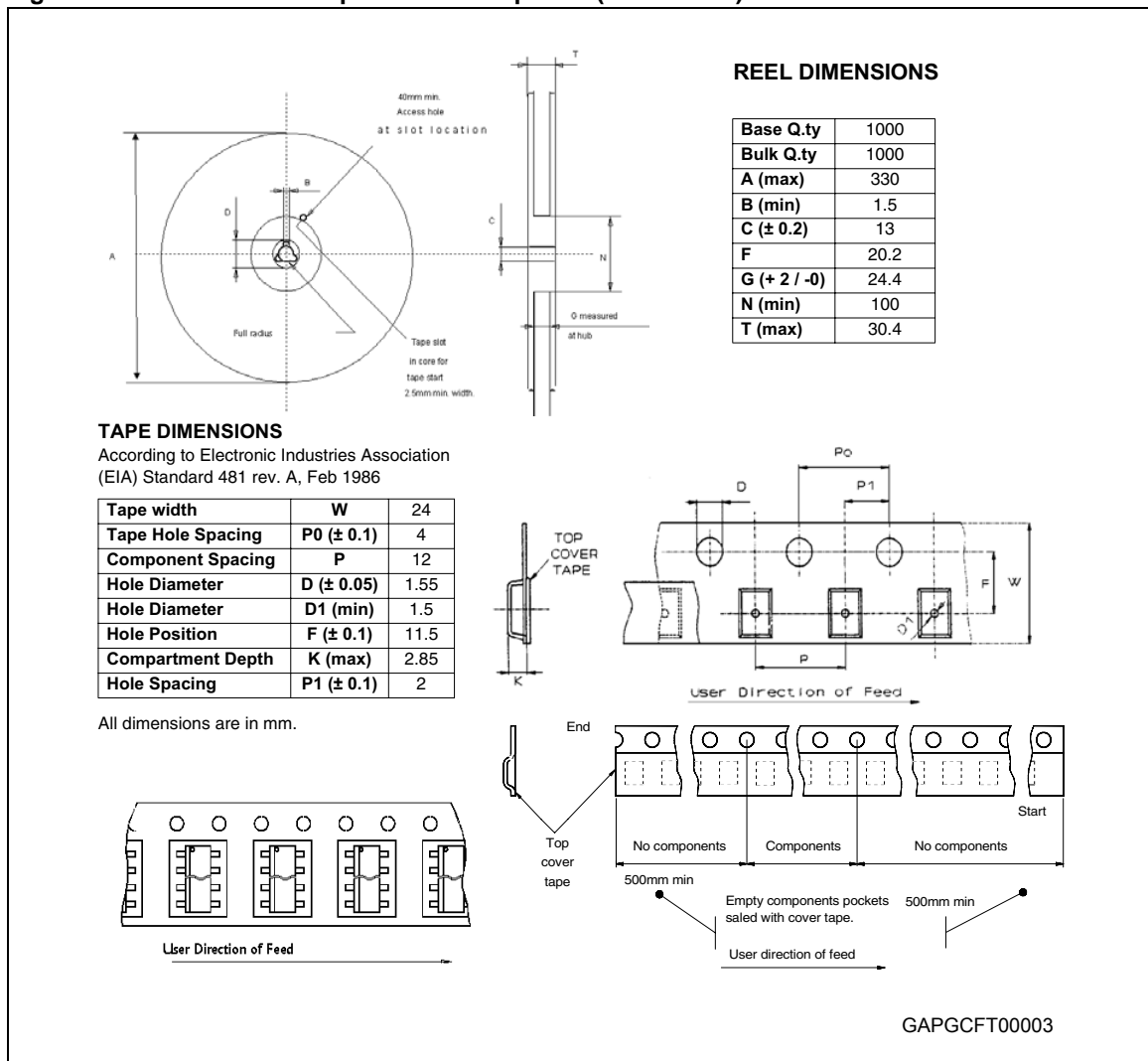

Figure 41. PowerSSO-36 tape and reel shipment (suffix "TR")



## 6 Order codes

Table 17. Device summary

Package	Order codes	
	Tube	Tape and reel
PowerSSO-36	VND5E008AY-E	VND5E008AYTR-E

## 7 Revision history

Table 18. Document revision history

Date	Revision	Changes
05-Jun-2007	1	Initial release
20-Apr-2011	2	<p>Updated <a href="#">Features</a> list.</p> <p>Updated following figures:</p> <ul style="list-style-type: none"> <li>– <a href="#">Figure 1: Block diagram</a></li> <li>– <a href="#">Figure 2: Configuration diagram (top view)</a></li> <li>– <a href="#">Figure 3: Current and voltage conventions</a></li> </ul> <p>Inserted following figures:</p> <ul style="list-style-type: none"> <li>– <a href="#">Figure 6: <math>I_{OUT}/I_{SENSE}</math> vs <math>I_{OUT}</math></a></li> <li>– <a href="#">Figure 7: Maximum current sense ratio drift vs load current</a></li> <li>– <a href="#">Figure 9: Delay response time between rising edge of output current and rising edge of current sense (CS enabled).</a></li> </ul> <p>Updated following tables:</p> <ul style="list-style-type: none"> <li>– <a href="#">Table 1: Pin function</a></li> <li>– <a href="#">Table 2: Suggested connections for unused and not connected pins</a></li> <li>– <a href="#">Table 3: Absolute maximum ratings</a></li> </ul> <p><math>V_{CCPK}</math>, <math>V_{ESD}</math>: updated parameter  <math>V_{CC\_LSC}</math>, <math>-I_{GND}</math>: added parameter  Updated <math>E_{MAX}</math> parameter</p> <ul style="list-style-type: none"> <li>– <a href="#">Table 4: Thermal data</a></li> </ul> <p><math>R_{thj-case}</math>: added value</p> <ul style="list-style-type: none"> <li>– <a href="#">Table 5: Power section</a></li> <li>– <a href="#">Table 6: Switching (<math>V_{CC} = 13V</math>; <math>T_j = 25^{\circ}C</math>)</a></li> <li>– <a href="#">Table 7: Current sense (<math>8 V &lt; V_{CC} &lt; 18 V</math>)</a></li> </ul> <p>Updated <math>dK_1/K_1</math>, <math>dK_2/K_2</math> and <math>dK_3/K_3</math> minimum and maximum values</p> <p><math>V_{SENSEH}</math>, <math>I_{SENSEH}</math>: added note</p> <ul style="list-style-type: none"> <li>– <a href="#">Table 8: Open-load detection (<math>8 V &lt; V_{CC} &lt; 18 V</math>)</a></li> <li>– <a href="#">Table 9: Protections</a></li> </ul> <p>Updated <math>V_{DEMAG}</math> and <math>I_{LIMH}</math> values</p> <ul style="list-style-type: none"> <li>– <a href="#">Table 13: Electrical transient requirements (part 2)</a></li> </ul> <p>Added <a href="#">Section 2.4: Waveforms</a>.</p> <p>Updated <a href="#">Section 2.5: Electrical characteristics curves</a></p> <p>Updated <a href="#">Chapter 3: Application information</a></p> <p>Updated <a href="#">Chapter 4: Package and PCB thermal data</a></p>
12-July-2012	3	Updated <a href="#">Figure 39: PowerSSO-36 package dimensions</a>

**Please Read Carefully:**

Information in this document is provided solely in connection with ST products. STMicroelectronics NV and its subsidiaries ("ST") reserve the right to make changes, corrections, modifications or improvements, to this document, and the products and services described herein at any time, without notice.

All ST products are sold pursuant to ST's terms and conditions of sale.

Purchasers are solely responsible for the choice, selection and use of the ST products and services described herein, and ST assumes no liability whatsoever relating to the choice, selection or use of the ST products and services described herein.

No license, express or implied, by estoppel or otherwise, to any intellectual property rights is granted under this document. If any part of this document refers to any third party products or services it shall not be deemed a license grant by ST for the use of such third party products or services, or any intellectual property contained therein or considered as a warranty covering the use in any manner whatsoever of such third party products or services or any intellectual property contained therein.

**UNLESS OTHERWISE SET FORTH IN ST'S TERMS AND CONDITIONS OF SALE ST DISCLAIMS ANY EXPRESS OR IMPLIED WARRANTY WITH RESPECT TO THE USE AND/OR SALE OF ST PRODUCTS INCLUDING WITHOUT LIMITATION IMPLIED WARRANTIES OF MERCHANTABILITY, FITNESS FOR A PARTICULAR PURPOSE (AND THEIR EQUIVALENTS UNDER THE LAWS OF ANY JURISDICTION), OR INFRINGEMENT OF ANY PATENT, COPYRIGHT OR OTHER INTELLECTUAL PROPERTY RIGHT.**

**UNLESS EXPRESSLY APPROVED IN WRITING BY TWO AUTHORIZED ST REPRESENTATIVES, ST PRODUCTS ARE NOT RECOMMENDED, AUTHORIZED OR WARRANTED FOR USE IN MILITARY, AIR CRAFT, SPACE, LIFE SAVING, OR LIFE SUSTAINING APPLICATIONS, NOR IN PRODUCTS OR SYSTEMS WHERE FAILURE OR MALFUNCTION MAY RESULT IN PERSONAL INJURY, DEATH, OR SEVERE PROPERTY OR ENVIRONMENTAL DAMAGE. ST PRODUCTS WHICH ARE NOT SPECIFIED AS "AUTOMOTIVE GRADE" MAY ONLY BE USED IN AUTOMOTIVE APPLICATIONS AT USER'S OWN RISK.**

Resale of ST products with provisions different from the statements and/or technical features set forth in this document shall immediately void any warranty granted by ST for the ST product or service described herein and shall not create or extend in any manner whatsoever, any liability of ST.

ST and the ST logo are trademarks or registered trademarks of ST in various countries.

Information in this document supersedes and replaces all information previously supplied.

The ST logo is a registered trademark of STMicroelectronics. All other names are the property of their respective owners.

© 2012 STMicroelectronics - All rights reserved

STMicroelectronics group of companies

Australia - Belgium - Brazil - Canada - China - Czech Republic - Finland - France - Germany - Hong Kong - India - Israel - Italy - Japan - Malaysia - Malta - Morocco - Philippines - Singapore - Spain - Sweden - Switzerland - United Kingdom - United States of America

[www.st.com](http://www.st.com)

