

Low Voltage Protection Switch

Features

- ▶ Up to $\pm 20\text{V}$ input voltage protection
- ▶ Low on-resistance - 6.5Ω typical
- ▶ Fast switching speed
- ▶ Effectively, a simple two terminal device
- ▶ No external power supplies needed

Applications

- ▶ Ethernet system protection
- ▶ Resettable fuse
- ▶ High side switch
- ▶ Data acquisition

General Description

The Supertex FP0030 is a 20V current limiting protection device. It is designed to protect Ethernet systems from high transient voltages.

The FP0030 can be considered as a normally closed switch with a typical switch resistance of 6.5Ω . The device starts to turn off when the voltage drop across the two terminals exceeds a nominal value of $\pm 1.5\text{V}$. In the off state, the FP0030 can withstand up to $\pm 20\text{V}$ across its terminals. A small amount of current, typical $800\mu\text{A}$ is allowed to flow through the device.

The FP0030 can also be used as a resettable fuse to protect power lines against output short circuit conditions.

The FP0030 is available in a 3-Lead SOT-23 package.

Typical Application Circuit

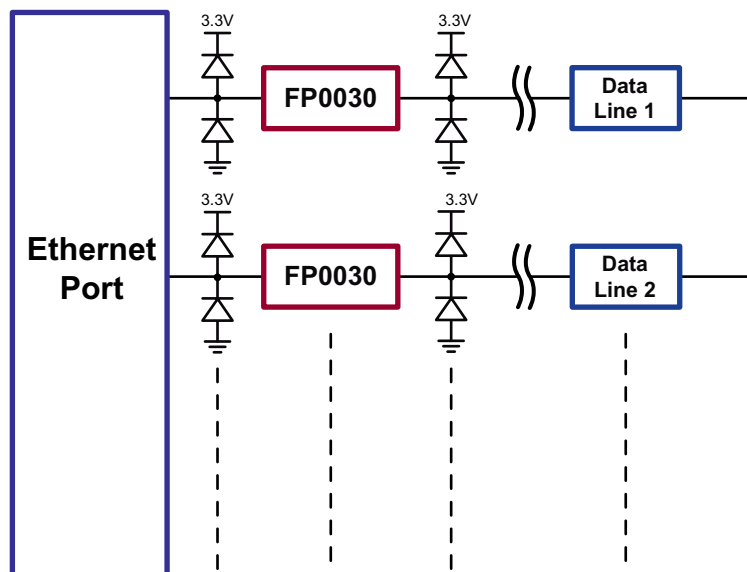

Ordering Information

Part Number	Package	Packing
FP0030K1-G	3-Lead SOT-23	3000/Reel

-G indicates package is RoHS compliant ('Green')



Absolute Maximum Ratings

Parameter	Value
V_{A-B} , Differential voltage drop	0 to $\pm 22V$
Maximum junction temperature	+125°C
Storage temperature range	-65° to +150°C
Power dissipation, $T_A @ 25^\circ C$	360mW ¹

Absolute Maximum Ratings are those values beyond which damage to the device may occur. Functional operation under these conditions is not implied. Continuous operation of the device at the absolute rating level may affect device reliability. All voltages are referenced to device ground.

Note:

1. Mounted on FR4 board, 25mm x 25mm x 1.57mm.

Typical Thermal Resistance

Package	θ_{ja}
3-Lead SOT-23	203°C/W

Pin Configuration



Product Marking

F03W

W = Code for week sealed
 _____ = "Green" Packaging

Package may or may not include the following marks: Si or  **SOT-23 (K1)**

Electrical Characteristics ($T_j = 25^\circ C$ unless otherwise specified)

Sym	Parameter	Min	Typ	Max	Units	Conditions
BV_{A-B}	Differential input voltage range from A to B	± 20	-	-	V	$I_{A-B} = \pm 2.0mA$
R_{SW}	Switch ON-resistance from A to B	-	6.5	8.5	Ω	$I_{A-B} = \pm 50mA$, V_A or $V_B = 0V$
V_{TRIP}	V_{A-B} trip point to turn off	-	± 1.5	-	V	---
V_{OFF}	Switch turn off voltage	-	± 3.2	-	V	$I_{A-B} = \pm 1.0mA$
$I_{A-B(OFF)}$	Switch off current	-	± 800	± 1500	μA	$V_{A-B} = \pm 15V$
I_{PEAK}	Peak switching current	-	± 155	-	mA	---
T_{OFF}	Turn off time	-	30	60	ns	See Figure 1
T_{ON}	Turn on time	-	1.0	2.0	μs	See Figure 2
$C_{SW(ON)}$	Switch ON-capacitance from A to B or B to A	-	32	-	pF	SW = ON
$C_{SW(OFF)}$	Switch OFF-capacitance from A to B or B to A	-	11	-	pF	$V_{SW} = 10V$
T_j	Operating junction temperature	-40	-	+125	$^\circ C$	---

Block Diagram

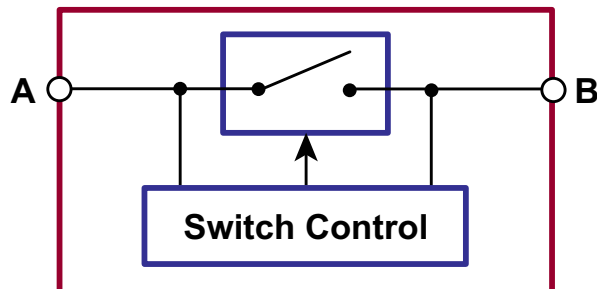

Typical I-V Characteristics

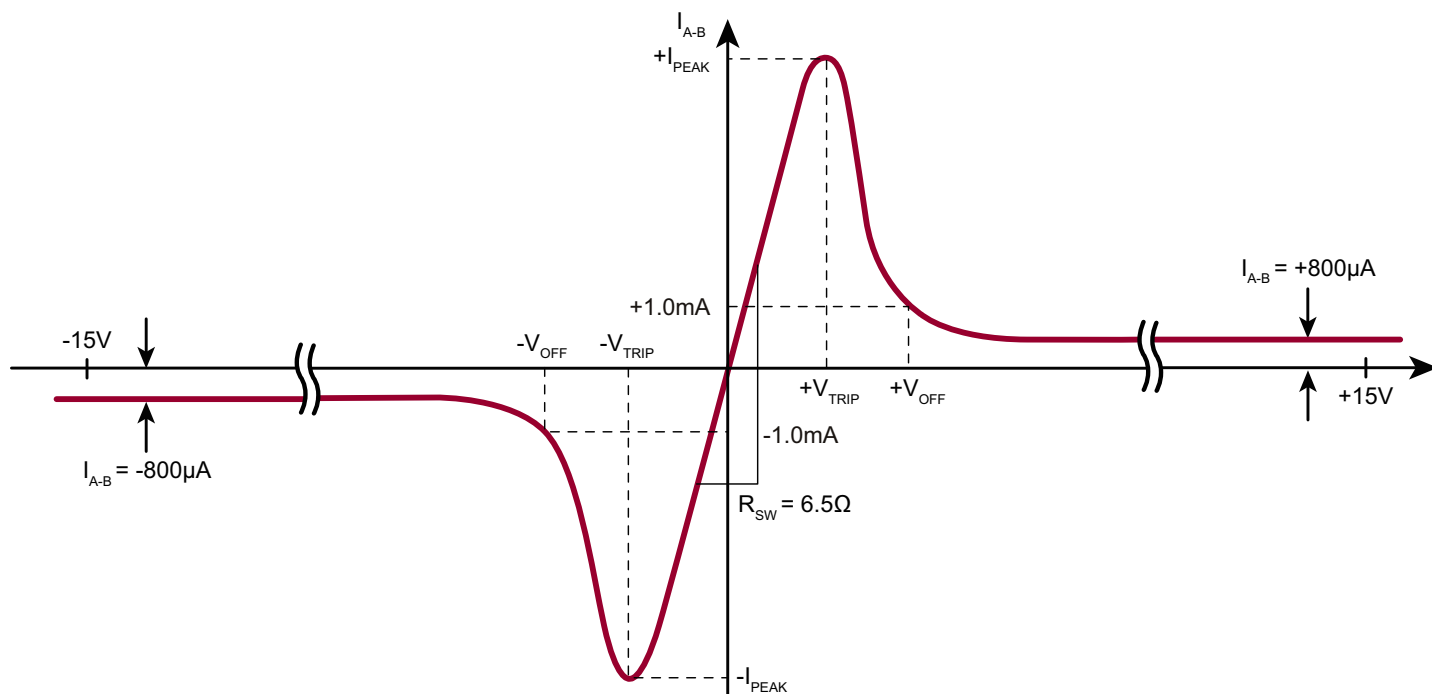

Functional Description

The Supertex FP0030 can be considered as a normally closed switch controlled by a switch control (please refer to the block diagram). The switch control monitors the voltage drop across terminals A and B. If the voltage difference is greater than $\pm 1.5V$, the switch will start to open. Once in the

open state, only a small amount of current, typical $800\mu A$, flows through the switch to detect if the high voltage is still present or not. The switch will not close until the voltage across terminal A and B drops below $\pm 1.5V$.

Test Circuits for T_{ON} and T_{OFF}

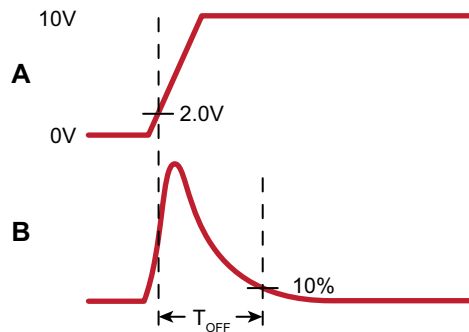
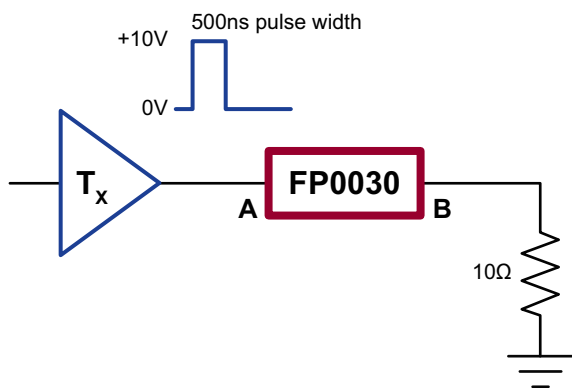

Figure 1: T_{OFF} Test Circuit

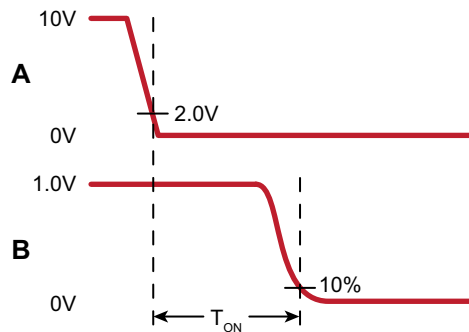
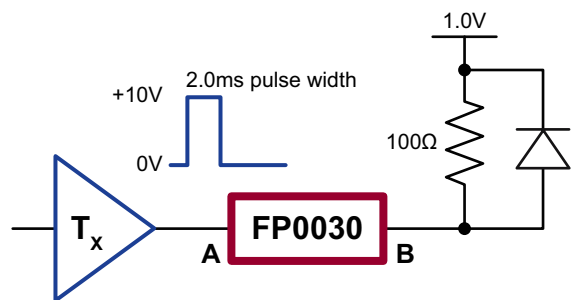

Figure 2: T_{ON} Test Circuit

Pin Description

Pin Name	Description
A	Switch terminal A
SUB	Internally connect to the back of the die. Leave floating. DO NOT GROUND!
B	Switch terminal B

3-Lead TO-236AB (SOT-23) Package Outline (K1)

2.90x1.30mm body, 1.12mm height (max), 1.90mm pitch

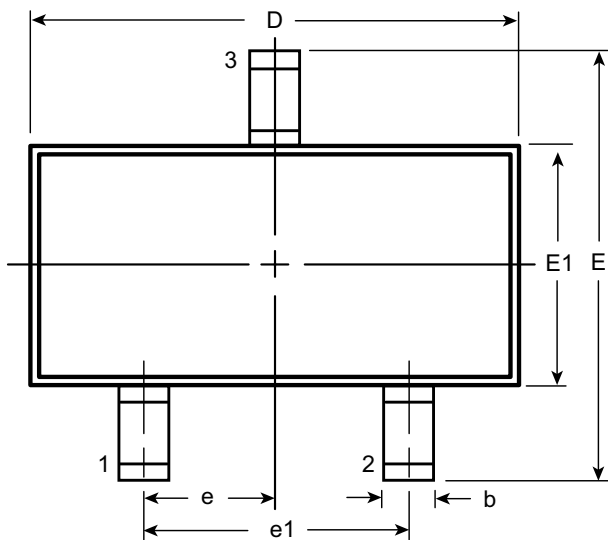

Top View

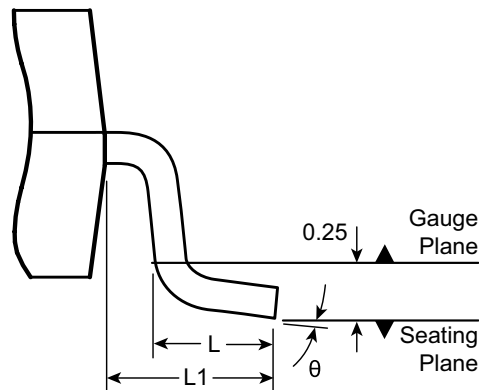

View B

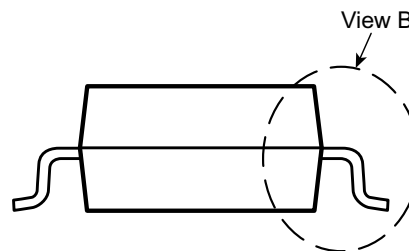
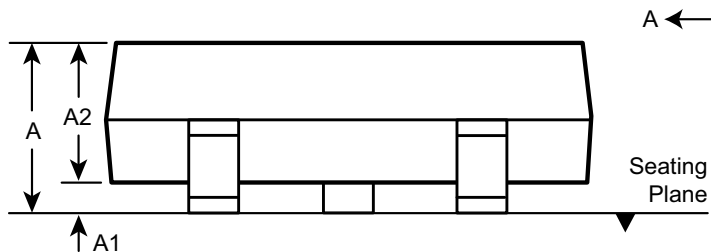

Symbol	A	A1	A2	b	D	E	E1	e	e1	L	L1	θ	
Dimension (mm)	MIN	0.89	0.01	0.88	0.30	2.80	2.10	1.20	0.95 BSC	1.90 BSC	0.20 [†] 0.50 0.60	0.54 REF	0°
	NOM	-	-	0.95	-	2.90	-	1.30					-
	MAX	1.12	0.10	1.02	0.50	3.04	2.64	1.40					8°

JEDEC Registration TO-236, Variation AB, Issue H, Jan. 1999.

[†] This dimension differs from the JEDEC drawing.

Drawings not to scale.

Supertex Doc.#: DSPD-3TO236ABK1, Version C041309.

(The package drawing(s) in this data sheet may not reflect the most current specifications. For the latest package outline information go to <http://www.supertex.com/packaging.html>.)

Supertex inc. does not recommend the use of its products in life support applications, and will not knowingly sell them for use in such applications unless it receives an adequate "product liability indemnification insurance agreement." Supertex inc. does not assume responsibility for use of devices described, and limits its liability to the replacement of the devices determined defective due to workmanship. No responsibility is assumed for possible omissions and inaccuracies. Circuitry and specifications are subject to change without notice. For the latest product specifications refer to the Supertex inc. (website: <http://www.supertex.com>)