

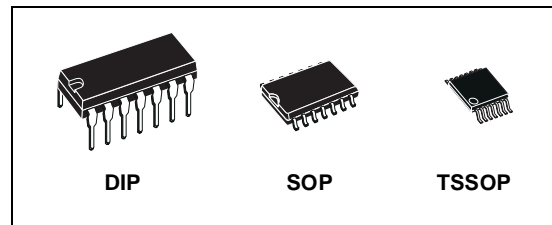

M74HC11

TRIPLE 3-INPUT AND GATE

- HIGH SPEED:
 $t_{PD} = 9\text{ns}$ (TYP.) at $V_{CC} = 6\text{V}$
- LOW POWER DISSIPATION:
 $I_{CC} = 1\mu\text{A}$ (MAX.) at $T_A = 25^\circ\text{C}$
- HIGH NOISE IMMUNITY:
 $V_{NIH} = V_{NIL} = 28\% V_{CC}$ (MIN.)
- SYMMETRICAL OUTPUT IMPEDANCE:
 $|I_{OH}| = I_{OL} = 4\text{mA}$ (MIN)
- BALANCED PROPAGATION DELAYS:
 $t_{PLH} \cong t_{PHL}$
- WIDE OPERATING VOLTAGE RANGE:
 V_{CC} (OPR) = 2V to 6V
- PIN AND FUNCTION COMPATIBLE WITH
 74 SERIES 11



ORDER CODES

| PACKAGE | TUBE | T & R |
|---------|------------|---------------|
| DIP | M74HC11B1R | |
| SOP | M74HC11M1R | M74HC11RM13TR |
| TSSOP | | M74HC11TTR |

DESCRIPTION

The M74HC11 is an high speed CMOS TRIPLE 3-INPUT AND GATE fabricated with silicon gate C²MOS technology.

The internal circuit is composed of 4 stages including buffer output, which enables high noise immunity and stable output.

All inputs are equipped with protection circuits against static discharge and transient excess voltage.

PIN CONNECTION AND IEC LOGIC SYMBOLS

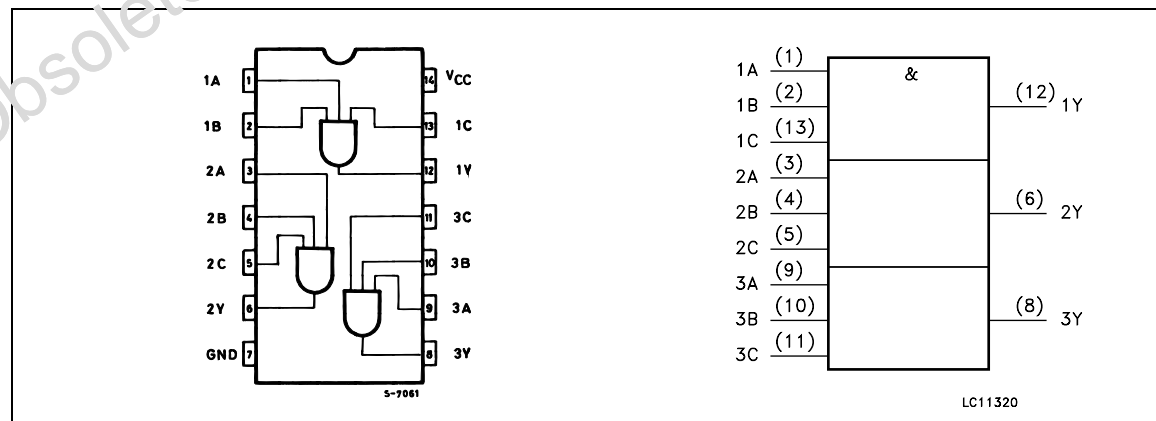

M74HC11

INPUT AND OUTPUT EQUIVALENT CIRCUIT

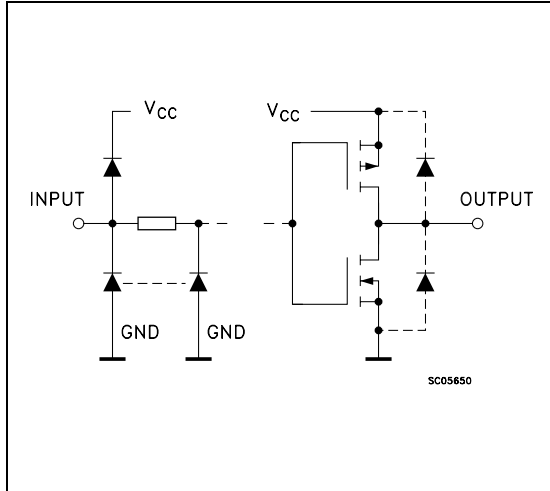

PIN DESCRIPTION

| PIN No | SYMBOL | NAME AND FUNCTION |
|-----------|-----------------|-------------------------|
| 1, 3, 9 | 1A to 3A | Data Inputs |
| 2, 4, 10 | 1B to 3B | Data Inputs |
| 13, 5, 11 | 1C to 3C | Data Inputs |
| 12, 6, 8 | 1Y to 3Y | Data Outputs |
| 7 | GND | Ground (0V) |
| 14 | V _{CC} | Positive Supply Voltage |

TRUTH TABLE

| A | B | C | Y |
|---|---|---|---|
| L | X | X | L |
| X | L | X | L |
| X | X | L | L |
| H | H | H | H |

X : Don't Care

ABSOLUTE MAXIMUM RATINGS

| Symbol | Parameter | Value | Unit |
|-------------------------------------|--------------------------------------|-------------------------------|------|
| V _{CC} | Supply Voltage | -0.5 to +7 | V |
| V _I | DC Input Voltage | -0.5 to V _{CC} + 0.5 | V |
| V _O | DC Output Voltage | -0.5 to V _{CC} + 0.5 | V |
| I _{IK} | DC Input Diode Current | ± 20 | mA |
| I _{OK} | DC Output Diode Current | ± 20 | mA |
| I _O | DC Output Current | ± 25 | mA |
| I _{CC} or I _{GND} | DC V _{CC} or Ground Current | ± 50 | mA |
| P _D | Power Dissipation | 500(*) | mW |
| T _{stg} | Storage Temperature | -65 to +150 | °C |
| T _L | Lead Temperature (10 sec) | 300 | °C |

Absolute Maximum Ratings are those values beyond which damage to the device may occur. Functional operation under these conditions is not implied

(*) 500mW at 65 °C; derate to 300mW by 10mW/°C from 65°C to 85°C

RECOMMENDED OPERATING CONDITIONS

| Symbol | Parameter | Value | Unit | |
|---------------------------------|--------------------------|------------------------|-----------|----|
| V _{CC} | Supply Voltage | 2 to 6 | V | |
| V _I | Input Voltage | 0 to V _{CC} | V | |
| V _O | Output Voltage | 0 to V _{CC} | V | |
| T _{op} | Operating Temperature | -55 to 125 | °C | |
| t _r , t _f | Input Rise and Fall Time | V _{CC} = 2.0V | 0 to 1000 | ns |
| | | V _{CC} = 4.5V | 0 to 500 | ns |
| | | V _{CC} = 6.0V | 0 to 400 | ns |

DC SPECIFICATIONS

| Symbol | Parameter | Test Condition | | Value | | | | | | Unit | |
|-----------------|---------------------------|------------------------|---|-----------------------|------|-------|-------------|------|--------------|------|------|
| | | V _{CC} (V) | | T _A = 25°C | | | -40 to 85°C | | -55 to 125°C | | |
| | | | | Min. | Typ. | Max. | Min. | Max. | Min. | | Max. |
| V _{IH} | High Level Input Voltage | 2.0 | | 1.5 | | | 1.5 | | 1.5 | | V |
| | | 4.5 | | 3.15 | | | 3.15 | | 3.15 | | |
| | | 6.0 | | 4.2 | | | 4.2 | | 4.2 | | |
| V _{IL} | Low Level Input Voltage | 2.0 | | | | 0.5 | | 0.5 | | 0.5 | V |
| | | 4.5 | | | | 1.35 | | 1.35 | | 1.35 | |
| | | 6.0 | | | | 1.8 | | 1.8 | | 1.8 | |
| V _{OH} | High Level Output Voltage | 2.0 | I _O = -20 μA | 1.9 | 2.0 | | 1.9 | | 1.9 | | V |
| | | 4.5 | I _O = -20 μA | 4.4 | 4.5 | | 4.4 | | 4.4 | | |
| | | 6.0 | I _O = -20 μA | 5.9 | 6.0 | | 5.9 | | 5.9 | | |
| | | 4.5 | I _O = -4.0 mA | 4.18 | 4.31 | | 4.13 | | 4.10 | | |
| | | 6.0 | I _O = -5.2 mA | 5.68 | 5.8 | | 5.63 | | 5.60 | | |
| V _{OL} | Low Level Output Voltage | 2.0 | I _O = 20 μA | | 0.0 | 0.1 | | 0.1 | | 0.1 | V |
| | | 4.5 | I _O = 20 μA | | 0.0 | 0.1 | | 0.1 | | 0.1 | |
| | | 6.0 | I _O = 20 μA | | 0.0 | 0.1 | | 0.1 | | 0.1 | |
| | | 4.5 | I _O = 4.0 mA | | 0.17 | 0.26 | | 0.33 | | 0.40 | |
| | | 6.0 | I _O = 5.2 mA | | 0.18 | 0.26 | | 0.33 | | 0.40 | |
| I _I | Input Leakage Current | 6.0 | V _I = V _{CC} or GND | | | ± 0.1 | | ± 1 | | ± 1 | μA |
| I _{CC} | Quiescent Supply Current | 6.0 | V _I = V _{CC} or GND | | | 1 | | 10 | | 20 | μA |

AC ELECTRICAL CHARACTERISTICS (C_L = 50 pF, Input t_r = t_f = 6ns)

| Symbol | Parameter | Test Condition | | Value | | | | | | Unit | |
|-----------------------------------|------------------------|------------------------|--|-----------------------|------|------|-------------|------|--------------|------|------|
| | | V _{CC} (V) | | T _A = 25°C | | | -40 to 85°C | | -55 to 125°C | | |
| | | | | Min. | Typ. | Max. | Min. | Max. | Min. | | Max. |
| t _{TLH} t _{THL} | Output Transition Time | 2.0 | | | 30 | 75 | | 95 | | 110 | ns |
| | | 4.5 | | | 8 | 15 | | 19 | | 22 | |
| | | 6.0 | | | 7 | 13 | | 16 | | 19 | |
| t _{PLH} t _{PHL} | Propagation Delay Time | 2.0 | | | 40 | 85 | | 105 | | 130 | ns |
| | | 4.5 | | | 10 | 17 | | 21 | | 26 | |
| | | 6.0 | | | 9 | 14 | | 18 | | 22 | |

M74HC11

CAPACITIVE CHARACTERISTICS

| Symbol | Parameter | Test Condition | | Value | | | | Unit | | | |
|-----------------|--|---------------------|--|-----------------------|------|------|-------------|------|--------------|------|------|
| | | | | T _A = 25°C | | | -40 to 85°C | | -55 to 125°C | | |
| | | V _{CC} (V) | | Min. | Typ. | Max. | Min. | | Max. | Min. | Max. |
| C _{IN} | Input Capacitance | 5.0 | | | 5 | 10 | | 10 | | 10 | pF |
| C _{PD} | Power Dissipation Capacitance (note 1) | 5.0 | | | 26 | | | | | | pF |

1) C_{PD} is defined as the value of the IC's internal equivalent capacitance which is calculated from the operating current consumption without load. (Refer to Test Circuit). Average operating current can be obtained by the following equation. I_{CC(opr)} = C_{PD} × V_{CC} × f_{IN} + I_{CC}/3 (per gate)

TEST CIRCUIT

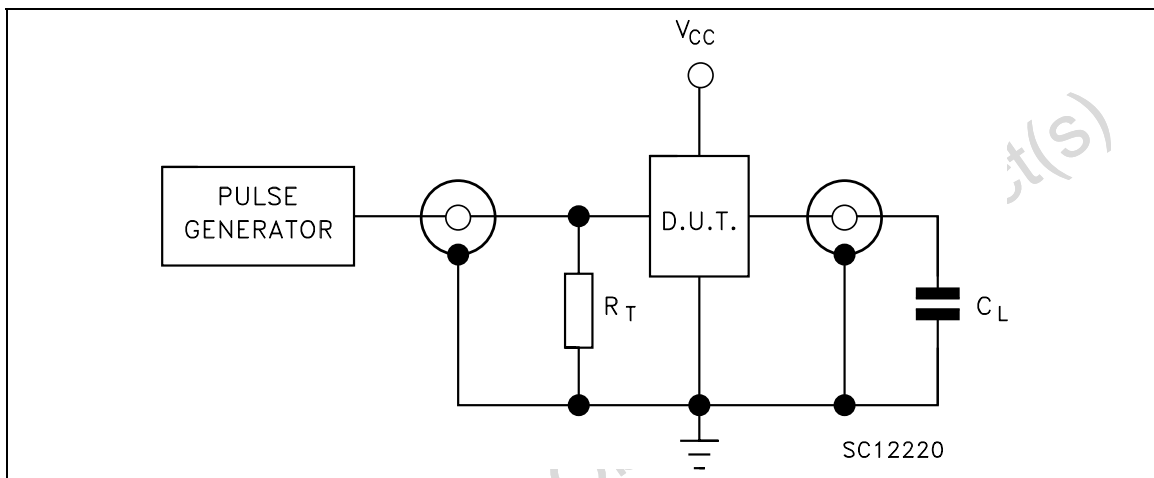

C_L = 50pF or equivalent (includes jig and probe capacitance)
 R_T = Z_{OUT} of pulse generator (typically 50Ω)

WAVEFORM : PROPAGATION DELAY TIME (f=1MHz; 50% duty cycle)

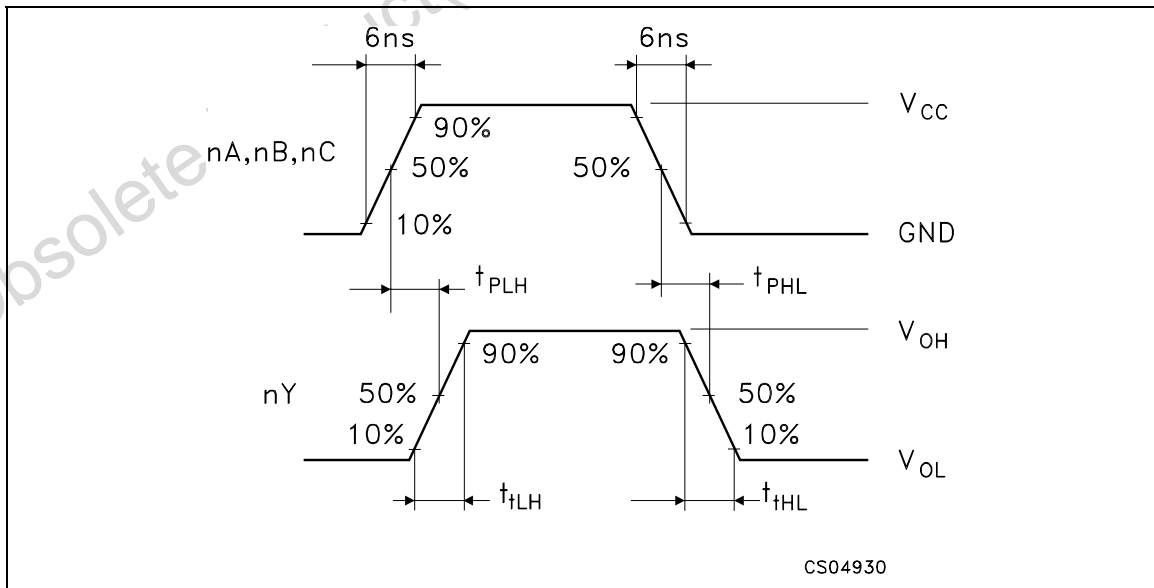

| |
|---------------------------------------|
| Plastic DIP-14 MECHANICAL DATA |
|---------------------------------------|

| DIM. | mm. | | | inch | | |
|------|------|-------|------|-------|-------|-------|
| | MIN. | TYP. | MAX. | MIN. | TYP. | MAX. |
| a1 | 0.51 | | | 0.020 | | |
| B | 1.39 | | 1.65 | 0.055 | | 0.065 |
| b | | 0.5 | | | 0.020 | |
| b1 | | 0.25 | | | 0.010 | |
| D | | | 20 | | | 0.787 |
| E | | 8.5 | | | 0.335 | |
| e | | 2.54 | | | 0.100 | |
| e3 | | 15.24 | | | 0.600 | |
| F | | | 7.1 | | | 0.280 |
| I | | | 5.1 | | | 0.201 |
| L | | 3.3 | | | 0.130 | |
| Z | 1.27 | | 2.54 | 0.050 | | 0.100 |

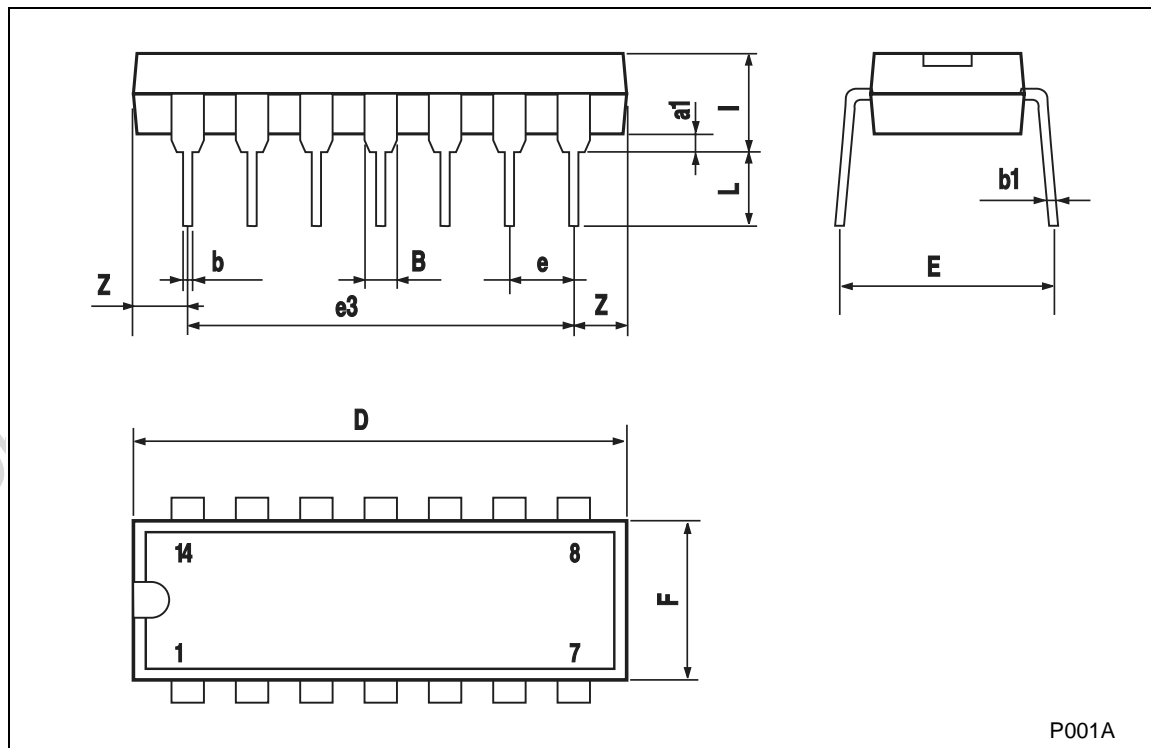

SO-14 MECHANICAL DATA

| DIM. | mm. | | | inch | | |
|------|------------|------|------|-------|-------|-------|
| | MIN. | TYP. | MAX. | MIN. | TYP. | MAX. |
| A | | | 1.75 | | | 0.068 |
| a1 | 0.1 | | 0.2 | 0.003 | | 0.007 |
| a2 | | | 1.65 | | | 0.064 |
| b | 0.35 | | 0.46 | 0.013 | | 0.018 |
| b1 | 0.19 | | 0.25 | 0.007 | | 0.010 |
| C | | 0.5 | | | 0.019 | |
| c1 | 45° (typ.) | | | | | |
| D | 8.55 | | 8.75 | 0.336 | | 0.344 |
| E | 5.8 | | 6.2 | 0.228 | | 0.244 |
| e | | 1.27 | | | 0.050 | |
| e3 | | 7.62 | | | 0.300 | |
| F | 3.8 | | 4.0 | 0.149 | | 0.157 |
| G | 4.6 | | 5.3 | 0.181 | | 0.208 |
| L | 0.5 | | 1.27 | 0.019 | | 0.050 |
| M | | | 0.68 | | | 0.026 |
| S | 8° (max.) | | | | | |

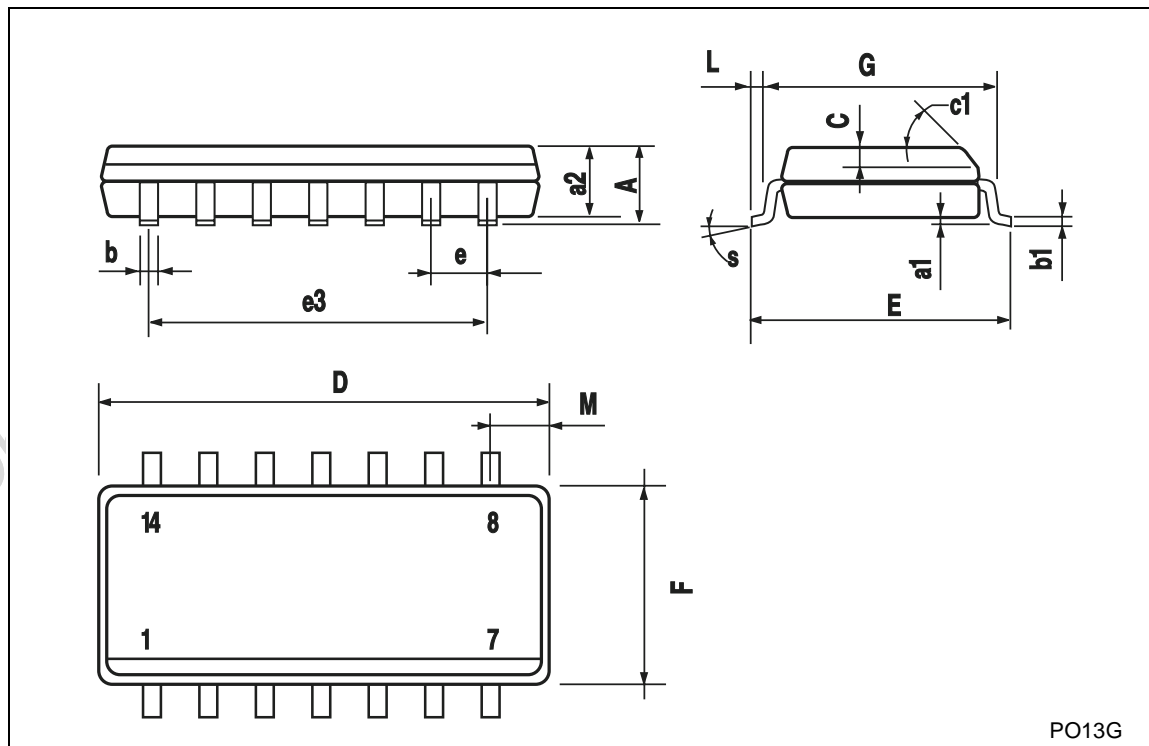

PO13G

TSSOP14 MECHANICAL DATA

| DIM. | mm. | | | inch | | |
|------|------|----------|------|-------|------------|--------|
| | MIN. | TYP | MAX. | MIN. | TYP. | MAX. |
| A | | | 1.2 | | | 0.047 |
| A1 | 0.05 | | 0.15 | 0.002 | 0.004 | 0.006 |
| A2 | 0.8 | 1 | 1.05 | 0.031 | 0.039 | 0.041 |
| b | 0.19 | | 0.30 | 0.007 | | 0.012 |
| c | 0.09 | | 0.20 | 0.004 | | 0.0089 |
| D | 4.9 | 5 | 5.1 | 0.193 | 0.197 | 0.201 |
| E | 6.2 | 6.4 | 6.6 | 0.244 | 0.252 | 0.260 |
| E1 | 4.3 | 4.4 | 4.48 | 0.169 | 0.173 | 0.176 |
| e | | 0.65 BSC | | | 0.0256 BSC | |
| K | 0° | | 8° | 0° | | 8° |
| L | 0.45 | 0.60 | 0.75 | 0.018 | 0.024 | 0.030 |

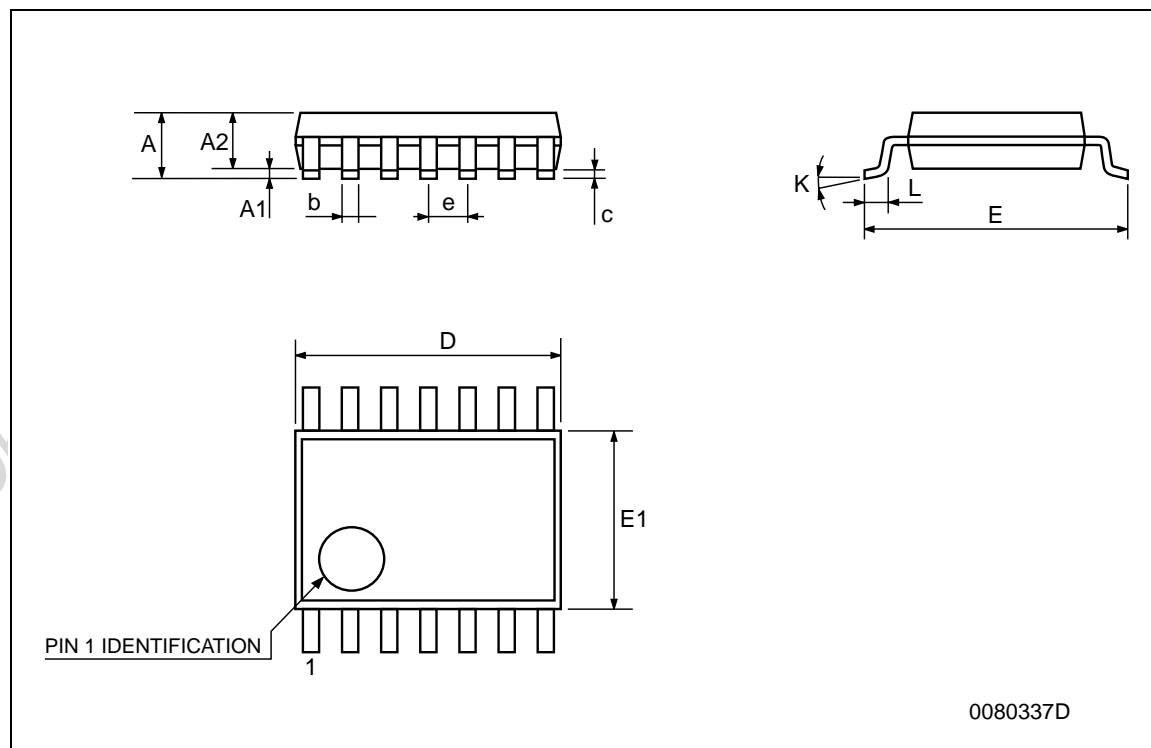

Obsolete Product(s) - Obsolete Product(s)

Information furnished is believed to be accurate and reliable. However, STMicroelectronics assumes no responsibility for the consequences of use of such information nor for any infringement of patents or other rights of third parties which may result from its use. No license is granted by implication or otherwise under any patent or patent rights of STMicroelectronics. Specifications mentioned in this publication are subject to change without notice. This publication supersedes and replaces all information previously supplied. STMicroelectronics products are not authorized for use as critical components in life support devices or systems without express written approval of STMicroelectronics.

© The ST logo is a registered trademark of STMicroelectronics

© 2001 STMicroelectronics - Printed in Italy - All Rights Reserved
STMicroelectronics GROUP OF COMPANIES

Australia - Brazil - China - Finland - France - Germany - Hong Kong - India - Italy - Japan - Malaysia - Malta - Morocco
Singapore - Spain - Sweden - Switzerland - United Kingdom

© <http://www.st.com>