

Data Sheet

Rev. 1.2 / August 2011

ZLED7030

High Current 40V LED Driver with Switch Dimming



ZLED7030

High Current 40V LED Driver with Switch Dimming

ZMDI[®]

The Analog Mixed Signal Company



Brief Description

The ZLED7x30 continuous-mode inductive step-down converter family is one of our ZLED LED-control ICs. It is designed for applications requiring high brightness and high current. The ZLED7x30 can efficiently drive a single LED or multiple series-connected LEDs from a voltage input higher than the LED forward voltage ($V_{in} = 8.5$ to 40VDC). It provides an adjustable output current (1.2A maximum), which is set via an external resistor and controlled by the ZLED7x30's integrated high-side output current-sensing circuit and high speed internal 40V power switch. Its low conducting impedance ensures high system efficiency.

The ZLED7x30 provides a switch dimming function. It detects external switch action to adjust output current, allowing dimming functionality to be achieved without changing the original lighting system circuitry.

The switch dimming is implemented in either two-level mode or three-level mode. The output current of every level and the total number of levels are customer selected by setting the corresponding input conditions of DIM1 and DIM2 pin.

The ZLED7x30 enables diverse industrial and consumer lighting applications requiring high driving currents, wide operating voltage range, high efficiency, and variable brightness control. It offers over-temperature and LED open-circuit protection. The ZLED7x30 can also minimize bill-of-material costs because very few external components are required for most applications. Only a resistor, a diode, an inductor, and three capacitors are needed for a typical basic application.

Features

- Switch dimming with multiple levels
- Three modes for output level settings
- Up to 1.2A output current
- Internal 40V power switch
- Wide DC input voltage range 8.5 to 40 VDC
- Output current accuracy: 5% (typical)
- LED open-circuit protection
- Thermal shutdown protection

Benefits

- High efficiency: up to 98%
- Very few external components needed for operation
- Adds switch dimming function to existing installation

Available Support

- Evaluation Kit

Physical Characteristics

- Operating temperature: -40°C to 105°C
- Switching frequency: up to 1MHz
- SOP-8 package

ZLED7x30 Family Selection Matrix		
Product	Max. Current Output	Package
ZLED7030	1.2A	SOP-8
ZLED7330	1.0A	SOP-8
ZLED7530	0.75A	SOP-8
ZLED7730	0.35A	SOP-8

ZLED7x30 Typical Application Circuit

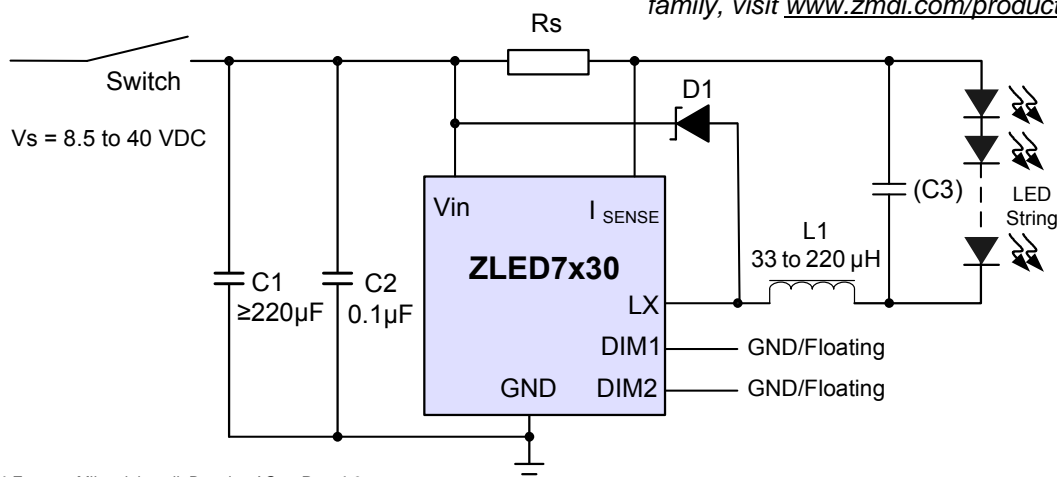

For additional information on our ZLED driver family, visit www.zmdi.com/products/led-drivers/

ZLED7030

High Current 40V LED Driver with Switch Dimming



The Analog Mixed Signal Company



ZLED7x30 Block Diagram

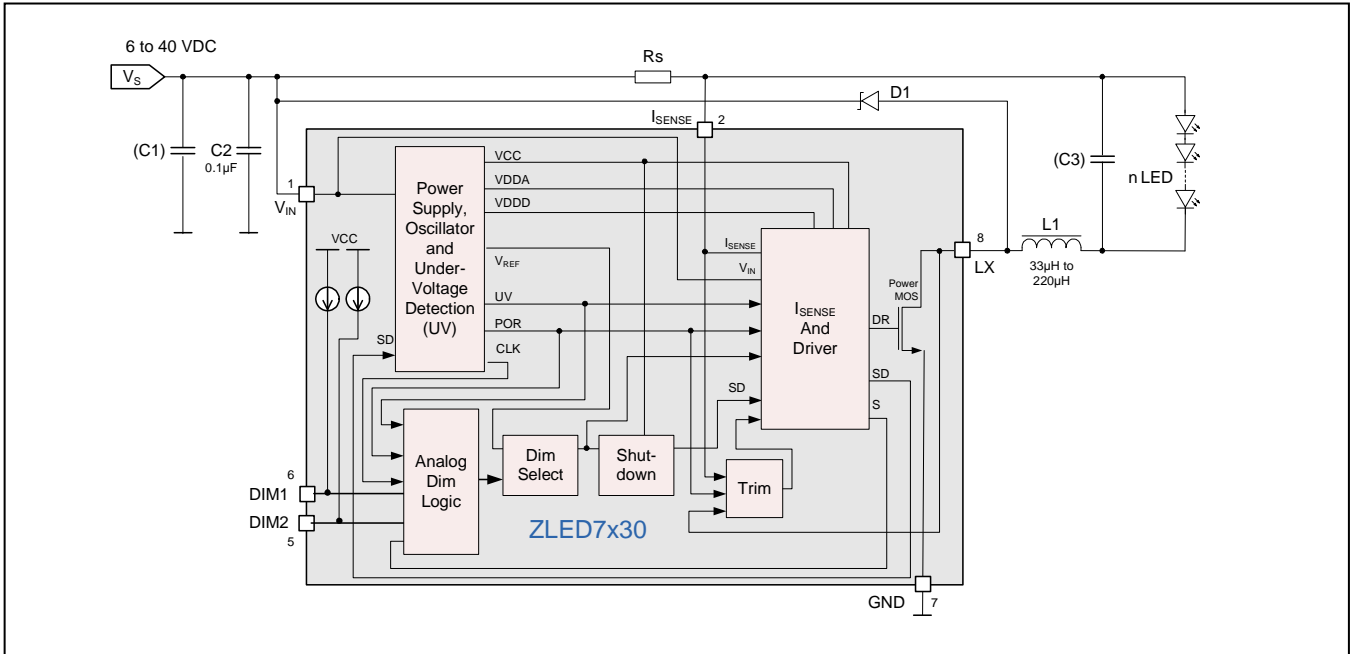

Typical Applications

- ❖ Illuminated LED signs and other displays
- ❖ LED street and traffic lighting (low voltage)
- ❖ Architecture/building LED lighting
- ❖ LED backlighting
- ❖ Interior/exterior LED lighting
- ❖ MR16 LED spot lights
- ❖ Retrofit LED lighting fixtures
- ❖ General purpose industrial and consumer LED applications

Ordering Information

Product Sales Code	Description	Package
ZLED7030-ZI1R	ZLED7030 – High Current (1200mA) 40V LED Driver with Switch Dimming	SOP-8 (Tape & Reel)
ZLED7330-ZI1R	ZLED7330 – High Current (1000mA) 40V LED Driver with Switch Dimming	SOP-8 (Tape & Reel)
ZLED7530-ZI1R	ZLED7530 – High Current (750mA) 40V LED Driver with Switch Dimming	SOP-8 (Tape & Reel)
ZLED7730-ZI1R	ZLED7730 – High Current (350mA) 40V LED Driver with Switch Dimming	SOP-8 (Tape & Reel)
ZLED7030KIT-D1	ZLED7030-D1 Demo Board, 1 ZLED-PCB8 and 5 ZLED7030 ICs	Kit
ZLED-PCB8	Test PCB with one 5W white High Brightness (HB) LED, cascadable to one multiple LED string	Printed Circuit Board (PCB)

Sales and Further Information		www.zmdi.com	LED_Drivers@zmdi.com
Zentrum Mikroelektronik Dresden AG (ZMD AG) Grenzstrasse 28 01109 Dresden Germany Phone +49 (0)351.8822.7.533 Fax +49 (0)351.8822.8.7533	ZMD America, Inc. 8413 Excelsior Drive Suite 200 Madison, WI 53717 USA Phone +1 (608) 829-1987 Fax +1 (631) 549-2882	Zentrum Mikroelektronik Dresden AG, Japan Office 2nd Floor, Shinbashi Tokyu Bldg. 4-21-3, Shinbashi, Minato-ku Tokyo, 105-0004 Japan Phone +81.3.6895.7410 Fax +81.3.6895.7301	ZMD FAR EAST, Ltd. 3F, No. 51, Sec. 2, Keelung Road 11052 Taipei Taiwan Phone +886.2.2377.8189 Fax +886.2.2377.8199
<small>DISCLAIMER: This information applies to a product under development. Its characteristics and specifications are subject to change without notice. Zentrum Mikroelektronik Dresden AG (ZMD AG) assumes no obligation regarding future manufacture unless otherwise agreed to in writing. The information furnished hereby is believed to be true and accurate. However, under no circumstances shall ZMD AG be liable to any customer, licensee, or any other third party for any special, indirect, incidental, or consequential damages of any kind or nature whatsoever arising out of or in any way related to the furnishing, performance, or use of this technical data. ZMD AG hereby expressly disclaims any liability of ZMD AG to any customer, licensee or any other third party, and any such customer, licensee and any other third party hereby waives any liability of ZMD AG for any damages in connection with or arising out of the furnishing, performance or use of this technical data, whether based on contract, warranty, tort (including negligence), strict liability, or otherwise.</small>			

ZLED7030

High Current 40V LED Driver with Switch Dimming



The Analog Mixed Signal Company



Contents

1	IC Characteristics	6
1.1	Absolute Maximum Ratings	6
1.2	Operating Conditions	6
1.3	Electrical Parameters	7
1.4	Typical Operation Graphs	8
2	Circuit Description	13
2.1	ZLED7x30 Overview	13
2.2	Control of Output Current via External Sense Resistor R_s	13
2.3	Multi-Mode Switch Dimming.....	13
2.4	ZLED7x30 Protection Features.....	14
2.4.1	Thermal Shut-down Protection	14
2.4.2	LED Open-Load Protection.....	14
3	Application Circuit Design.....	15
3.1	Applications.....	15
3.2	Thermal Considerations for Application Design	16
3.2.1	Temperature Effects of Load, Layout, and Component Selection.....	16
3.2.2	Temperature Effects of Low Supply Voltage V_{IN}	16
3.3	External Component Selection.....	16
3.3.1	Sense Resistor R_s	16
3.3.2	Inductor L_1	17
3.3.3	Bypass Capacitor C_1	18
3.3.4	De-bouncing Capacitor C_2	20
3.3.5	Capacitor C_3 for Reducing Output Ripple.....	20
3.3.6	Diode D_1	20
3.4	Application Circuit Layout Requirements	20
4	ESD Protection.....	21
5	Pin Configuration and Package	21
6	Ordering Information	22
7	Document Revision History	23

ZLED7030

High Current 40V LED Driver with Switch Dimming



List of Figures

Figure 1.1	ZLED7x30 Supply Operating Current vs. Input Supply Voltage ($V_{IN} = 8.5$ to $40V$)	8
Figure 1.2	Efficiency (%) vs. Input Supply Voltage ($V_{IN} = 8.5$ to $40V$) Per Number of LEDs ($R_S=0.10\Omega$, $L_1=47\mu H$).....	8
Figure 1.3	Efficiency vs. Input Supply Voltage ($V_{IN} = 8.5$ to $40V$) Per Number of LEDs ($R_S=0.15\Omega$, $L_1=47\mu H$)	9
Figure 1.4	Efficiency vs. Input Supply Voltage ($V_{IN} = 8.5$ to $40V$) [†] Per Number of LEDs ($R_S=0.30\Omega$, $L_1=47\mu H$).....	9
Figure 1.5	Output Current Variation vs. Input Supply Voltage ($V_{IN} = 8.5$ to $40V$) Per Number of LEDs ($R_S=0.15\Omega$, $L_1=47\mu H$)	10
Figure 1.6	Sense Voltage vs. Operating Temperature ($R_S=0.10\Omega$, $L_1=47\mu H$, $V_{IN} = 40 V$)	10
Figure 1.7	Switch Dimming Waveform (Dimming Mode 2)	11
Figure 1.8	LED Open-Circuit Protection ($R_S=0.30\Omega$, $L_1=47\mu H$, $V_{IN} = 24 V$)	12
Figure 3.1	ZLED7x30 Application Circuit for Switch Dimming	15
Figure 3.2	Basic ZLED7x30 Application Circuit with Output Current Determined only by R_S	15
Figure 3.3	ZLED7x30 Application Circuit using a Halogen Electronic Transformer to Operate with AC Line Supply	16
Figure 5.1	ZLED7x30 Pin Configuration	21

List of Tables

Table 2.1	Dimming Configuration Options.....	14
Table 3.1	Recommended Values for Sense Resistor R_S	17
Table 5.1	ZLED7x30 Pin Descriptions—SOP-8 Package.....	21
Table 5.2	Package Dimensions SOP-8	22

ZLED7030

High Current 40V LED Driver with Switch Dimming

ZMDI[®]

The Analog Mixed Signal Company



1 IC Characteristics

Note: Exceeding the maximum ratings given in this section could cause operation failure and/or cause permanent damage to the ZLED7x30. Exposure to these conditions for extended periods may affect device reliability.

1.1 Absolute Maximum Ratings

No.	PARAMETER	SYMBOL	CONDITIONS	MIN	TYP	MAX	UNIT
1.1.1	Input voltage (also see specification 1.2.2)	V_{IN}		-0.3		50	V
1.1.2	I _{SENSE} pin voltage	V_{ISENSE}	$V_{IN} \geq 5V$	$V_{IN} - 5V$		$V_{IN} + 0.3V$	V
			$V_{IN} < 5V$	-0.3V		$V_{IN} + 0.3V$	V
1.1.3	LX pin output voltage	V_{LX}		-0.3		50	V
1.1.4	DIM1, DIM2 pin input voltage	V_{DIM}		-0.3		6	V
1.1.5	LX pin switch output current	I_{LX}				1.5	A
1.1.6	Power dissipation	P_{tot}				0.5	W
1.1.7	ESD performance		Human Body Model	± 3			kV
1.1.8	Junction temperature	T_J				150	°C
1.1.9	Junction to ambient thermal resistance	$R_{\theta JA}$				100	K/W
1.1.10	Storage temperature	T_S		-55		150	°C

1.2 Operating Conditions

No.	PARAMETER	SYMBOL	CONDITIONS	MIN	TYP	MAX	UNIT
1.2.1	Operating temperature	T_{amb}		-40		105	°C
1.2.2	Input voltage (also see specification 1.1.1)	V_{IN}		8.5		40	V

ZLED7030

High Current 40V LED Driver with Switch Dimming

ZMDI[®]

The Analog Mixed Signal Company



1.3 Electrical Parameters

Except as noted, test conditions for the following specifications are $T_{amb} = 25^{\circ}\text{C}$ typical and $V_{IN} = 12\text{V}$ unless otherwise noted.

Production testing of the chip is performed at 25°C unless otherwise stated. Functional operation of the chip and specified parameters at other temperatures are guaranteed by design, characterization, and process control.

No.	PARAMETER	SYMBOL	CONDITIONS	MIN	TYP	MAX	UNIT	
1.3.1	Quiescent supply current	I_{INQoff}	Output off	70	120	140	μA	
		I_{INQon}	Output switching		450	600	μA	
1.3.2	Mean current sense threshold voltage	V_{SENSE}		95	100	105	mV	
1.3.3	Sense threshold hysteresis	$V_{SENSEHYS}$			± 15		%	
1.3.4	I_{SENSE} pin input current	I_{SENSE}	$V_{SENSE} = V_{IN} - 0.1\text{V}$		8		μA	
1.3.5	Under-voltage lockout threshold	V_{UVLO}	V_{IN} rising	5.05	5.85	6.65	V	
1.3.6	Under-voltage lockout hysteresis	ΔV_{UVLO}			1.65		V	
1.3.7	Ratio of output current level to initial current in Dimming Mode 1	K_1	DIM1: Floating DIM2: GND	Level 1		100		%
				Level 2		50		%
				Level 3	17	20	23	%
1.3.8	Ratio of output current level to initial current in Dimming Mode 2	K_2	DIM1: GND DIM2: Floating	Level 1		100		%
				Level 2		60		%
				Level 3	28	30	32	%
1.3.9	Ratio of output current level to initial current in Dimming Mode 3	K_3	DIM1: GND DIM2: GND	Level 1		100		%
				Level 2	28	30	32	%
1.3.10	Interval time between external switch actions	T_S			2		s	
1.3.11	LX switch continuous current	I_{LXmean_0}	ZLED7030			1.2	A	
		I_{LXmean_3}	ZLED7330			1.0	A	
		I_{LXmean_5}	ZLED7530			0.75	A	
		I_{LXmean_7}	ZLED7730			0.35	A	
1.3.12	LX switch leakage current	$I_{LX(leak)}$			1	μA		
1.3.13	LX switch on resistance	R_{LX}			0.3	0.4	Ω	
1.3.14	Minimum switch on time	t_{ONmin}	LX switch on		200		ns	
1.3.15	Minimum switch off time	t_{OFFmin}	LX switch off		200		ns	
1.3.16	Recommended operating frequency maximum	f_{LXmax}				1	MHz	

ZLED7030

High Current 40V LED Driver with Switch Dimming



The Analog Mixed Signal Company



No.	PARAMETER	SYMBOL	CONDITIONS	MIN	TYP	MAX	UNIT
1.3.17	Recommended output switch duty cycle range at f_{LXmax}	D_{LX}		0.3		0.9	
1.3.18	Propagation delay of internal comparator	t_{PD}			25		ns
1.3.19	Thermal shutdown temperature	T_{SD}			150		°C
1.3.20	Thermal shutdown hysteresis	T_{SD-HYS}			20		K

1.4 Typical Operation Graphs

The curves are valid for the typical application circuit and $T_{amb} = 25^{\circ}\text{C}$ unless otherwise noted.

Figure 1.1 ZLED7x30 Supply Operating Current vs. Input Supply Voltage ($V_{IN} = 8.5$ to 40V)

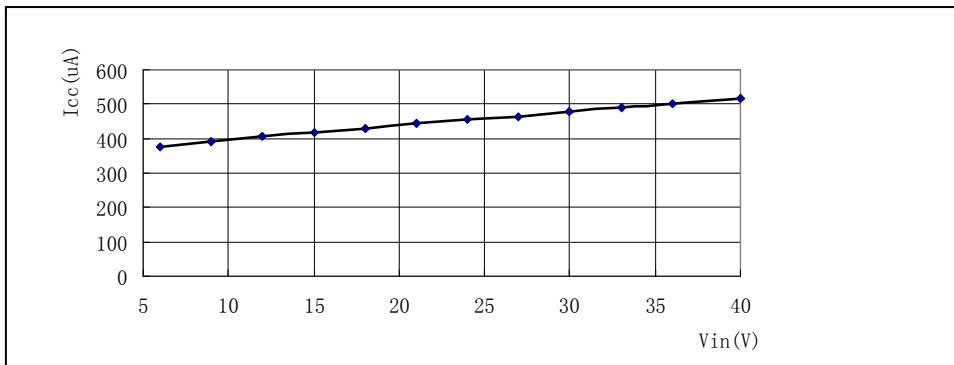
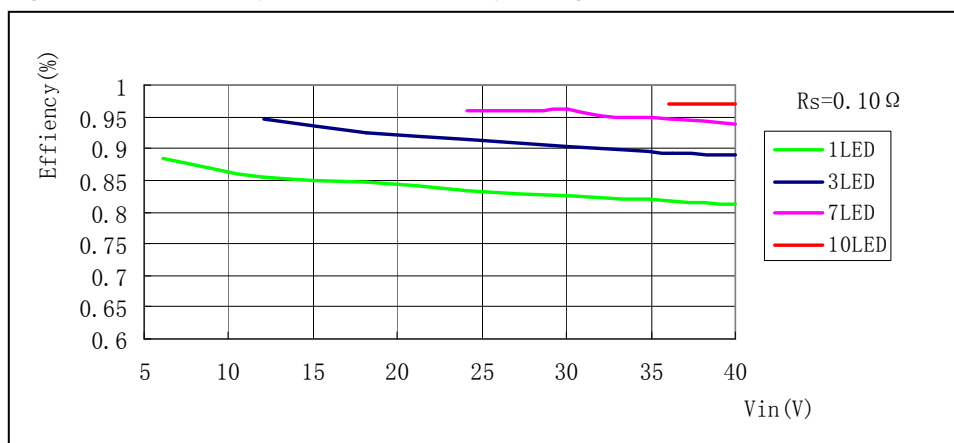

Figure 1.2 Efficiency (%) vs. Input Supply Voltage ($V_{IN} = 8.5$ to 40V)[†] Per Number of LEDs ($R_s=0.10\Omega$, $L_1=47\mu\text{H}$)



[†] Minimum V_{in} depends on number of LEDs.

ZLED7030

High Current 40V LED Driver with Switch Dimming



The Analog Mixed Signal Company



Figure 1.3 Efficiency vs. Input Supply Voltage ($V_{IN} = 8.5$ to $40V$)[‡] Per Number of LEDs ($R_s=0.15\Omega$, $L_1=47\mu H$)

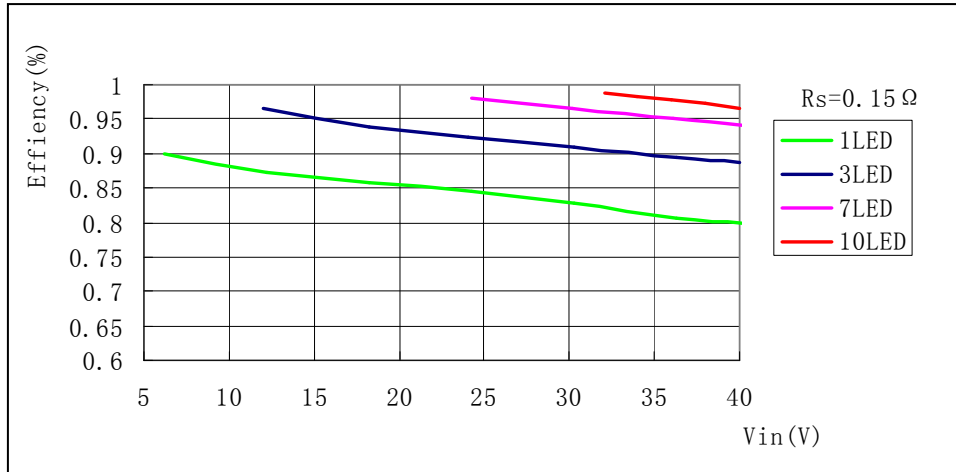
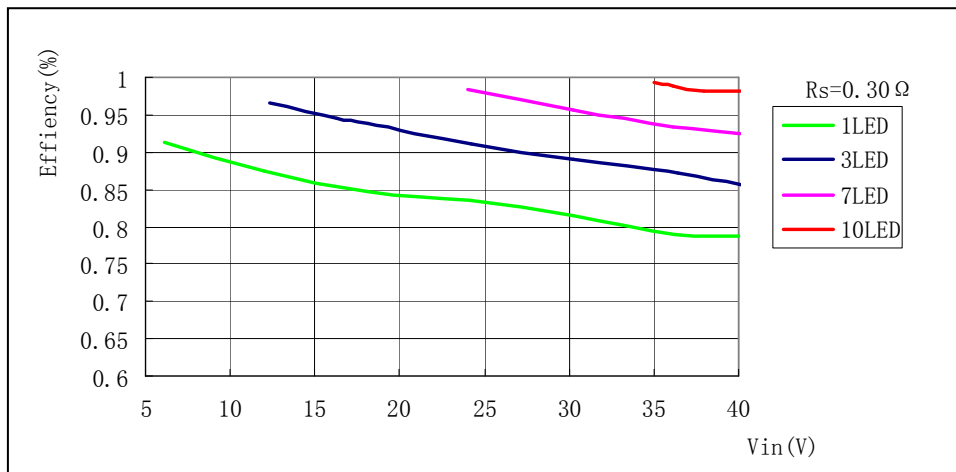

Figure 1.4 Efficiency vs. Input Supply Voltage ($V_{IN} = 8.5$ to $40V$)[‡] Per Number of LEDs ($R_s=0.30\Omega$, $L_1=47\mu H$)



[‡] Minimum V_{in} depends on number of LEDs.

ZLED7030

High Current 40V LED Driver with Switch Dimming



The Analog Mixed Signal Company



Figure 1.5 Output Current Variation vs. Input Supply Voltage ($V_{IN} = 8.5$ to $40V$)[§] Per Number of LEDs ($R_s=0.15\Omega$, $L_1=47\mu H$)

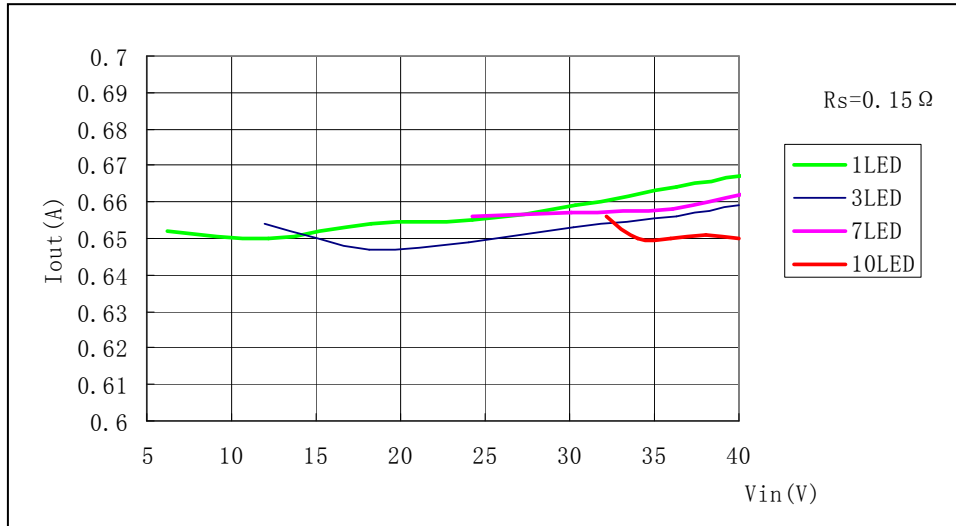
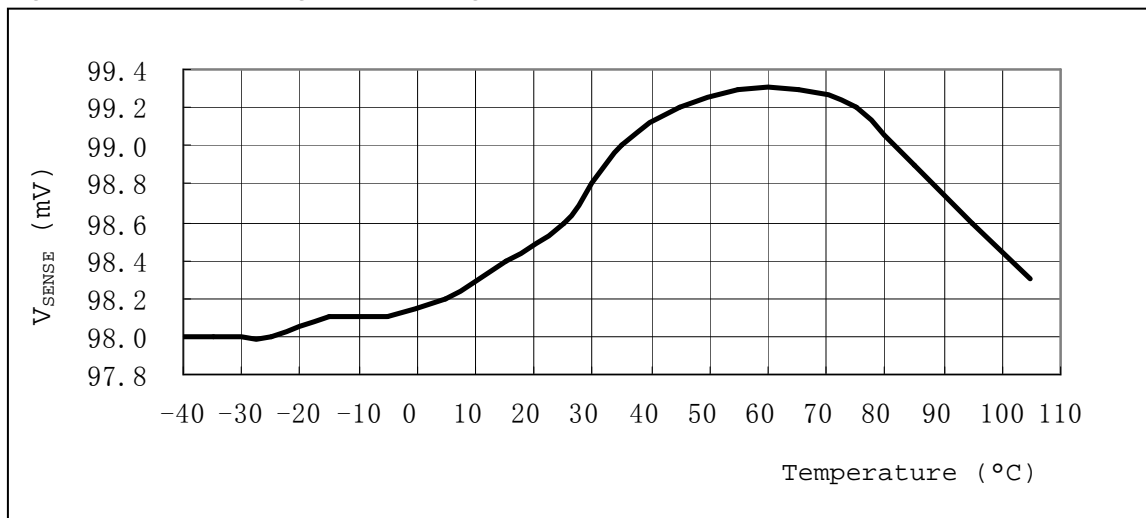

Figure 1.6 Sense Voltage vs. Operating Temperature ($R_s=0.10\Omega$, $L_1=47\mu H$, $V_{IN} = 40 V$)



§ Minimum V_{in} depends on number of LEDs.

ZLED7030

High Current 40V LED Driver with Switch Dimming



The Analog Mixed Signal Company



Figure 1.7 demonstrates a typical switch dimming waveform. Channel 1 (blue) is the supply voltage. Channel 4 (magenta) shows the output current at 100%, then 60%, and then 30%.

Figure 1.7 Switch Dimming Waveform (Dimming Mode 2)

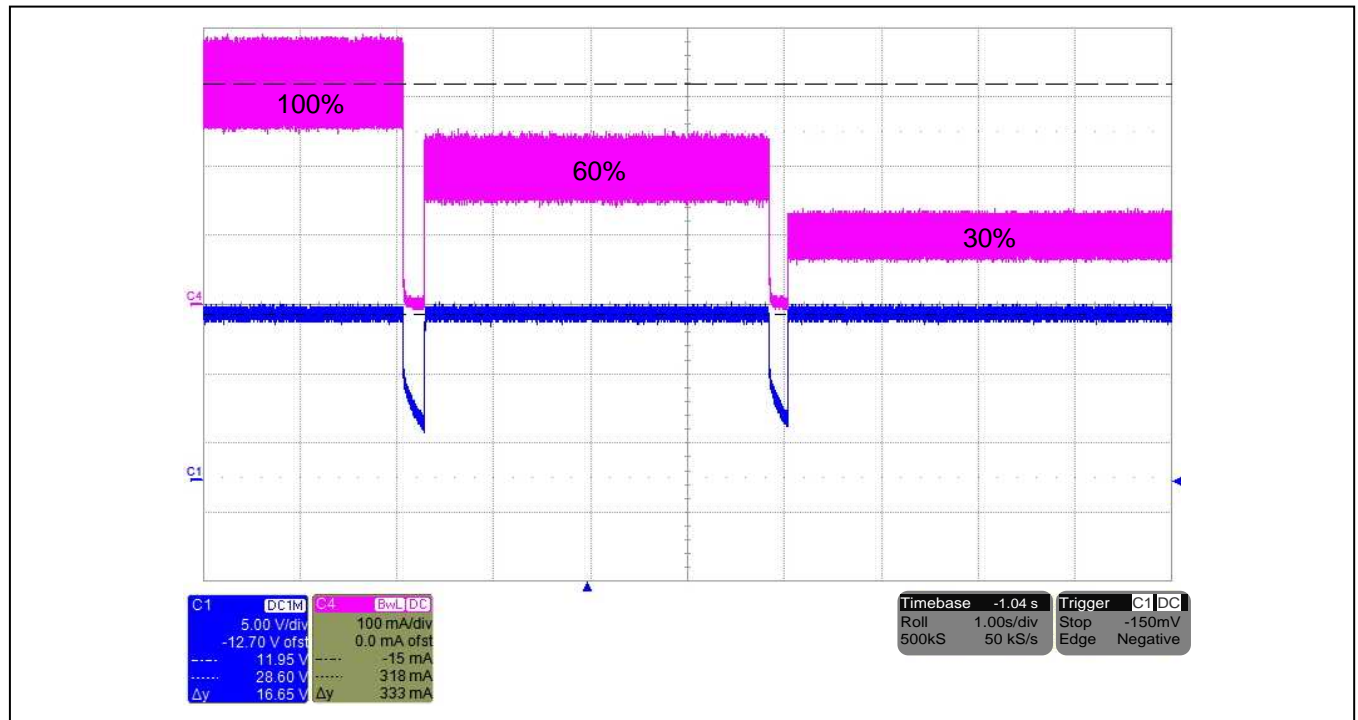

ZLED7030

High Current 40V LED Driver with Switch Dimming



The Analog Mixed Signal Company



Figure 1.8 LED Open-Circuit Protection ($R_s=0.30\Omega$, $L_1=47\mu\text{H}$, $V_{IN} = 24\text{ V}$)

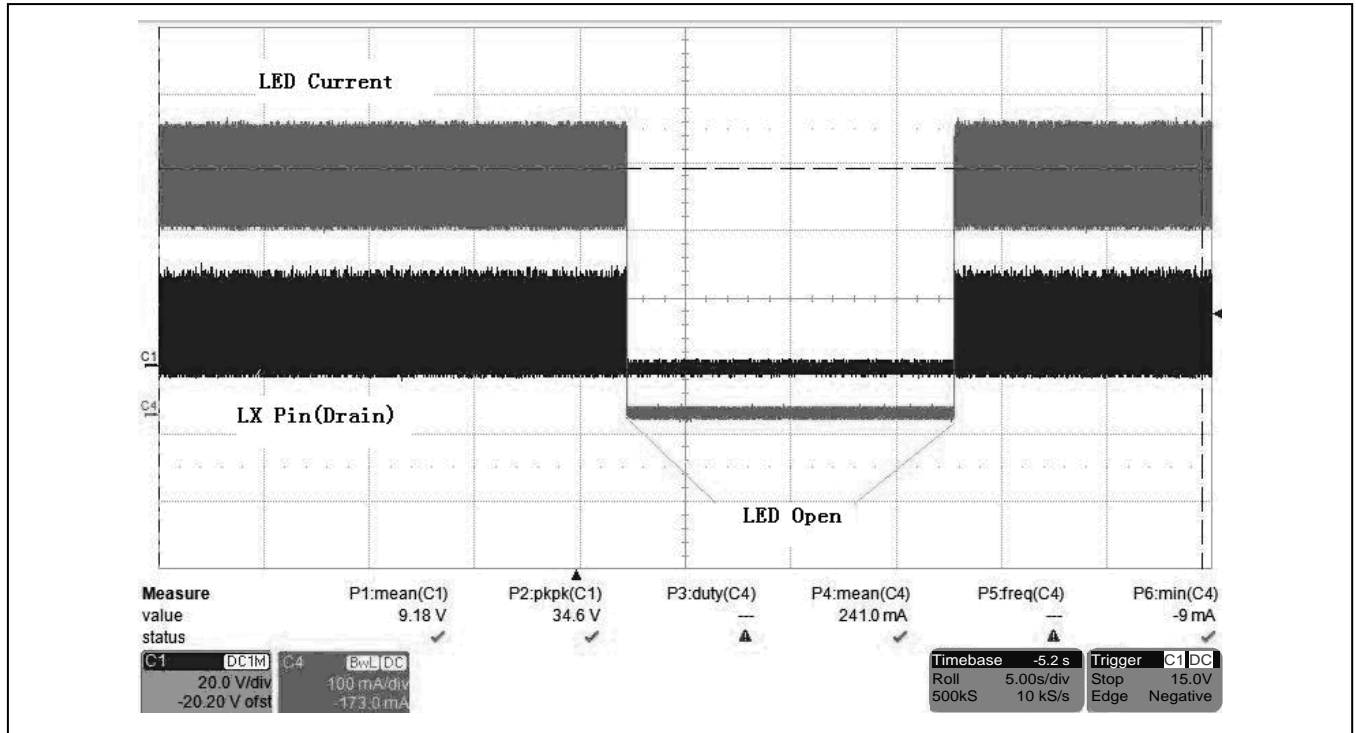



2 Circuit Description

2.1 ZLED7x30 Overview

The ZLED7x30 is a continuous-mode inductive step-down converter LED driver for driving single or multiple series-connected LEDs from a voltage input higher than the LED voltage ($V_{in} = 8.5$ to 40VDC; see section 3.2.2 for important details). The ZLED7x30 provides an adjustable output current (1.2A maximum for ZLED7030; 1.0A maximum for ZLED7330; 0.75A maximum for ZLED7530; 0.35A maximum for ZLED7730), which is nominally set via an external sense resistor R_s and controlled by the ZLED7x30's integrated high-side output current-sensing circuit and output switch. The ZLED7x30 detects external switching action on the supply line to adjust the output current in different modes on different levels.

Only a resistor, a diode, an inductor, and three capacitors are needed for a typical basic application. Refer to the application circuits in section 3 for the location of the components referred to in the following sections.

2.2 Control of Output Current via External Sense Resistor R_s

External sense resistor R_s , which is connected between the V_{IN} and I_{SENSE} pins as shown in Figure 3.1, sets I_{OUTnom} , the nominal average output current. Equation (1) can be used to calculate the nominal output current, which is the LX switch output current I_{LX} if no switch dimming condition is valid. See section 3.3.1 for recommended values for R_s in a typical basic application and section 3.4 for layout guidelines for R_s .

$$I_{OUTnom} = \frac{0.4V}{R_s} \quad (1)$$

2.3 Multi-Mode Switch Dimming

The ZLED7x30 detects external switching action on the supply line to adjust output current, allowing dimming functionality to be achieved without changing the original lighting system circuitry. The switch dimming is implemented in either two-level mode or three-level mode. The output current of each level and the total number of levels are customer selected by setting the corresponding input conditions on the DIM1 and DIM2 pins. See page 2 for a typical application using the DIM1 and DIM2 pins.

The output current is set at the initial 100% value determined by the sense resistor R_s the first time that power is supplied to the chip. After the initial power up sequence, the chip adjusts the output current according to the external switch action. After the lowest current level, the current cycles back to the initial value if subsequent switch action is detected. If the power is switched off for longer than 2 seconds, the device will return to its initial state and the output current will be set to the initial value the next time that power is applied.

There are two types of switch action: a normal switch, which has an off-time between each subsequent switch action longer than 2s, and a dimming switch, which has an off-time between each subsequent switch less than 2s.

The dimmed average output current is given by

$$I_{OUTdim} = K_X * \frac{0.4V}{R_s} \quad (2)$$

Where

ZLED7030

High Current 40V LED Driver with Switch Dimming

ZMDI[®]

The Analog Mixed Signal Company



K_x = Current ratio to initial current (see section 1.3).

The input conditions on the DIM1 and DIM2 pins set the number of current levels and the current ratio relative to the initial average current for the dimming switch (DS) sequences as shown in Table 2.1.

Table 2.1 Dimming Configuration Options

Dimming Mode	DIM1	DIM2	Dimming Ratio K
No dimming	Floating	Floating	(100%)
1	Floating	GND	100% → 1 st DS → 50% → 2 nd DS → 20% → 3 rd DS → 100% ...
2	GND	Floating	100% → 1 st DS → 60% → 2 nd DS → 30% → 3 rd DS → 100% ...
3	GND	GND	100% → 1 st DS → 30% → 2 nd DS → 100% ...

If a normal switch is detected or if DIM1 and DIM2 are both floating, the output current goes back to the initial state of 100% nominal average output current. Since ZLED7x30 needs to count the time for more than 2 seconds after the switch is off during a normal switch, one capacitor (C1) equal to or greater than 220 μ F is required to keep the chip working in low quiescent current mode during this part of the off-time.

2.4 ZLED7x30 Protection Features

2.4.1 Thermal Shut-down Protection

The ZLED7x30 automatically protects itself from damage due to over-temperature conditions. If the ZLED7x30's temperature exceeds the thermal shutdown threshold ($T_{SD} = 150^{\circ}\text{C}$, typical), the ZLED7x30 will shutdown. To avoid erratic ZLED7x30 operation, a 20K hysteresis (T_{SD-HYS}) is applied that prevents it from returning to operation until its temperature falls below the hysteresis threshold ($T_{SD} - T_{SD-HYS}$). Also refer to section 3.2 for additional thermal considerations.

2.4.2 LED Open-Load Protection

As a step-down converter, the ZLED7x30 has inherent open-load circuit protection. Since the L1 inductor is connected in series with the LED string, the current flow is interrupted if the load is open and the LX output of the ZLED7x30 will not be damaged. This provides an advantage over other products such as boost converters, for which the internal switch can be damaged by back EMF forcing the drain above its breakdown voltage.



3 Application Circuit Design

3.1 Applications

The ZLED7x30 is designed for applications requiring features such as high-speed switching, variable brightness control, operation with voltages up to 40V, high efficiency, or protection from over-temperature, or open LED circuit conditions.

Typical applications include MR16/MR11 LED spot lights, LED street lights, parabolic aluminized reflector (PAR) LED lights, and other general purpose industrial and consumer LED applications.

Figure 3.1 shows the minimum configuration for switch dimming applications. Figure 3.2 demonstrates the basic application circuit with the additional capacitors C1 and C3 for enhanced performance. For dimensioning of the current sense resistor, see section 2. An example of operation with a halogen lamp electronic transformer is shown in Figure 3.3.

Figure 3.1 ZLED7x30 Application Circuit for Switch Dimming

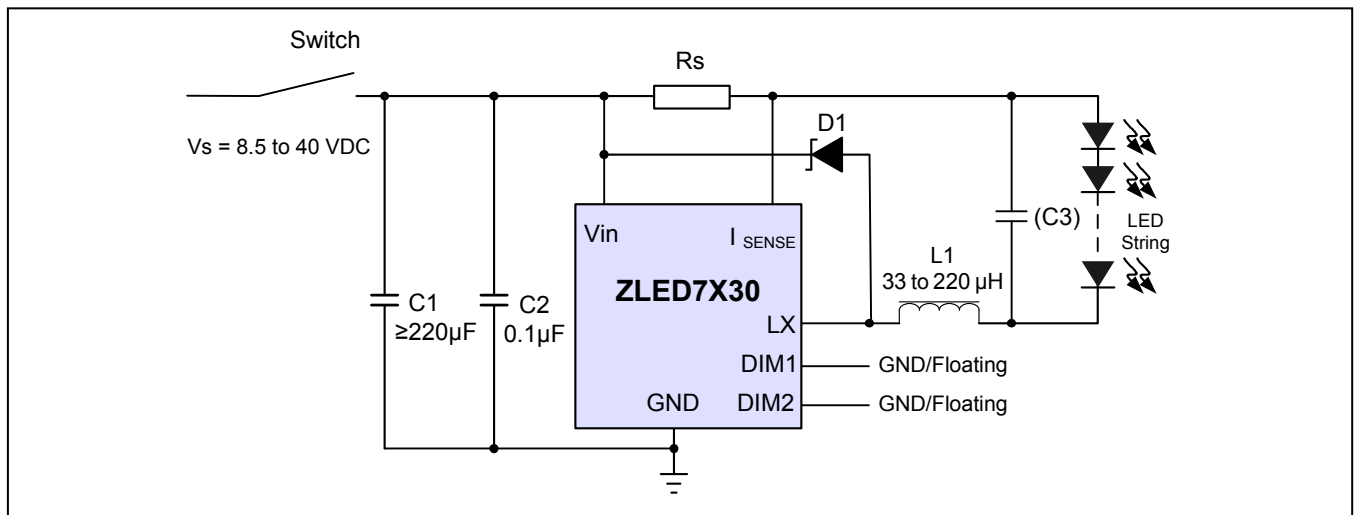
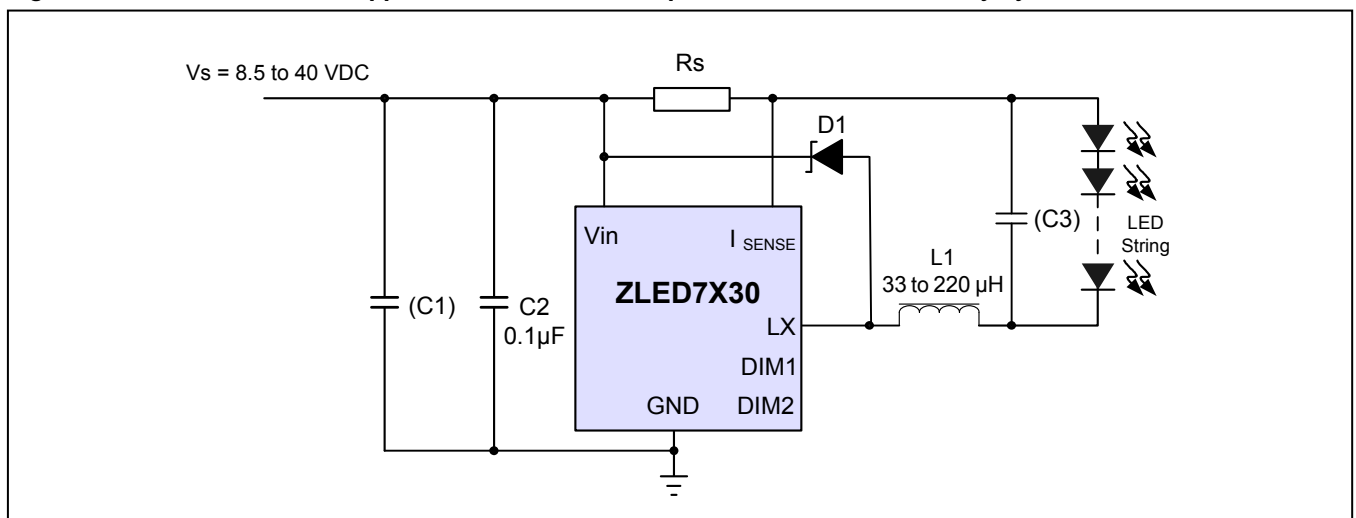

Figure 3.2 Basic ZLED7x30 Application Circuit with Output Current Determined only by Rs



ZLED7030

High Current 40V LED Driver with Switch Dimming

ZMDI[®]

The Analog Mixed Signal Company



Figure 3.3 ZLED7x30 Application Circuit using a Halogen Electronic Transformer to Operate with AC Line Supply

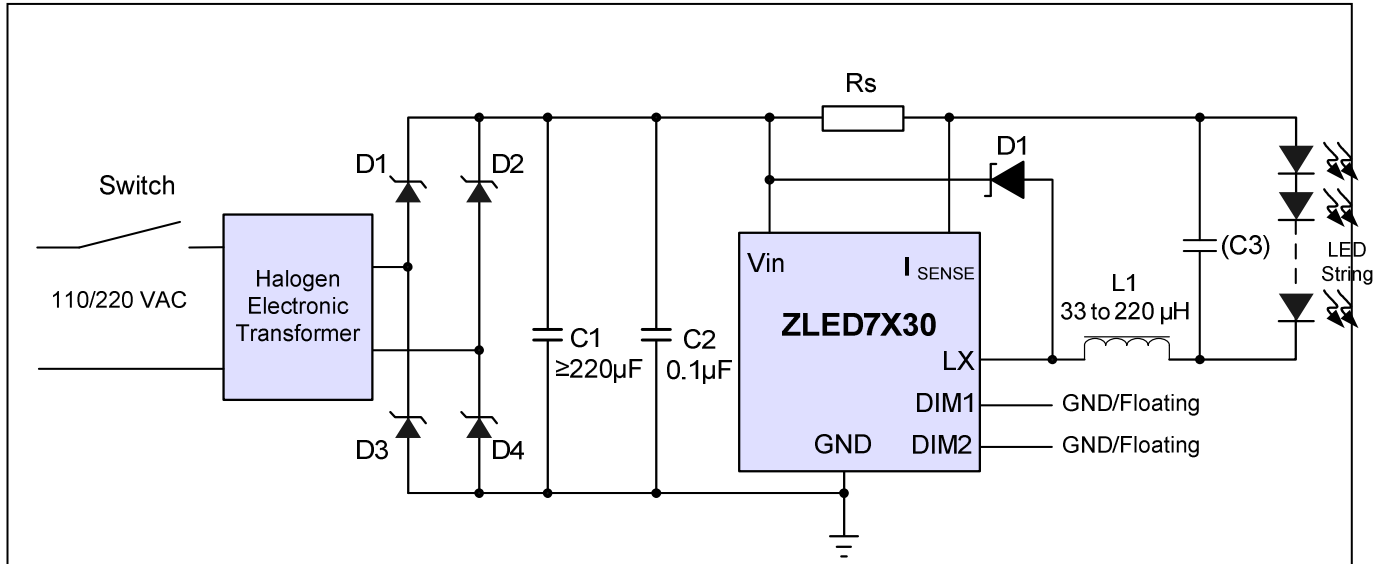

3.2 Thermal Considerations for Application Design

3.2.1 Temperature Effects of Load, Layout, and Component Selection

Do not exceed the package power dissipation limits by driving high load currents or by operating the chip at high ambient temperatures. Power dissipation also increases if the efficiency of the circuit is low as could result from selecting the wrong coil or from excessive parasitic output capacitance on the switch output. See the layout guidelines in section 3.4.

3.2.2 Temperature Effects of Low Supply Voltage V_{IN}

Until the supply input voltage on the V_{IN} pin has risen above the internally-set startup threshold, the ZLED7x30's internal regulator disables the drive to the internal power MOSFET output switch. Above this threshold, the MOSFET on-resistance is low enough for the chip to start to operate; however, if the supply voltage remains below the specified minimum (8.5V), the duty cycle of the output switch will be high and the ZLED7x30 power dissipation will be at a maximum. Avoid operating the ZLED7x30 under such conditions to reduce the risk of damage due to exceeding the maximum die temperature. When driving multiple LEDs, their combined forward voltage drop is typically high enough to prevent the chip from switching when V_{IN} is below 8.5V, so there is less risk of thermal damage.

3.3 External Component Selection

Note: Also see section 3.4 for layout guidelines for the following external components.

3.3.1 Sense Resistor R_s

Table 3.1 gives values for R_s under normal operating conditions in the typical application shown in Figure 3.1. These values assume that no dimming condition is valid. Under the conditions given the table, in order to maintain the switch current below the maximum value specified in section 1, 0.082Ω is the minimum value for R_s for the ZLED7030, 0.1Ω for the ZLED7330, 0.13Ω for the ZLED7530 and 0.27Ω for the ZLED7730.

ZLED7030

High Current 40V LED Driver with Switch Dimming

ZMDI[®]

The Analog Mixed Signal Company



To ensure stable output current, use a 1% accuracy resistor with adequate power tolerance and a good temperature characteristic for R_s .

Table 3.1 Recommended Values for Sense Resistor R_s

Nominal Average Output Current (mA)	Value for R_s (Ω)
1200 (maximum for ZLED7030)	0.082
1000 (maximum for ZLED7330)	0.1
750 (maximum for ZLED7530)	0.13
667	0.15
350 (maximum for ZLED7730)	0.27
333	0.3

3.3.2 Inductor L1

The recommended range for the L1 inductor is 33 μ H to 220 μ H. Select the inductor value for L1 as needed to ensure that switch on/off times are optimized across the load current and supply voltage ranges. If the application requires a high supply voltage and low output current, inductance values at the high end of this range are recommended to minimize errors due to switching delays, which can reduce efficiency and increase ripple on the output. Also see section 3.4 for layout considerations for L1. Equations (3) and (4) can be used to calculate t_{ON} and t_{OFF} .

On Time for LX Switch ($t_{ONmin}>200ns$):

$$t_{ON} = \frac{L * \Delta I}{V_{IN} - V_{LED} - I_{AVG} * (R_s + r_L + R_{LX})} \quad (3)$$

Off Time for LX Switch ($t_{OFFmin}>200ns$):

$$t_{OFF} = \frac{L * \Delta I}{V_{LED} + V_D + I_{AVG} * (R_s + r_L)} \quad (4)$$

Where:

Symbol	Description
L	L1 coil inductance in H
ΔI	L1 coil peak-peak ripple current in A (internally set to $0.3 * I_{AVG}$)
V_{IN}	Supply voltage in V
V_{LED}	Total forward voltage in V for LED string
I_{AVG}	Nominal average LED current in A
R_s	External current sense resistor in Ω
r_L	L1 coil resistance in Ω
R_{LX}	LX switch resistance in Ω
V_D	D1 diode forward voltage at the required load current in V

ZLED7030

High Current 40V LED Driver with Switch Dimming

ZMDI[®]

The Analog Mixed Signal Company



The inductance value has an equivalent effect on t_{ON} and t_{OFF} and therefore affects the switching frequency. For the same reason, the inductance has no influence on the duty cycle, for which the relationship of the summed LED forward voltages $n * V_F$ to the input voltage V_{IN} is a reasonable approximation. Because the input voltage is a factor in the ON time, variations in the input voltage affect the switching frequency and duty cycle.

To achieve optimum performance, duty cycles close to 0.5 at the nominal average supply voltage are preferable for improving the temperature stability of the output current.

Equations (5), (6), (7), and (8) provide an example of calculating t_{ON} , t_{OFF} , operating frequency f_{LX} , and duty cycle D_{LX} when using a 220 μ H inductor for L1 and $V_{IN}=12V$, $R_s = 0.30\Omega$, $r_L=0.26\Omega$, $V_{LED}=3.4V$, $I_{AVG} = 333mA$, $V_D=0.36V$, and $R_{LX}=0.27\Omega$.

Example:

$$t_{ON} = \frac{220\mu H * 0.3 * 0.333A}{12V - 3.4V - 0.333A * (0.30\Omega + 0.26\Omega + 0.27\Omega)} = 2.64\mu s \quad (5)$$

$$t_{OFF} = \frac{220\mu H * 0.3 * 0.333A}{3.4V + 0.36V + 0.333A * (0.30\Omega + 0.26\Omega)} = 5.56\mu s \quad (6)$$

$$f_{LX} = \frac{1}{T_{ON} + T_{OFF}} = \frac{1}{2.64\mu s + 5.56\mu s} = 121.8kHz \quad (7)$$

$$D_{LX} = \frac{V_{LED}}{V_{IN}} = \frac{3.4V}{12V} \approx \frac{T_{ON}}{T_{ON} + T_{OFF}} = \frac{2.64\mu s}{2.64\mu s + 5.56\mu s} \approx 0.3 \quad (8)$$

For the L1 inductor, use a coil with a continuous current rating higher than the required mean output current and a saturation current that exceeds the peak output current by 30% to 50% for robustness against transient conditions; e.g., during start-up.

3.3.3 Bypass Capacitor C1

The bypass capacitor C1 has two functions: maintaining operating voltage and bypassing the current ripple of the switching converter. In general, low ESR capacitors must be used.

If the circuit is supplied by rectified line voltage, C1 must provide enough charge to maintain the ZLED7x30's minimum operating voltage as well as the forward voltage of the LED string to keep the application working even if the rectified supply voltage periodically drops below these values. A rough estimate for the minimum capacity needed can be calculated with equation (9).

ZLED7030

High Current 40V LED Driver with Switch Dimming

ZMDI[®]

The Analog Mixed Signal Company



$$C1_{MIN} = \frac{I_{AVG} * t_D}{\Delta V_{MAX}} = \frac{I_F * D_{LX}}{\Delta V_{MAX} * f_{LX}} \quad (9)$$

Where:

Symbol	Description
I_{AVG}	Average nominal LED string current assuming that the contribution of the IC supply current is negligible.
t_D	Discharge time at given AC frequency. Will be a maximum of 10ms (½ period duration) at 50Hz.
ΔV_{MAX}	Peak rectified supply voltage minus LED string forward voltage or minimum ZLED7x30 supply voltage, whichever is greater.

Example: For an application with 3 LEDs with 3.2V forward voltage each driven at 0.33A and supplied with rectified 24VAC, a minimum bypass capacitor C1 of 220µF or 330µF might be adequate. Compared to the calculation, a safety margin of about 50% must be added to consider temperature effects and aging.

$$C1_{MIN} = \frac{0.33A * 10ms}{24V * \sqrt{2} - 3 * 3.2V} = 135\mu F \quad (10)$$

A second function of C1 is to bypass the current ripple of the switching converter and thus prevent it from disturbing a stable IC supply or backlash on the power supply circuit. For this reason even in DC-supplied applications, the use of an adequate C1 might be useful. The defining parameters are now as shown in equation (11):

$$C1_{MIN} = \frac{I_{AVG} * t_{ON}}{V_{ripple}} \quad (11)$$

Where:

Symbol	Description
I_{AVG}	Average nominal LED string current.
t_{ON}	ON time of the internal MOSFET output switch. Note: t_{ON} must be longer than $t_{ONmin}=200ns$.
V_{ripple}	Permissible voltage ripple on the supply voltage.

ZLED7030

High Current 40V LED Driver with Switch Dimming

ZMDI[®]

The Analog Mixed Signal Company



Example: For an application of 3 LEDs driven at 0.33A and supplied with 24VDC, a maximum ripple of 10% is allowed. The ZLED7x30 is operated at 150kHz with a duty cycle of 0.4 leading to an ON time of 2.67 μ s. As calculated in equation 12, a capacitor C1 of 470nF may be adequate, again including a safety margin of about 50%.

$$C1_{MIN} = \frac{0.33A * 2.67 \mu s}{24V * 0.1} = 367nF \quad (12)$$

To achieve maximum stability over temperature and voltage, an X7R, X5R, or better dielectric is recommended while Y5V must be avoided.

3.3.4 De-bouncing Capacitor C2

External capacitor C2 minimizes ground bounce during switching of the internal MOSFET output switch. Ground bounce is typically caused by parasitic inductance and resistance due to the distance between the grounds for the power supply and the ZLED7x30 GND pin. Use a 0.1 μ F, X7R ceramic capacitor to ground for C2.

3.3.5 Capacitor C3 for Reducing Output Ripple

If required, the C3 can be used to reduce peak-to-peak ripple current in the LED string. Low ESR capacitors should be used because the efficiency of C3 largely depends on its ESR and the dynamic resistance of the LEDs. For an increased number of LEDs, using the same capacitor will be more effective. Lower ripple can be achieved with higher capacitor values, but this will increase start-up delay by reducing the slope of the LED voltage as well as cause increased current during converter start-up. The capacitor will not affect operating frequency or efficiency. For a simulation or bench optimization, C3 values of a few μ F are an applicable starting point for the given configuration. Ripple current reduction is approximately proportional to the value of C3.

3.3.6 Diode D1

The flyback diode D1 must have a continuous current rating greater than the maximum output load current and a peak current rating higher than the peak L1 coil current. Important: Use a low-capacitance, fast Schottky diode that has low reverse leakage at the maximum operating temperature and maximum operating voltage for the application to avoid excess power dissipation and optimize performance and efficiency. For silicon diodes, there is a concern that the higher forward voltage and increased overshoot from reverse recovery time could increase the peak LX pin voltage (V_{LX}). The total voltage V_{LX} (including ripple voltage) must not be >50V.

3.4 Application Circuit Layout Requirements

The following guidelines are strongly recommended when laying out application circuits:

- Important: Locate the L1 inductor and the C1 input decoupling capacitor as close as possible to the ZLED7x30 to minimize parasitic inductance and resistance, which can compromise efficiency. Use low resistance connections from L1 to the LX and V_{IN} pins.
- All circuit board traces to the LX pin must be as short as possible because it is a high-speed switching node.
- To minimize ground bounce, locate the 0.1 μ F external capacitor C2 as close as possible to the V_{IN} pin and solder the ZLED7x30's GND pin directly to the ground plane. (Also, see section 3.3.4 regarding ground bounce.)

ZLED7030

High Current 40V LED Driver with Switch Dimming



- Because R_s is typically a low value resistor, it is important to consider the resistance of the traces in series with R_s as part of the total current sense resistance. Use traces that are as short and wide as possible to minimize this effect.
- The ZLED7x30's DIM pins are high impedance inputs. When left floating, these pins are pulled up to 3.3V by internal circuitry. Avoid running high voltage traces close to the DIM pins.

4 ESD Protection

All pins have an ESD protection of $\geq \pm 3000V$ according to the Human Body Model (HBM). The ESD test follows the Human Body Model with 1.5 k Ω /100 pF based on MIL 883-H, Method 3015.8.

5 Pin Configuration and Package

Figure 5.1 ZLED7x30 Pin Configuration

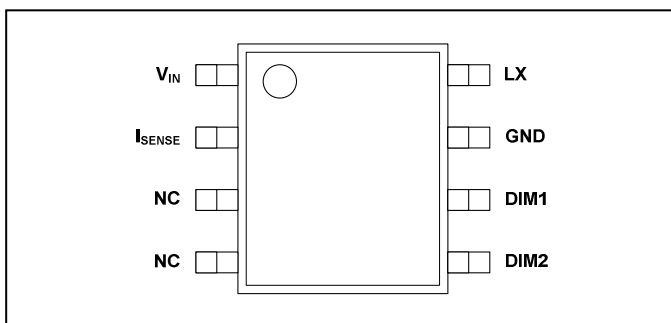

Table 5.1 ZLED7x30 Pin Descriptions—SOP-8 Package

Pin	No.	Description (Also see section 3.3 for layout guidelines)															
V_{IN}	1	Input voltage (8.5V to 40V).															
I_{SENSE}	2	Current adjustment input. Resistor R_s from I_{SENSE} to V_{IN} determines the nominal average output current. $I_{OUTnom} = 0.1V/R_s$															
NC	3	Not connected; keep floating.															
NC	4	Not connected; keep floating.															
DIM2	5	Set the number of current levels and current ratio of each level of switch dimming function as follows: <table border="1" style="margin-left: 20px;"> <thead> <tr> <th>DIM1 Pin</th> <th>DIM2 Pin</th> <th>Dimming Mode</th> </tr> </thead> <tbody> <tr> <td>Floating</td> <td>Floating</td> <td>No dimming</td> </tr> <tr> <td>Floating</td> <td>GND</td> <td>Three levels: 100%, 50%, 20%</td> </tr> <tr> <td>GND</td> <td>Floating</td> <td>Three levels: 100%, 60%, 30%</td> </tr> <tr> <td>GND</td> <td>GND</td> <td>Two levels: 100%, 30%</td> </tr> </tbody> </table>	DIM1 Pin	DIM2 Pin	Dimming Mode	Floating	Floating	No dimming	Floating	GND	Three levels: 100%, 50%, 20%	GND	Floating	Three levels: 100%, 60%, 30%	GND	GND	Two levels: 100%, 30%
DIM1 Pin	DIM2 Pin		Dimming Mode														
Floating	Floating		No dimming														
Floating	GND		Three levels: 100%, 50%, 20%														
GND	Floating	Three levels: 100%, 60%, 30%															
GND	GND	Two levels: 100%, 30%															
DIM1	6																
GND	7	Connect to GND.															
LX	8	Drain of internal power switch															

ZLED7030

High Current 40V LED Driver with Switch Dimming



The Analog Mixed Signal Company



SOP8 Package Dimensions

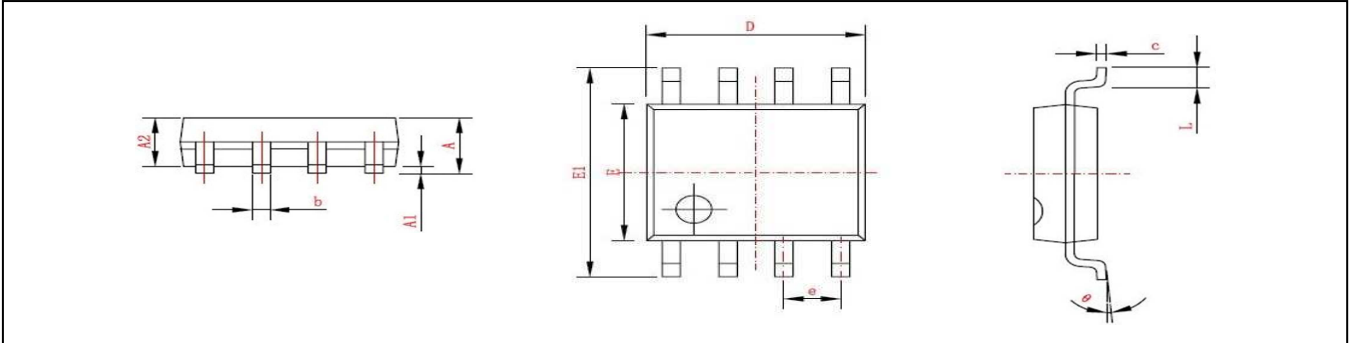

Table 5.2 Package Dimensions SOP-8

Symbol	Dimension (mm)		Symbol	Dimension (mm, except θ)	
	Min	Max		Min	Max
A	1.350	1.750	E	3.800	4.000
A1	0.100	0.250	E1	5.800	6.240
A2	1.450 Typical		e	1.270 Typical	
b	0.350	0.490	L	0.400	1.270
c	0.178	0.250	θ	0°	8°
D	4.800	5.000			

The SOP-8 package has a thermal resistance (junction to ambient) of $R_{\theta JA} = 128 \text{ K/W}$.

6 Ordering Information

Ordering Information

Product Sales Code	Description	Package
ZLED7030-ZI1R	ZLED7030 – High Current (1200mA) 40V LED Driver with Switch Dimming	SOP-8 (Tape & Reel)
ZLED7330-ZI1R	ZLED7330 – High Current (1000mA) 40V LED Driver with Switch Dimming	SOP-8 (Tape & Reel)
ZLED7530-ZI1R	ZLED7330 – High Current (750mA) 40V LED Driver with Switch Dimming	SOP-8 (Tape & Reel)
ZLED7730-ZI1R	ZLED7330 – High Current (350mA) 40V LED Driver with Switch Dimming	SOP-8 (Tape & Reel)
ZLED7030KIT-D1	ZLED7030 Demo Kit 12VAC/VDC, including 1 ZLED-PCB8	Kit
ZLED-PCB8	Test PCB with one 5W white High Brightness (HB) LED, cascadable to one multiple LED string	Printed Circuit Board (PCB)
ZLED-PCB2	10 unpopulated test PCBs for modular LED string with footprints of 9 common HB LED types	Printed Circuit Board (PCB)

ZLED7030

High Current 40V LED Driver with Switch Dimming

ZMDI[®]

The Analog Mixed Signal Company



7 Document Revision History

Revision	Date	Description
1.0	14 th June, 2011	First issue.
1.1	9 th August, 2011	Second issue. Updated Demo Kit description. Updated Typical Application Circuit, Figures 3.1, 3.2 and 3.3.
1.2	16 th August, 2011	Third issue. Updated to include ZLED7530 & ZLED7730. Updated Demo Kit description

Sales and Further Information		www.zmdi.com	LED_Drivers@zmdi.com
Zentrum Mikroelektronik Dresden AG (ZMD AG) Grenzstrasse 28 01109 Dresden Germany Phone +49 (0)351.8822.7.533 Fax +49 (0)351.8822.8.7533	ZMD America, Inc. 8413 Excelsior Drive Suite 200 Madison, WI 53717 USA Phone +1 (608) 829-1987 Fax +1 (631) 549-2882	Zentrum Mikroelektronik Dresden AG, Japan Office 2nd Floor, Shinbashi Tokyu Bldg. 4-21-3, Shinbashi, Minato-ku Tokyo, 105-0004 Japan Phone +81.3.6895.7410 Fax +81.3.6895.7301	ZMD FAR EAST, Ltd. 3F, No. 51, Sec. 2, Keelung Road 11052 Taipei Taiwan Phone +886.2.2377.8189 Fax +886.2.2377.8199
<small>DISCLAIMER: This information applies to a product under development. Its characteristics and specifications are subject to change without notice. Zentrum Mikroelektronik Dresden AG (ZMD AG) assumes no obligation regarding future manufacture unless otherwise agreed to in writing. The information furnished hereby is believed to be true and accurate. However, under no circumstances shall ZMD AG be liable to any customer, licensee, or any other third party for any special, indirect, incidental, or consequential damages of any kind or nature whatsoever arising out of or in any way related to the furnishing, performance, or use of this technical data. ZMD AG hereby expressly disclaims any liability of ZMD AG to any customer, licensee or any other third party, and any such customer, licensee and any other third party hereby waives any liability of ZMD AG for any damages in connection with or arising out of the furnishing, performance or use of this technical data, whether based on contract, warranty, tort (including negligence), strict liability, or otherwise.</small>			

Data Sheet August 16, 2011	© 2011 Zentrum Mikroelektronik Dresden AG — Rev.1.2 All rights reserved. The material contained herein may not be reproduced, adapted, merged, translated, stored, or used without the prior written consent of the copyright owner. The information furnished in this publication is subject to changes without notice.	23 of 23
--------------------------------------	---	----------