

MAXIM

±80V Fault-Protected, 2Mbps, Low Supply Current CAN Transceiver

General Description

The MAX3053 interfaces between the control area network (CAN) protocol controller and the physical wires of the bus lines in a CAN. It is primarily intended for industrial systems requiring data rates up to 2Mbps and features ±80V fault protection against shorts to high-voltage power buses. The device provides differential transmit capability to the bus and differential receive capability to the CAN controller.

The MAX3053 has three different modes of operation: high-speed, slope control, and shutdown. High-speed mode allows data rates up to 2Mbps. In slope control mode, data rates are between 40kbps and 500kbps so the effects of EMI are reduced and unshielded twisted or parallel cable may be used. In shutdown mode, the transmitter is switched off, and the receiver is switched to a low-current mode.

An autosutdown function puts the device in 15µA shutdown mode when the bus or CAN controller is inactive for 47ms or greater.

The MAX3053 is available in an 8-pin SO package and is specified for -40°C to +125°C operation.

Applications

Industrial Control and Networks
Printers
Automotive Systems
HVAC Controls
Telecom 72V Systems

Features

- ◆ ±80V Fault Protection
- ◆ Three Operating Modes
 - High-Speed Operation up to 2Mbps
 - Slope Control Mode to Reduce EMI (40kbps to 500kbps)
- ◆ 15µA Low-Current Shutdown Mode
- ◆ Autosutdown when Device Is Inactive
- ◆ Automatic Wakeup from Shutdown
- ◆ Thermal Shutdown
- ◆ Current Limiting
- ◆ Fully Compatible with the ISO 11898 Standard

Ordering Information

PART	TEMP RANGE	PIN-PACKAGE
MAX3053ESA	-40°C to +85°C	8 SO
MAX3053ASA	-40°C to +125°C	8 SO

Pin Configuration appears at end of data sheet.

Typical Operating Circuit

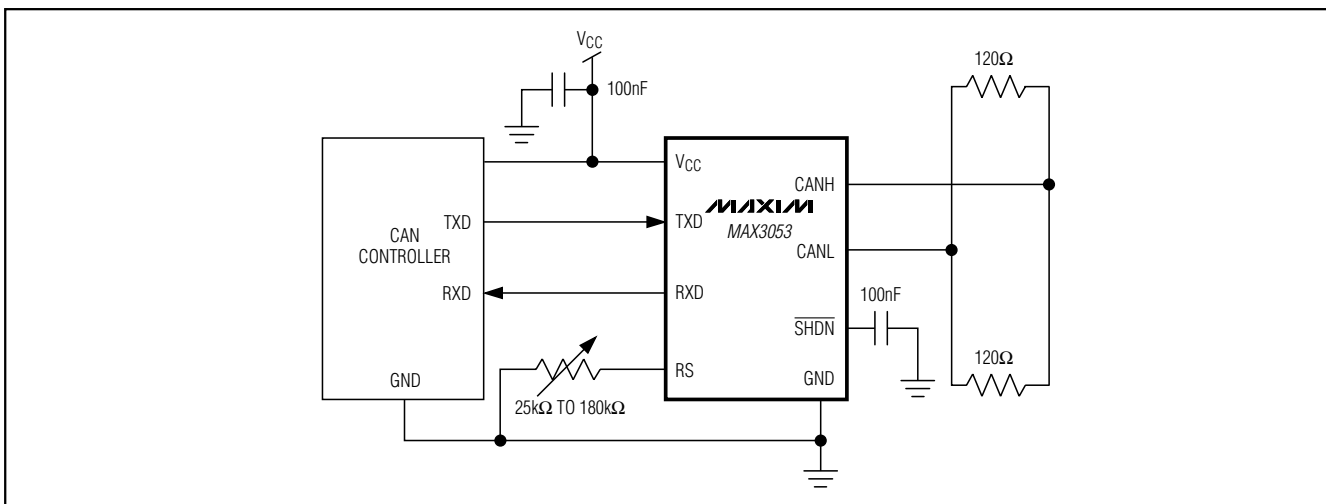
**MAXIM**

Maxim Integrated Products 1

For pricing delivery, and ordering information please contact Maxim/Dallas Direct! at 1-888-629-4642, or visit Maxim's website at www.maxim-ic.com.

MAX3053

±80V Fault-Protected, 2Mbps, Low Supply Current CAN Transceiver

ABSOLUTE MAXIMUM RATINGS

V _{CC} to GND	-0.3V to +6V
TXD, RS, RXD, SHDN to GND	-0.3V to (V _{CC} + 0.3V)
RXD Shorted to GND	Continuous
CANH, CANL to GND	-80V to +80V Continuous
Continuous Power Dissipation	
8-Pin SO (derate 5.9mW/°C above +70°C)	470mW

Operating Temperature Ranges	
MAX3053ASA	-40°C to +125°C
MAX3053ESA	-40°C to +85°C
Junction Temperature	+150°C
Storage Temperature Range	-65°C to +150°C
Lead Temperature (soldering, 10s)	+300°C

Stresses beyond those listed under "Absolute Maximum Ratings" may cause permanent damage to the device. These are stress ratings only, and functional operation of the device at these or any other conditions beyond those indicated in the operational sections of the specifications is not implied. Exposure to absolute maximum rating conditions for extended periods may affect device reliability.

DC ELECTRICAL CHARACTERISTICS

(V_{CC} = +5V ±10%, R_L = 60Ω, R_S = GND, T_A = T_{MIN} to T_{MAX}, unless otherwise noted. Typical values are at V_{CC} = +5V and T_A = +25°C.)

PARAMETER	SYMBOL	CONDITIONS	MIN	TYP	MAX	UNITS
Supply Current	I _S	Dominant (Note 1)		56	72	mA
		Dominant (no load)			6	
		Recessive (Note 1)		3.6	5.5	
		Recessive (no load)			5.5	
Shutdown Supply Current	I _{QSHDN}	SHDN = GND		15	30	μA
Thermal Shutdown Threshold				160		°C
Thermal Shutdown Hysteresis				20		°C
TXD INPUT LEVELS						
High-Level Input Voltage	V _{IH}		2.0			V
Low-Level Input Voltage	V _{IL}				0.4	V
High-Level Input Current	I _{IH}	V _{TXD} = V _{CC}		1		μA
Pullup Resistor	R _{INTXD}			20		kΩ
CANH, CANL TRANSMITTER						
Recessive Bus Voltage	V _{CANH} , V _{CANL}	V _{TXD} = V _{CC} , no load	2		3	V
Off-State Output Leakage	I _{LO}	-2V < V _{CANH} , V _{CANL} < +7V, SHDN = GND, V _{TXD} = V _{CC}	-2		+1	mA
		-80V < V _{CANH} , V _{CANL} < +80V, SHDN = GND, V _{TXD} = V _{CC}	-4		+4	
CANH Output Voltage	V _{CANH}	V _{TXD} = 0	3.0		V _{CC}	V
CANL Output Voltage	V _{CANL}	V _{TXD} = 0	0		2.0	V
Differential Output (V _{CANH} - V _{CANL})	ΔV _{CANH} , V _{CANL}	V _{TXD} = 0	1.5		5	V
		V _{TXD} = 0, R _L = 45Ω	1.5			
		V _{TXD} = V _{CC} ; no load	-500		+50	mV
CANH Short-Circuit Current	I _{SC}	V _{CANH} = -5V	-200			mA
CANL Short-Circuit Current	I _{SC}	V _{CANL} = 18V			200	mA
ESD CANH, CANL (Note 2)		Human Body Model		± 2		kV
		IEC1000-4-2 Air-Gap Discharge		± 3		
		IEC1000-4-2 Contact Discharge		± 2.5		

±80V Fault-Protected, 2Mbps, Low Supply Current CAN Transceiver

MAX3053

DC ELECTRICAL CHARACTERISTICS (continued)

($V_{CC} = +5V \pm 10\%$, $R_L = 60\Omega$, $R_S = GND$, $T_A = T_{MIN}$ to T_{MAX} , unless otherwise noted. Typical values are at $V_{CC} = +5V$ and $T_A = +25^\circ C$.)

PARAMETER	SYMBOL	CONDITIONS	MIN	TYP	MAX	UNITS
DC BUS RECEIVER ($V_{TXD} = V_{CC}$; CANH and CANL externally driven ($-2V < V_{CANH}$, $V_{CANL} < +7V$, unless otherwise specified))						
Differential Input Voltage (Recessive)	V_{DIFF}	$-7V < V_{CANH}$, $V_{CANL} < +12V$	-1.0		+0.5	V
Differential Input Voltage (Dominant)	V_{DIFF}	$-7V < V_{CANH}$, $V_{CANL} < +12V$	0.9		3.3	V
Differential Input Hysteresis	$V_{DIFF(HYST)}$			150		mV
CANH Input Wakeup Voltage Threshold	$V_{CANH(\overline{SHDN})}$	$\overline{SHDN} = GND$, $V_{TXD} = V_{CC}$	6		9	V
RXD High-Level Output Voltage	V_{OH}	$I = -100\mu A$	0.8 x V_{CC}			V
RXD Low-Level Output Voltage	V_{OL}	$I = 10mA$			0.8	V
		$I = 5mA$			0.4	
CANH and CANL Input Resistance	R_I		5		25	$k\Omega$
Differential Input Resistance	R_{DIFF}		10		100	$k\Omega$
SLOPE CONTROL						
Input Voltage for High Speed	V_{SLP}				0.3 x V_{CC}	V
Slope Control Mode Voltage	V_{SLOPE}	$R_{RS} = 24k\Omega$ to $180k\Omega$	0.4 x V_{CC}		0.6 x V_{CC}	V
Slope Control Mode Current	I_{SLOPE}	$R_{RS} = 24k\Omega$ to $180k\Omega$, $V_{CC} = +5.0V$	-10		-200	μA
High-Speed Mode Current	I_{HS}	$V_{RS} = 0$			-500	μA
AUTOSHUTDOWN						
\overline{SHDN} Input Voltage High			2			V
\overline{SHDN} Input Voltage Low					0.5	V

±80V Fault-Protected, 2Mbps, Low Supply Current CAN Transceiver

TIMING CHARACTERISTICS

($V_{CC} = +5V \pm 10\%$, $R_L = 60\Omega$, $C_L = 100pF$, $T_A = T_{MIN}$ to T_{MAX} , unless otherwise noted. Typical values are at $V_{CC} = +5V$ and $T_A = +25^\circ C$.) (Figures 1, 2, and 3)

PARAMETER	SYMBOL	CONDITIONS	MIN	TYP	MAX	UNITS
Minimum Bit Time	t _{BIT}	V _{RS} = 0 (2Mbps)	0.5			μs
		R _{RS} = 24kΩ (500kbps)	2			
		R _{RS} = 100kΩ (125kbps)	8			
		R _{RS} = 180kΩ (62.5kbps)	25			
Delay TXD to Bus Active	t _{ONTXD}	V _{RS} = 0			40	ns
Delay TXD to Bus Inactive	t _{OFFTXD}	V _{RS} = 0			75	ns
Delay TXD to Receiver Active	t _{ONRXD}	V _{RS} = 0 (2Mbps)			120	μs
		R _{RS} = 24kΩ (500kbps)			0.4	
		R _{RS} = 100kΩ (125kbps)			1.6	
		R _{RS} = 180kΩ (62.5kbps)			5.0	
Delay TXD to Receiver Inactive	t _{OFFRXD}	V _{RS} = 0 (2Mbps)			130	μs
		R _{RS} = 24kΩ (500kbps)			0.45	
		R _{RS} = 100kΩ (125kbps)			1.6	
		R _{RS} = 180kΩ (62.5kbps)			5.0	
Differential Output Slew Rate	ISRI	R _{RS} = 24kΩ (500kbps)		14		V/μs
		R _{RS} = 100kΩ (125kbps)		7		
		R _{RS} = 180kΩ (62.5kbps)		1.6		
Time to Wakeup: CANH > 9V	t _{WAKE}	$\overline{SHDN} = GND$, V _{TXD} = V _{CC}			10	μs
Time to Sleep Mode when Bus Is Recessive	t _{SHDN}	$C_{SHDN} = 100nF$	10		47	ms

Note 1: As defined by ISO \overline{SHDN} , bus value is one of two complementary logical values: dominant or recessive. The dominant value represents the logical 1 and the recessive represents the logical 0. During the simultaneous transmission of the dominant and recessive bits, the resulting bus value is dominant. For MAX3053 values, see the truth table in the *Transmitter* and *Receiver* sections.

Note 2: The ESD structures do not short out CANH and CANL under an ESD event while $-7V < CANH$, $CANL < +12V$.

±80V Fault-Protected, 2Mbps, Low Supply Current CAN Transceiver

Typical Operating Characteristics

($V_{CC} = +5V$, $R_L = 60\Omega$, $C_L = 100pF$, $T_A = +25^\circ C$, unless otherwise specified.)

MAX3053

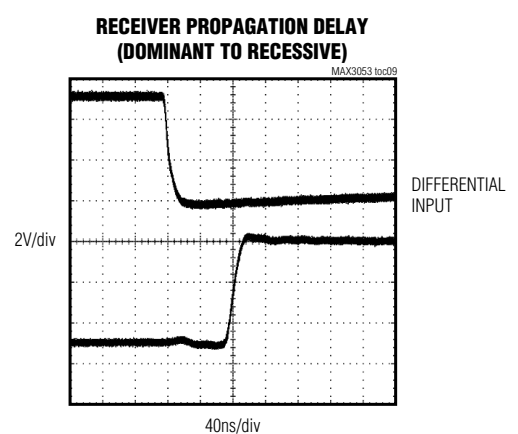
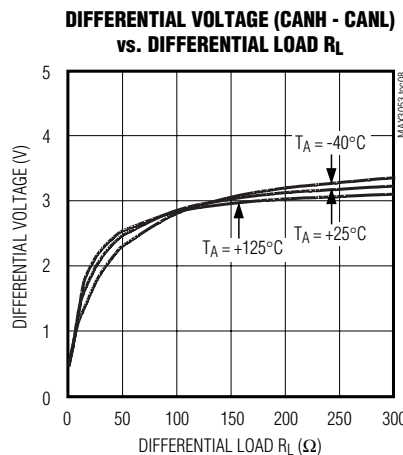
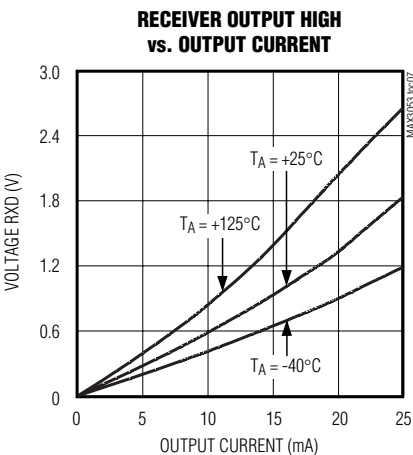
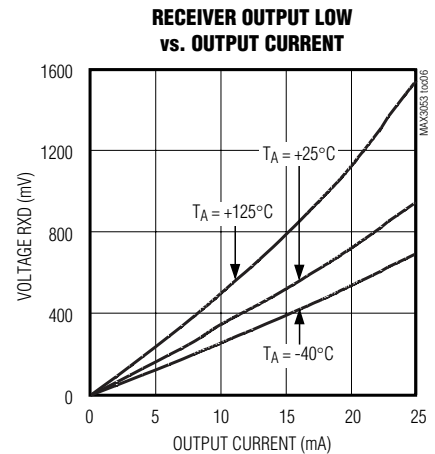
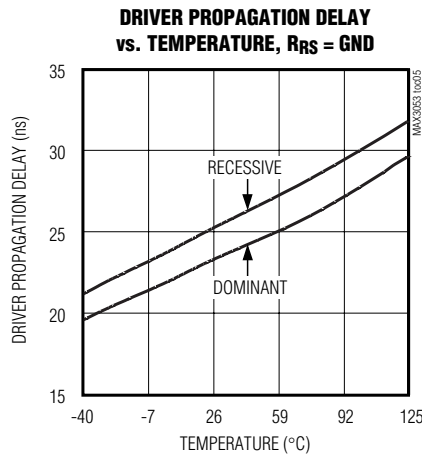
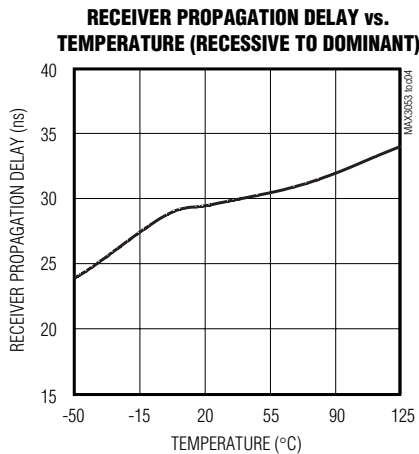
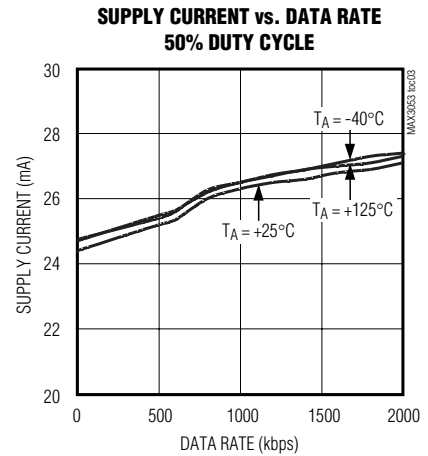
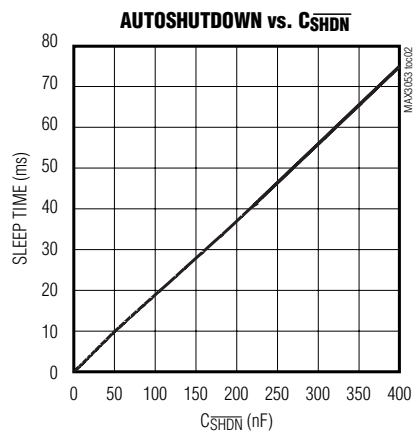
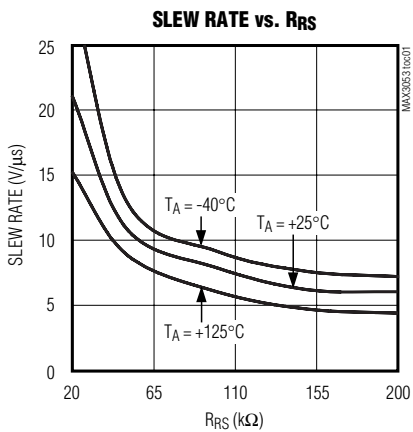

±80V Fault-Protected, 2Mbps, Low Supply Current CAN Transceiver

Typical Operating Characteristics (continued)

($V_{CC} = +5V$, $R_L = 60\Omega$, $C_L = 100pF$, $T_A = +25^\circ C$, unless otherwise specified.)

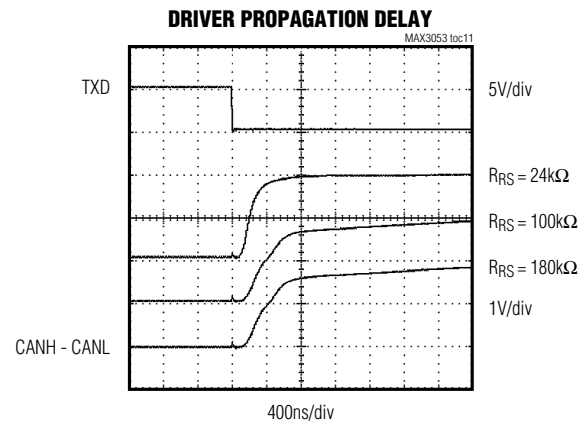
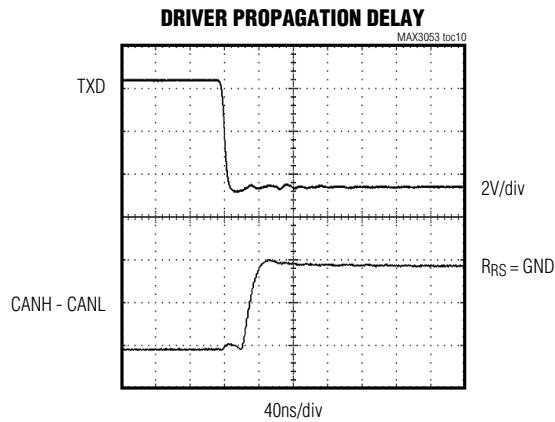

Pin Description

PIN	NAME	FUNCTION
1	TXD	Transmit Data Input. TXD is a CMOS/TTL-compatible input from a CAN controller.
2	GND	Ground
3	V_{CC}	Supply Voltage. Bypass V_{CC} to GND with a 0.1 μF capacitor.
4	RXD	Receive Data Output. RXD is a CMOS/TTL-compatible output from the physical bus lines CANH and CANL.
5	\overline{SHDN}	Shutdown Input. Drive \overline{SHDN} low to put the MAX3053 in shutdown mode. See the <i>Detailed Description</i> section for a full explanation of \overline{SHDN} behavior.
6	CANL	CAN Bus Line LOW. CANL is fault protected to $\pm 80V$.
7	CANH	CAN Bus Line HIGH. CANH is fault protected to $\pm 80V$.
8	RS	Mode Select Pin. Drive RS low or connect to GND for high-speed operation. Connect a resistor from RS to GND to control output slope. See the <i>Mode Selection</i> section.

±80V Fault-Protected, 2Mbps, Low Supply Current CAN Transceiver

Test Circuits/Timing Diagrams

MAX3053

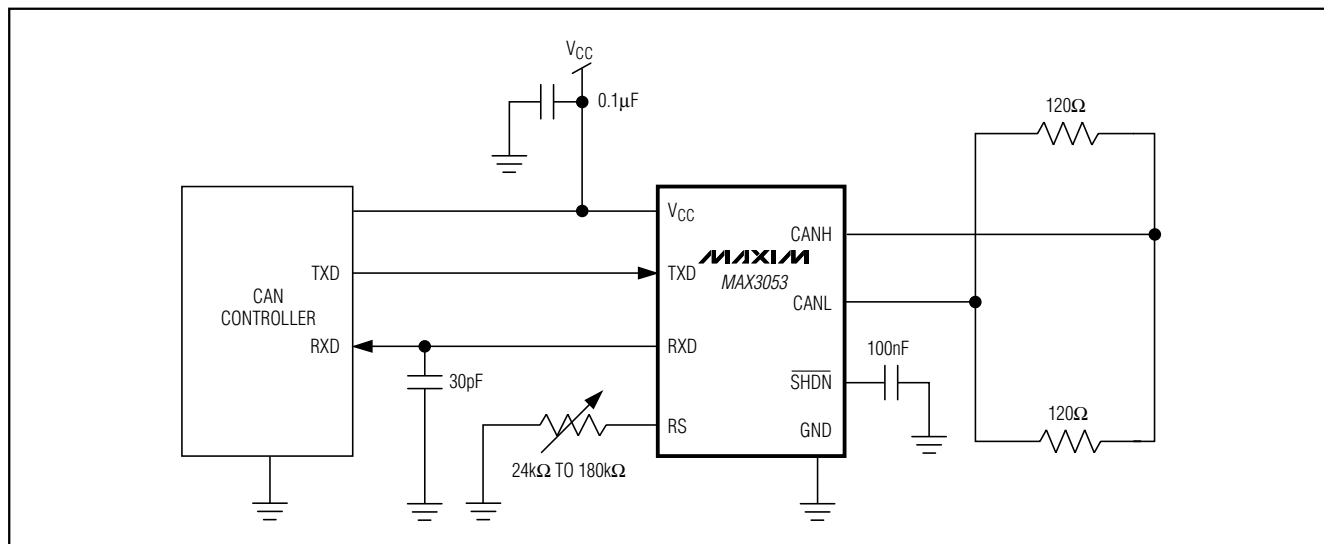

Figure 1. AC Test Circuit

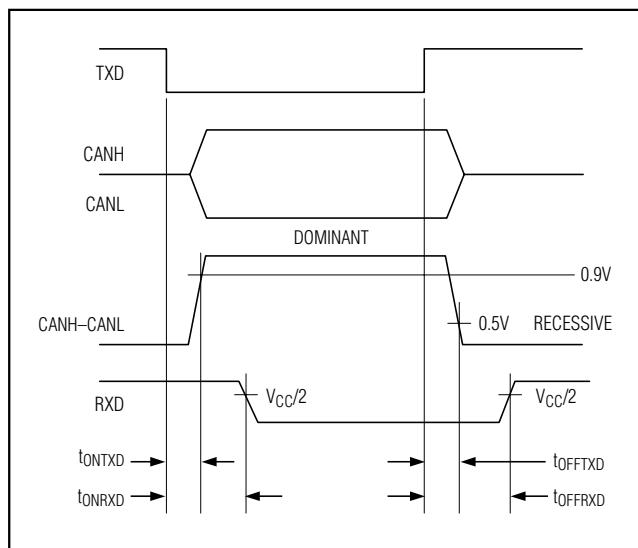

Figure 2. Timing Diagram for Dynamic Characteristics

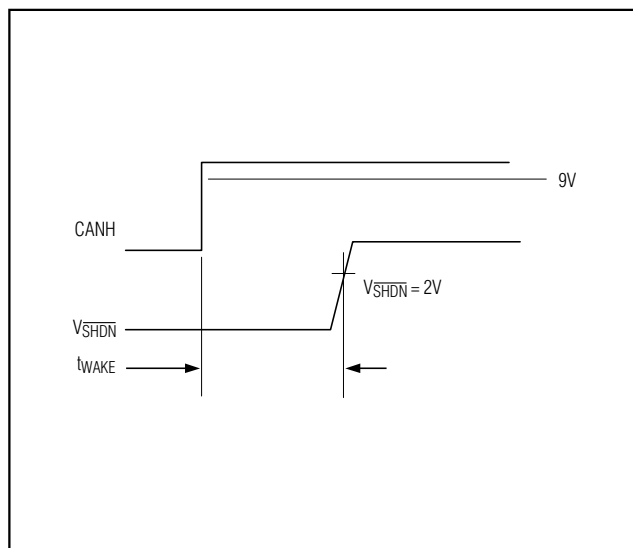

Figure 3. Time to Wakeup (t_{wake})

±80V Fault-Protected, 2Mbps, Low Supply Current CAN Transceiver

Detailed Description

The MAX3053 interfaces between the protocol controller and the physical wires of a CAN bus. It is primarily intended for industrial applications requiring data rates up to 2Mbps and features ±80V fault protection against shorts in high-voltage systems. This fault protection allows the device to withstand up to ±80V with respect to ground with no damage to the device. The built-in fault tolerance allows the device to survive in industrial and automotive environments with no external protection devices. The device provides differential transmit capability to the bus and differential receive capability to the CAN controller (Figure 4).

The device has three modes of operations: high-speed, slope control, and shutdown. In high-speed mode, slew rates are not limited, making 2Mbps transmission speeds possible. Slew rates are controlled in slope control mode, minimizing EMI and allowing use of unshielded twisted or parallel cable. The device goes into low-power operation in shutdown mode.

The transceiver is designed to operate from a single +5V supply, and draws 56mA of supply current in dominant state and 3.6mA in recessive state. In shutdown mode, supply current is reduced to 15µA.

CANH and CANL are output short circuit current limited and are protected against excessive power dissipation by thermal-shutdown circuitry that places the driver outputs into a high-impedance state.

Fault Protection

The MAX3053 features ±80V fault protection. This extended voltage range of CANH and CANL bus lines allows its use in high-voltage systems and communicating to high-voltage buses. If data is transmitting at 2Mbps, the fault protection is reduced to ±70V.

Transmitter

The transmitter converts a single-ended input (TXD) from the CAN controller to differential outputs for the bus lines (CANH, CANL). Table 1 is the truth table for the transmitter and receiver.

High Speed

Connect RS to ground to set the MAX3053 to high-speed mode. When operating in high-speed mode, the MAX3053 can achieve transmission rates up to 2Mbps. Line drivers are switched on and off as quickly as possible. However, in this mode, no measures are taken to limit the rise and fall slope of the data signal, allowing for potential EMI emissions. If using the MAX3053 in high-speed mode, use shielded twisted-pair cable to avoid EMI problems.

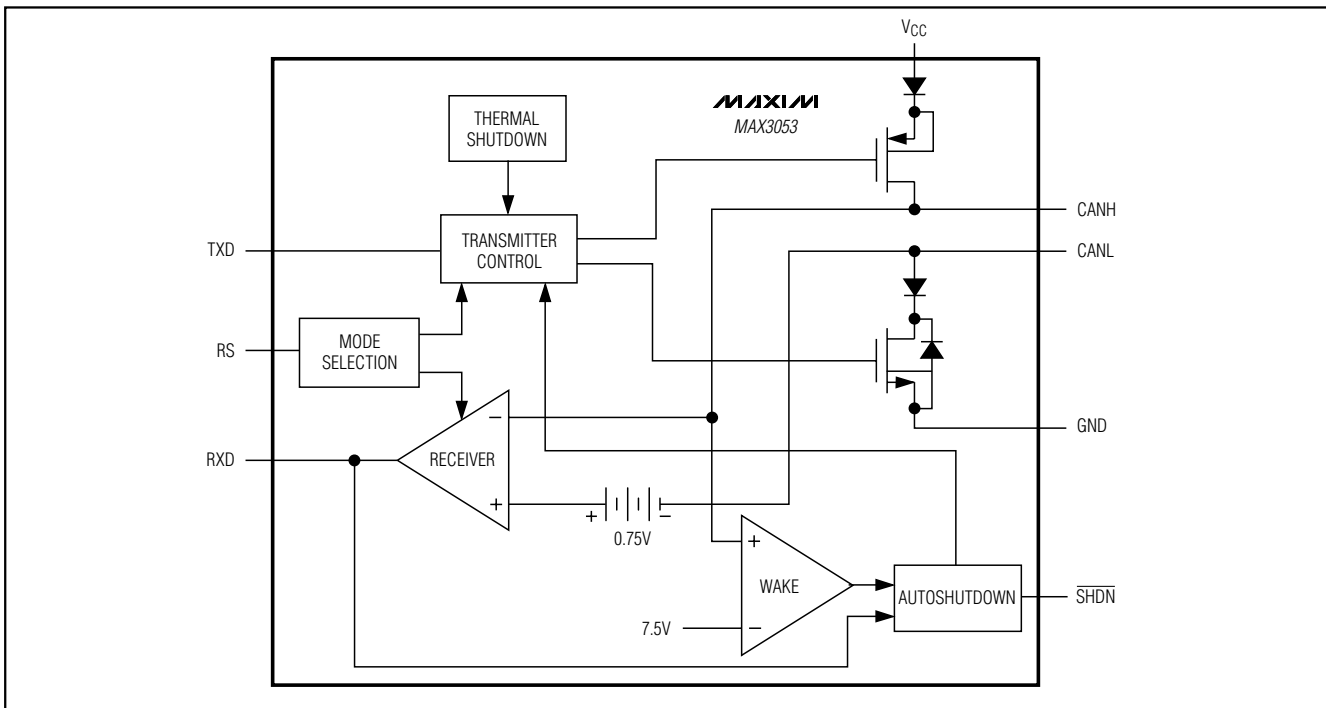

Figure 4. Block Diagram

±80V Fault-Protected, 2Mbps, Low Supply Current CAN Transceiver

Table 1. Transmitter and Receiver Truth Table

TXD	$\overline{\text{SHDN}}$	CANH	CANL	BUS STATE	RXD
0	$V_{\overline{\text{SHDN}}} > 1.5\text{V}$	HIGH	LOW	Dominant**	0
1 or float	$V_{\overline{\text{SHDN}}} > 1.5\text{V}$	5Ω to $25\text{k}\Omega$ to $V_{\text{CC}}/2$	5Ω to $25\text{k}\Omega$ to $V_{\text{CC}}/2$	Recessive**	1
X*	$V_{\overline{\text{SHDN}}} < 0.5\text{V}$	Floating	Floating	Floating	1

*X = Don't care.

**As defined by ISO, bus value is one of two complementary logical values: dominant or recessive. The dominant value represents the logical 0 and the recessive represents the logical 1. During the simultaneous transmission of the dominant and recessive bits, the resulting bus value is dominant.

Slope Control

Connect a resistor from RS to ground to select slope control mode (see Table 2). In slope control mode, the gates of the line drivers are charged with a controlled current, proportional to the resistor connected to the RS pin. Transmission speed ranges from 40kbps to 500kbps. Controlling the rise and fall slope reduces EMI and allows the use of an unshielded twisted pair or a parallel pair of wires as bus lines. The transfer function for selecting the resistor value is given by:

$$R_{RS} (\text{k}\Omega) = 12000 / \text{speed (in kbps)}.$$

See the *Typical Operating Characteristics* for the Slew Rate vs. R_{RS} graph.

Shutdown

To place the MAX3053 in shutdown, the $\overline{\text{SHDN}}$ pin should be driven to GND. In shutdown mode, the device is switched off. The outputs are high impedance to ±80V.

Receiver

The receiver takes differential input from the bus lines (CANH, CANL) and converts this data to a single-ended output (RXD) to the CAN controller. It consists of a comparator that senses the difference $\Delta V = (\text{CANH} - \text{CANL})$ with respect to an internal threshold of 0.7V. If this difference is positive (i.e., $\Delta V > 0.9\text{V}$), a logic low is present at the RXD pin. If negative (i.e., $\Delta V < 0.5\text{V}$), a logic high is present.

The receiver always echoes the transmitted data.

The CANH and CANL common-mode range is from -7V to +12V. RXD is logic high when CANH and CANL are shorted or terminated and undriven.

Thermal Shutdown

If the junction temperature exceeds +160°C, the device is switched off. The hysteresis is about 20°C, disabling thermal shutdown once the temperature declines to +140°C and the device is turned back on.

Table 2. Mode Selection Truth Table

CONDITION FORCED AT PIN RS	MODE	RESULTING CURRENT AT RS
$V_{RS} < 0.3V_{\text{CC}}$	High speed	$ I_{RS} < 500\mu\text{A}$
$0.4V_{\text{CC}} < V_{RS} < 0.6V_{\text{CC}}$	Slope control	$10\mu\text{A} < I_{RS} < 200\mu\text{A}$

Autoshutdown

To manage power consumption, autoshutdown puts the device into shutdown mode after the device has been inactive for a period of time. The value of an external capacitor ($C_{\overline{\text{SHDN}}}$) connected to $\overline{\text{SHDN}}$ determines the threshold of inactivity time, after which the autoshutdown triggers (see *Typical Operating Characteristics*).

Use a 100nF capacitor as $C_{\overline{\text{SHDN}}}$ for a typical threshold of 20ms. Change the capacitor value according to the following equation to change the threshold time period:

$$C_{\overline{\text{SHDN}}}(\text{nf}) = \frac{I_{\overline{\text{SHDN}}}(\mu\text{A}) \times \text{time (ms)}}{(V_{\text{CC}} - V_{\overline{\text{SHDN}}}(V))}$$

Drive $\overline{\text{SHDN}}$ high to force the MAX3053 on and disable autoshutdown.

When the MAX3053 is in shutdown mode, only the wakeup comparator is active, and normal bus communication is ignored. The remote master of the CAN system wakes up the MAX3053 with a signal greater than 9V on CANH. The local CAN controller wakes up the MAX3053 by driving $\overline{\text{SHDN}}$ high or TXD.

Driver Output Protection

The MAX3053 has several features to protect itself from damage. Thermal shutdown switches off the device and puts CANH and CANL into high impedance if the junction temperature exceeds +160°C. Thermal protection is needed particularly when a bus line is short circuited. The hysteresis for the thermal shutdown is about 20°C.

±80V Fault-Protected, 2Mbps, Low Supply Current CAN Transceiver

Additionally, a current-limiting circuit protects the transmitter output stage against a short circuit to positive and negative battery voltage. Although the power dissipation increases during this fault condition, this feature prevents destruction of the transmitter output stage.

Applications Information Reduced EMI and Reflections

In slope control mode, the CANH, CANL outputs are slew-rate limited, minimizing EMI and reducing reflections caused by improperly terminated cables. In general, a transmitter's rise time relates directly to the

length of an unterminated stub, which can be driven with only minor waveform reflections. The following equation expresses this relationship conservatively:

$$\text{Length} = t_{\text{RISE}} / (10 \times 1.5\text{ns/ft})$$

where t_{RISE} is the transmitter's rise time. See Figures 5, 6, and 7 for typical waveforms at various data rates.

The MAX3053 requires no special layout considerations beyond common practices. Bypass V_{CC} to GND with a $1\mu\text{F}$ ceramic capacitor mounted close to the IC with short lead lengths and wide trace widths.

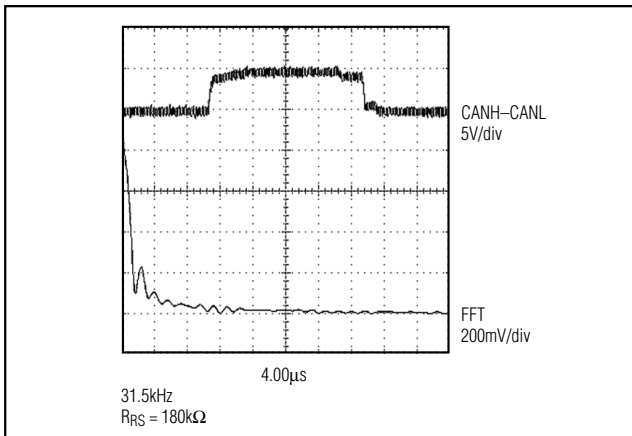

Figure 5. Output Bus in Slope Control Mode at 62.5kbps

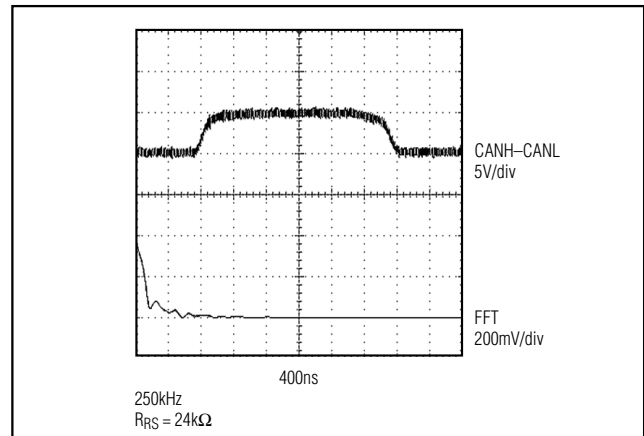

Figure 6. Output Bus in Slope Control Mode at 500kbps

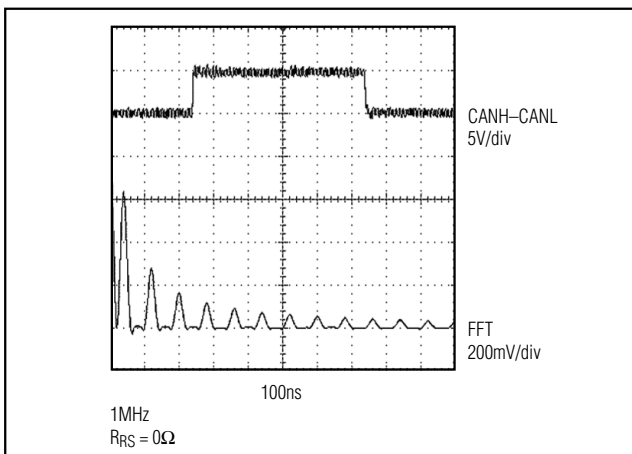
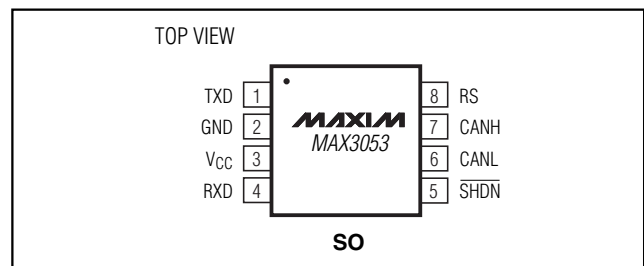

Figure 7. Output Bus High-Speed Mode at 2Mbps

Pin Configuration



Chip Information

TRANSISTOR COUNT: 1214
PROCESS: BiCMOS

±80V Fault-Protected, 2Mbps, Low Supply Current CAN Transceiver

Package Information

(The package drawing(s) in this data sheet may not reflect the most current specifications. For the latest package outline information, go to www.maxim-ic.com/packages.)

MAX3053

9LUCSP, 3x3.EPS

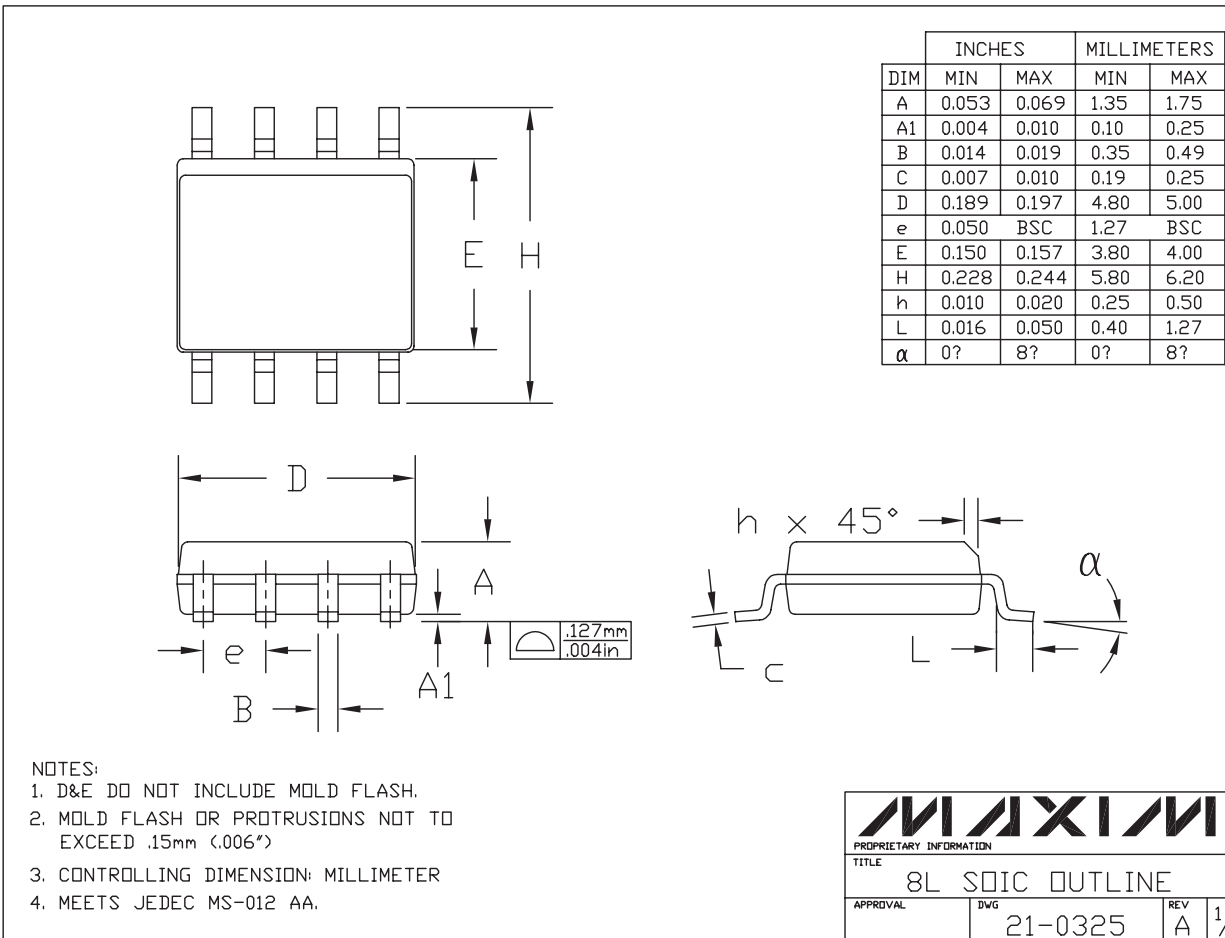

Maxim cannot assume responsibility for use of any circuitry other than circuitry entirely embodied in a Maxim product. No circuit patent licenses are implied. Maxim reserves the right to change the circuitry and specifications without notice at any time.

Maxim Integrated Products, 120 San Gabriel Drive, Sunnyvale, CA 94086 408-737-7600 11