

## Features

- **Industry Standard Serial ATA (SATA) Host Interface**
    - SATA 1.5 Gb/s or SATA 3.0 Gb/s <sup>1)</sup>
    - ATA/ATAPI-8 compliant
    - Supports 48-bit address feature set
  - **Performance**
    - Sequential data read - Up to 70 MByte/sec\*
    - Sequential data write - Up to 60 MByte/sec\*
    - \* measured using 128 KByte transfer size
  - **Power Management**
    - 3.3V and 1.2V power supply
    - Host SATA interface power management
    - Immediate disabling of unused circuitry without host intervention
  - **Power Specifications** <sup>2)</sup>
    - Active mode:  
750mW typical (GLS85LS1008P)  
560mW typical (GLS85LS1004P)  
450mW typical (GLS85LS1002P)
    - Idle mode: 210mW typical
    - Standby mode: 190mW typical
  - **Integrated Voltage Detector**
    - Detects supply voltage fluctuations and generates reset during power-up and power-down to prevent inadvertent writes
  - **Supports SMART Commands**
  - **Expanded Data Protection**
    - Added data security through user-selectable protection zones
  - **20-Byte Serial Number**
    - Factory pre-programmed 10-Byte unique ID
    - User-programmable 10-Byte ID
  - **Robust Built-in ECC**
  - **NAND Configuration**
    - 1 bit per cell (SLC)
  - **Industrial Temperature Range**
    - -40°C to 85°C
  - **FBGA package**
    - 14.0 mm x 24.0 mm x 1.95 mm, 145-ball, 1.0 mm ball pitch, FZJE
  - **All Devices are RoHS Compliant**
- 1) Current product revision will only support SATA Revision 1.x with host transfer rate of up to 1.5 Gb/s (i.e. SATA 1.5 Gb/s). SATA 3.0 Gb/s refers to SATA Revision 2.x and is planned to be supported by our future product revisions.
- 2) For management of the Sleep Mode, please refer to "SATA NANDrive Application Design Guide."

## Product Description

The GLS85LS1002P / 1004P / 1008P Industrial Grade SATA NANDrive™ devices (referred to as "SATA NANDrive" in this datasheet) are fully integrated solid state drives. They combine an advanced Greenliant NAND controller and 2, 4 or 8 GByte of NAND flash in a multi-chip package. These products are ideal for embedded and portable applications that require smaller form-factor and more reliable data storage.

SATA-interface solid state mass storage technology is widely used in portable and industrial computers, set-top boxes, multi-functional printers, point-of-sales terminals, video and audio recorders, medical instruments and car infotainment systems.

SATA NANDrive is a single device, solid state drive (SSD) that provides the functionality and compatibility of a complete SATA hard disk drive (HDD) in a 14 mm x 24 mm BGA package for easy, space saving mounting to a system motherboard. These products surpass traditional storage in their small size, security, reliability, ruggedness and low power consumption.

The integrated NAND flash controller with built-in advanced NAND management firmware communicates with the Host through the standard SATA protocol. It does not require any additional or proprietary software such as the Flash File System (FFS) and Memory Technology Driver (MTD).

SATA NANDrive is pre-programmed with a 10-Byte unique serial ID and has the option of programming an additional 10-Byte serial ID for even greater system security.

SATA NANDrive's advanced NAND management technology enhances data reliability and security, improves endurance and accurately estimates the remaining life of the NAND flash devices. This innovative technology combines robust NAND controller hardware error correction capabilities with advanced wear-leveling algorithms and bad block management to significantly extend the life of the product.

SATA NANDrive devices are offered in a 145-ball BGA, 1 mm ball pitch package. Please refer to Figure 3-1 for the pin assignments.

## **1.0 GENERAL DESCRIPTION**

Each SATA NANDrive contains an integrated SATA NAND flash memory controller and up to eight discrete NAND flash die in a BGA package. Refer to Figure 2-1 for the SATA NANDrive block diagram.

### **1.1 Optimized SATA NANDrive**

The heart of SATA NANDrive is the SATA NAND flash memory controller which translates standard SATA signals into flash media data and control signals. The following components contribute to SATA NANDrive's operation.

#### **1.1.1 Microcontroller Unit (MCU)**

The MCU translates SATA commands into data and control signals required for flash media operation.

#### **1.1.2 Internal Direct Memory Access (DMA)**

SATA NANDrive uses internal DMA allowing instant data transfer from/to buffer to/from flash media. This implementation eliminates microcontroller overhead associated with the traditional, firmware-based approach, thereby increasing the data transfer rate.

#### **1.1.3 Power Management Unit (PMU)**

The PMU controls the power consumption of SATA NANDrive. The PMU dramatically reduces the power consumption of SATA NANDrive by putting the part of the circuitry that is not in operation into sleep mode.<sup>3)</sup>

The Flash File System handles inadvertent power interrupts and has auto-recovery capability to ensure SATA NANDrive firmware integrity. For regular power management, the Host must send an IDLE\_IMMEDIATE command and wait for command ready before powering down SATA NANDrive.

<sup>3)</sup> For management of the Sleep Mode, please refer to "SATA NANDrive Application Design Guide."

#### **1.1.4 Embedded Flash File System**

The embedded flash file system is an integral part of SATA NANDrive. It contains MCU firmware that performs the following tasks:

1. Translates host side signals into flash media writes and reads
2. Provides flash media wear leveling to spread the flash writes across all memory address space to increase the longevity of flash media
3. Keeps track of data file structures
4. Manages system security for the selected protection zones

#### **1.1.5 Error Correction Code (ECC)**

High performance is achieved through optimized hardware error detection and correction.

#### **1.1.6 Serial Communication Interface (SCI)**

The Serial Communication Interface (SCI) is designed for error reporting. During the product development stage, it is recommended to provide the SCI port on the PCB to aid in design validation.

#### **1.1.7 Multi-tasking Interface**

The multi-tasking interface enables fast, sequential write performance by allowing concurrent Read, Program and Erase operations to multiple flash media.

## **1.2 SMT Reflow Consideration**

The SATA NANDrive family utilizes standard NAND flash for data storage. Because the high temperature in a surface-mount soldering reflow process may alter the content on NAND flash, it is recommended to program SATA NANDrive after the reflow process.

## **1.3 Advanced NAND Management**

SATA NANDrive's integrated controller uses advanced wear-leveling algorithms to substantially increase the longevity of NAND flash media. Wear caused by data writes is evenly distributed in all or select blocks in the device that prevents "hot spots" in locations that are programmed and erased extensively. This effective wear-leveling technique results in optimized device endurance, enhanced data retention and higher reliability required by long-life applications.

## 2.0 FUNCTIONAL BLOCKS

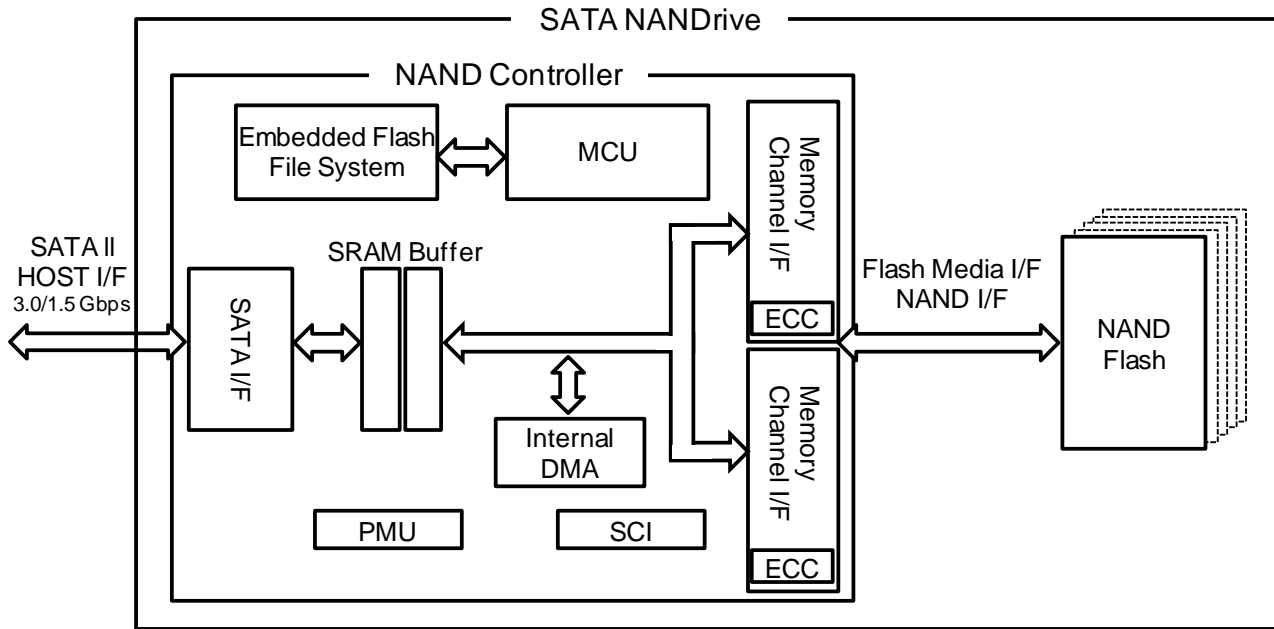

Figure 2-1: SATA NANDrive Block Diagram

## 3.0 PIN ASSIGNMENTS

The signal/pin assignments are listed in Table 3-1. Low active signals have a “#” suffix. Pin types are Input, Output or Input/Output.

TOP VIEW (balls facing down)

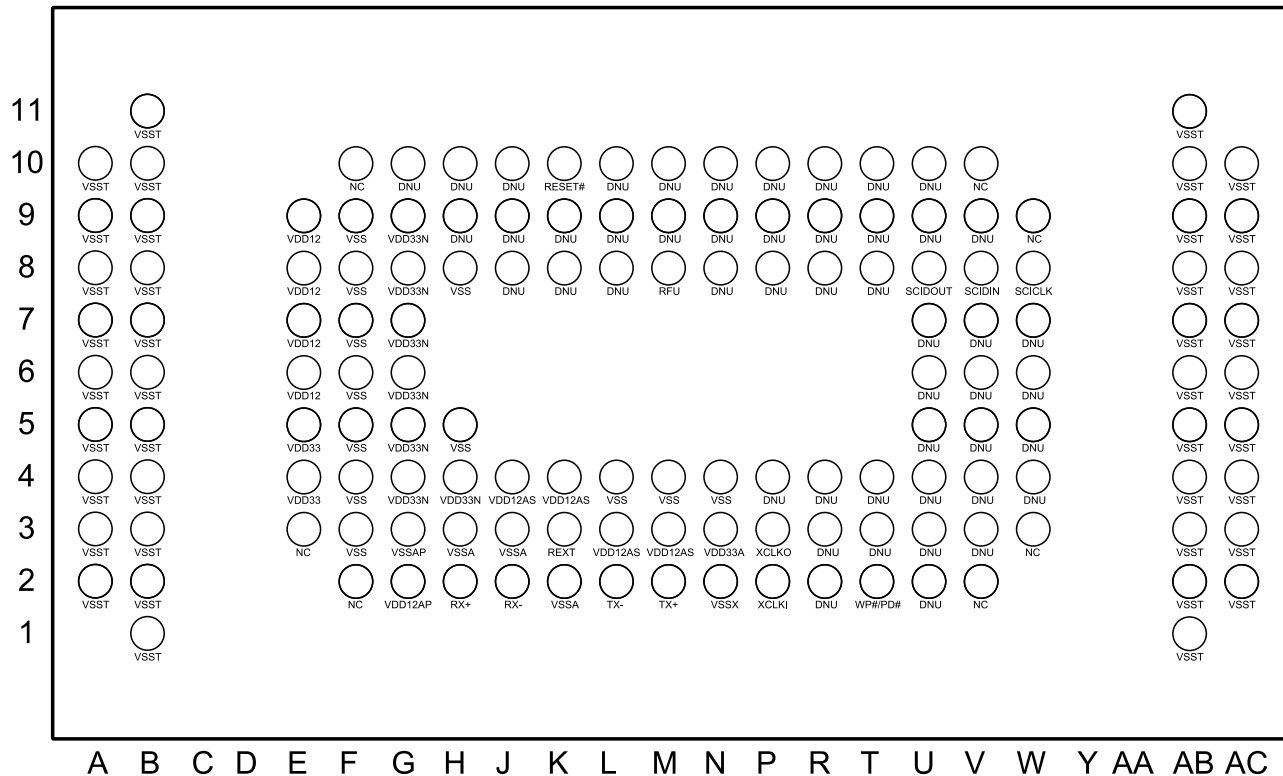

Figure 3-1: Pin Assignments for 145-Ball BGA

**Table 3-1: Pin Assignments**

Symbol	Ball No.	Ball Type	IO Type	Name and Functions
<b>Host Side Interface</b>				
RX+	H2	I	I3	Analog Differential Input (+)
RX-	J2	I	I3	Analog Differential Input (-)
TX+	M2	O	O3	Analog Differential Output (+)
TX-	L2	O	O3	Analog Differential Output(-)
<b>Serial Communication Interface (SCI)</b>				
SCID <sub>IN</sub>	V8	I	I2U	SCI port data input
SCID <sub>OUT</sub>	U8	O	O1	SCI port data output. No external pull-up or pull-down resistor should connect to this signal.
SCICLK	W8	I	I2D	SCI port clock
<b>Miscellaneous</b>				
RFU	M8			Reserved for Future Use
Rext	K3	I	I3	External Resistor, 1Kohms (1%) connected to GND
RESET#	K10	I	I2U	This input is the active low hardware reset from host.
WP#/PD#	T2 <sup>4)</sup>	I	I2U	The WP#/PD# can be used for either the Write Protect mode or Power Down mode, but only one mode is active at any time. The Write Protect or Power-down modes can be selected through the host command. The Write Protect mode is the factory default setting.
XCLKI	P2	I	XI	External clock source input for main clock; 25MHz crystal, need external 20pf capacitor to ground
XCLKO	P3	O	XO	External clock source output for main clock; 25MHz crystal, need external 20pf capacitor to ground
NC	E3, F2, F10, V2, V10, W3, W9			No connect
DNU	G10, H9, H10, J8, J9, J10, K8, K9, L8, L9, L10, M9, M10, N8, N9, N10, P4, P8, P9, P10, R2, R3, R4, R8, R9, R10, T3, T4, T8, T9, T10, U2, U3, U4, U5, U6, U7, U9, U10, V3, V4, V5, V6, V7, V9, W4, W5, W6, W7			Do Not Use. All these pins should not be connected.
<b>Power and Ground</b>				
V <sub>DD33</sub>	E4, E5	Digital PWR		Supply voltage 3.3V
V <sub>DD33A</sub>	N3	Analog PWR		
V <sub>DD33N</sub>	G4, G5, G6, G7, G8, G9, H4	Digital PWR		
V <sub>DD12</sub>	E6, E7, E8, E9	Digital PWR		Supply voltage 1.2V
V <sub>DD12AS</sub>	J4, K4, L3, M3	Analog PWR		Analog supply voltage 1.2V (200mA max. total for both 1.2V analog power rails, V <sub>DD12AS</sub> and V <sub>DD12AP</sub> )
V <sub>DD12AP</sub>	G2	Analog PWR		
V <sub>SS</sub>	F3, F4, F5, F6, F7, F8, F9, H5, H8, L4, M4, N4	Digital GND		Digital ground
V <sub>SSX</sub>	N2	Analog GND		Analog ground
V <sub>SST</sub>	A2, A3, A4, A5, A6, A7, A8, A9, A10, B1, B2, B3, B4, B5, B6, B7, B8, B9, B10, B11, AB1, AB2, AB3, AB4, AB5, AB6, AB7, AB8, AB9, AB10, AB11, AC2, AC3, AC4, AC5, AC6, AC7, AC8, AC9, AC10	GND		Connected to PCB ground plane for thermal dissipation. Not connected to any internal signal.
V <sub>SSA</sub>	H3, J3, K2	Analog GND		Analog ground
V <sub>SSAP</sub>	G3			Analog ground

**Table 3-2: I/O Type**

I/O Type	Description
I3	Analog Input
O3	Analog Output
I2D	Input with Pull-down
I2U	Input with Pull-up
O1	Output
XI	Crystal Clock Input
XO	Crystal Clock Output

- 4) The command to configure the T2 pin in either PD# or WP# is prepared by the vendor-unique command. Please ask your Greenliant contact for details on the SMART command specification.

**4.0 Product Ordering Information**

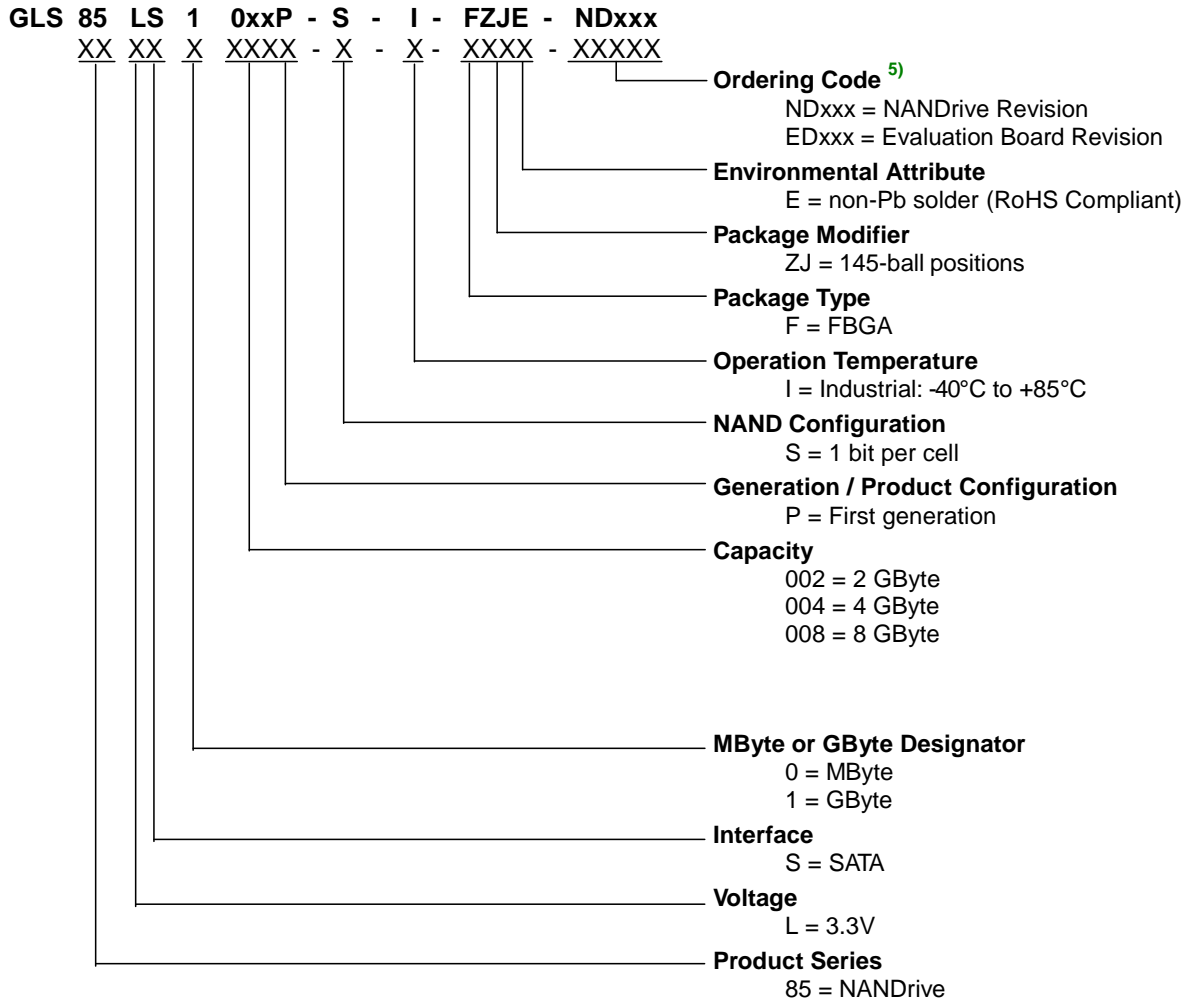

**Valid Combinations**

**SATA NANDrive Product**  
 GLS85LS1002P-S-I-FZJE,

GLS85LS1004P-S-I-FZJE,

GLS85LS1008P-S-I-FZJE

**SATA NANDrive Evaluation Board, (1S: SATA Interface EVB, K: Kit)**  
 GLS85LS1002P-S-I-1S-K,

GLS85LS1004P-S-I-1S-K,

GLS85LS1008P-S-I-1S-K

**SATA NANDrive mini-SATA Evaluation Board, (1mS: mini-SATA Interface EVB, K: Kit)**

GLS85LS1002P-S-I-1MS-K,

GLS85LS1004P-S-I-1MS-K,

GLS85LS1008P-S-I-1MS-K

Valid product combinations are those that are in the mass production or will be in the mass production. Consult your Greenliant sales representative to confirm availability of the valid product combinations and to determine availability of new product combinations.

<sup>5)</sup> For Legacy NANDrive products, no ordering code is required. Special ordering codes may be used for custom NANDrive products (i.e. C-SPEC).

### 4.1 Package Diagram

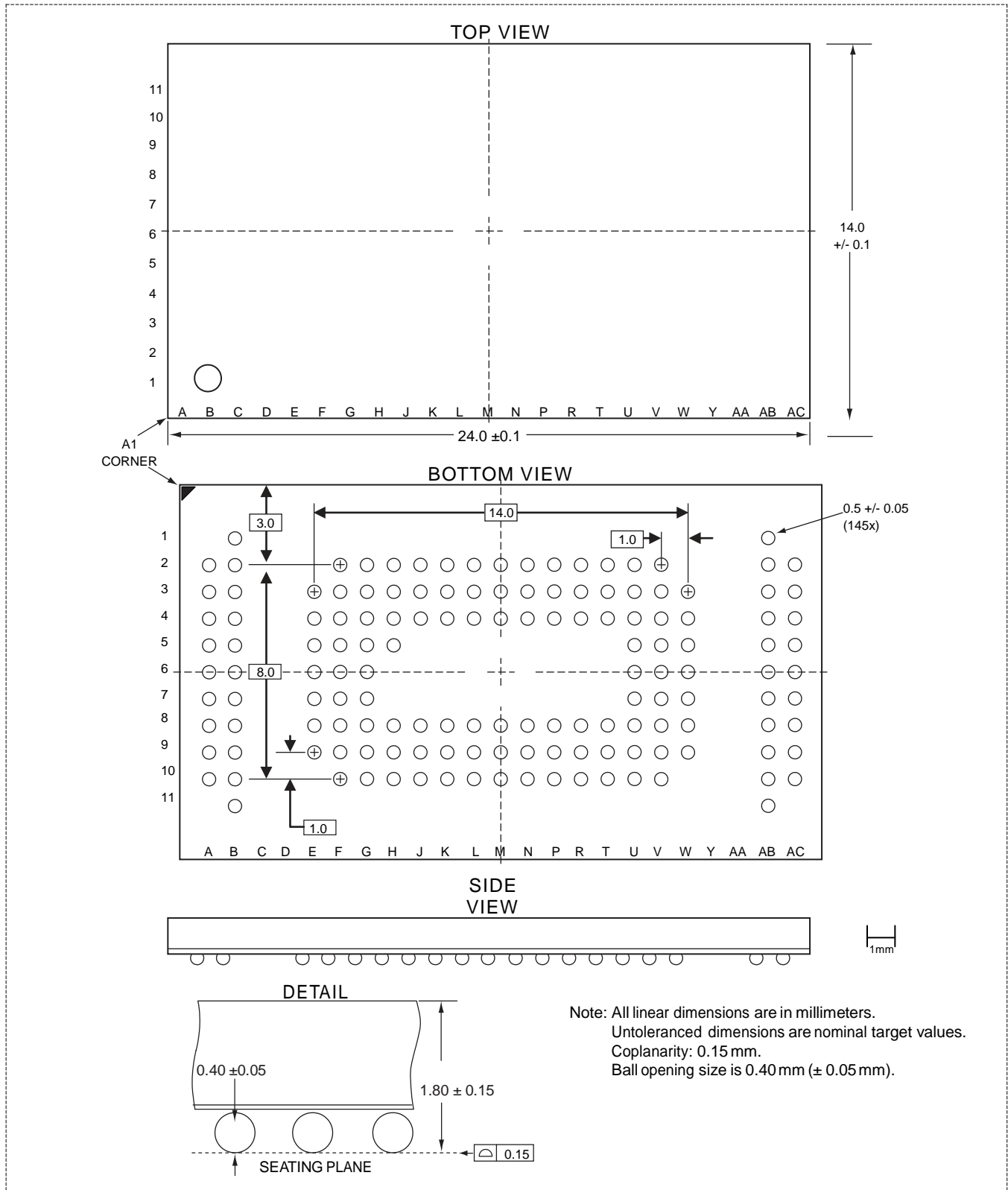

Figure 12-2: SATA NANDrive 145-Ball, Ball Grid Array (BGA) Greenliant Package Code: FZJ

## Revision History

Revision	Description	Date
01.000	Initial release of Fact Sheet for GLS85LS1002P/1004P/1008P	October 17, 2011
01.001	Updated Table 3-1	December 22, 2011
01.002	Corrected typo in Table 3-1	March 12, 2012
02.000	Added part numbers GLS85LS1016P/1032P and updated Section 1.2	April 9, 2012
02.100	Separated part numbers GLS85LS1016P/1032P to document S71445-F Updated Table 3-1; Updated Section 4.0	January 18, 2013

© 2013 Greenliant Systems. All rights reserved.

Greenliant and the Greenliant logo are registered trademarks, and NANDrive is a trademark of Greenliant Systems. All other trademarks and registered trademarks are the property of their respective owners.

Specifications are subject to change without notice. Memory sizes denote raw storage capacity; actual usable capacity may be less.

Greenliant makes no warranty for the use of its products other than those expressly contained in the Greenliant Terms and Conditions of Sale.

[www.greenliant.com](http://www.greenliant.com)