

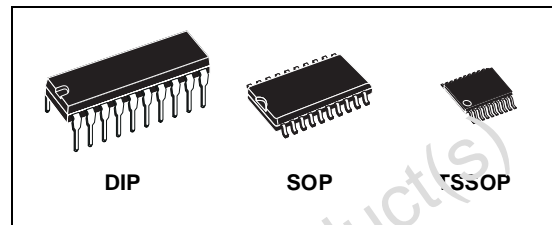

M74HCT241

OCTAL BUS BUFFER WITH 3 STATE OUTPUTS (NON INVERTED)

- HIGH SPEED:
 $t_{PD} = 15 \text{ ns}$ (TYP.) at $V_{CC} = 4.5V$
- LOW POWER DISSIPATION:
 $I_{CC} = 4\mu A$ (MAX.) at $T_A = 25^\circ C$
- COMPATIBLE WITH TTL OUTPUTS :
 $V_{IH} = 2V$ (MIN.) $V_{IL} = 0.8V$ (MAX)
- BALANCED PROPAGATION DELAYS:
 $t_{PLH} \cong t_{PHL}$
- SYMMETRICAL OUTPUT IMPEDANCE:
 $|I_{OH}| = I_{OL} = 6mA$ (MIN)
- PIN AND FUNCTION COMPATIBLE WITH
74 SERIES 241



ORDER CODES

| PACKAGE | TYPE | T & R |
|---------|--------------|-----------------|
| DIP | M74HCT241B1R | |
| SOP | M74HCT241M1R | M74HCT241RM13TR |
| TSOP | | M74HCT241TTR |

DESCRIPTION

The 74HCT241 is an advanced high-speed CMOS OCTAL BUS BUFFER (3-STATE) fabricated with silicon gate C²MOS technology. Each control input governs four BUS BUFFERS.

All inputs are equipped with protection circuits against static discharge and transient excess voltage.

PIN CONNECTION AND IEC LOGIC SYMBOLS

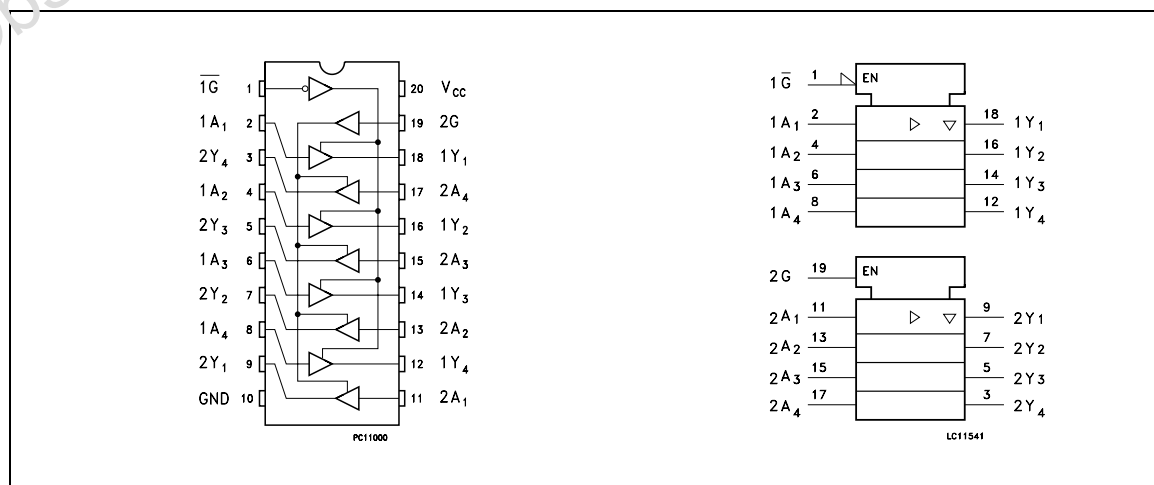

M74HCT241

INPUT AND OUTPUT EQUIVALENT CIRCUIT

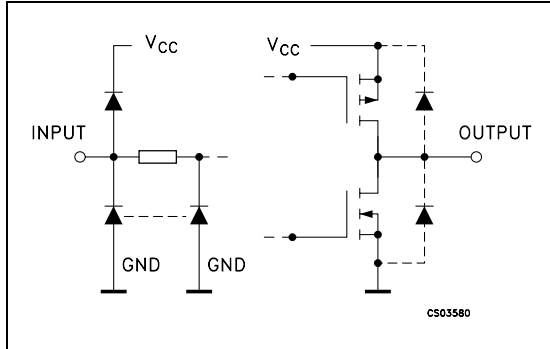

PIN DESCRIPTION

| PIN No | SYMBOL | NAME AND FUNCTION |
|----------------|-----------------|-------------------------|
| 1 | 1G | Output Enable Input |
| 2, 4, 6, 8 | 1A1 to 1A4 | Data Inputs |
| 9, 7, 5, 3 | 2Y1 to 2Y4 | Data Outputs |
| 11, 13, 15, 17 | 2A1 to 2A4 | Data Inputs |
| 18, 16, 14, 12 | 1Y1 to 1Y4 | Data Outputs |
| 19 | 2G | Output Enable Input |
| 10 | GND | Ground (0V) |
| 20 | V _{CC} | Positive Supply Voltage |

TRUTH TABLE

| INPUTS | | OUTPUT | INPUTS | | OUTPUT |
|-----------------|-----|--------|--------|-----|--------|
| $\overline{1G}$ | 1An | 1Yn | 2G | 2An | 2Yn |
| L | L | L | H | L | L |
| L | H | H | H | H | H |
| H | X | Z | L | X | Z |

X : Don't Care
Z : High Impedance

ABSOLUTE MAXIMUM RATINGS

| Symbol | Parameter | Value | Unit |
|-------------------------------------|--------------------------------------|-------------------------------|------|
| V _{CC} | Supply Voltage | -0.5 to +7 | V |
| V _I | DC Input Voltage | -0.5 to V _{CC} + 0.5 | V |
| V _O | DC Output Voltage | -0.5 to V _{CC} + 0.5 | V |
| I _{IK} | DC Input Diode Current | ± 20 | mA |
| I _{OK} | DC Output Diode Current | ± 20 | mA |
| I _O | DC Output Current | ± 35 | mA |
| I _{CC} or I _{CND} | DC V _{CC} or Ground Current | ± 70 | mA |
| F _D | Power Dissipation | 500(*) | mW |
| T _{stg} | Storage Temperature | -65 to +150 | °C |
| T _L | Lead Temperature (10 sec) | 300 | °C |

Absolute Maximum Ratings are those values beyond which damage to the device may occur. Functional operation under these conditions is not implied.

(*) 500mW at 65 °C; derate to 300mW by 10mW/°C from 65°C to 85°C

RECOMMENDED OPERATING CONDITIONS

| Symbol | Parameter | Value | Unit |
|---------------------------------|--|----------------------|------|
| V _{CC} | Supply Voltage | 4.5 to 5.5 | V |
| V _I | Input Voltage | 0 to V _{CC} | V |
| V _O | Output Voltage | 0 to V _{CC} | V |
| T _{op} | Operating Temperature | -55 to 125 | °C |
| t _r , t _f | Input Rise and Fall Time (V _{CC} = 4.5 to 5.5V) | 0 to 500 | ns |

DC SPECIFICATIONS

| Symbol | Parameter | Test Condition | | Value | | | | | | Unit | |
|-------------------|---------------------------------------|------------------------|---|-----------------------|------|-------|-------------|------|--------------|------|------|
| | | V _{CC} (V) | | T _A = 25°C | | | -40 to 85°C | | -55 to 125°C | | |
| | | | | Min. | Typ. | Max. | Min. | Max. | Min. | | Max. |
| V _{IH} | High Level Input Voltage | 4.5 to 5.5 | | 2.0 | | | 2.0 | | 2.0 | | V |
| V _{IL} | Low Level Input Voltage | 4.5 to 5.5 | | | | 0.8 | | 0.8 | | 0.8 | V |
| V _{OH} | High Level Output Voltage | 4.5 | I _O =-20 μA | 4.4 | 4.5 | | 4.4 | | 4.4 | | V |
| | | | I _O =-6.0 mA | 4.18 | 4.31 | | 4.13 | | 4.10 | | |
| V _{OL} | Low Level Output Voltage | 4.5 | I _O =20 μA | | 0.0 | 0.1 | | 0.1 | | 0.1 | V |
| | | | I _O =6.0 mA | | 0.17 | 0.26 | | 0.33 | | 0.40 | |
| I _I | Input Leakage Current | 5.5 | V _I = V _{CC} or GND | | | ± 0.1 | | ± 1 | | ± 1 | μA |
| I _{OZ} | High Impedance Output Leakage Current | 5.5 | V _I = V _{IH} or V _{IL} V _O = V _{CC} or GND | | | ± 0.5 | | ± 5 | | ± 10 | μA |
| I _{CC} | Quiescent Supply Current | 5.5 | V _I = V _{CC} or GND | | | 4 | | 40 | | 80 | μA |
| Δ I _{CC} | Additional Worst Case Supply Current | 5.5 | Per Input pin V _I = 0.5V or V _I = 2.4V Other Inputs at V _{CC} or GND | | | 2.0 | | 2.9 | | 3.0 | mA |

AC ELECTRICAL CHARACTERISTICS (C_L = 50 pF, Input t_r = t_f = 6ns)

| Symbol | Parameter | Test Condition | | Value | | | | | | Unit | |
|-----------------------------------|------------------------|------------------------|------------------------|-----------------------|------|------|-------------|------|--------------|------|------|
| | | V _{CC} (V) | C _L (pF) | T _A = 25°C | | | -40 to 85°C | | -55 to 125°C | | |
| | | | | Min. | Typ. | Max. | Min. | Max. | Min. | | Max. |
| t _{TLH} t _{THL} | Output Transition Time | 4.5 | 50 | | 7 | 12 | | 15 | | 18 | ns |
| t _{PLH} t _{PHL} | Propagation Delay Time | 4.5 | 50 | | 15 | 22 | | 28 | | 33 | ns |
| | | 4.5 | 150 | | 21 | 30 | | 38 | | 45 | |
| t _{PLH} t _{PHL} | Propagation Delay Time | 4.5 | 50 | | 15 | 25 | | 31 | | 38 | ns |
| | | 4.5 | 150 | | 21 | 33 | | 41 | | 50 | |
| t _{PZL} t _{PZH} | Output Enable Time | 4.5 | 50 | R _L = 1 KΩ | 17 | 30 | | 38 | | 45 | ns |
| | | 4.5 | 150 | | 23 | 38 | | 48 | | 57 | |
| t _{PLZ} t _{PHZ} | Output Disable Time | 4.5 | 50 | R _L = 1 KΩ | 16 | 30 | | 38 | | 45 | ns |

M74HCT241

CAPACITIVE CHARACTERISTICS

| Symbol | Parameter | Test Condition | | Value | | | | | | Unit | |
|------------------|--|---------------------|--|-----------------------|------|------|-------------|------|--------------|------|------|
| | | | | T _A = 25°C | | | -40 to 85°C | | -55 to 125°C | | |
| | | V _{CC} (V) | | Min. | Typ. | Max. | Min. | Max. | Min. | | Max. |
| C _{IN} | Input Capacitance | | | | 5 | 10 | | 10 | | 10 | pF |
| C _{OUT} | Output Capacitance | | | | 10 | | | | | | pF |
| C _{PD} | Power Dissipation Capacitance (note 1) | | | | 31 | | | | | | pF |

1) C_{PD} is defined as the value of the IC's internal equivalent capacitance which is calculated from the operating current consumption without load. (Refer to Test Circuit). Average operating current can be obtained by the following equation. $I_{CC(opr)} = C_{PD} \times V_{CC} \times f_{IN} + I_{CC(0)}$ (per circuit)

TEST CIRCUIT

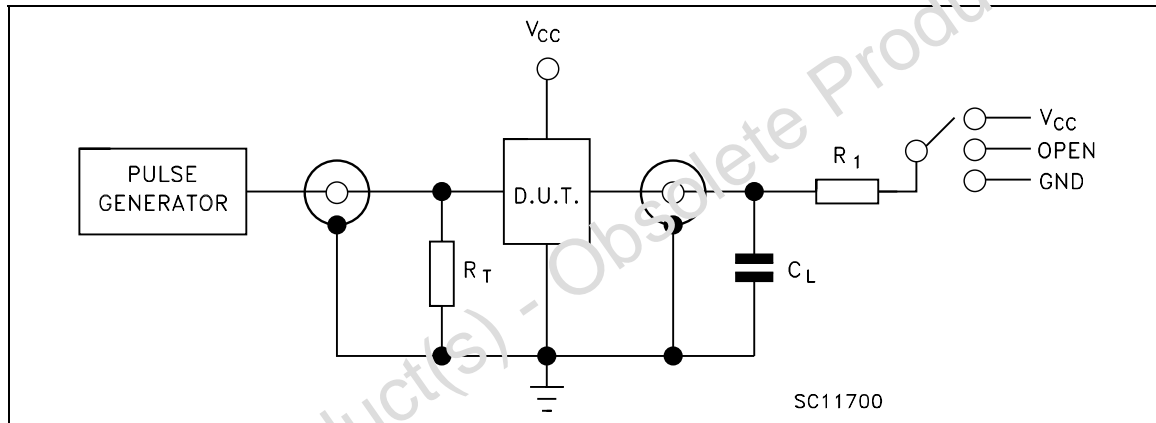

| TEST | SWITCH |
|-------------------------------------|-----------------|
| t _{PLH} , t _{PHL} | Open |
| t _{PZL} , t _{PLZ} | V _{CC} |
| t _{PZH} , t _{PHZ} | GND |

C_L = 50 pF / 150 pF or equivalent (includes jig and probe capacitance)

R₁ = 11 Ω or equivalent

R_T = Z_{OUT} of pulse generator (typically 50 Ω)

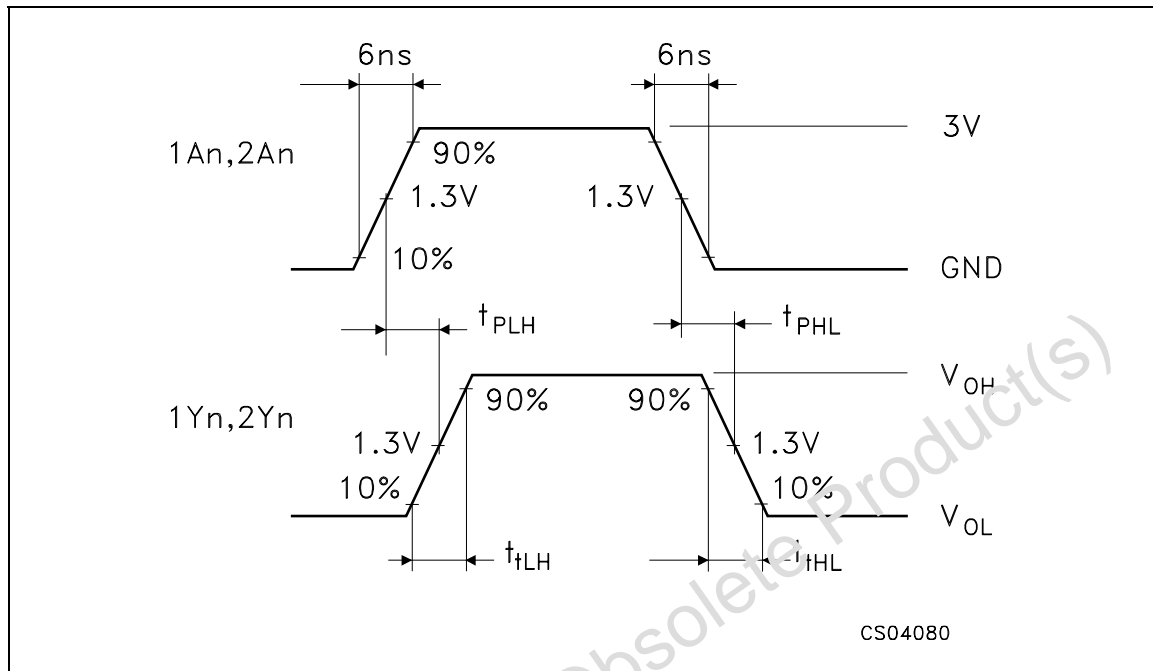
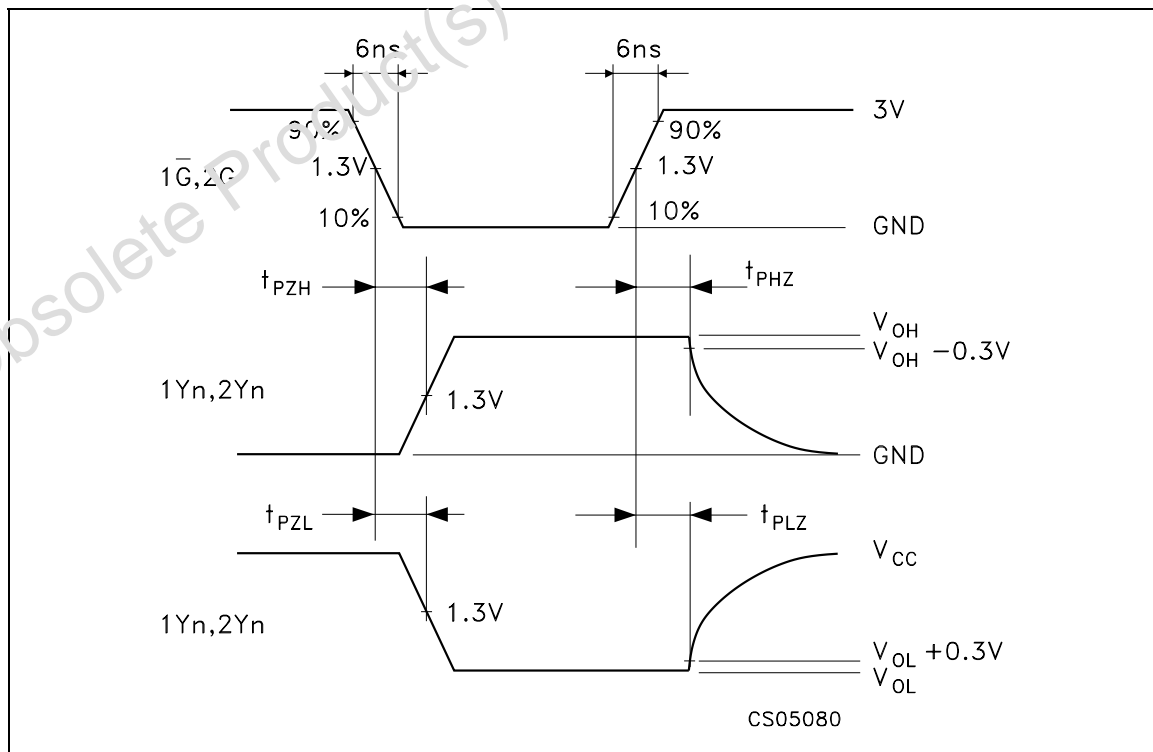
WAVEFORM 1 : PROPAGATION DELAY TIMES (f=1MHz; 50% duty cycle)**WAVEFORM 2 : OUTPUT AND ENABLE TIMES** (f=1MHz; 50% duty cycle)

Plastic DIP-20 (0.25) MECHANICAL DATA

| DIM. | mm. | | | inch | | |
|------|-------|-------|------|-------|-------|-------|
| | MIN. | TYP. | MAX. | MIN. | TYP. | MAX. |
| a1 | 0.254 | | | 0.010 | | |
| B | 1.39 | | 1.65 | 0.055 | | 0.065 |
| b | | 0.45 | | | 0.018 | |
| b1 | | 0.25 | | | 0.010 | |
| D | | | 25.4 | | | 1.000 |
| E | | 8.5 | | | 0.335 | |
| e | | 2.54 | | | 0.100 | |
| e3 | | 22.86 | | | 0.900 | |
| F | | | 7.1 | | | 0.280 |
| I | | | 3.93 | | | 0.155 |
| L | | 3.3 | | | 0.130 | |
| Z | | | 1.34 | | | 0.053 |

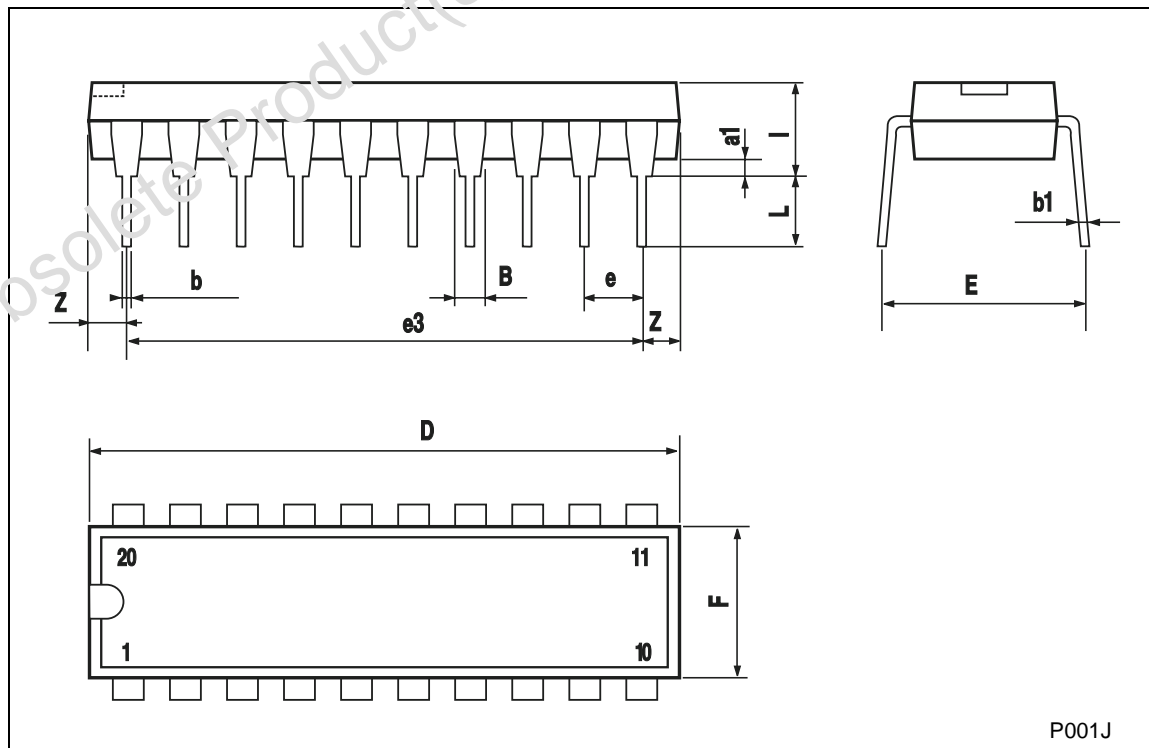

P001J

SO-20 MECHANICAL DATA

| DIM. | mm. | | | inch | | |
|------|------------|-------|-------|-------|-------|-------|
| | MIN. | TYP. | MAX. | MIN. | TYP. | MAX. |
| A | | | 2.65 | | | 0.104 |
| a1 | 0.1 | | 0.2 | 0.004 | | 0.008 |
| a2 | | | 2.45 | | | 0.096 |
| b | 0.35 | | 0.49 | 0.014 | | 0.019 |
| b1 | 0.23 | | 0.32 | 0.009 | | 0.012 |
| C | | 0.5 | | | 0.020 | |
| c1 | 45° (typ.) | | | | | |
| D | 12.60 | | 13.00 | 0.496 | | 0.512 |
| E | 10.00 | | 10.65 | 0.393 | | 0.419 |
| e | | 1.27 | | | 0.050 | |
| e3 | | 11.43 | | | 0.450 | |
| F | 7.40 | | 7.60 | 0.291 | | 0.300 |
| L | 0.50 | | 1.27 | 0.020 | | 0.050 |
| M | | | 0.75 | | | 0.029 |
| S | 8° (max.) | | | | | |

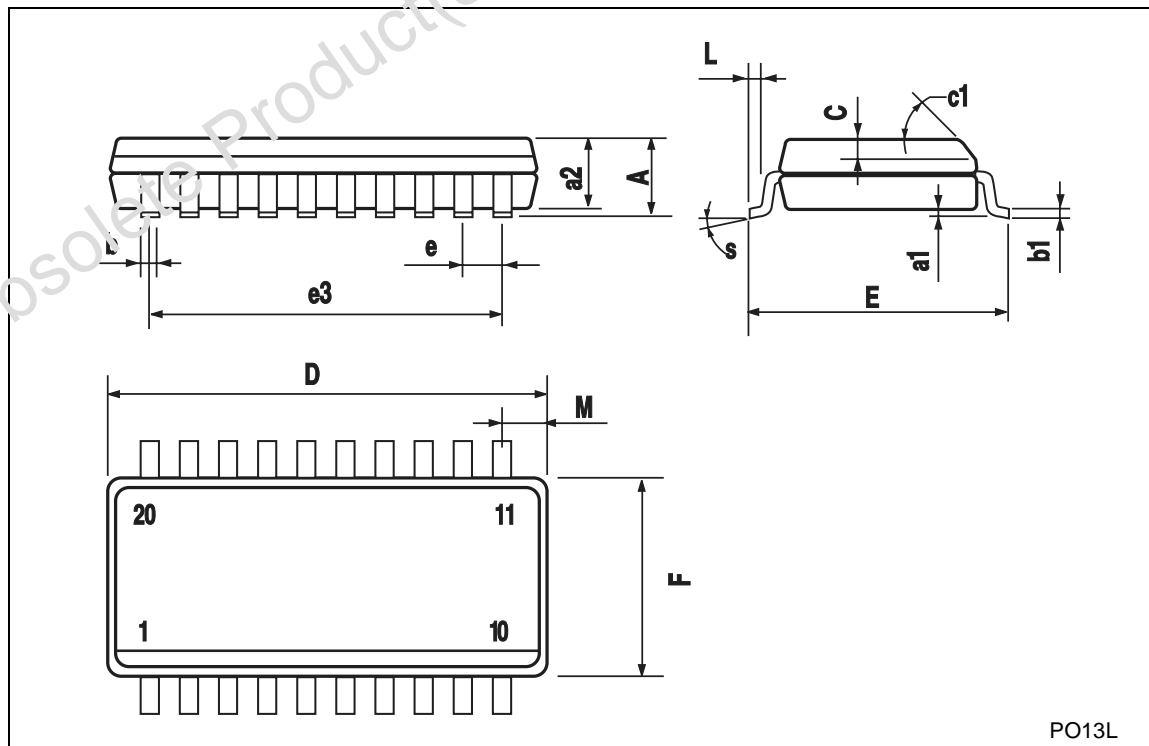

TSSOP20 MECHANICAL DATA

| DIM. | mm. | | | inch | | |
|------|------|----------|------|-------|------------|--------|
| | MIN. | TYP | MAX. | MIN. | TYP. | MAX. |
| A | | | 1.2 | | | 0.047 |
| A1 | 0.05 | | 0.15 | 0.002 | 0.004 | 0.006 |
| A2 | 0.8 | 1 | 1.05 | 0.031 | 0.039 | 0.041 |
| b | 0.19 | | 0.30 | 0.007 | | 0.012 |
| c | 0.09 | | 0.20 | 0.004 | | 0.0089 |
| D | 6.4 | 6.5 | 6.6 | 0.252 | 0.256 | 0.260 |
| E | 6.2 | 6.4 | 6.6 | 0.244 | 0.252 | 0.260 |
| E1 | 4.3 | 4.4 | 4.48 | 0.169 | 0.173 | 0.176 |
| e | | 0.65 BSC | | | 0.0256 BSC | |
| K | 0° | | 8° | 0° | | 8° |
| L | 0.45 | 0.60 | 0.75 | 0.018 | 0.024 | 0.030 |

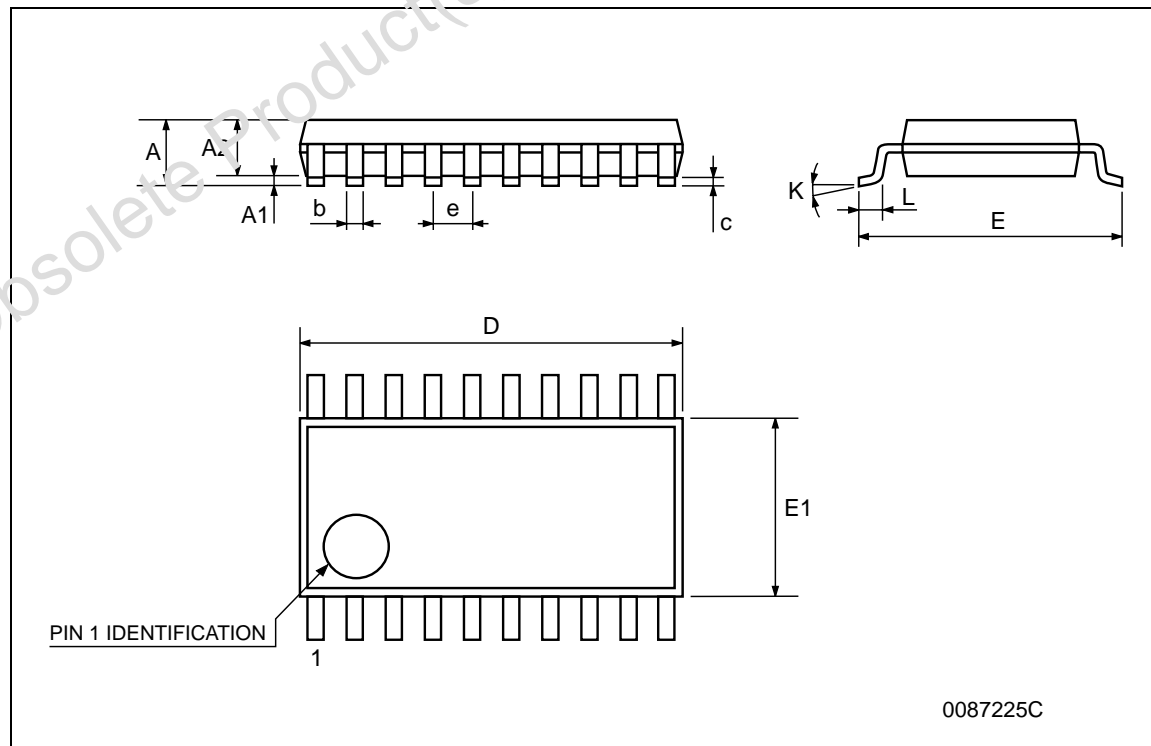

Obsolete Product(s) - Obsolete Product(s)

Information furnished is believed to be accurate and reliable. However, STMicroelectronics assumes no responsibility for the consequences of use of such information nor for any infringement of patents or other rights of third parties which may result from its use. No license is granted by implication or otherwise under any patent or patent rights of STMicroelectronics. Specifications mentioned in this publication are subject to change without notice. This publication supersedes and replaces all information previously supplied. STMicroelectronics products are not authorized for use as critical components in life support devices or systems without express written approval of STMicroelectronics.

© The ST logo is a registered trademark of STMicroelectronics

© 2001 STMicroelectronics - Printed in Italy - All Rights Reserved
STMicroelectronics GROUP OF COMPANIES

Australia - Brazil - China - Finland - France - Germany - Hong Kong - India - Italy - Japan - Malaysia - Malta - Morocco
Singapore - Spain - Sweden - Switzerland - United Kingdom

© <http://www.st.com>

