

74HC366; 74HCT366

Hex buffer/line driver; 3-state; inverting

Rev. 4 — 4 September 2012

Product data sheet

1. General description

The 74HC366; 74HCT366 is a hex inverter/line driver with 3-state outputs controlled by the output enable inputs ($\overline{OE}1$). A HIGH on $\overline{OE}n$ causes the outputs to assume a high impedance OFF-state. Inputs include clamp diodes. This enables the use of current limiting resistors to interface inputs to voltages in excess of V_{CC} .

The 74HC366; 74HCT366 is functionally identical to:

- 74HC365; 74HCT365, but has inverted outputs

2. Features and benefits

- Inverting outputs
- Input levels:
 - ◆ For 74HC366: CMOS level
 - ◆ For 74HC366: TTL level
- Complies with JEDEC standard no. 7A
- ESD protection:
 - ◆ HBM EIA/JESD22-A114-F exceeds 2000 V
 - ◆ MM EIA/JESD22-A115-A exceeds 200 V
- Specified from $-40\text{ }^{\circ}\text{C}$ to $+85\text{ }^{\circ}\text{C}$ and from $-40\text{ }^{\circ}\text{C}$ to $+125\text{ }^{\circ}\text{C}$
- Multiple package options



3. Ordering information

Table 1. Ordering information

Type number	Package			Version
	Temperature range	Name	Description	
74HC366				
74HC366D	-40 °C to +125 °C	SO16	plastic small outline package; 16 leads; body width 3.9 mm	SOT109-1
74HC366N	-40 °C to +125 °C	DIP16	plastic dual in-line package; 16 leads (300 mil); long body	SOT38-1
74HC366PW	-40 °C to +125 °C	TSSOP16	plastic thin shrink small outline package; 16 leads; body width 4.4 mm	SOT403-1
74HCT366				
74HCT366D	-40 °C to +125 °C	SO16	plastic small outline package; 16 leads; body width 3.9 mm	SOT109-1
74HCT366DB	-40 °C to +125 °C	SSOP16	plastic shrink small outline package; 16 leads; body width 5.3 mm	SOT338-1
74HCT366N	-40 °C to +125 °C	DIP16	plastic dual in-line package; 16 leads (300 mil); long body	SOT38-1
74HCT366PW	-40 °C to +125 °C	TSSOP16	plastic thin shrink small outline package; 16 leads; body width 4.4 mm	SOT403-1

4. Functional diagram

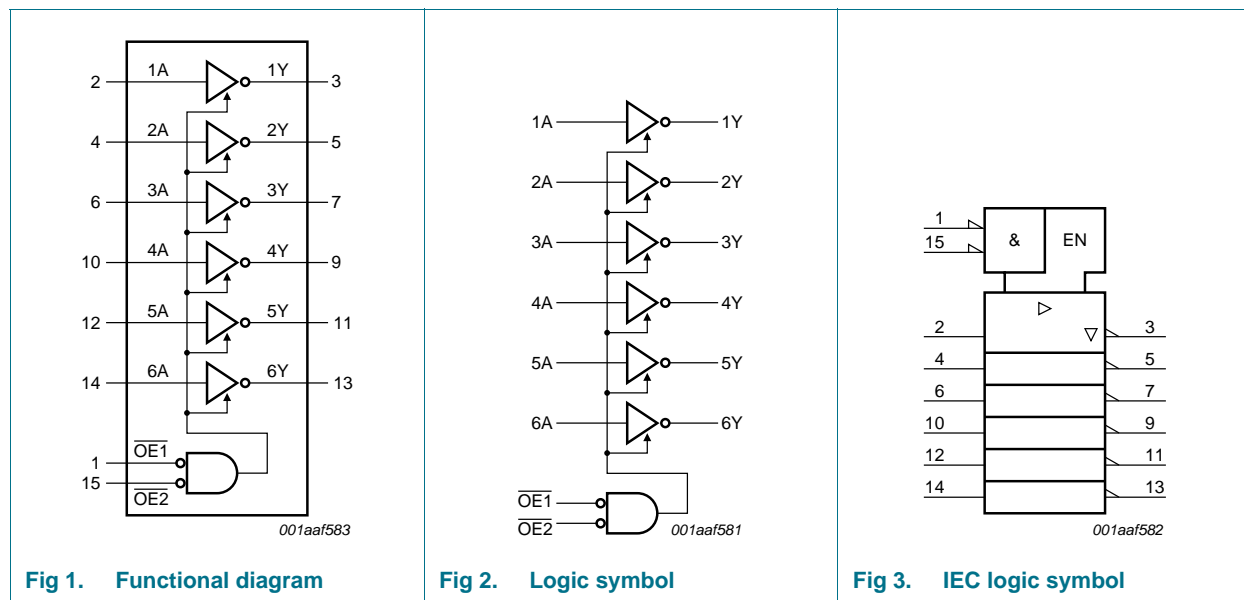

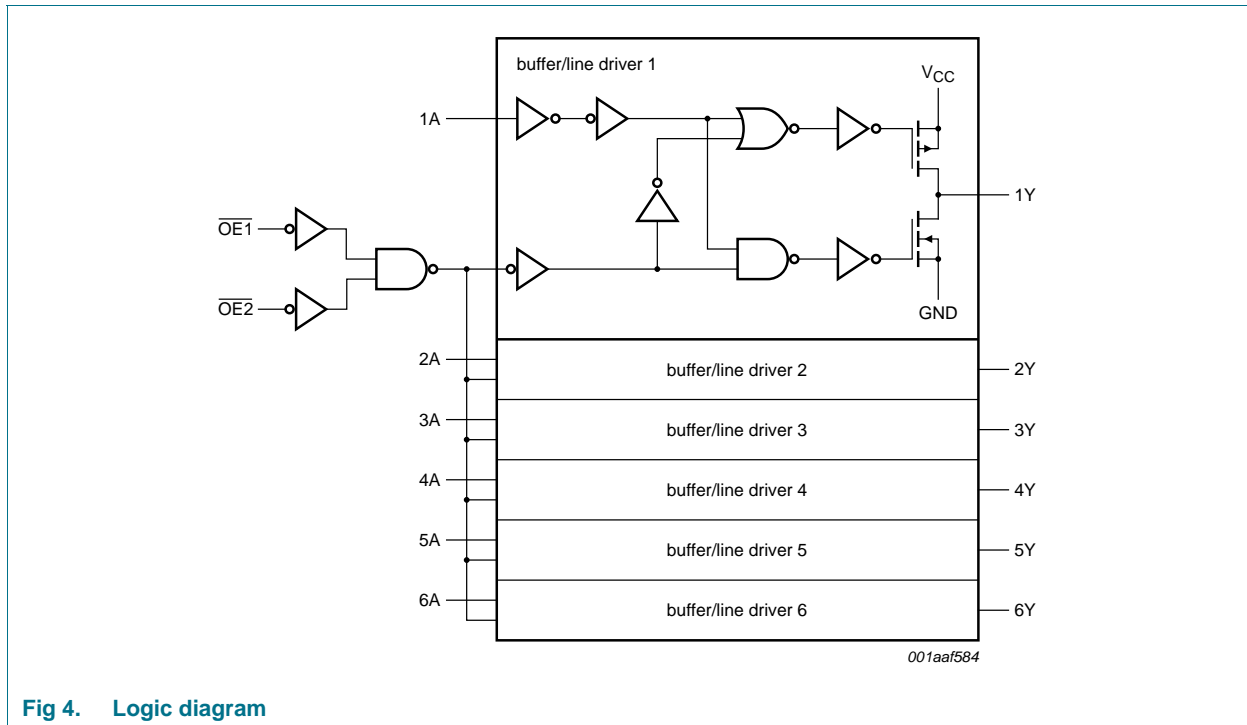

Fig 4. Logic diagram

5. Pinning information

5.1 Pinning

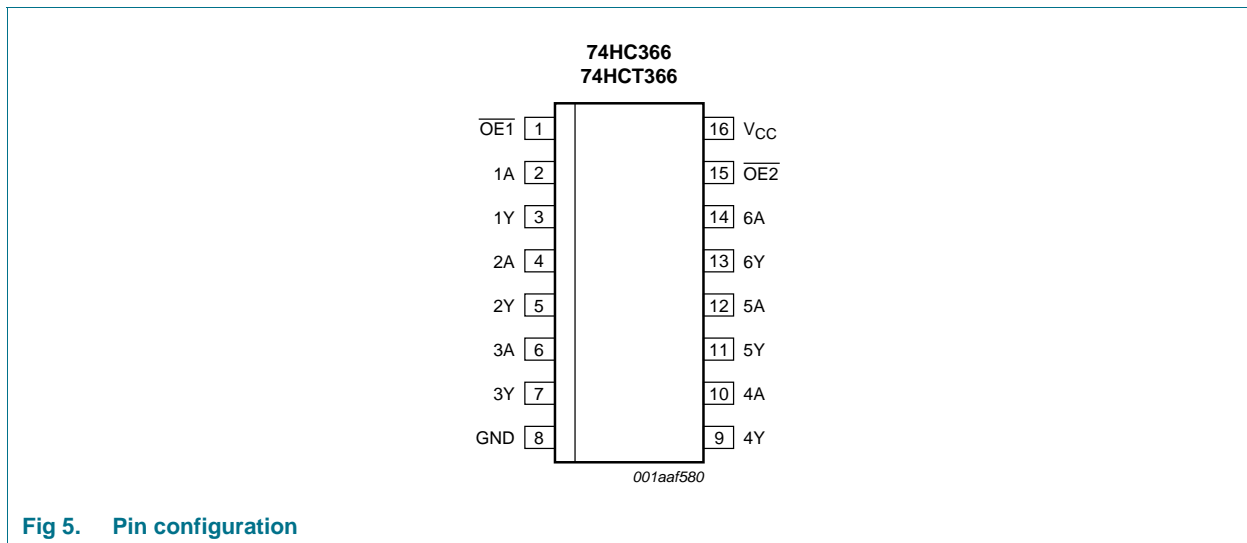

Fig 5. Pin configuration

5.2 Pin description

Table 2. Pin description

Symbol	Pin	Description
$\overline{\text{OE1}}$	1	output enable input 1 (active LOW)
1A	2	data input 1
1Y	3	data output 1
2A	4	data input 2
2Y	5	data output 2
3A	6	data input 3
3Y	7	data output 3
GND	8	ground (0 V)
4Y	9	data output 4
4A	10	data input 4
5Y	11	data output 5
5A	12	data input 5
6Y	13	data output 6
6A	14	data input 6
$\overline{\text{OE2}}$	15	output enable input 2 (active LOW)
V _{CC}	16	supply voltage

6. Functional description

Table 3. Function table^[1]

Control		Input		Output
$\overline{\text{OE1}}$	$\overline{\text{OE2}}$	nA	nA	nY
L	L	L	L	H
L	L	L	H	L
X	H	X	X	Z
H	X	X	X	Z

- [1] H = HIGH voltage level;
 L = LOW voltage level;
 X = don't care;
 Z = high-impedance OFF-state.

7. Limiting values

Table 4. Limiting values

In accordance with the Absolute Maximum Rating System (IEC 60134). Voltages are referenced to GND (ground = 0 V).

Symbol	Parameter	Conditions	Min	Max	Unit	
V_{CC}	supply voltage		-0.5	+7	V	
I_{IK}	input clamping current	$V_I < -0.5\text{ V}$ or $V_I > V_{CC} + 0.5\text{ V}$	-	± 20	mA	
I_{OK}	output clamping current	$V_O < -0.5\text{ V}$ or $V_O > V_{CC} + 0.5\text{ V}$	-	± 20	mA	
I_O	output current	$V_O = -0.5\text{ V}$ to $(V_{CC} + 0.5\text{ V})$	-	± 35	mA	
I_{CC}	supply current		-	70	mA	
I_{GND}	ground current		-	-70	mA	
T_{stg}	storage temperature		-65	+150	°C	
P_{tot}	total power dissipation	DIP16 package	[1]	-	750	mW
		SO16 package	[2]	-	500	mW
		SSOP16 package	[3]	-	500	mW
		TSSOP16 package	[3]	-	500	mW

[1] For DIP16 packages: P_{tot} derates linearly with 12 mW/K above 70 °C.

[2] For SO16 packages: P_{tot} derates linearly with 8 mW/K above 70 °C.

[3] For SSOP16 and TSSOP16 packages: P_{tot} derates linearly with 5.5 mW/K above 60 °C.

8. Recommended operating conditions

Table 5. Recommended operating conditions

Voltages are referenced to GND (ground = 0 V)

Symbol	Parameter	Conditions	74HC366			74HCT366			Unit
			Min	Typ	Max	Min	Typ	Max	
V_{CC}	supply voltage		2.0	5.0	6.0	4.5	5.0	5.5	V
V_I	input voltage		0	-	V_{CC}	0	-	V_{CC}	V
V_O	output voltage		0	-	V_{CC}	0	-	V_{CC}	V
T_{amb}	ambient temperature		-40	+25	+125	-40	+25	+125	°C
$\Delta t/\Delta V$	input transition rise and fall rate	$V_{CC} = 2.0\text{ V}$	-	-	625	-	-	-	ns/V
		$V_{CC} = 4.5\text{ V}$	-	1.67	139	-	1.67	139	ns/V
		$V_{CC} = 6.0\text{ V}$	-	-	83	-	-	-	ns/V

9. Static characteristics

Table 6. Static characteristics 74HC366
At recommended operating conditions; voltages are referenced to GND (ground = 0 V).

Symbol	Parameter	Conditions	Min	Typ	Max	Unit
T_{amb} = 25 °C						
V _{IH}	HIGH-level input voltage	V _{CC} = 2.0 V	1.5	1.2	-	V
		V _{CC} = 4.5 V	3.15	2.4	-	V
		V _{CC} = 6.0 V	4.2	3.2	-	V
V _{IL}	LOW-level input voltage	V _{CC} = 2.0 V	-	0.8	0.5	V
		V _{CC} = 4.5 V	-	2.1	1.35	V
		V _{CC} = 6.0 V	-	2.8	1.8	V
V _{OH}	HIGH-level output voltage	V _I = V _{IH} or V _{IL}	-	-	-	
		I _O = -20 μA; V _{CC} = 2.0 V	1.9	2.0	-	V
		I _O = -20 μA; V _{CC} = 4.5 V	4.4	4.5	-	V
		I _O = -20 μA; V _{CC} = 6.0 V	5.9	6.0	-	V
		I _O = -6.0 mA; V _{CC} = 4.5 V	3.98	4.32	-	V
		I _O = -7.8 mA; V _{CC} = 6.0 V	5.48	5.81	-	V
V _{OL}	LOW-level output voltage	V _I = V _{IH} or V _{IL}	-	-	-	
		I _O = 20 μA; V _{CC} = 2.0 V	-	0	0.1	V
		I _O = 20 μA; V _{CC} = 4.5 V	-	0	0.1	V
		I _O = 20 μA; V _{CC} = 6.0 V	-	0	0.1	V
		I _O = 6.0 mA; V _{CC} = 4.5 V	-	0.15	0.26	V
		I _O = 7.8 mA; V _{CC} = 6.0 V	-	0.16	0.26	V
I _I	input leakage current	V _I = V _{CC} or GND; V _{CC} = 6.0 V	-	-	±0.1	μA
I _{OZ}	OFF-state output current	V _I = V _{IH} or V _{IL} ; V _O = V _{CC} or GND; V _{CC} = 6.0 V	-	-	±0.5	μA
I _{CC}	supply current	V _I = V _{CC} or GND; I _O = 0 A; V _{CC} = 6.0 V	-	-	8.0	μA
C _I	input capacitance		-	3.5	-	pF
T_{amb} = -40 °C to +85 °C						
V _{IH}	HIGH-level input voltage	V _{CC} = 2.0 V	1.5	-	-	V
		V _{CC} = 4.5 V	3.15	-	-	V
		V _{CC} = 6.0 V	4.2	-	-	V
V _{IL}	LOW-level input voltage	V _{CC} = 2.0 V	-	-	0.5	V
		V _{CC} = 4.5 V	-	-	1.35	V
		V _{CC} = 6.0 V	-	-	1.8	V
V _{OH}	HIGH-level output voltage	V _I = V _{IH} or V _{IL}	-	-	-	
		I _O = -20 μA; V _{CC} = 2.0 V	1.9	-	-	V
		I _O = -20 μA; V _{CC} = 4.5 V	4.4	-	-	V
		I _O = -20 μA; V _{CC} = 6.0 V	5.9	-	-	V
		I _O = -6.0 mA; V _{CC} = 4.5 V	3.84	-	-	V
		I _O = -7.8 mA; V _{CC} = 6.0 V	5.34	-	-	V

Table 6. Static characteristics 74HC366 ...continued

At recommended operating conditions; voltages are referenced to GND (ground = 0 V).

Symbol	Parameter	Conditions	Min	Typ	Max	Unit
V _{OL}	LOW-level output voltage	V _I = V _{IH} or V _{IL}				
		I _O = 20 μA; V _{CC} = 2.0 V	-	-	0.1	V
		I _O = 20 μA; V _{CC} = 4.5 V	-	-	0.1	V
		I _O = 20 μA; V _{CC} = 6.0 V	-	-	0.1	V
		I _O = 6.0 mA; V _{CC} = 4.5 V	-	-	0.33	V
		I _O = 7.8 mA; V _{CC} = 6.0 V	-	-	0.33	V
I _I	input leakage current	V _I = V _{CC} or GND; V _{CC} = 6.0 V;	-	-	±1.0	μA
I _{OZ}	OFF-state output current	V _I = V _{IH} or V _{IL} ; V _O = V _{CC} or GND; V _{CC} = 6.0 V	-	-	±5.0	μA
I _{CC}	supply current	V _I = V _{CC} or GND; I _O = 0 A; V _{CC} = 6.0 V	-	-	80	μA
T_{amb} = -40 °C to +125 °C						
V _{IH}	HIGH-level input voltage	V _{CC} = 2.0 V	1.5	-	-	V
		V _{CC} = 4.5 V	3.15	-	-	V
		V _{CC} = 6.0 V	4.2	-	-	V
V _{IL}	LOW-level input voltage	V _{CC} = 2.0 V	-	-	0.5	V
		V _{CC} = 4.5 V	-	-	1.35	V
		V _{CC} = 6.0 V	-	-	1.8	V
V _{OH}	HIGH-level output voltage	V _I = V _{IH} or V _{IL}				
		I _O = -20 μA; V _{CC} = 2.0 V	1.9	-	-	V
		I _O = -20 μA; V _{CC} = 4.5 V	4.4	-	-	V
		I _O = -20 μA; V _{CC} = 6.0 V	5.9	-	-	V
		I _O = -6.0 mA; V _{CC} = 4.5 V	3.7	-	-	V
		I _O = -7.8 mA; V _{CC} = 6.0 V	5.2	-	-	V
V _{OL}	LOW-level output voltage	V _I = V _{IH} or V _{IL}				
		I _O = 20 μA; V _{CC} = 2.0 V	-	-	0.1	V
		I _O = 20 μA; V _{CC} = 4.5 V	-	-	0.1	V
		I _O = 20 μA; V _{CC} = 6.0 V	-	-	0.1	V
		I _O = 6.0 mA; V _{CC} = 4.5 V	-	-	0.4	V
		I _O = 7.8 mA; V _{CC} = 6.0 V	-	-	0.4	V
I _I	input leakage current	V _I = V _{CC} or GND; V _{CC} = 6.0 V	-	-	±1.0	μA
I _{OZ}	OFF-state output current	V _I = V _{IH} or V _{IL} ; V _O = V _{CC} or GND; V _{CC} = 6.0 V	-	-	±10.0	μA
I _{CC}	supply current	V _I = V _{CC} or GND; I _O = 0 A; V _{CC} = 6.0 V	-	-	160	μA

Table 7. Static characteristics 74HCT366

At recommended operating conditions; voltages are referenced to GND (ground = 0 V).

Symbol	Parameter	Conditions	Min	Typ	Max	Unit
T_{amb} = 25 °C						
V _{IH}	HIGH-level input voltage	V _{CC} = 4.5 V to 5.5 V	2.0	1.6	-	V
V _{IL}	LOW-level input voltage	V _{CC} = 4.5 V to 5.5 V	-	1.2	0.8	V
V _{OH}	HIGH-level output voltage	V _I = V _{IH} or V _{IL} ; V _{CC} = 4.5 V				
		I _O = -20 μA	4.4	4.5	-	V
		I _O = -6.0 mA	3.98	4.32	-	V

Table 7. Static characteristics 74HCT366 ...continued

At recommended operating conditions; voltages are referenced to GND (ground = 0 V).

Symbol	Parameter	Conditions	Min	Typ	Max	Unit
V _{OL}	LOW-level output voltage	V _I = V _{IH} or V _{IL} ; V _{CC} = 4.5 V				
		I _O = 20 μA	-	0	0.1	V
		I _O = 6.0 mA	-	0.16	0.26	V
I _I	input leakage current	V _I = V _{CC} or GND; V _{CC} = 5.5 V	-	-	±0.1	μA
I _{OZ}	OFF-state output current	V _I = V _{IH} or V _{IL} ; V _O = V _{CC} or GND per input pin; other inputs at GND or V _{CC} ; I _O = 0 A; V _{CC} = 5.5 V	-	-	±0.5	μA
I _{CC}	supply current	V _I = V _{CC} or GND; I _O = 0 A; V _{CC} = 5.5 V	-	-	8.0	μA
ΔI _{CC}	additional supply current	V _I = V _{CC} - 2.1 V; other inputs at V _{CC} or GND; I _O = 0 A				
		pins nA	-	100	360	μA
		pin $\overline{OE1}$	-	100	360	μA
		pin $\overline{OE2}$	-	90	320	μA
C _I	input capacitance		-	3.5	-	pF
T_{amb} = -40 °C to +85 °C						
V _{IH}	HIGH-level input voltage	V _{CC} = 4.5 V to 5.5 V	2.0	-	-	V
V _{IL}	LOW-level input voltage	V _{CC} = 4.5 V to 5.5 V	-	-	0.8	V
V _{OH}	HIGH-level output voltage	V _I = V _{IH} or V _{IL} ; V _{CC} = 4.5 V				
		I _O = -20 μA	4.4	-	-	V
		I _O = -6.0 mA	3.84	-	-	V
V _{OL}	LOW-level output voltage	V _I = V _{IH} or V _{IL} ; V _{CC} = 4.5 V				
		I _O = 20 μA	-	-	0.1	V
		I _O = 6.0 mA	-	-	0.33	V
I _I	input leakage current	V _I = V _{CC} or GND; V _{CC} = 5.5 V	-	-	±1.0	μA
I _{OZ}	OFF-state output current	V _I = V _{IH} or V _{IL} ; V _O = V _{CC} or GND per input pin; other inputs at GND or V _{CC} ; I _O = 0 A; V _{CC} = 5.5 V			±5.0	μA
I _{CC}	supply current	V _I = V _{CC} or GND; I _O = 0 A; V _{CC} = 5.5 V	-	-	80	μA
ΔI _{CC}	additional supply current	V _I = V _{CC} - 2.1 V; other inputs at V _{CC} or GND; I _O = 0 A				
		pins nA	-	-	450	μA
		pin $\overline{OE1}$	-	-	450	μA
		pin $\overline{OE2}$	-	-	400	μA
T_{amb} = -40 °C to +125 °C						
V _{IH}	HIGH-level input voltage	V _{CC} = 4.5 V to 5.5 V	2.0	-	-	V
V _{IL}	LOW-level input voltage	V _{CC} = 4.5 V to 5.5 V	-	-	0.8	V
V _{OH}	HIGH-level output voltage	V _I = V _{IH} or V _{IL} ; V _{CC} = 4.5 V				
		I _O = -20 μA	4.4	-	-	V
		I _O = -6.0 mA	3.7	-	-	V
V _{OL}	LOW-level output voltage	V _I = V _{IH} or V _{IL} ; V _{CC} = 4.5 V				
		I _O = 20 μA	-	-	0.1	V
		I _O = 6.0 mA	-	-	0.4	V
I _I	input leakage current	V _I = V _{CC} or GND; V _{CC} = 5.5 V	-	-	±1.0	μA
I _{OZ}	OFF-state output current	V _I = V _{IH} or V _{IL} ; V _O = V _{CC} or GND per input pin; other inputs at GND or V _{CC} ; I _O = 0 A; V _{CC} = 5.5 V	-	-	±10.0	μA

Table 7. Static characteristics 74HCT366 ...continued

At recommended operating conditions; voltages are referenced to GND (ground = 0 V).

Symbol	Parameter	Conditions	Min	Typ	Max	Unit
I_{CC}	supply current	$V_I = V_{CC}$ or GND; $I_O = 0$ A; $V_{CC} = 5.5$ V	-	-	160	μ A
ΔI_{CC}	additional supply current	$V_I = V_{CC} - 2.1$ V; other inputs at V_{CC} or GND; $I_O = 0$ A				
		pins nA	-	-	490	μ A
		pin OE1	-	-	490	μ A
		pin OE2	-	-	441	μ A

10. Dynamic characteristics

Table 8. Dynamic characteristics 74HC366Voltages are referenced to GND (ground = 0 V); $C_L = 50$ pF unless otherwise specified; see test circuit [Figure 8](#).

Symbol	Parameter	Conditions	Min	Typ	Max	Unit
$T_{amb} = 25$ °C						
t_{pd}	propagation delay	nA to nY; see Figure 6	[1]			
		$V_{CC} = 2.0$ V	-	33	100	ns
		$V_{CC} = 4.5$ V	-	12	20	ns
		$V_{CC} = 5$ V; $C_L = 15$ pF	-	10	-	ns
		$V_{CC} = 6.0$ V	-	10	17	ns
t_{en}	enable time	OEn to nY; see Figure 7	[2]			
		$V_{CC} = 2.0$ V	-	44	150	ns
		$V_{CC} = 4.5$ V	-	16	30	ns
		$V_{CC} = 6.0$ V	-	13	26	ns
t_{dis}	disable time	OEn to nY; see Figure 7	[3]			
		$V_{CC} = 2.0$ V	-	55	150	ns
		$V_{CC} = 4.5$ V	-	20	30	ns
		$V_{CC} = 6.0$ V	-	16	26	ns
t_t	transition time	see Figure 6	[4]			
		$V_{CC} = 2.0$ V	-	14	60	ns
		$V_{CC} = 4.5$ V	-	5	12	ns
		$V_{CC} = 6.0$ V	-	4	10	ns
C_{PD}	power dissipation capacitance	per buffer; $V_I =$ GND to V_{CC}	[5]	-	30	pF
$T_{amb} = -40$ °C to $+85$ °C						
t_{pd}	propagation delay	nA to nY; see Figure 6	[1]			
		$V_{CC} = 2.0$ V	-	-	125	ns
		$V_{CC} = 4.5$ V	-	-	25	ns
		$V_{CC} = 6.0$ V	-	-	21	ns
t_{en}	enable time	OEn to nY; see Figure 7	[2]			
		$V_{CC} = 2.0$ V	-	-	190	ns
		$V_{CC} = 4.5$ V	-	-	38	ns
		$V_{CC} = 6.0$ V	-	-	33	ns

Table 8. Dynamic characteristics 74HC366 ...continued

Voltages are referenced to GND (ground = 0 V); $C_L = 50$ pF unless otherwise specified; see test circuit [Figure 8](#).

Symbol	Parameter	Conditions	Min	Typ	Max	Unit
t_{dis}	disable time	\overline{OEn} to nY; see Figure 7	[3]			
		$V_{CC} = 2.0$ V	-	-	190	ns
		$V_{CC} = 4.5$ V	-	-	38	ns
		$V_{CC} = 6.0$ V	-	-	33	ns
t_t	transition time	see Figure 6	[4]			
		$V_{CC} = 2.0$ V	-	-	75	ns
		$V_{CC} = 4.5$ V	-	-	15	ns
		$V_{CC} = 6.0$ V	-	-	13	ns
$T_{amb} = -40$ °C to $+125$ °C						
t_{pd}	propagation delay	nA to nY; see Figure 6	[1]			
		$V_{CC} = 2.0$ V	-	-	150	ns
		$V_{CC} = 4.5$ V	-	-	30	ns
		$V_{CC} = 6.0$ V	-	-	26	ns
t_{en}	enable time	\overline{OEn} to nY; see Figure 7	[2]			
		$V_{CC} = 2.0$ V	-	-	225	ns
		$V_{CC} = 4.5$ V	-	-	45	ns
		$V_{CC} = 6.0$ V	-	-	38	ns
t_{dis}	disable time	\overline{OEn} to nY; see Figure 7	[3]			
		$V_{CC} = 2.0$ V	-	-	225	ns
		$V_{CC} = 4.5$ V	-	-	45	ns
		$V_{CC} = 6.0$ V	-	-	38	ns
t_t	transition time	see Figure 6	[4]			
		$V_{CC} = 2.0$ V	-	-	90	ns
		$V_{CC} = 4.5$ V	-	-	18	ns
		$V_{CC} = 6.0$ V	-	-	15	ns

[1] t_{pd} is the same as t_{PHL} and t_{PLH} .

[2] t_{en} is the same as t_{PZH} and t_{PZL} .

[3] t_{dis} is the same as t_{PHZ} and t_{PLZ} .

[4] t_t is the same as t_{THL} and t_{TLH} .

[5] C_{PD} is used to determine the dynamic power dissipation (P_D in μ W).

$$P_D = C_{PD} \times V_{CC}^2 \times f_i \times N + \sum(C_L \times V_{CC}^2 \times f_o) \text{ where:}$$

f_i = input frequency in MHz;

f_o = output frequency in MHz;

C_L = output load capacitance in pF;

V_{CC} = supply voltage in V;

N = number of inputs switching;

$\sum(C_L \times V_{CC}^2 \times f_o)$ = sum of outputs.

Table 9. Dynamic characteristics 74HCT366

Voltages are referenced to GND (ground = 0 V); $C_L = 50$ pF unless otherwise specified; see test circuit [Figure 8](#).

Symbol	Parameter	Conditions	Min	Typ	Max	Unit
$T_{amb} = 25$ °C						
t_{pd}	propagation delay	nA to nY; see Figure 6	[1]			
		$V_{CC} = 4.5$ V	-	13	24	ns
		$V_{CC} = 5$ V; $C_L = 15$ pF	-	11	-	ns
t_{en}	enable time	\overline{OEn} to nY; $V_{CC} = 4.5$ V; see Figure 7	[2]	-	16	35 ns
t_{dis}	disable time	\overline{OEn} to nY; $V_{CC} = 4.5$ V; see Figure 7	[3]	-	20	35 ns
t_t	transition time	$V_{CC} = 4.5$ V; see Figure 6	[4]	-	5	12 ns
C_{PD}	power dissipation capacitance	per buffer; $V_I = GND$ to $(V_{CC} - 1.5$ V)	[5]	-	30	- pF
$T_{amb} = -40$ °C to $+85$ °C						
t_{pd}	propagation delay	nA to nY; $V_{CC} = 4.5$ V; see Figure 6	[1]	-	-	30 ns
t_{en}	enable time	\overline{OEn} to nY; $V_{CC} = 4.5$ V; see Figure 7	[2]	-	-	44 ns
t_{dis}	disable time	\overline{OEn} to nY; $V_{CC} = 4.5$ V; see Figure 7	[3]	-	-	44 ns
t_t	transition time	$V_{CC} = 4.5$ V; see Figure 6	[4]	-	-	15 ns
$T_{amb} = -40$ °C to $+125$ °C						
t_{pd}	propagation delay	nA to nY; $V_{CC} = 4.5$ V; see Figure 6	[1]	-	-	36 ns
t_{en}	enable time	\overline{OEn} to nY; $V_{CC} = 4.5$ V; see Figure 7	[2]	-	-	53 ns
t_{dis}	disable time	\overline{OEn} to nY; $V_{CC} = 4.5$ V; see Figure 7	[3]	-	-	53 ns
t_t	transition time	$V_{CC} = 4.5$ V; see Figure 6	[4]	-	-	18 ns

[1] t_{pd} is the same as t_{PHL} and t_{PLH} .

[2] t_{en} is the same as t_{PZH} and t_{PZL} .

[3] t_{dis} is the same as t_{PHZ} and t_{PLZ} .

[4] t_t is the same as t_{THL} and t_{TLH} .

[5] C_{PD} is used to determine the dynamic power dissipation (P_D in μ W).

$P_D = C_{PD} \times V_{CC}^2 \times f_i \times N + \sum(C_L \times V_{CC}^2 \times f_o)$ where:

f_i = input frequency in MHz;

f_o = output frequency in MHz;

C_L = output load capacitance in pF;

V_{CC} = supply voltage in V;

N = number of inputs switching;

$\sum(C_L \times V_{CC}^2 \times f_o)$ = sum of outputs.

11. Waveforms

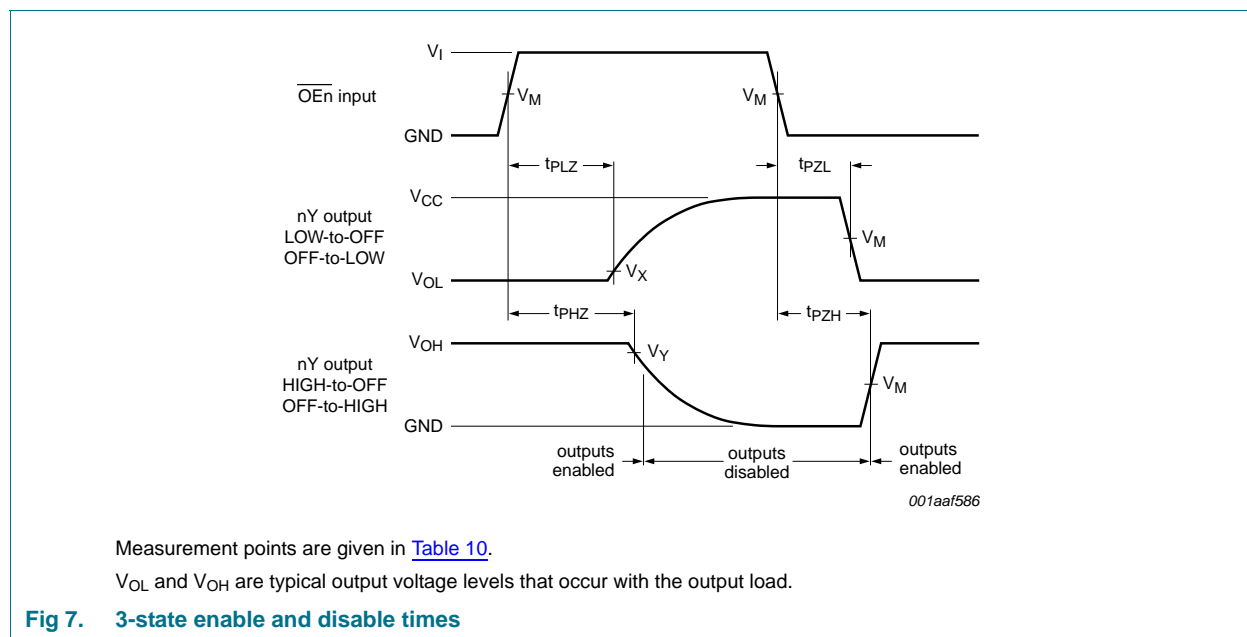
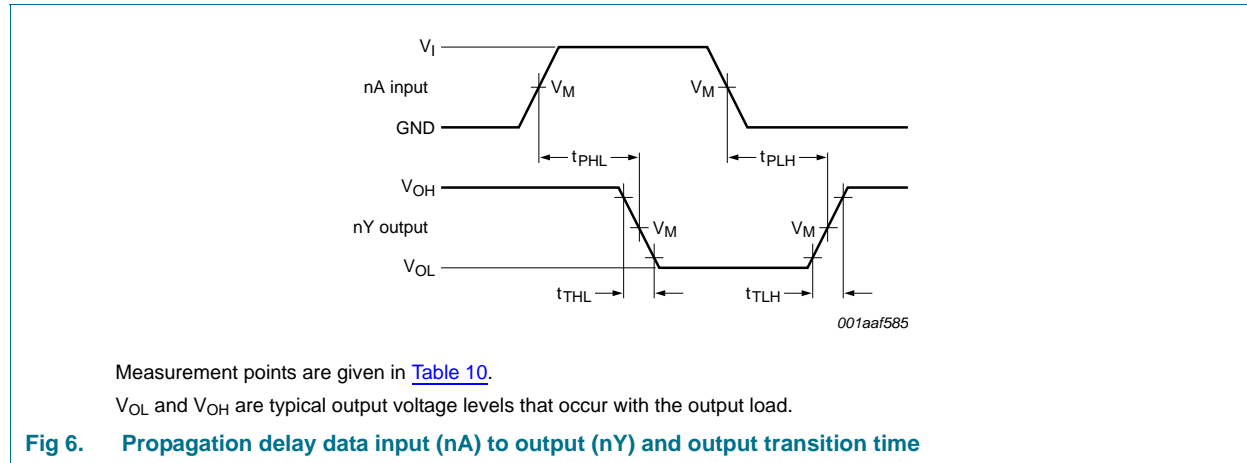

Table 10. Measurement points

Type	Input	Output		
	V_M	V_M	V_X	V_Y
74HC366	$0.5V_{CC}$	$0.5V_{CC}$	$0.1 \times V_{CC}$	$0.9 \times V_{CC}$
74HCT366	1.3 V	1.3 V	$0.1 \times V_{CC}$	$0.9 \times V_{CC}$

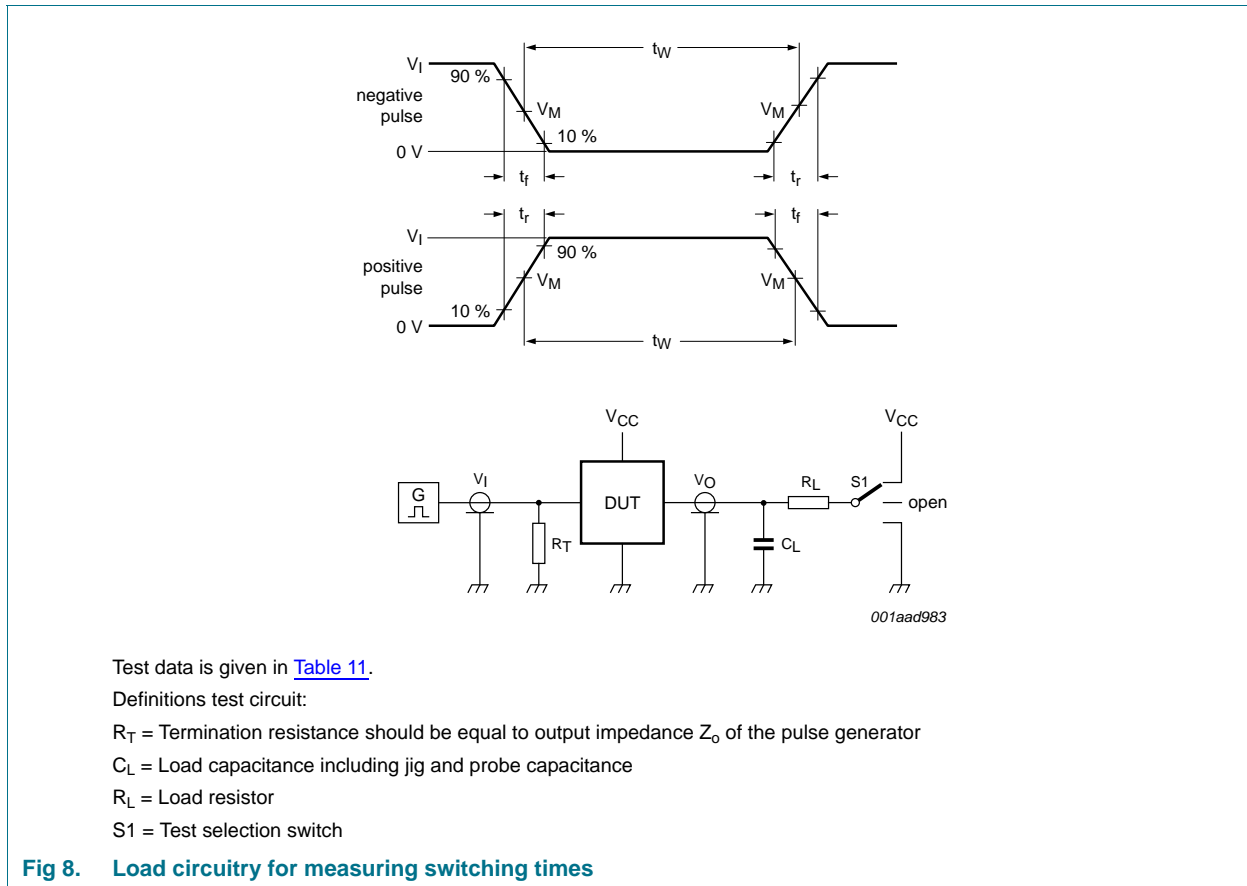

Table 11. Test data

Type	Input		Load		S1 position		
	V_I	t_r, t_f	C_L	R_L	t_{PHL}, t_{PLH}	t_{PZH}, t_{PHZ}	t_{PZL}, t_{PLZ}
74HC366	V_{CC}	6 ns	15 pF, 50 pF	1 k Ω	open	GND	V_{CC}
74HCT366	3 V	6 ns	15 pF, 50 pF	1 k Ω	open	GND	V_{CC}

12. Package outline

SO16: plastic small outline package; 16 leads; body width 3.9 mm

SOT109-1

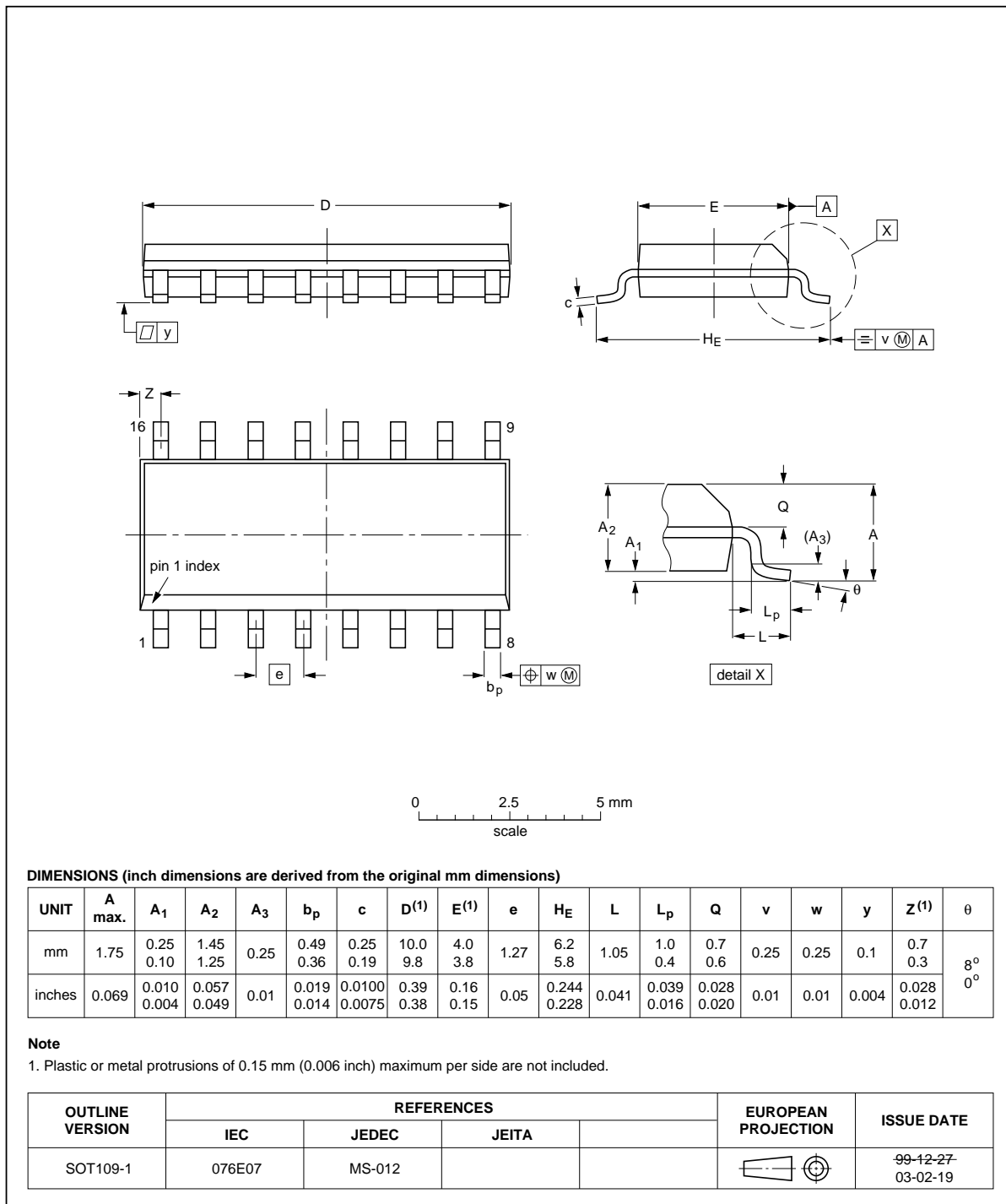

Fig 9. Package outline SOT109-1 (SO16)

SSOP16: plastic shrink small outline package; 16 leads; body width 5.3 mm

SOT338-1

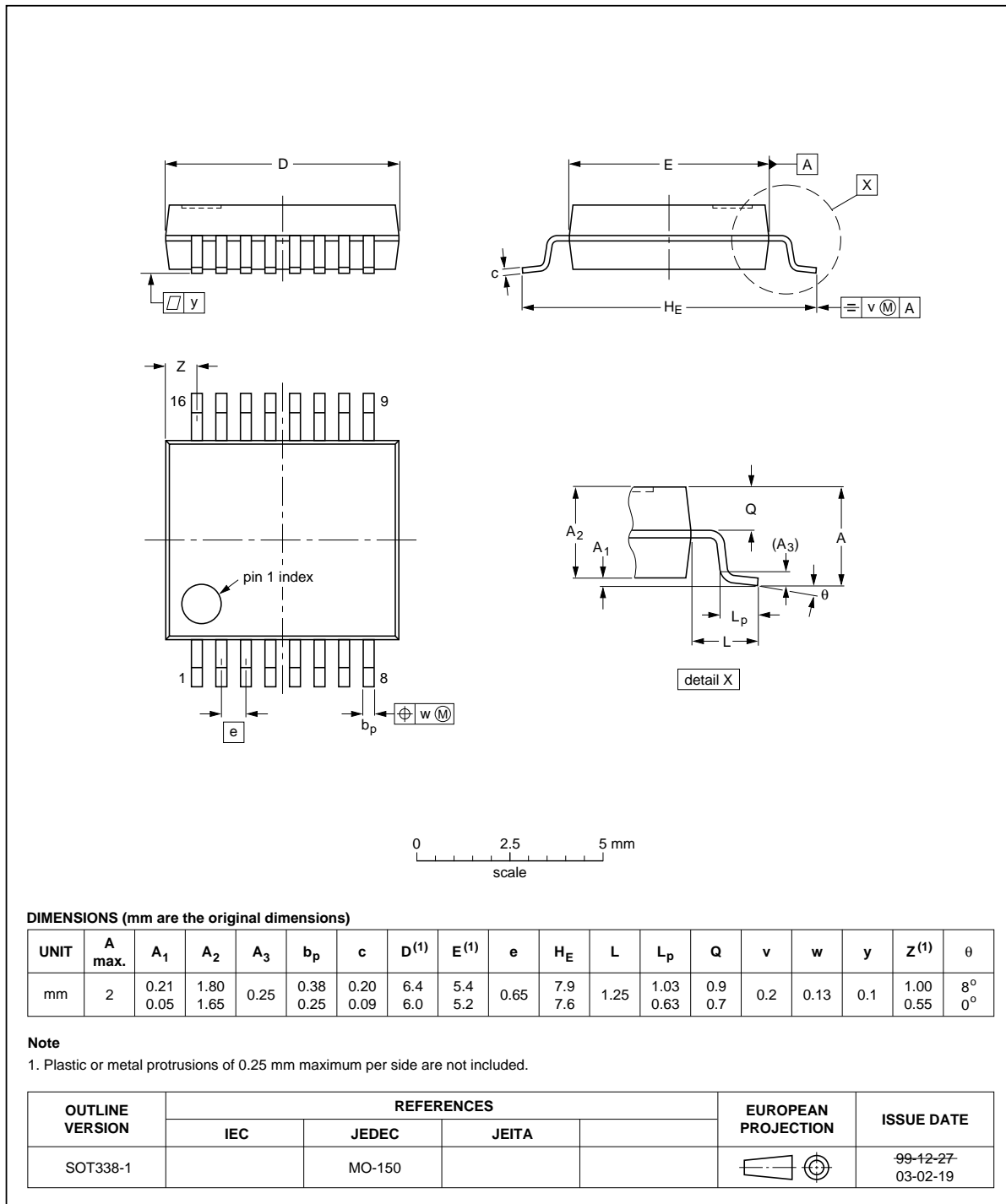

Fig 10. Package outline SOT338-1 (SSOP16)

DIP16: plastic dual in-line package; 16 leads (300 mil); long body

SOT38-1

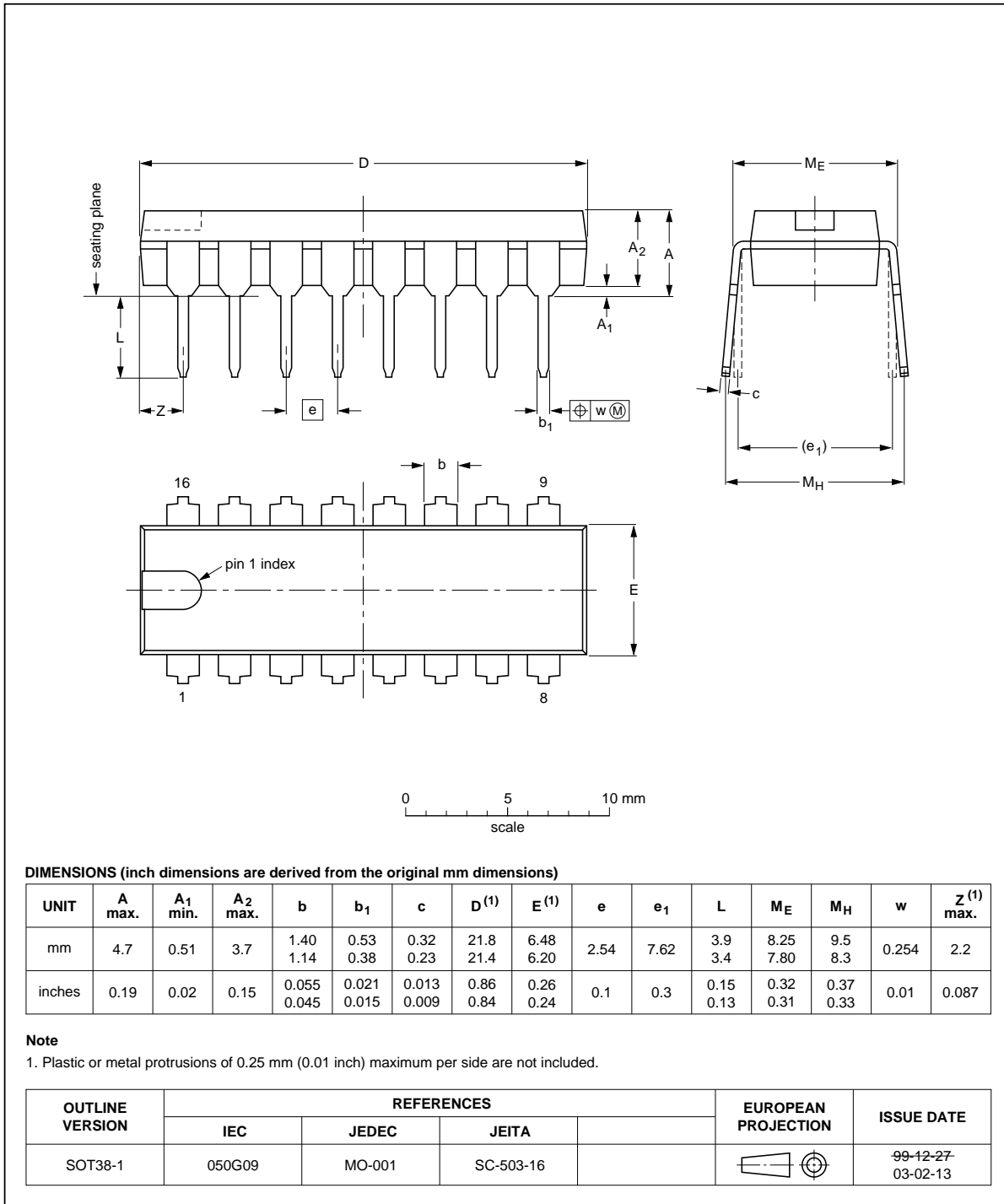

Fig 11. Package outline SOT38-1 (DIP16)

TSSOP16: plastic thin shrink small outline package; 16 leads; body width 4.4 mm

SOT403-1

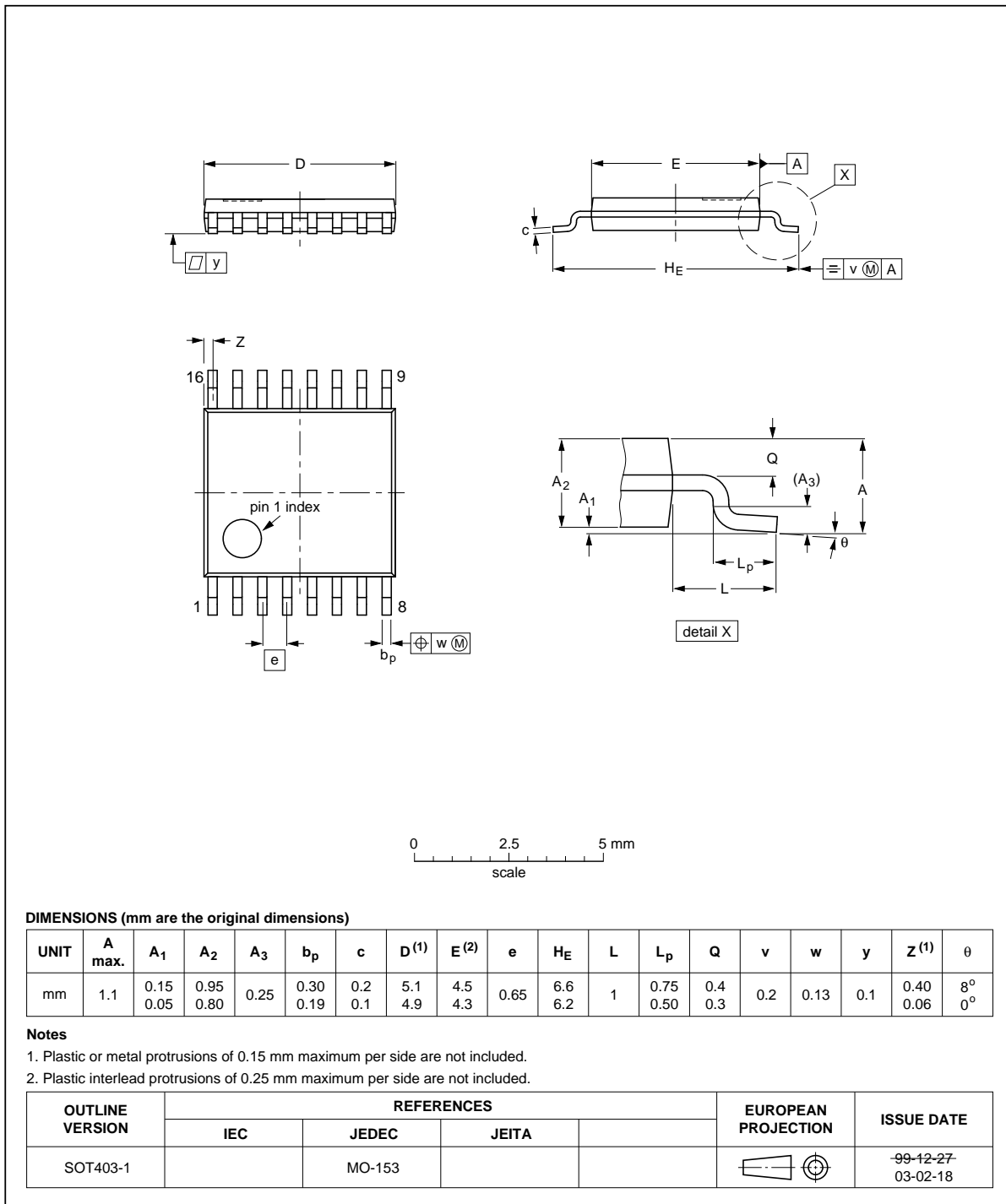

Fig 12. Package outline SOT403-1 (TSSOP16)

13. Abbreviations

Table 12. Abbreviations

Acronym	Description
CMOS	Complementary Metal Oxide Semiconductor
DUT	Device Under Test
ESD	ElectroStatic Discharge
HBM	Human Body Model
LSTTL	Low-power Schottky Transistor-Transistor Logic
MM	Machine Model

14. Revision history

Table 13. Revision history

Document ID	Release date	Data sheet status	Change notice	Supersedes
74HC_HCT366 v.4	20120904	Product data sheet	-	74HC_HCT366 v.3
Modifications:	<ul style="list-style-type: none"> Legal pages updated. 			
74HC_HCT366 v.3	20061121	Product data sheet	-	74HC_HCT366_CNV v.2
74HC_HCT366_CNV v.2	19901201	Product specification	-	-

15. Legal information

15.1 Data sheet status

Document status ^{[1][2]}	Product status ^[3]	Definition
Objective [short] data sheet	Development	This document contains data from the objective specification for product development.
Preliminary [short] data sheet	Qualification	This document contains data from the preliminary specification.
Product [short] data sheet	Production	This document contains the product specification.

[1] Please consult the most recently issued document before initiating or completing a design.

[2] The term 'short data sheet' is explained in section "Definitions".

[3] The product status of device(s) described in this document may have changed since this document was published and may differ in case of multiple devices. The latest product status information is available on the Internet at URL <http://www.nxp.com>.

15.2 Definitions

Draft — The document is a draft version only. The content is still under internal review and subject to formal approval, which may result in modifications or additions. NXP Semiconductors does not give any representations or warranties as to the accuracy or completeness of information included herein and shall have no liability for the consequences of use of such information.

Short data sheet — A short data sheet is an extract from a full data sheet with the same product type number(s) and title. A short data sheet is intended for quick reference only and should not be relied upon to contain detailed and full information. For detailed and full information see the relevant full data sheet, which is available on request via the local NXP Semiconductors sales office. In case of any inconsistency or conflict with the short data sheet, the full data sheet shall prevail.

Product specification — The information and data provided in a Product data sheet shall define the specification of the product as agreed between NXP Semiconductors and its customer, unless NXP Semiconductors and customer have explicitly agreed otherwise in writing. In no event however, shall an agreement be valid in which the NXP Semiconductors product is deemed to offer functions and qualities beyond those described in the Product data sheet.

15.3 Disclaimers

Limited warranty and liability — Information in this document is believed to be accurate and reliable. However, NXP Semiconductors does not give any representations or warranties, expressed or implied, as to the accuracy or completeness of such information and shall have no liability for the consequences of use of such information. NXP Semiconductors takes no responsibility for the content in this document if provided by an information source outside of NXP Semiconductors.

In no event shall NXP Semiconductors be liable for any indirect, incidental, punitive, special or consequential damages (including - without limitation - lost profits, lost savings, business interruption, costs related to the removal or replacement of any products or rework charges) whether or not such damages are based on tort (including negligence), warranty, breach of contract or any other legal theory.

Notwithstanding any damages that customer might incur for any reason whatsoever, NXP Semiconductors' aggregate and cumulative liability towards customer for the products described herein shall be limited in accordance with the *Terms and conditions of commercial sale* of NXP Semiconductors.

Right to make changes — NXP Semiconductors reserves the right to make changes to information published in this document, including without limitation specifications and product descriptions, at any time and without notice. This document supersedes and replaces all information supplied prior to the publication hereof.

Suitability for use — NXP Semiconductors products are not designed, authorized or warranted to be suitable for use in life support, life-critical or safety-critical systems or equipment, nor in applications where failure or malfunction of an NXP Semiconductors product can reasonably be expected to result in personal injury, death or severe property or environmental damage. NXP Semiconductors and its suppliers accept no liability for inclusion and/or use of NXP Semiconductors products in such equipment or applications and therefore such inclusion and/or use is at the customer's own risk.

Applications — Applications that are described herein for any of these products are for illustrative purposes only. NXP Semiconductors makes no representation or warranty that such applications will be suitable for the specified use without further testing or modification.

Customers are responsible for the design and operation of their applications and products using NXP Semiconductors products, and NXP Semiconductors accepts no liability for any assistance with applications or customer product design. It is customer's sole responsibility to determine whether the NXP Semiconductors product is suitable and fit for the customer's applications and products planned, as well as for the planned application and use of customer's third party customer(s). Customers should provide appropriate design and operating safeguards to minimize the risks associated with their applications and products.

NXP Semiconductors does not accept any liability related to any default, damage, costs or problem which is based on any weakness or default in the customer's applications or products, or the application or use by customer's third party customer(s). Customer is responsible for doing all necessary testing for the customer's applications and products using NXP Semiconductors products in order to avoid a default of the applications and the products or of the application or use by customer's third party customer(s). NXP does not accept any liability in this respect.

Limiting values — Stress above one or more limiting values (as defined in the Absolute Maximum Ratings System of IEC 60134) will cause permanent damage to the device. Limiting values are stress ratings only and (proper) operation of the device at these or any other conditions above those given in the Recommended operating conditions section (if present) or the Characteristics sections of this document is not warranted. Constant or repeated exposure to limiting values will permanently and irreversibly affect the quality and reliability of the device.

Terms and conditions of commercial sale — NXP Semiconductors products are sold subject to the general terms and conditions of commercial sale, as published at <http://www.nxp.com/profile/terms>, unless otherwise agreed in a valid written individual agreement. In case an individual agreement is concluded only the terms and conditions of the respective agreement shall apply. NXP Semiconductors hereby expressly objects to applying the customer's general terms and conditions with regard to the purchase of NXP Semiconductors products by customer.

No offer to sell or license — Nothing in this document may be interpreted or construed as an offer to sell products that is open for acceptance or the grant, conveyance or implication of any license under any copyrights, patents or other industrial or intellectual property rights.

Export control — This document as well as the item(s) described herein may be subject to export control regulations. Export might require a prior authorization from competent authorities.

Non-automotive qualified products — Unless this data sheet expressly states that this specific NXP Semiconductors product is automotive qualified, the product is not suitable for automotive use. It is neither qualified nor tested in accordance with automotive testing or application requirements. NXP Semiconductors accepts no liability for inclusion and/or use of non-automotive qualified products in automotive equipment or applications.

In the event that customer uses the product for design-in and use in automotive applications to automotive specifications and standards, customer (a) shall use the product without NXP Semiconductors' warranty of the product for such automotive applications, use and specifications, and (b) whenever customer uses the product for automotive applications beyond

NXP Semiconductors' specifications such use shall be solely at customer's own risk, and (c) customer fully indemnifies NXP Semiconductors for any liability, damages or failed product claims resulting from customer design and use of the product for automotive applications beyond NXP Semiconductors' standard warranty and NXP Semiconductors' product specifications.

Translations — A non-English (translated) version of a document is for reference only. The English version shall prevail in case of any discrepancy between the translated and English versions.

15.4 Trademarks

Notice: All referenced brands, product names, service names and trademarks are the property of their respective owners.

16. Contact information

For more information, please visit: <http://www.nxp.com>

For sales office addresses, please send an email to: salesaddresses@nxp.com

17. Contents

1	General description	1
2	Features and benefits	1
3	Ordering information	2
4	Functional diagram	2
5	Pinning information	3
5.1	Pinning	3
5.2	Pin description	4
6	Functional description	4
7	Limiting values	5
8	Recommended operating conditions	5
9	Static characteristics	6
10	Dynamic characteristics	9
11	Waveforms	12
12	Package outline	14
13	Abbreviations	18
14	Revision history	18
15	Legal information	19
15.1	Data sheet status	19
15.2	Definitions	19
15.3	Disclaimers	19
15.4	Trademarks	20
16	Contact information	20
17	Contents	21

Please be aware that important notices concerning this document and the product(s) described herein, have been included in section 'Legal information'.

© NXP B.V. 2012.

All rights reserved.

For more information, please visit: <http://www.nxp.com>

For sales office addresses, please send an email to: salesaddresses@nxp.com

Date of release: 4 September 2012

Document identifier: 74HC_HCT366