

## PI3EQX6801

### 6.5Gbps, 1-port, 1.5V/3.3V SATA/SAS ReDriver™ with Analog/Digital Configuration

Pericom Semiconductor's PI3EQX6801 is a low power, 1.5V/3.3V, 6.5Gbps, SATA/SAS signal ReDriver™. The device provides programmable equalization, to optimize performance over a variety of physical mediums by reducing Inter-Symbol Interference.

PI3EQX6801 supports two 100Ω Differential CML data I/O's between the Protocol ASIC to a switch fabric, across a backplane, or to extend the signals across other distant data pathways on the user's platform.

The integrated equalization circuitry provides flexibility with signal integrity of the signal before the ReDriver.

A low-level input signal detection and output squelch function is provided for each channel. Each channel operates fully independently. When the channels are enabled ( $x\_EN\# = 0$ ) and operating, that channels input signal level (on  $xI+/-$ ) determines whether the output is active. If the input signal level of the channel falls below the active threshold level ( $V_{th-}$ ) then the outputs are driven to the common mode voltage.

Each lane can be powered-down if  $x\_EN\# = 1$ , and when  $A\_EN\#$  and  $B\_EN\#$  are both high, the device enters a low power standby mode.

#### Applications

- Server
- Desktop
- Data Storage/Workstation

#### Block Diagram

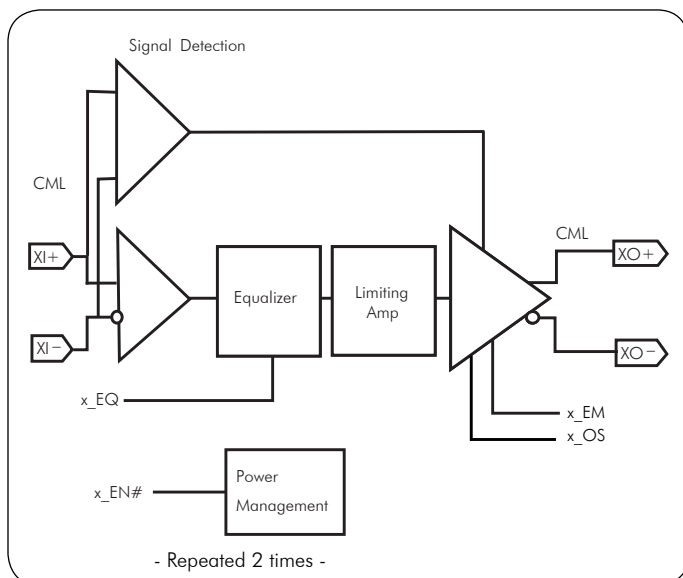

#### Features

- Two 6.5Gbps differential channels
- Output swing up to 1.2V pk-to-pk
- SAS, SATA fully supported
- Adjustable Receiver Equalization - 0 to 16 dB
- 100Ω Differential CML I/O's
- Continuous step output swing adjustment
- Continuous step output pre-emphasis control
- Input signal level detect and squelch for each channel
- OOB fully supported
- Auto HDD Rate Detection for out swing/emphasis setting
- Supply Voltage: 1.5V or 3.3V
- Low Power, 162mW @ 1.5V (600 mV Swing)
- Stand-by Mode – Power Down State: Current < 56 μA
- HDD unplug power: 1.5mW
- Auto Slumber Mode power: 22.5mW typical
- Industrial Temperature Range -40 to 85°C
- Packaging: 20-contact TQFN (4x4mm)

#### ReDriver in Storage Array Application

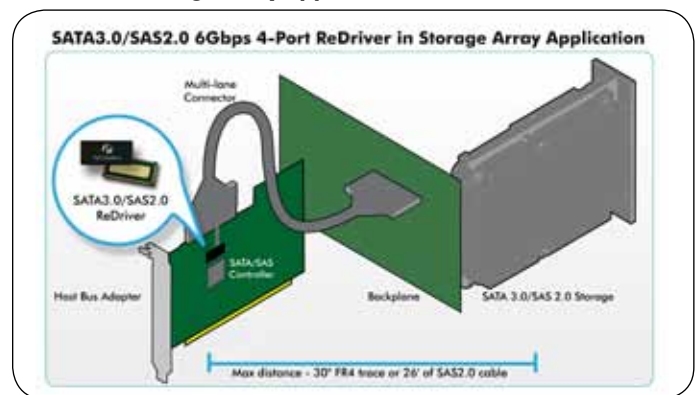

**Figure 1**

Redrivers with emphasis and equalization signal conditioning technology ensure the integrity of high-frequency SAS2.0/SATA3.0 signals by opening closed signal eyes to recover data and meet strict compliance testing requirements. Increased signal margin also supports longer drive lengths over even low-quality cables