



3.3V CMOS 32-BIT EDGE-TRIGGERED D-TYPE FLIP-FLOP WITH 3-STATE OUTPUTS AND BUS-HOLD

IDT74ALVCH32374

FEATURES:

- 0.5 MICRON CMOS Technology
- Typical $t_{sk(o)}$ (Output Skew) < 250ps
- ESD > 2000V per MIL-STD-883, Method 3015; > 200V using machine model (C = 200pF, R = 0)
- $V_{cc} = 3.3V \pm 0.3V$, Normal Range
- $V_{cc} = 2.7V$ to $3.6V$, Extended Range
- $V_{cc} = 2.5V \pm 0.2V$
- CMOS power levels (0.4μ W typ. static)
- Rail-to-Rail output swing for increased noise margin
- Available in 96-ball LFBGA package

DRIVE FEATURES:

- High Output Drivers: $\pm 24mA$
- Suitable for Heavy Loads

APPLICATIONS:

- 3.3V high speed systems
- 3.3V and lower voltage computing systems

DESCRIPTION:

This 32-bit edge-triggered D-type flip-flop is built using advanced dual metal CMOS technology. This high-speed, low-power register is ideal for use as a buffer register for data synchronization and storage. The Output Enable (\overline{OE}) and clock (CLK) controls are organized to operate the device as four 8-bit registers, two 16-bit registers, or one 32-bit register with common clock. Flow-through organization of signal pins simplifies layout. All inputs are designed with hysteresis for improved noise margin.

The ALVCH32374 has been designed with a $\pm 24mA$ output driver. This driver is capable of driving a moderate to heavy load while maintaining speed performance.

The ALVCH32374 has "bus-hold" which retains the inputs' last state whenever the input goes to a high impedance. This prevents floating inputs and eliminates the need for pull-up/down resistor.

FUNCTIONAL BLOCK DIAGRAM

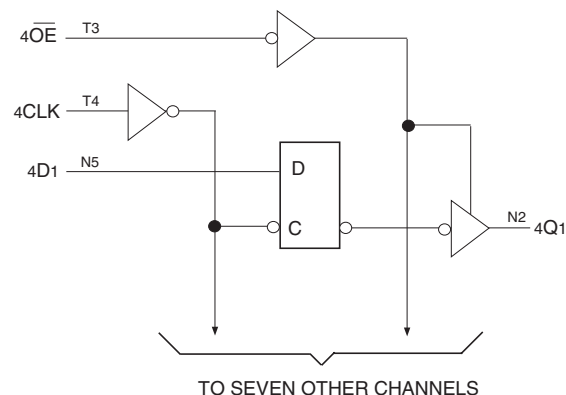
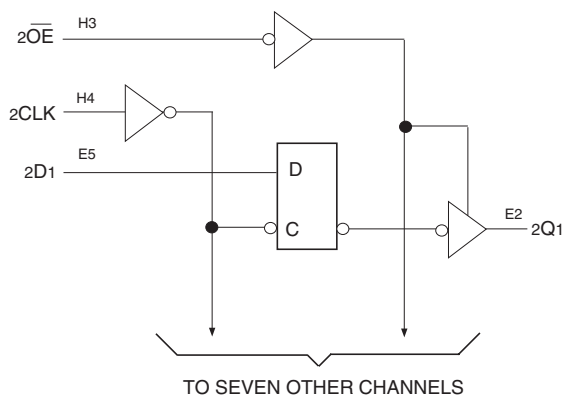
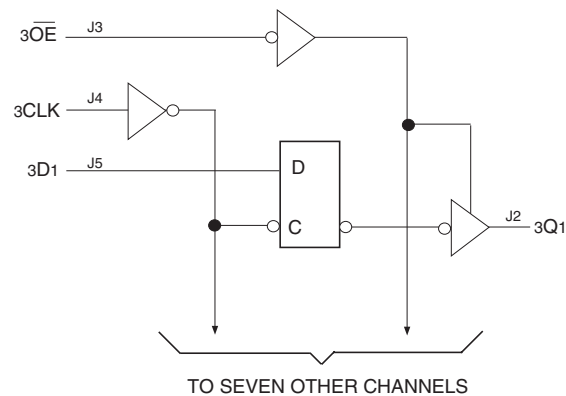
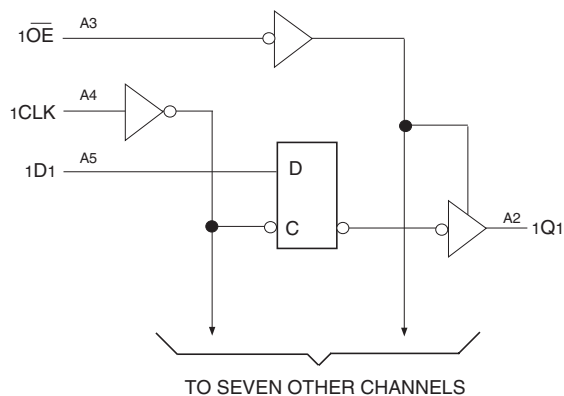

The IDT logo is a registered trademark of Integrated Device Technology, Inc.

INDUSTRIAL TEMPERATURE RANGE

AUGUST 2009

PIN CONFIGURATION

6	1D2	1D4	1D6	1D8	2D2	2D4	2D6	2D7	3D2	3D4	3D6	3D8	4D2	4D4	4D6	4D7
5	1D1	1D3	1D5	1D7	2D1	2D3	2D5	2D8	3D1	3D3	3D5	3D7	4D1	4D3	4D5	4D8
4	1CLK	GND	VCC	GND	GND	VCC	GND	2CLK	3CLK	GND	VCC	GND	GND	VCC	GND	4CLK
3	1 \overline{OE}	GND	VCC	GND	GND	VCC	GND	2 \overline{OE}	3 \overline{OE}	GND	VCC	GND	GND	VCC	GND	4 \overline{OE}
2	1Q1	1Q3	1Q5	1Q7	2Q1	2Q3	2Q5	2Q8	3Q1	3Q3	3Q5	3Q7	4Q1	4Q3	4Q5	4Q8
1	1Q2	1Q4	1Q6	1Q8	2Q2	2Q4	2Q6	2Q7	3Q2	3Q4	3Q6	3Q8	4Q2	4Q4	4Q6	4Q7
	A	B	C	D	E	F	G	H	J	K	L	M	N	P	R	T

LFBGA
TOPVIEW

96 BALL LFBGA PACKAGE ATTRIBUTES

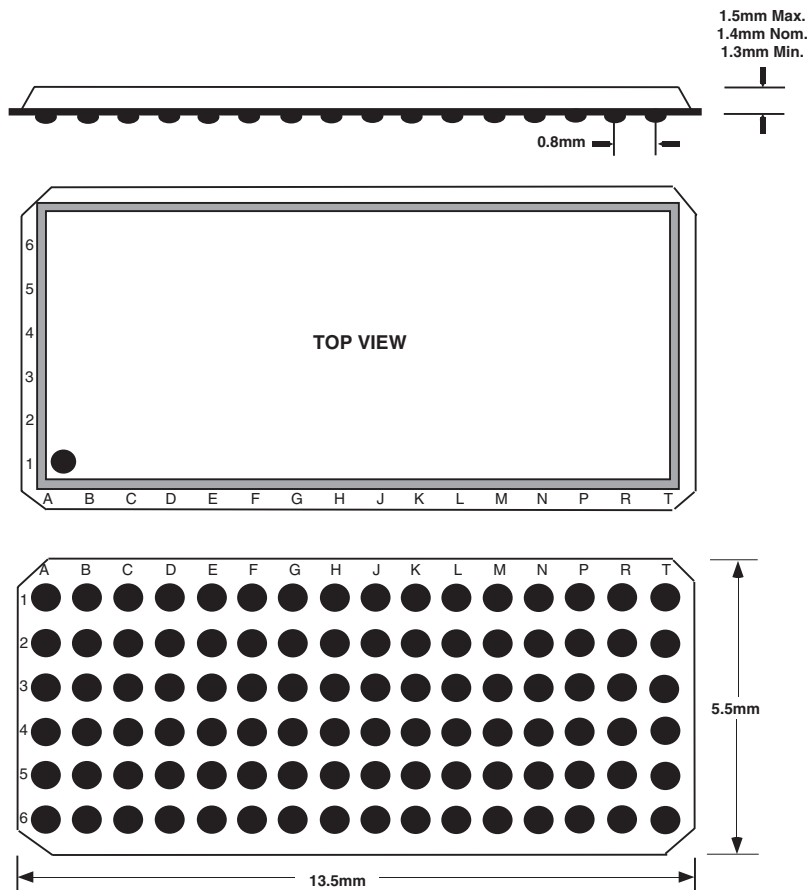

ABSOLUTE MAXIMUM RATINGS⁽¹⁾

Symbol	Description	Max	Unit
V _{TERM} ⁽²⁾	Terminal Voltage with Respect to GND	-0.5 to +4.6	V
V _{TERM} ⁽³⁾	Terminal Voltage with Respect to GND	-0.5 to V _{CC} +0.5	V
T _{STG}	Storage Temperature	-65 to +150	°C
I _{OUT}	DC Output Current	-50 to +50	mA
I _{IK}	Continuous Clamp Current, V _I < 0 or V _I > V _{CC}	±50	mA
I _{OK}	Continuous Clamp Current, V _O < 0	-50	mA
I _{CC} I _{SS}	Continuous Current through each V _{CC} or GND	±100	mA

NOTES:

- Stresses greater than those listed under ABSOLUTE MAXIMUM RATINGS may cause permanent damage to the device. This is a stress rating only and functional operation of the device at these or any other conditions above those indicated in the operational sections of this specification is not implied. Exposure to absolute maximum rating conditions for extended periods may affect reliability.
- V_{CC} terminals.
- All terminals except V_{CC}.

PIN DESCRIPTION

Pin Names	Description
xD _x	Data Inputs ⁽¹⁾
xCLK	Clock Inputs
xQ _x	3-State Outputs
$\overline{\text{xOE}}$	3-State Output Enable Inputs (Active LOW)

NOTE:

- These pins have "Bus-Hold". All other pins are standard inputs, outputs, or I/Os.

CAPACITANCE (T_A = +25°C, F = 1.0MHz)

Symbol	Parameter ⁽¹⁾	Conditions	Typ.	Max.	Unit
C _{IN}	Input Capacitance	V _{IN} = 0V	5	7	pF
C _{OUT}	Output Capacitance	V _{OUT} = 0V	7	9	pF
C _{I/O}	I/O Port Capacitance	V _{IN} = 0V	7	9	pF

NOTE:

- As applicable to the device type.

FUNCTION TABLE (EACH FLIP-FLOP)⁽¹⁾

Inputs			Outputs
$\overline{\text{xOE}}$	xCLK	xD _x	xQ _x
L	↑	H	H
L	↑	L	L
L	H or L	X	Q ⁽²⁾
H	X	X	Z

NOTES:

- H = HIGH Voltage Level
L = LOW Voltage Level
X = Don't Care
Z = High Impedance
↑ = LOW-to-HIGH Transition
- Output level of Q before the indicated steady-state conditions were established.

DC ELECTRICAL CHARACTERISTICS OVER OPERATING RANGE

Following Conditions Apply Unless Otherwise Specified:

Operating Condition: $T_A = -40^{\circ}\text{C}$ to $+85^{\circ}\text{C}$

Symbol	Parameter	Test Conditions		Min.	Typ. ⁽¹⁾	Max.	Unit
V _{IH}	Input HIGH Voltage Level	V _{CC} = 2.3V to 2.7V		1.7	—	—	V
		V _{CC} = 2.7V to 3.6V		2	—	—	
V _{IL}	Input LOW Voltage Level	V _{CC} = 2.3V to 2.7V		—	—	0.7	V
		V _{CC} = 2.7V to 3.6V		—	—	0.8	
I _{IH}	Input HIGH Current	V _{CC} = 3.6V	V _I = V _{CC}	—	—	±5	μA
I _{IL}	Input LOW Current	V _{CC} = 3.6V	V _I = GND	—	—	±5	μA
I _{OZH} I _{OZL}	High Impedance Output Current (3-State Output pins)	V _{CC} = 3.6V		—	—	±10	μA
		V _O = GND		—	—	±10	
V _{IK}	Clamp Diode Voltage	V _{CC} = 2.3V, I _{IN} = -18mA		—	-0.7	-1.2	V
V _H	Input Hysteresis	V _{CC} = 3.3V		—	100	—	mV
I _{CC1} I _{CC2} I _{CC3}	Quiescent Power Supply Current	V _{CC} = 3.6V V _{IN} = GND or V _{CC}		—	0.1	40	μA
ΔI _{CC}	Quiescent Power Supply Current Variation	One input at V _{CC} - 0.6V, other inputs at V _{CC} or GND		—	—	750	μA

NOTE:

1. Typical values are at V_{CC} = 3.3V, +25°C ambient.

BUS-HOLD CHARACTERISTICS

Symbol	Parameter ⁽¹⁾	Test Conditions		Min.	Typ. ⁽²⁾	Max.	Unit
I _{BHH} I _{BHL}	Bus-Hold Input Sustain Current	V _{CC} = 3V		—75	—	—	μA
		V _I = 0.8V		75	—	—	
I _{BHH} I _{BHL}	Bus-Hold Input Sustain Current	V _{CC} = 2.3V		-45	—	—	μA
		V _I = 0.7V		45	—	—	
I _{BHHO} I _{BHLO}	Bus-Hold Input Overdrive Current	V _{CC} = 3.6V		—	—	±500	μA

NOTES:

1. Pins with Bus-Hold are identified in the pin description.
2. Typical values are at V_{CC} = 3.3V, +25°C ambient.

OUTPUT DRIVE CHARACTERISTICS

Symbol	Parameter	Test Conditions ⁽¹⁾		Min.	Max.	Unit
VOH	Output HIGH Voltage	VCC = 2.3V to 3.6V	IOH = - 0.1mA	VCC - 0.2	—	V
		VCC = 2.3V	IOH = - 6mA	2	—	
		VCC = 2.3V	IOH = - 12mA	1.7	—	
		VCC = 2.7V		2.2	—	
		VCC = 3V		2.4	—	
		VCC = 3V	IOH = - 24mA	2	—	
VOL	Output LOW Voltage	VCC = 2.3V to 3.6V	IOL = 0.1mA	—	0.2	V
		VCC = 2.3V	IOL = 6mA	—	0.4	
			IOL = 12mA	—	0.7	
		VCC = 2.7V	IOL = 12mA	—	0.4	
		VCC = 3V	IOL = 24mA	—	0.55	

NOTE:
1. VIH and VIL must be within the min. or max. range shown in the DC ELECTRICAL CHARACTERISTICS OVER OPERATING RANGE table for the appropriate VCC range.
TA = - 40°C to + 85°C.

OPERATING CHARACTERISTICS, TA = 25°C

Symbol	Parameter	Test Conditions	VCC = 2.5V ± 0.2V	VCC = 3.3V ± 0.3V	Unit
			Typical	Typical	
CPD	Power Dissipation Capacitance Outputs enabled	CL = 0pF, f = 10Mhz	62	60	pF
CPD	Power Dissipation Capacitance Outputs disabled		32	36	

SWITCHING CHARACTERISTICS⁽¹⁾

Symbol	Parameter	VCC = 2.5V ± 0.2V		VCC = 2.7V		VCC = 3.3V ± 0.3V		Unit
		Min.	Max.	Min.	Max.	Min.	Max.	
fMAX		150	—	150	—	150	—	MHz
tPLH	Propagation Delay	1	5.3	—	4.9	1	4.2	ns
tPHL	xCLK to xQx							
tPZH	Output Enable Time	1	6.2	—	5.9	1	4.8	ns
tPZL	xOE to xQx							
tPHZ	Output Disable Time	1	5.3	—	4.7	1.2	4.3	ns
tPLZ	xOE to xQx							
tsu	Setup Time, data before CLK↑	2.1	—	2.2	—	1.9	—	ns
tH	Hold Time, data after CLK↑	0.6	—	0.5	—	0.5	—	ns
tW	Pulse Duration, CLK HIGH or LOW	3.3	—	3.3	—	3.3	—	ns
tsk(O)	Output Skew ⁽²⁾	—	—	—	—	—	500	ps

NOTES:
1. See TEST CIRCUITS AND WAVEFORMS. TA = - 40°C to + 85°C.
2. Skew between any two outputs of the same package and switching in the same direction.

TEST CIRCUITS AND WAVEFORMS

TEST CONDITIONS

Symbol	V _{CC} ⁽¹⁾ = 3.3V ± 0.3V	V _{CC} ⁽¹⁾ = 2.7V	V _{CC} ⁽²⁾ = 2.5V ± 0.2V	Unit
V _{LOAD}	6	6	2 x V _{CC}	V
V _{IH}	2.7	2.7	V _{CC}	V
V _T	1.5	1.5	V _{CC} / 2	V
V _{LZ}	300	300	150	mV
V _{HZ}	300	300	150	mV
C _L	50	50	30	pF

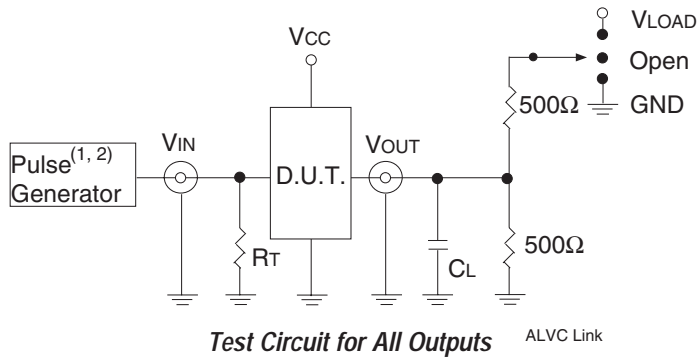

DEFINITIONS:

C_L = Load capacitance: includes jig and probe capacitance.
R_T = Termination resistance: should be equal to Z_{OUT} of the Pulse Generator.

NOTES:

1. Pulse Generator for All Pulses: Rate ≤ 1.0MHz; t_r ≤ 2.5ns; t_r ≤ 2.5ns.
2. Pulse Generator for All Pulses: Rate ≤ 1.0MHz; t_r ≤ 2ns; t_r ≤ 2ns.

SWITCH POSITION

Test	Switch
Open Drain Disable Low Enable Low	V _{LOAD}
Disable High Enable High	GND
All Other Tests	Open

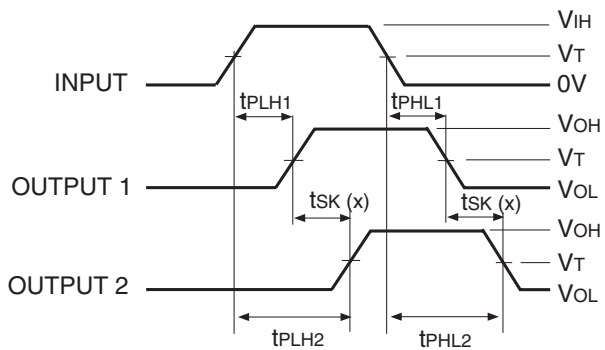

NOTES:

1. For tsk(o) OUTPUT1 and OUTPUT2 are any two outputs.
2. For tsk(b) OUTPUT1 and OUTPUT2 are in the same bank.

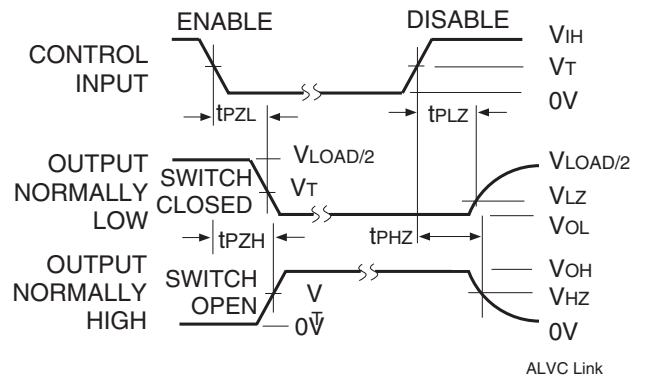
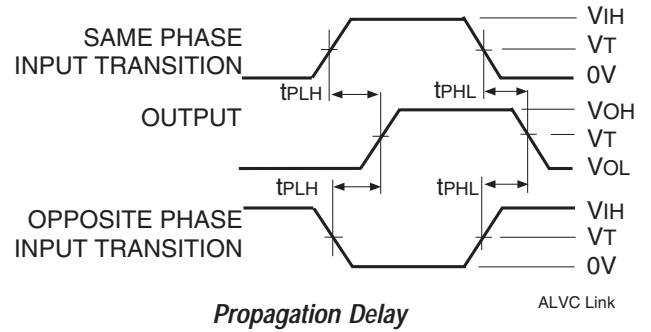

NOTE:

1. Diagram shown for input Control Enable-LOW and input Control Disable-HIGH.

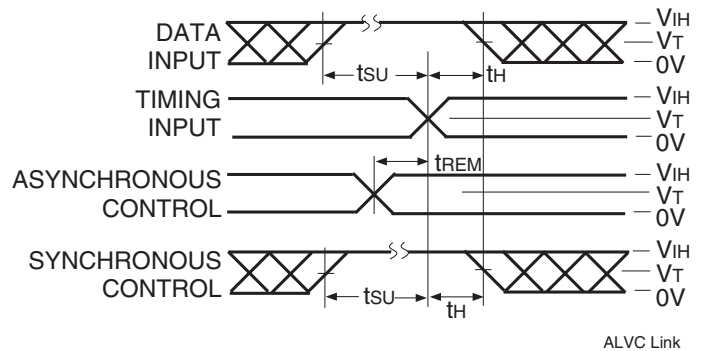

Set-up, Hold, and Release Times

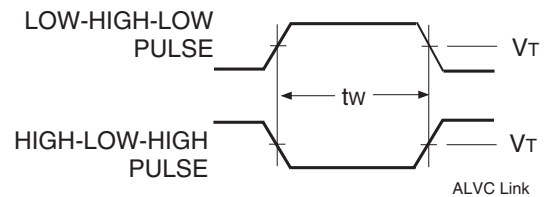

ORDERING INFORMATION

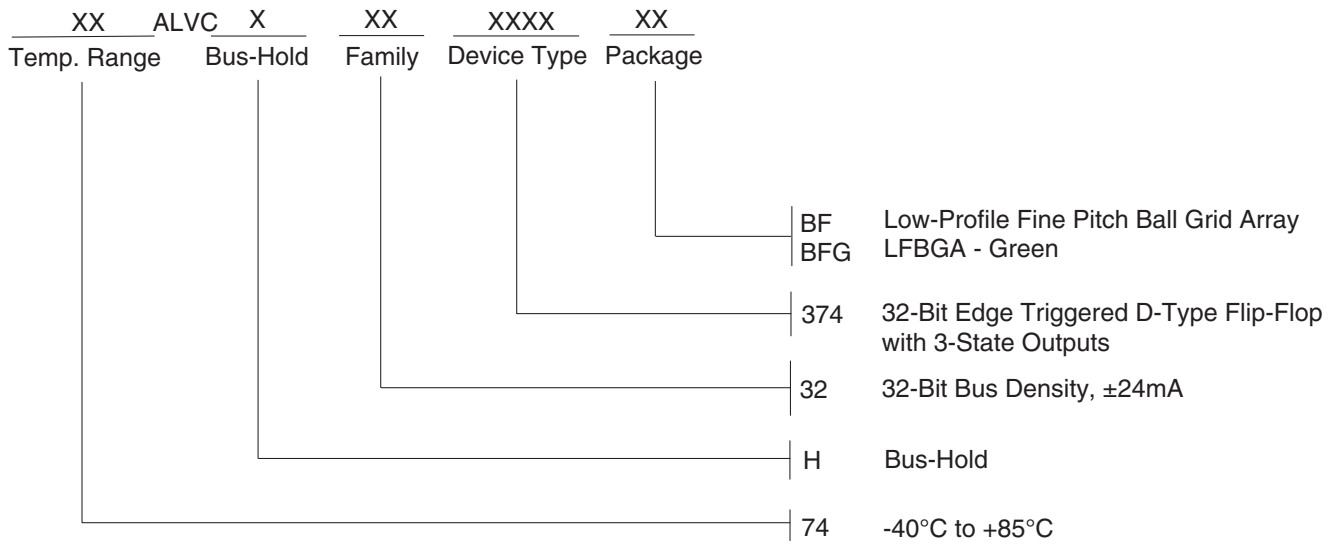

CORPORATE HEADQUARTERS
 6024 Silver Creek Valley Road
 San Jose, CA 95138

for SALES:
 800-345-7015 or 408-284-8200
 fax: 408-284-2775
 www.idt.com

for Tech Support:
 logichelp@idt.com