

9 BIT PARITY GENERATOR

- HIGH SPEED:
 $t_{PD} = 8 \text{ ns (TYP.) at } V_{CC} = 3.3 \text{ V}$
- COMPATIBLE WITH TTL OUTPUTS
- LOW POWER DISSIPATION:
 $I_{CC} = 2\mu\text{A (MAX.) at } T_A = 25^\circ\text{C}$
- LOW NOISE:
 $V_{OLP} = 0.3\text{V (TYP.) at } V_{CC} = 3.3\text{V}$
- 75Ω TRANSMISSION LINE DRIVING CAPABILITY
- SYMMETRICAL OUTPUT IMPEDANCE:
 $|I_{OH}| = I_{OL} = 12\text{mA (MIN) at } V_{CC} = 3.0 \text{ V}$
- PCI BUS LEVELS GUARANTEED AT 24 mA
- BALANCED PROPAGATION DELAYS:
 $t_{PLH} \cong t_{PHL}$
- OPERATING VOLTAGE RANGE:
 $V_{CC(OPR)} = 2\text{V to } 3.6\text{V}$
- PIN AND FUNCTION COMPATIBLE WITH 74 SERIES 280
- IMPROVED LATCH-UP IMMUNITY

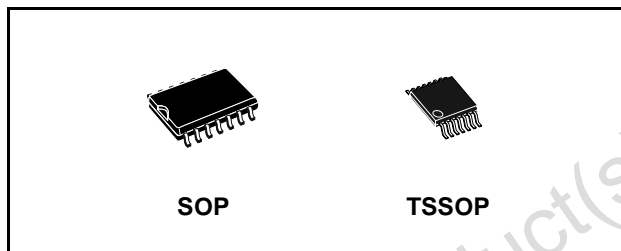

Table 1: Order Codes

PACKAGE	T & R
SOP	74LVQ280MTR
TSSOP	74LVQ280TTR

DESCRIPTION

The 74LVQ280 is a low voltage CMOS 9 BIT PARITY GENERATOR fabricated with sub-micron silicon gate and double-layer metal wiring C²MOS technology. It is ideal for low power and low noise 3.3V applications.

It is composed of nine data inputs (A to I) and odd/even parity outputs (ΣODD and ΣEVEN). The nine

data inputs control the output conditions. When the number of high level input is odd, ΣODD output is kept high and ΣEVEN output low. Conversely, when the number of high level is even, ΣEVEN output is kept high and ΣODD low. The IC generates either odd or even parity making it a flexible application. The word-length capability is easily expanded by cascading. All inputs and outputs are equipped with protection circuits against static discharge, giving them 2KV ESD immunity and transient excess voltage.

Figure 1: Pin Connection And IEC Logic Symbols

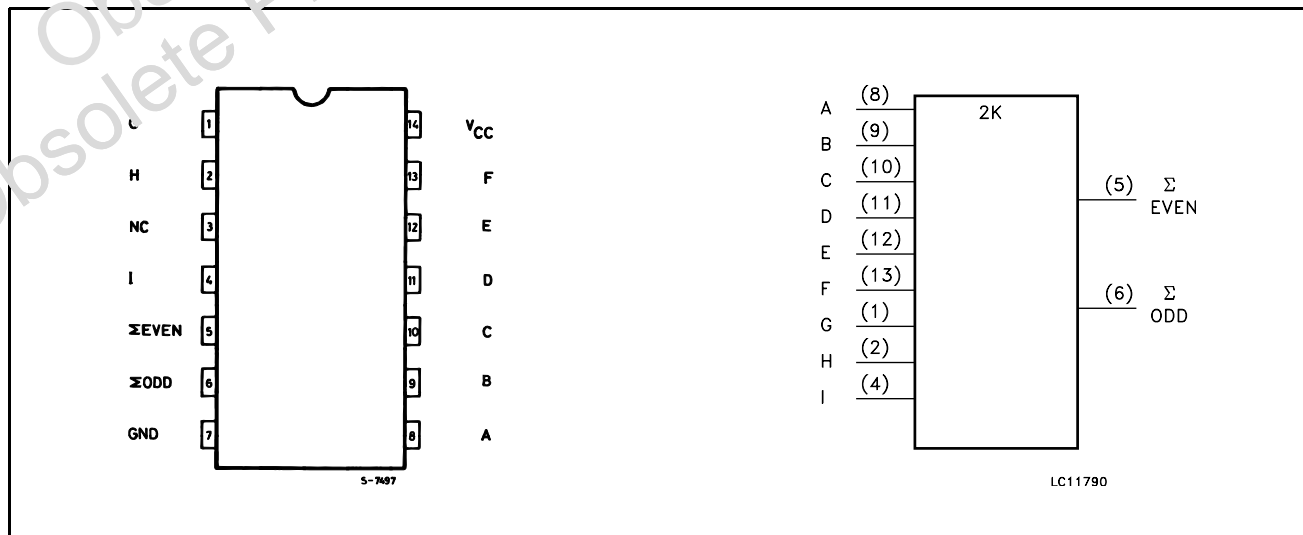

Figure 2: Input And Output Equivalent Circuit

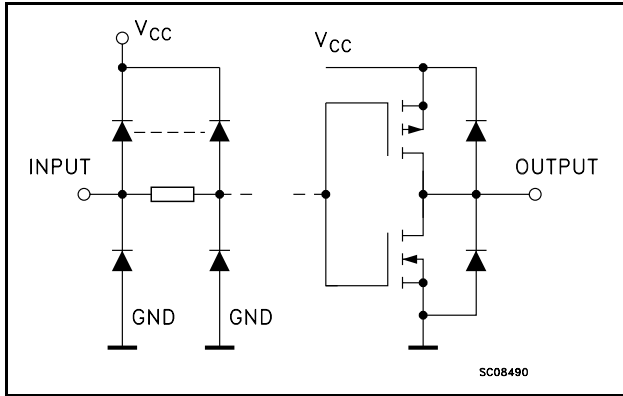

Table 2: Pin Description

PIN N°	SYMBOL	NAME AND FUNCTION
5	Σ EVEN	Even Parity Output
6	Σ ODD	Odd Parity Output
8, 9, 10, 11, 12, 13, 1, 2, 4	A to I	Data Inputs
3	NC	No Connection
7	GND	Ground (0V)
14	V _{CC}	Positive Supply Voltage

Table 3: Truth Table

NUMBER OF INPUTS A - I THAT ARE HIGH	OUTPUTS	
	Σ EVEN	Σ ODD
0, 2, 4, 6, 8	H	L
1, 3, 5, 7, 9	L	H

Figure 3: Logic Diagram

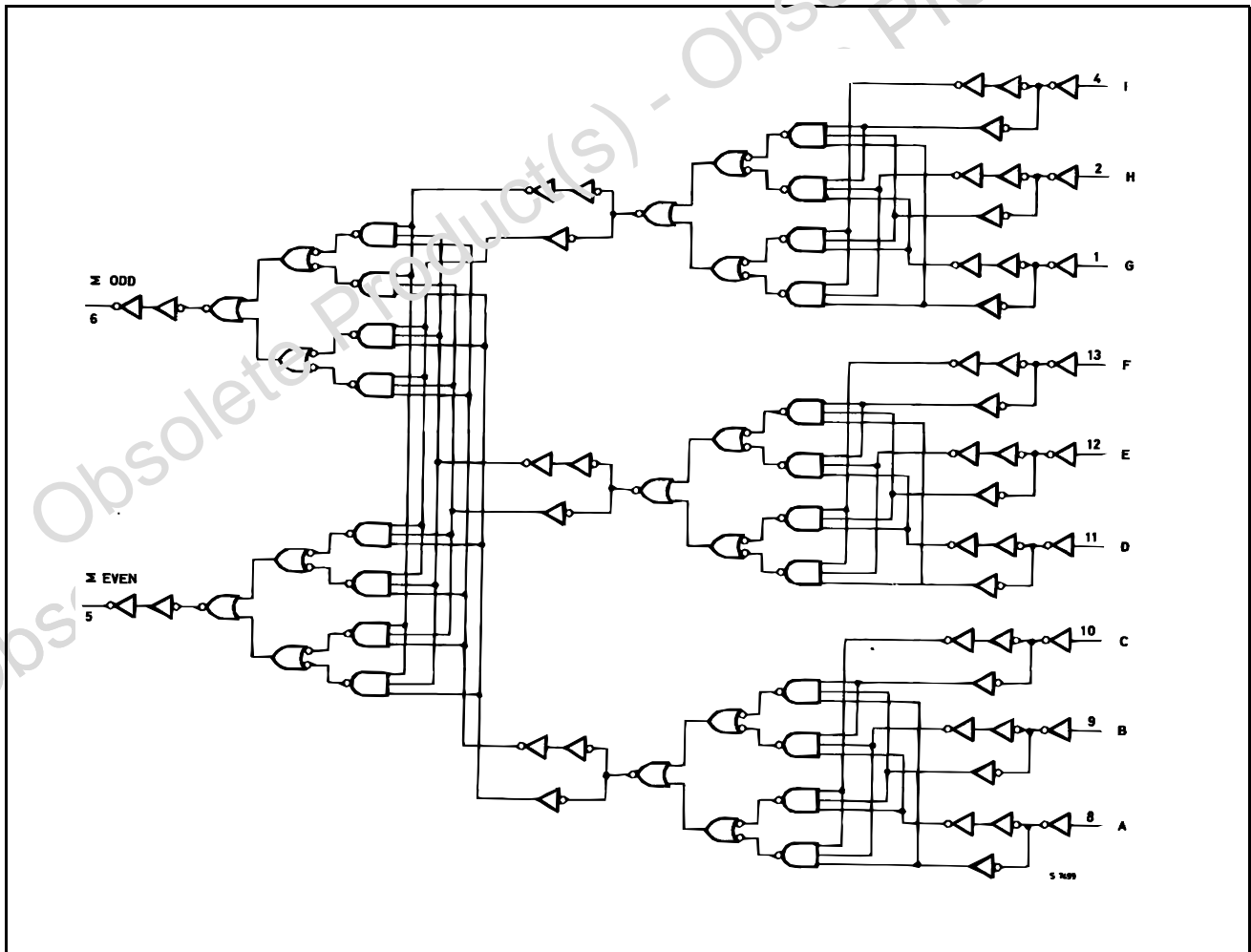

Table 4: Absolute Maximum Ratings

Symbol	Parameter	Value	Unit
V_{CC}	Supply Voltage	-0.5 to +7	V
V_I	DC Input Voltage	-0.5 to $V_{CC} + 0.5$	V
V_O	DC Output Voltage	-0.5 to $V_{CC} + 0.5$	V
I_{IK}	DC Input Diode Current	± 20	mA
I_{OK}	DC Output Diode Current	± 20	mA
I_O	DC Output Current	± 50	mA
I_{CC} or I_{GND}	DC V_{CC} or Ground Current	± 300	mA
T_{stg}	Storage Temperature	-65 to +150	°C
T_L	Lead Temperature (10 sec)	300	°C

Absolute Maximum Ratings are those values beyond which damage to the device may occur. Functional operation under these conditions is not implied.

Table 5: Recommended Operating Conditions

Symbol	Parameter	Value	Unit
V_{CC}	Supply Voltage (note 1)	2 to 3.6	V
V_I	Input Voltage	0 to V_{CC}	V
V_O	Output Voltage	0 to V_{CC}	V
T_{op}	Operating Temperature	-55 to 125	°C

1) Truth Table guaranteed: 1.2V to 3.6V

Table 6: DC Specifications

Symbol	Parameter	Test Condition		Value						Unit	
		V_{CC} (V)		$T_A = 25^\circ\text{C}$			-40 to 85°C		-55 to 125°C		
				Min.	Typ.	Max.	Min.	Max.	Min.		Max.
V_{IH}	High Level Input Voltage	3.0 to 3.6		2.0			2.0		2.0		V
V_{IL}	Low Level Input Voltage					0.8		0.8		0.8	V
V_{OH}	High Level Output Voltage	3.0	$I_O = -50 \mu\text{A}$	2.9	2.99		2.9		2.9		V
			$I_O = -12 \text{ mA}$	2.58			2.48		2.48		
			$I_O = -24 \text{ mA}$				2.2		2.2		
V_{OL}	Low Level Output Voltage	3.0	$I_O = 50 \mu\text{A}$		0.002	0.1		0.1		0.1	V
			$I_O = 12 \text{ mA}$		0	0.36		0.44		0.44	
			$I_O = 24 \text{ mA}$					0.55		0.55	
I_I	Input Leakage Current	3.6	$V_I = V_{CC}$ or GND			± 0.1		± 1		± 1	μA
I_{CC}	Quiescent Supply Current	3.6	$V_I = V_{CC}$ or GND			2		20		20	μA
I_{OLD}	Dynamic Output Current (note 1, 2)	3.6	$V_{OLD} = 0.8 \text{ V max}$				36		25		mA
I_{OHD}			$V_{OHD} = 2 \text{ V min}$				-25		-25		mA

1) Maximum test duration 2ms, one output loaded at time

2) Incident wave switching is guaranteed on transmission lines with impedances as low as 75Ω

Table 7: Dynamic Switching Characteristics

Symbol	Parameter	Test Condition		Value						Unit	
		V _{CC} (V)		T _A = 25°C			-40 to 85°C		-55 to 125°C		
				Min.	Typ.	Max.	Min.	Max.	Min.		Max.
V _{OLP}	Dynamic Low Voltage Quiet Output (note 1, 2)	3.3	C _L = 50 pF		0.3	0.8					V
V _{OLV}				-0.8	-0.3						
V _{IHD}	Dynamic High Voltage Input (note 1, 3)	3.3		2						V	
V _{ILD}	Dynamic Low Voltage Input (note 1, 3)	3.3				0.8					V

1) Worst case package.

2) Max number of outputs defined as (n). Data inputs are driven 0V to 3.3V, (n-1) outputs switching and one output at GND.

3) Max number of data inputs (n) switching. (n-1) switching 0V to 3.3V. Inputs under test switching: 3.3V to threshold (V_{IL}), 0V to threshold (V_{IHD}), f=1MHz.

Table 8: AC Electrical Characteristics (C_L = 50 pF, R_L = 500 Ω, Input t_r = t_f = 3ns)

Symbol	Parameter	Test Condition		Value						Unit	
		V _{CC} (V)		T _A = 25°C			-40 to 85°C		-55 to 125°C		
				Min.	Typ.	Max.	Min.	Max.	Min.		Max.
t _{PLH} t _{PHL}	Propagation Delay Time	2.7		3.9	16.0		19.0		22.0	ns	
		3.3(*)		8.0	11.5		13.5		16.0		
t _{OSLH} t _{OSHL}	Output To Output Skew Time (note1, 2)	2.7		0.5	1.0		1.0		1.0	ns	
		3.3(*)		0.5	1.0		1.0		1.0		

1) Skew is defined as the absolute value of the difference between the actual propagation delay for any two outputs of the same device switching in the same direction, either HIGH or LOW. (t_{OSLH} = |t_{PLHm} - t_{PLHn}|, t_{OSHL} = |t_{PHLm} - t_{PHLn}|)

2) Parameter guaranteed by design

(*) Voltage range is 3.3V ± 0.3V

Table 9: Capacitive Characteristics

Symbol	Parameter	Test Condition		Value						Unit	
		V _{CC} (V)		T _A = 25°C			-40 to 85°C		-55 to 125°C		
				Min.	Typ.	Max.	Min.	Max.	Min.		Max.
C _{IN}	Input Capacitance	3.3			4					pF	
C _{PD}	Power Dissipation Capacitance (note 1)	3.3	f _{IN} = 10MHz		59					pF	

1) C_{PD} is defined as the value of the IC's internal equivalent capacitance which is calculated from the operating current consumption without load. (Refer to Test Circuit). Average operating current can be obtained by the following equation. I_{CC(opr)} = C_{PD} × V_{CC} × f_{IN} + I_{CC}/n (per circuit)

Figure 4: Test Circuit

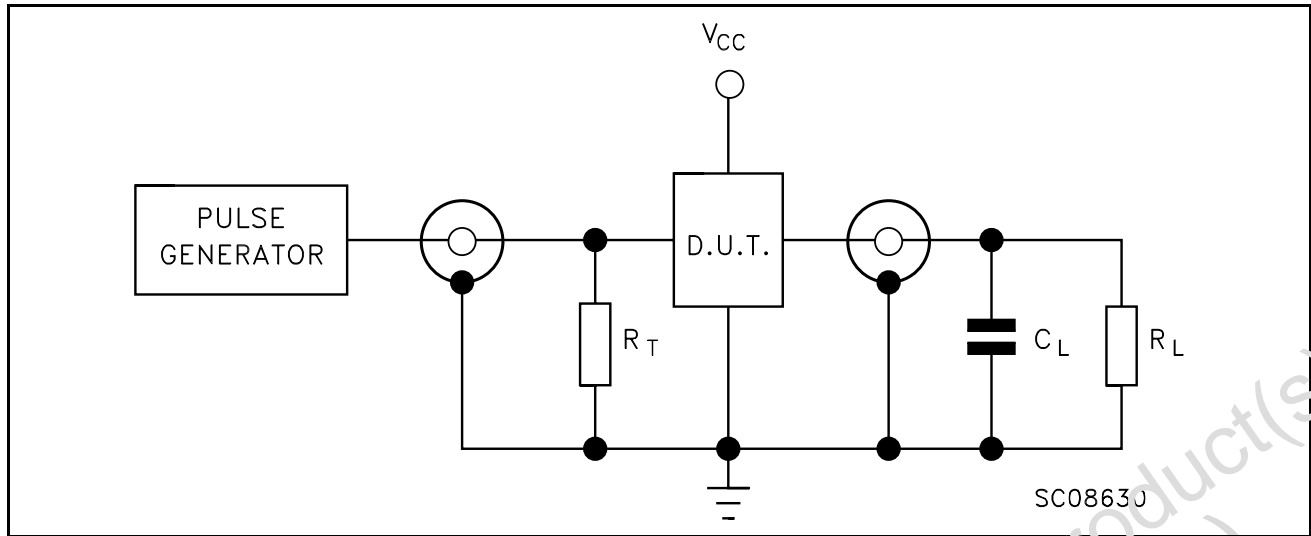

$C_L = 50\text{pF}$ or equivalent (includes jig and probe capacitance)
 $R_L = 500\Omega$ or equivalent
 $R_T = Z_{\text{OUT}}$ of pulse generator (typically 50Ω)

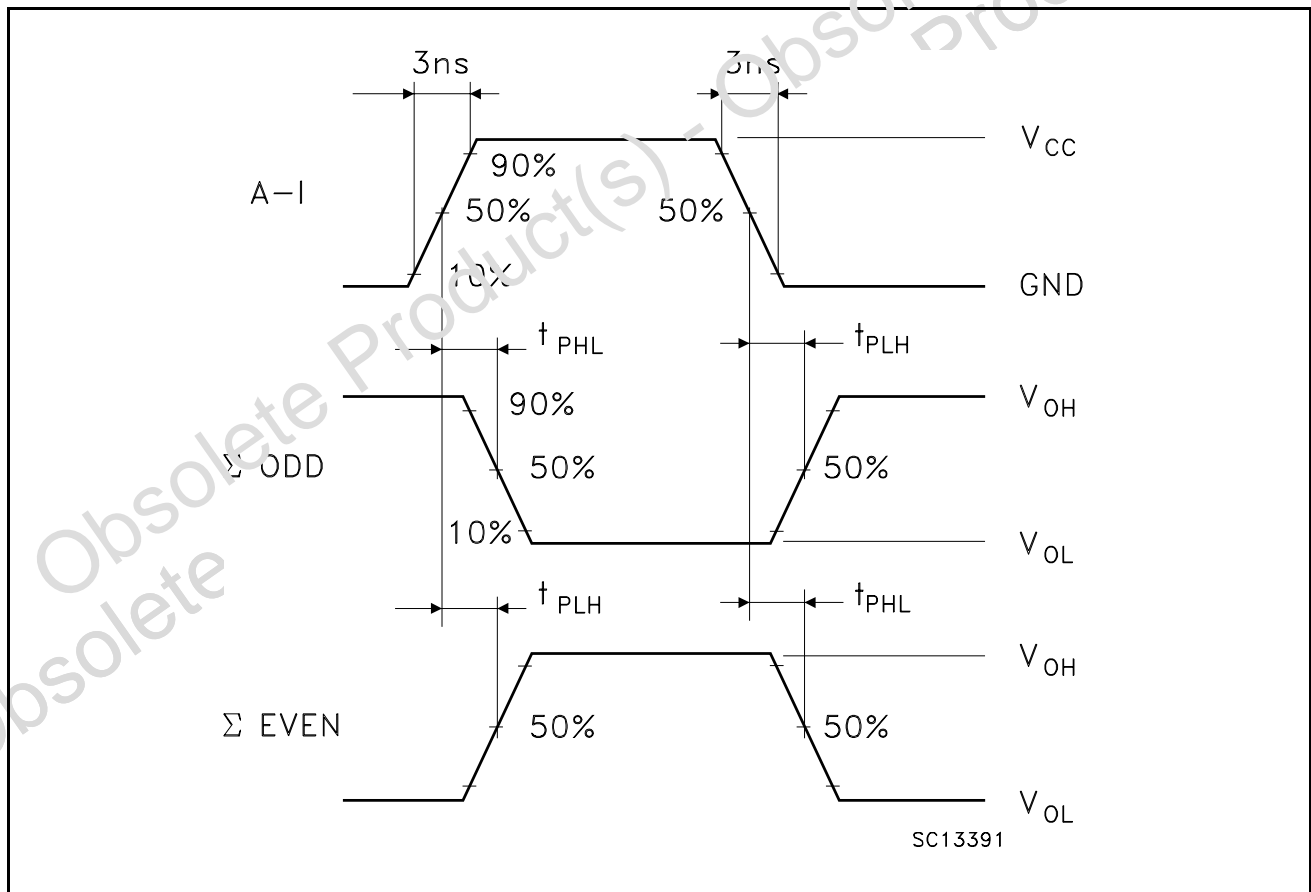
Figure 5: Waveform - Propagation Delays ($f=1\text{MHz}$; 50% duty cycle)

SO-14 MECHANICAL DATA

DIM.	mm.			inch		
	MIN.	TYP	MAX.	MIN.	TYP.	MAX.
A	1.35		1.75	0.053		0.069
A1	0.1		0.25	0.004		0.010
A2	1.10		1.65	0.043		0.065
B	0.33		0.51	0.013		0.020
C	0.19		0.25	0.007		0.010
D	8.55		8.75	0.337		0.344
E	3.8		4.0	0.150		0.157
e		1.27			0.050	
H	5.8		6.2	0.228		0.244
h	0.25		0.50	0.010		0.020
L	0.4		1.27	0.016		0.050
k	0°		8°	0°		8°
ddd			0.100			0.004

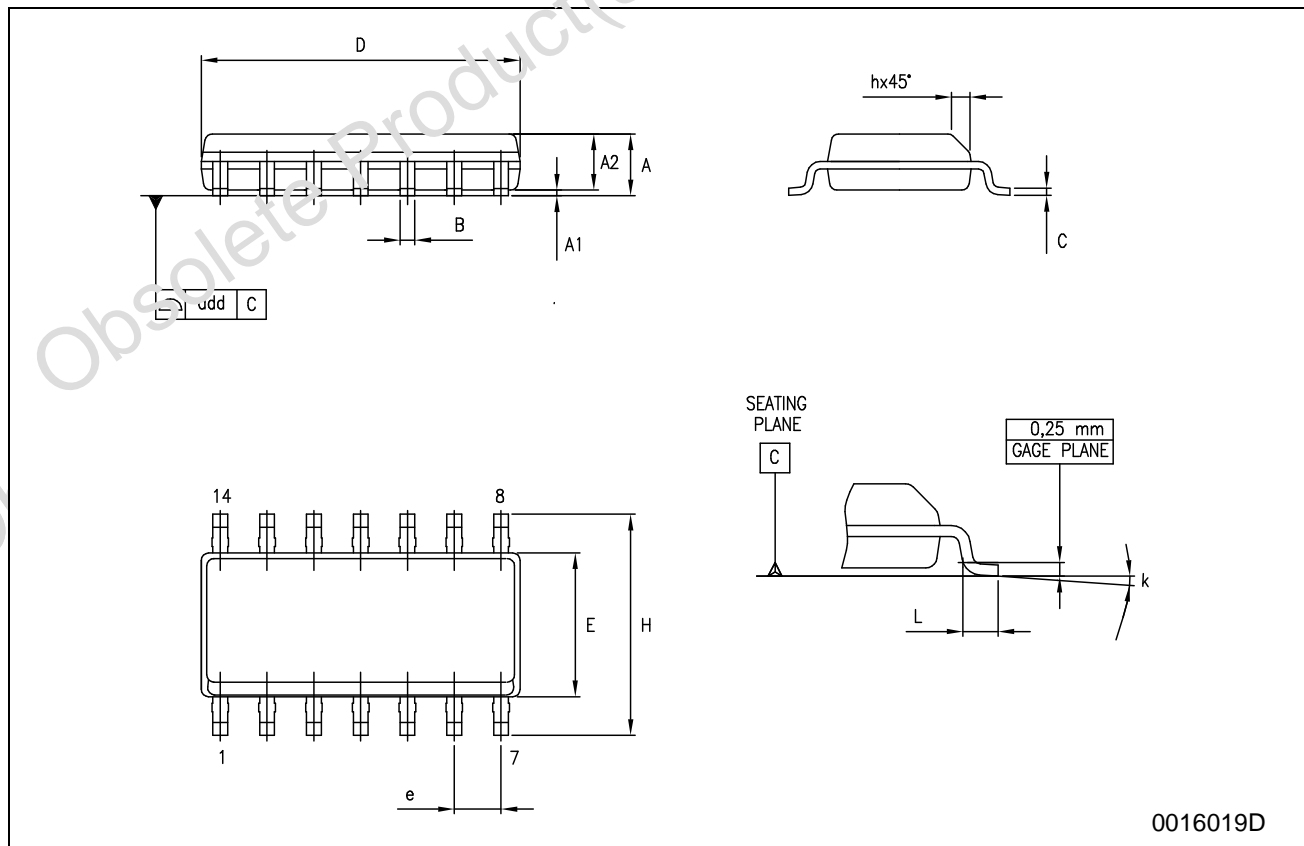

TSSOP14 MECHANICAL DATA

DIM.	mm.			inch		
	MIN.	TYP	MAX.	MIN.	TYP.	MAX.
A			1.2			0.047
A1	0.05		0.15	0.002	0.004	0.006
A2	0.8	1	1.05	0.031	0.039	0.041
b	0.19		0.30	0.007		0.012
c	0.09		0.20	0.004		0.008
D	4.9	5	5.1	0.193	0.197	0.201
E	6.2	6.4	6.6	0.244	0.252	0.260
E1	4.3	4.4	4.48	0.169	0.173	0.176
e		0.65 BSC			0.0256 BSC	
K	0°		8°	0°		8°
L	0.45	0.60	0.75	0.018	0.024	0.030

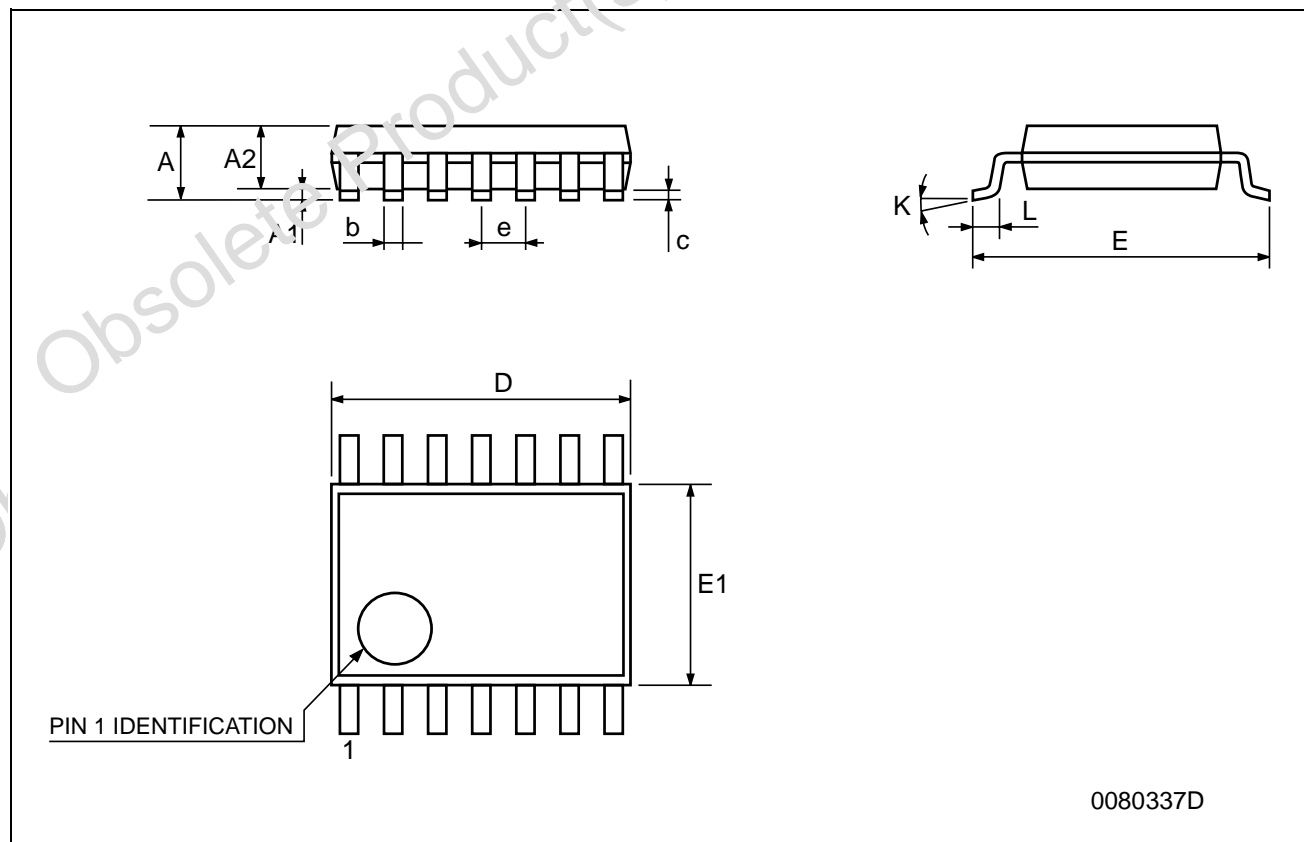

Tape & Reel SO-14 MECHANICAL DATA

DIM.	mm.			inch		
	MIN.	TYP.	MAX.	MIN.	TYP.	MAX.
A			330			12.992
C	12.8		13.2	0.504		0.519
D	20.2			0.795		
N	60			2.362		
T			22.4			0.882
Ao	6.4		6.6	0.252		0.260
Bo	9		9.2	0.354		0.362
Ko	2.1		2.3	0.082		0.090
Po	3.9		4.1	0.153		0.161
P	7.9		8.1	0.311		0.319

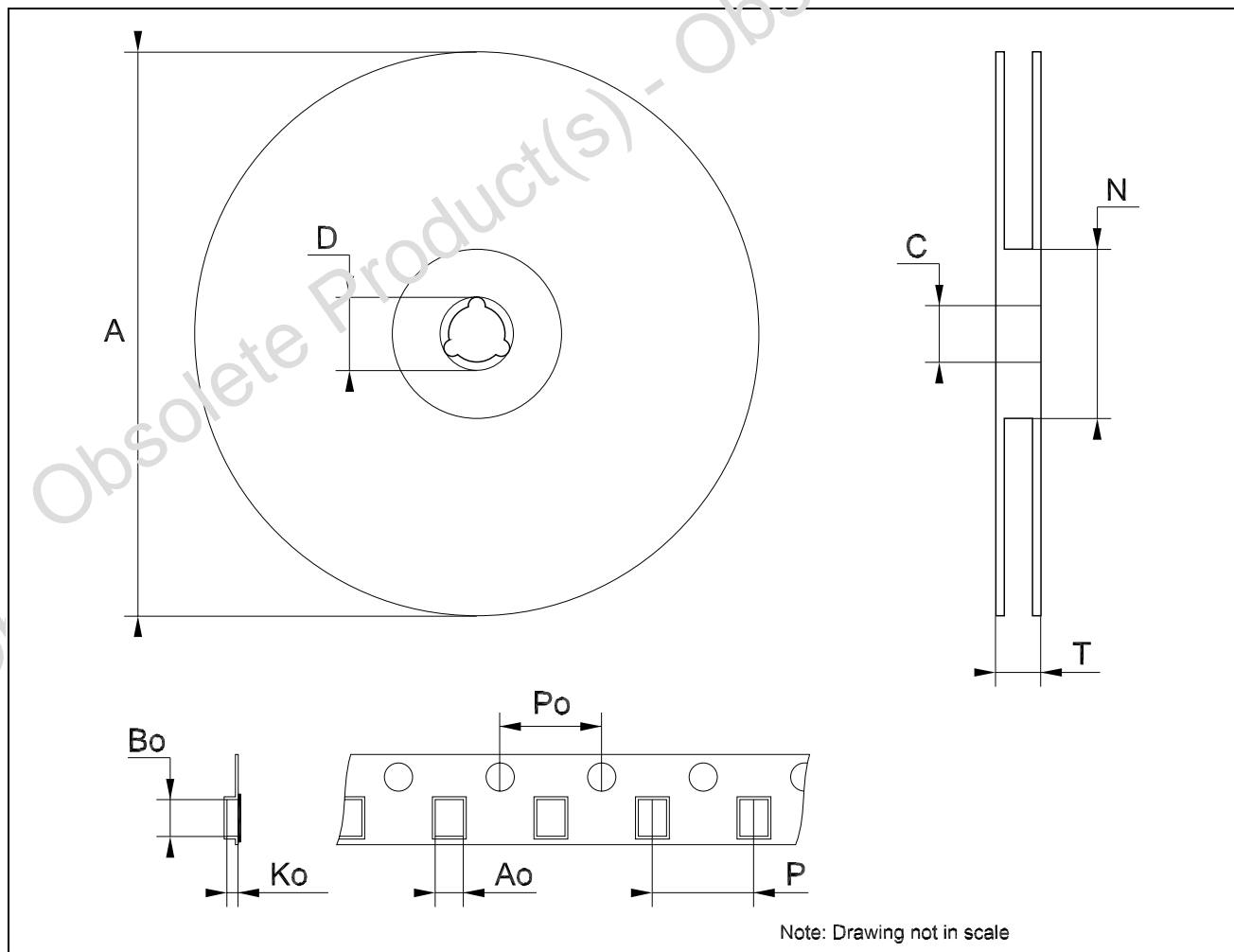

Tape & Reel TSSOP14 MECHANICAL DATA

DIM.	mm.			inch		
	MIN.	TYP.	MAX.	MIN.	TYP.	MAX.
A			330			12.992
C	12.8		13.2	0.504		0.519
D	20.2			0.795		
N	60			2.362		
T			22.4			0.882
Ao	6.7		6.9	0.264		0.272
Bo	5.3		5.5	0.209		0.217
Ko	1.6		1.8	0.063		0.071
Po	3.9		4.1	0.153		0.161
P	7.9		8.1	0.311		0.319

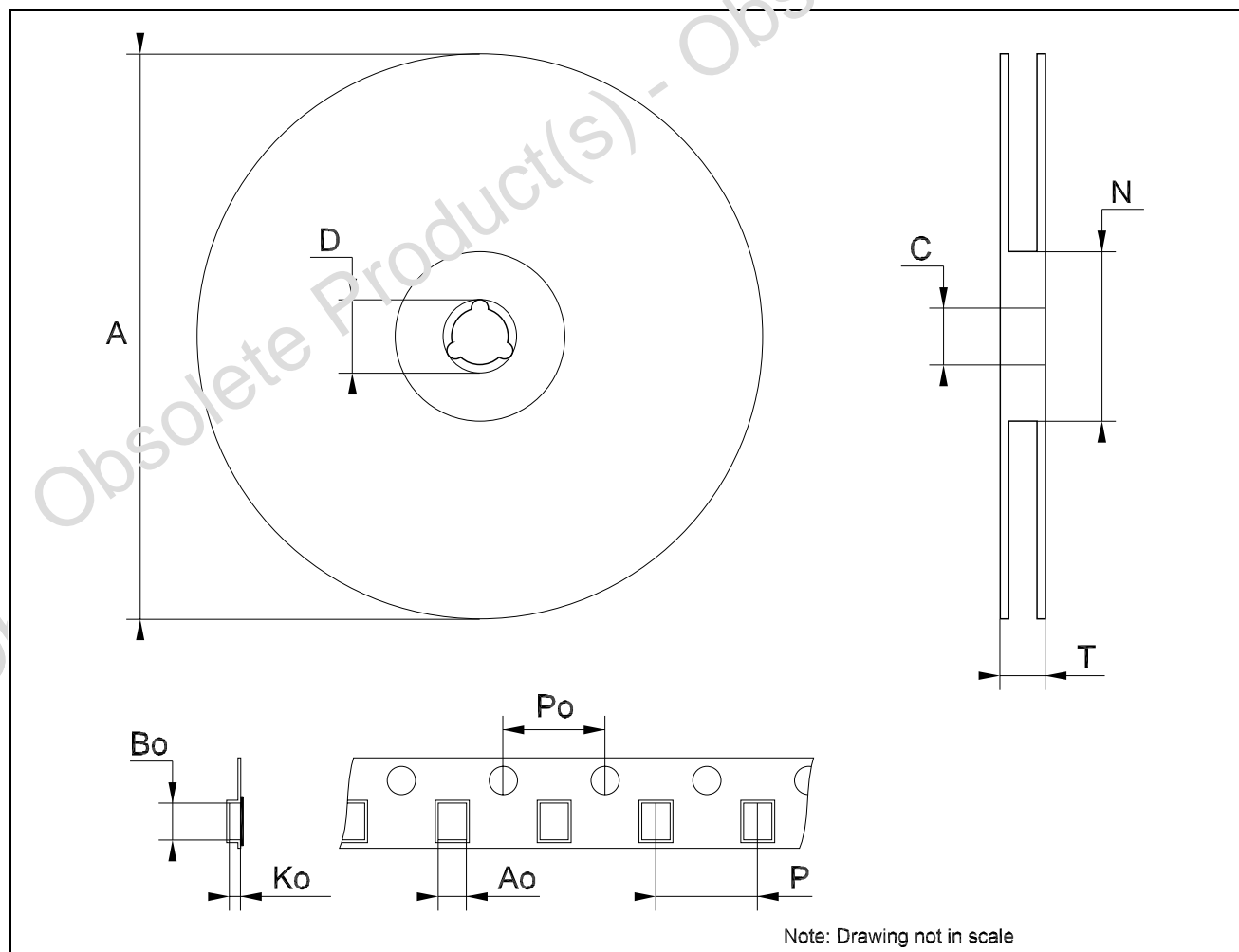

Table 10: Revision History

Date	Revision	Description of Changes
29-Jul-2004	2	Ordering Codes Revision - pag. 1.

Obsolete Product(s) - Obsolete Product(s)
Obsolete Product(s) - Obsolete Product(s)

Information furnished is believed to be accurate and reliable. However, STMicroelectronics assumes no responsibility for the consequences of use of such information nor for any infringement of patents or other rights of third parties which may result from its use. No license is granted by implication or otherwise under any patent or patent rights of STMicroelectronics. Specifications mentioned in this publication are subject to change without notice. This publication supersedes and replaces all information previously supplied. STMicroelectronics products are not authorized for use as critical components in life support devices or systems without express written approval of STMicroelectronics.

The ST logo is a registered trademark of STMicroelectronics

All other names are the property of their respective owners

© 2004 STMicroelectronics - All Rights Reserved

STMicroelectronics group of companies

Australia - Belgium - Brazil - Canada - China - Czech Republic - Finland - France - Germany - Hong Kong - India - Israel - Italy - Japan - Malaysia - Malta - Morocco - Singapore - Spain - Sweden - Switzerland - United Kingdom - United States of America

www.st.com

