

# MC74HC4538A

## Dual Precision Monostable Multivibrator (Retriggerable, Resettable)

The MC74HC4538A is identical in pinout to the MC14538B. The device inputs are compatible with standard CMOS outputs; with pullup resistors, they are compatible with LSTTL outputs.

This dual monostable multivibrator may be triggered by either the positive or the negative edge of an input pulse, and produces a precision output pulse over a wide range of pulse widths. Because the device has conditioned trigger inputs, there are no trigger-input rise and fall time restrictions. The output pulse width is determined by the external timing components,  $R_x$  and  $C_x$ . The device has a reset function which forces the Q output low and the  $\bar{Q}$  output high, regardless of the state of the output pulse circuitry.

### Features

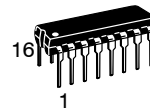
- Unlimited Rise and Fall Times Allowed on the Trigger Inputs
- Output Pulse is Independent of the Trigger Pulse Width
- $\pm 10\%$  Guaranteed Pulse Width Variation from Part to Part (Using the Same Test Jig)
- Output Drive Capability: 10 LSTTL Loads
- Outputs Directly Interface to CMOS, NMOS and TTL
- Operating Voltage Range: 3.0 to 6.0 V
- Low Input Current: 1.0  $\mu\text{A}$
- High Noise Immunity Characteristic of CMOS Devices
- In Compliance with the Requirements Defined by JEDEC Standard No. 7 A
- Chip Complexity: 145 FETs or 36 Equivalent Gates
- NLV Prefix for Automotive and Other Applications Requiring Unique Site and Control Change Requirements; AEC-Q100 Qualified and PPAP Capable
- These Devices are Pb-Free, Halogen Free and are RoHS Compliant



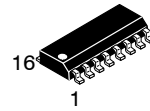
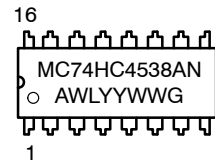
ON Semiconductor®

<http://onsemi.com>

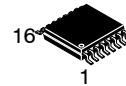
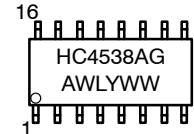
### MARKING DIAGRAMS



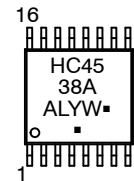
PDIP-16  
N SUFFIX  
CASE 648



SOIC-16  
D SUFFIX  
CASE 751B



TSSOP-16  
DT SUFFIX  
CASE 948F



A = Assembly Location  
L, WL = Wafer Lot  
Y, YY = Year  
W, WW = Work Week  
G or ▪ = Pb-Free Package

(Note: Microdot may be in either location)

### ORDERING INFORMATION

See detailed ordering and shipping information in the package dimensions section on page 2 of this data sheet.

# MC74HC4538A

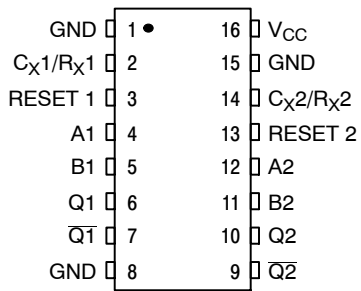


Figure 1. Pin Assignment

## FUNCTION TABLE

Inputs			Outputs	
Reset	A	B	Q	Q̄
H	↗	H	↗	↘
H	L	↘	↘	↗
H	X	L	Not Triggered	Not Triggered
H	H	X	Not Triggered	Not Triggered
H	L,H,↗	H	Not Triggered	Not Triggered
H	L	L,H,↘	Not Triggered	Not Triggered
L	X	X	L	H
↗↘	X	X	Not Triggered	Not Triggered

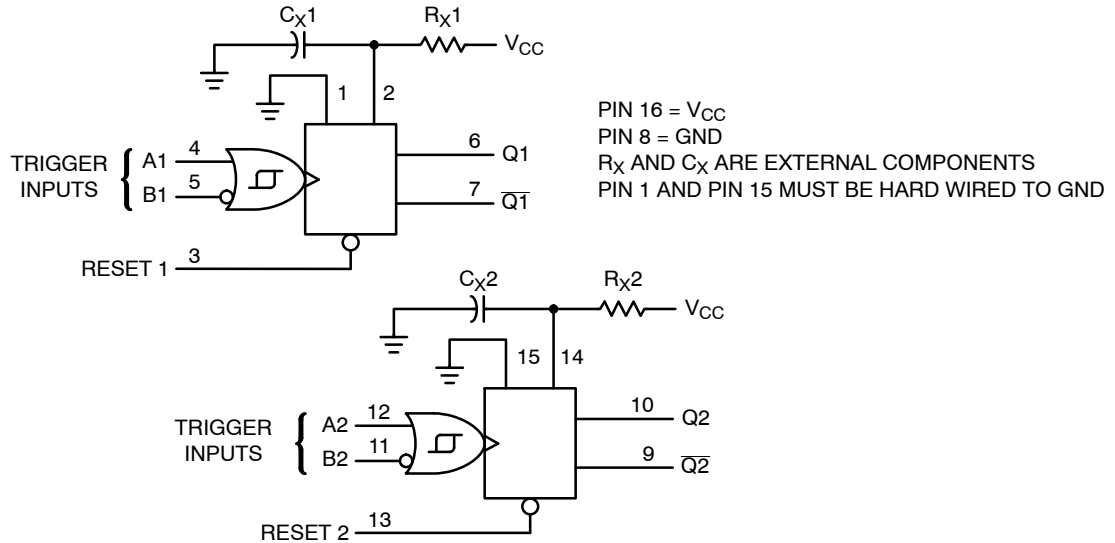


Figure 2. Logic Diagram

## ORDERING INFORMATION

Device	Package	Shipping†
MC74HC4538ANG	PDIP-16 (Pb-Free)	500 Units / Rail
MC74HC4538ADG	SOIC-16 (Pb-Free)	48 Units / Rail
MC74HC4538ADR2G	SOIC-16 (Pb-Free)	2500 / Tape & Reel
MC74HC4538ADTR2G	TSSOP-16 (Pb-Free)	2500 / Tape & Reel
NLV74HC4538ADR2G*	SOIC-16 (Pb-Free)	2500 / Tape & Reel
NLVHC4538ADTR2G*	TSSOP-16 (Pb-Free)	2500 / Tape & Reel

†For information on tape and reel specifications, including part orientation and tape sizes, please refer to our Tape and Reel Packaging Specifications Brochure, BRD8011/D.

\*NLV Prefix for Automotive and Other Applications Requiring Unique Site and Control Change Requirements; AEC-Q100 Qualified and PPAP Capable

# MC74HC4538A

## MAXIMUM RATINGS

Symbol	Parameter	Value	Unit
V <sub>CC</sub>	DC Supply Voltage	-0.5 to +7.0	V
V <sub>I</sub>	DC Input Voltage	-0.5 ≤ V <sub>I</sub> ≤ V <sub>CC</sub> + 0.5	V
V <sub>O</sub>	DC Output Voltage (Note 1)	-0.5 ≤ V <sub>O</sub> ≤ V <sub>CC</sub> + 0.5	V
I <sub>IK</sub>	DC Input Diode Current A, B, Reset C <sub>X</sub> , R <sub>X</sub>	±20 ±30	mA
I <sub>OK</sub>	DC Output Diode Current	±25	mA
I <sub>O</sub>	DC Output Sink Current	±25	mA
I <sub>CC</sub>	DC Supply Current per Supply Pin	±100	mA
I <sub>GND</sub>	DC Ground Current per Ground Pin	±100	mA
T <sub>STG</sub>	Storage Temperature Range	-65 to +150	°C
T <sub>L</sub>	Lead temperature, 1 mm from Case for 10 Seconds	260	°C
T <sub>J</sub>	Junction temperature under Bias	+150	°C
θ <sub>JA</sub>	Thermal resistance PDIP SOIC TSSOP	78 112 148	°C/W
P <sub>D</sub>	Power Dissipation in Still Air at 85°C PDIP SOIC TSSOP	750 500 450	mW
MSL	Moisture Sensitivity	Level 1	
F <sub>R</sub>	Flammability Rating Oxygen Index: 30% - 35%	UL-94-VO (0.125 in)	
V <sub>ESD</sub>	ESD Withstand Voltage Human Body Model (Note 2) Machine Model (Note 3) Charged Device Model (Note 4)	>2000 >100 >500	V
I <sub>Latchup</sub>	Latchup Performance Above V <sub>CC</sub> and Below GND at 85°C (Note 5)	±300	mA

Stresses exceeding Maximum Ratings may damage the device. Maximum Ratings are stress ratings only. Functional operation above the Recommended Operating Conditions is not implied. Extended exposure to stresses above the Recommended Operating Conditions may affect device reliability.

1. I<sub>O</sub> absolute maximum rating must be observed.
2. Tested to EIA/JESD22-A114-A.
3. Tested to EIA/JESD22-A115-A.
4. Tested to JESD22-C101-A.
5. Tested to EIA/JESD78.

## RECOMMENDED OPERATING CONDITIONS

Symbol	Parameter	Min	Max	Unit
V <sub>CC</sub>	DC Supply Voltage (Referenced to GND)	2.0	6.0	V
V <sub>in</sub> , V <sub>out</sub>	DC Input Voltage, Output Voltage (Referenced to GND)	0	V <sub>CC</sub>	V
T <sub>A</sub>	Operating Temperature, All Package Types	-55	+125	°C
t <sub>r</sub> , t <sub>f</sub>	Input Rise and Fall Time (Figure 7) A or B (Figure 5) V <sub>CC</sub> = 2.0 V V <sub>CC</sub> = 4.5 V V <sub>CC</sub> = 6.0 V	0 0 0 -	1000 500 400 No Limit	ns
R <sub>X</sub>	External Timing Resistor V <sub>CC</sub> < 4.5 V V <sub>CC</sub> ≥ 4.5 V	1.0 2.0	† †	kΩ
C <sub>X</sub>	External Timing Capacitor	0	†	μF

† The maximum allowable values of R<sub>X</sub> and C<sub>X</sub> are a function of the leakage of capacitor C<sub>X</sub>, the leakage of the HC4538A, and leakage due to board layout and surface resistance. For most applications, C<sub>X</sub>/R<sub>X</sub> should be limited to a maximum value of 10 μF/1.0 MΩ. Values of C<sub>X</sub> > 1.0 μF may cause a problem during power down (see Power Down Considerations). Susceptibility to externally induced noise signals may occur for R<sub>X</sub> > 1.0 MΩ.

6. Unused inputs may not be left open. All inputs must be tied to a high-logic voltage level or a low-logic input voltage level.

# MC74HC4538A

## DC CHARACTERISTICS

Symbol	Parameter	Test Conditions	V <sub>CC</sub> V	Guaranteed Limits									Unit
				-55 to 25°C			≤ 85°C			≤ 125°C			
				Min	Typ	Max	Min	Typ	Max	Min	Typ	Max	
V <sub>IH</sub>	Minimum High-Level Input Voltage	V <sub>out</sub> = 0.1 V or V <sub>CC</sub> - 0.1 V  I <sub>out</sub>   ≤ 20 μA	2.0 4.5 6.0	1.5 3.15 4.2			1.5 3.15 4.2			1.5 3.15 4.2			V
V <sub>IL</sub>	Maximum Low-Level Input Voltage	V <sub>out</sub> = 0.1 V or V <sub>CC</sub> - 0.1 V  I <sub>out</sub>   ≤ 20 μA	2.0 4.5 6.0			0.5 1.35 1.8			0.5 1.35 1.8			0.5 1.35 1.8	V
V <sub>OH</sub>	Minimum High-Level Output Voltage	V <sub>in</sub> = V <sub>IH</sub> or V <sub>IL</sub>  I <sub>out</sub>   ≤ 20 μA	2.0 4.5 6.0	1.9 4.4 5.9			1.9 4.4 5.9			1.9 4.4 5.9			V
		V <sub>in</sub> = V <sub>IH</sub> or V <sub>IL</sub>  I <sub>out</sub>   ≤ -4.0 mA  I <sub>out</sub>   ≤ -5.2 mA	4.5 6.0	3.98 5.48			3.84 5.34			3.7 5.2			
V <sub>OL</sub>	Maximum Low-Level Output Voltage	V <sub>in</sub> = V <sub>IH</sub> or V <sub>IL</sub>  I <sub>out</sub>   ≤ 20 μA	2.0 4.5 6.0			0.1 0.1 0.1			0.1 0.1 0.1			0.1 0.1 0.1	V
		V <sub>in</sub> = V <sub>IH</sub> or V <sub>IL</sub>  I <sub>out</sub>   ≤ 4.0 mA  I <sub>out</sub>   ≤ 5.2 mA	4.5 6.0			0.26 0.26			0.33 0.33			0.4 0.4	
I <sub>in</sub>	Maximum Input Leakage Current (A, B, Reset)	V <sub>in</sub> = V <sub>CC</sub> or GND	6.0			± 0.1			± 1.0			± 1.0	μA
I <sub>in</sub>	Maximum Input Leakage Current (R <sub>x</sub> , C <sub>x</sub> )	V <sub>in</sub> = V <sub>CC</sub> or GND	6.0			± 50			± 500			± 500	nA
I <sub>CC</sub>	Maximum Quiescent Supply Current (per package) Standby State	V <sub>in</sub> = V <sub>CC</sub> or GND Q1 and Q2 = Low I <sub>out</sub> = 0 μA	6.0			130			220			350	μA
I <sub>CC</sub>	Maximum Supply Current (per package) Active State	V <sub>in</sub> = V <sub>CC</sub> or GND Q1 and Q2 = High I <sub>out</sub> = 0 μA Pins 2 and 14 = 0.5 V <sub>CC</sub>	6.0	25°C			-45°C to 85°C			-55°C to 125°C			μA
					400			600				800	

# MC74HC4538A

## AC CHARACTERISTICS (C<sub>L</sub> = 50 pF, Input t<sub>r</sub> = t<sub>f</sub> = 6.0 ns)

Symbol	Parameter	V <sub>CC</sub> V	Guaranteed Limits						Unit
			-55 to 25°C		≤ 85°C		≤ 125°C		
			Min	Max	Min	Max	Min	Max	
t <sub>PLH</sub>	Maximum Propagation Delay Input A or B to Q (Figures 6 and 8)	2.0		175		220		265	ns
		4.5		35		44		53	
		6.0		30		37		45	
t <sub>PHL</sub>	Maximum Propagation Delay Input A or B to NQ (Figures 6 and 8)	2.0		195		245		295	ns
		4.5		39		49		59	
		6.0		33		42		50	
t <sub>PHL</sub>	Maximum Propagation Delay Reset to Q (Figures 7 and 8)	2.0		175		220		265	ns
		4.5		35		44		53	
		6.0		30		37		45	
t <sub>PLH</sub>	Maximum Propagation Delay Reset to NQ (Figures 7 and 8)	2.0		175		220		265	ns
		4.5		35		44		53	
		6.0		30		37		45	
t <sub>TLH</sub> , t <sub>THL</sub>	Maximum Output Transition Time, Any Output (Figures 7 and 8)	2.0		75		95		110	ns
		4.5		15		19		22	
		6.0		13		16		19	
C <sub>in</sub>	Maximum Input Capacitance (A, B, Reset) (C <sub>x</sub> , R <sub>x</sub> )	-		10 25		10 25		10 25	pF

C <sub>PD</sub>	Power Dissipation Capacitance (per Multivibrator)*	Typical @ 25°C, V <sub>CC</sub> = 5.0 V		pF
		150		

\*Used to determine the no-load dynamic power consumption: P<sub>D</sub> = C<sub>PD</sub> V<sub>CC</sub><sup>2</sup>f + I<sub>CC</sub> V<sub>CC</sub>.

## TIMING CHARACTERISTICS (Input t<sub>r</sub> = t<sub>f</sub> = 6.0 ns)

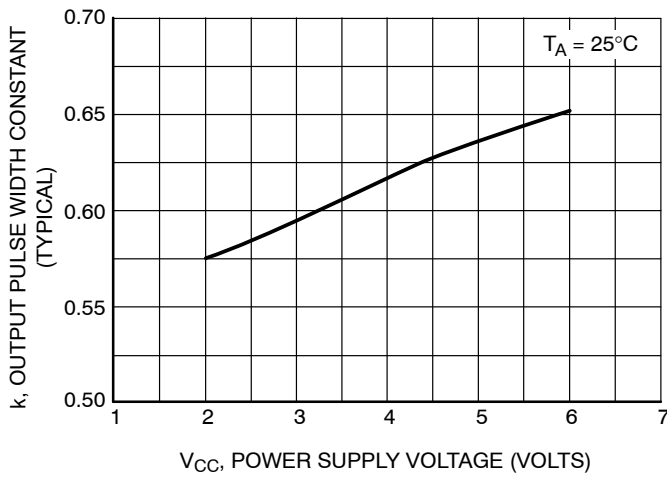
Symbol	Parameter	V <sub>CC</sub> V	Guaranteed Limits						Unit
			-55 to 25°C		≤ 85°C		≤ 125°C		
			Min	Max	Min	Max	Min	Max	
t <sub>rec</sub>	Minimum Recovery Time, Inactive to A or B (Figure 7)	2.0	0		0		0		ns
		4.5	0		0		0		
		6.0	0		0		0		
t <sub>w</sub>	Minimum Pulse Width, Input A or B (Figure 6)	2.0	60		75		90		ns
		4.5	12		15		18		
		6.0	10		13		15		
t <sub>w</sub>	Minimum Pulse Width, Reset (Figure 7)	2.0	60		75		90		ns
		4.5	12		15		18		
		6.0	10		13		15		
t <sub>r</sub> , t <sub>f</sub>	Maximum Input Rise and Fall Times, Reset (Figure 7)	2.0		1000		1000		1000	ns
		4.5		500		500		500	
		6.0		400		400		400	
	A or B (Figure 7)	2.0 4.5 6.0	No Limit						

# MC74HC4538A

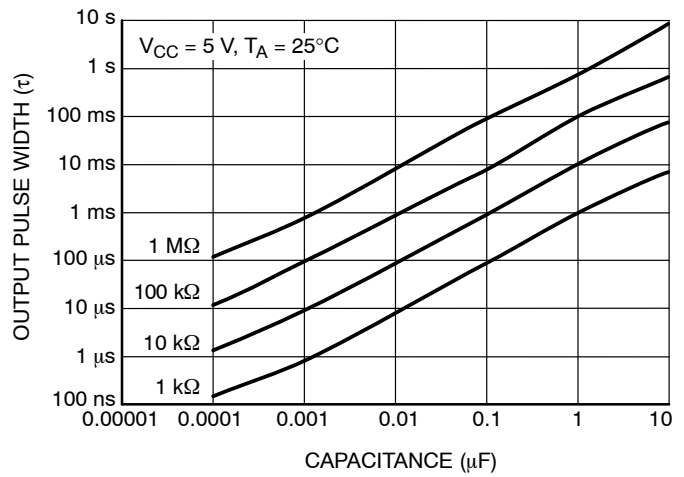
## OUTPUT PULSE WIDTH CHARACTERISTICS ( $C_L = 50 \text{ pF}$ )

Symbol	Parameter	Conditions		Guaranteed Limits						Unit
		Timing Components	$V_{CC}$ V	-55 to 25°C		≤ 85°C		≤ 125°C		
				Min	Max	Min	Max	Min	Max	
$\tau$	Output Pulse Width* (Figures 6 and 8)	$R_x = 10 \text{ k}\Omega$ , $C_x = 0.1 \text{ }\mu\text{F}$	5.0	0.63	0.77	0.6	0.8	0.59	0.81	ms
-	Pulse Width Match Between Circuits in the same Package	-	-	± 5.0						%
-	Pulse Width Match Variation (Part to Part)	-	-	± 10						%

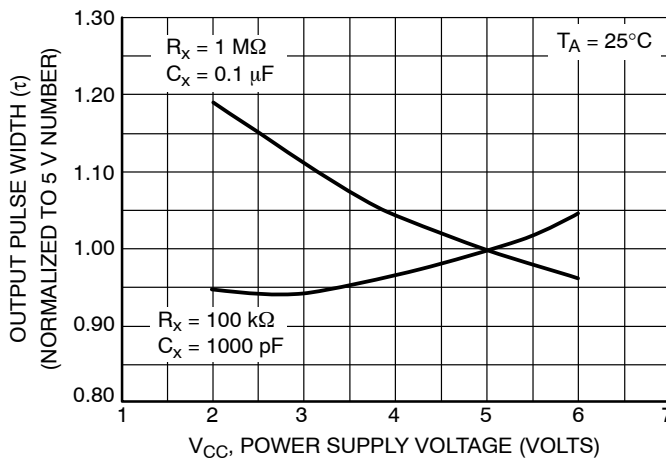
\*For output pulse widths greater than 100  $\mu\text{s}$ , typically  $\tau = kR_xC_x$ , where the value of k may be found in Figure 3.



**Figure 3. Typical Output Pulse Width Constant, k, versus Supply Voltage**  
(For output pulse widths > 100  $\mu\text{s}$ :  $\tau = kR_xC_x$ )

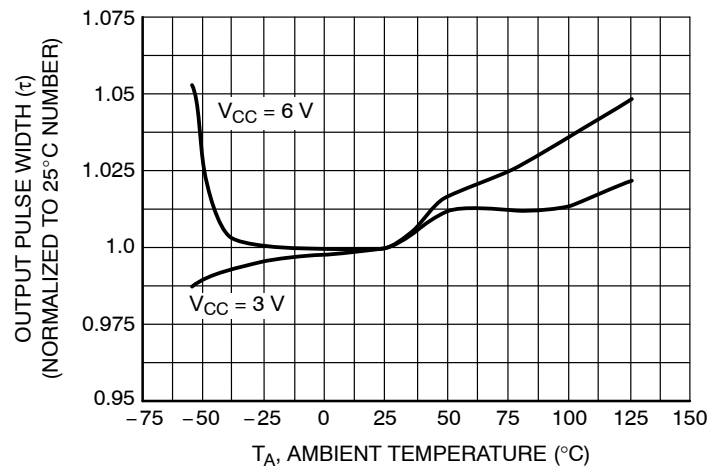


**Figure 4. Output Pulse Width versus Timing Capacitance**

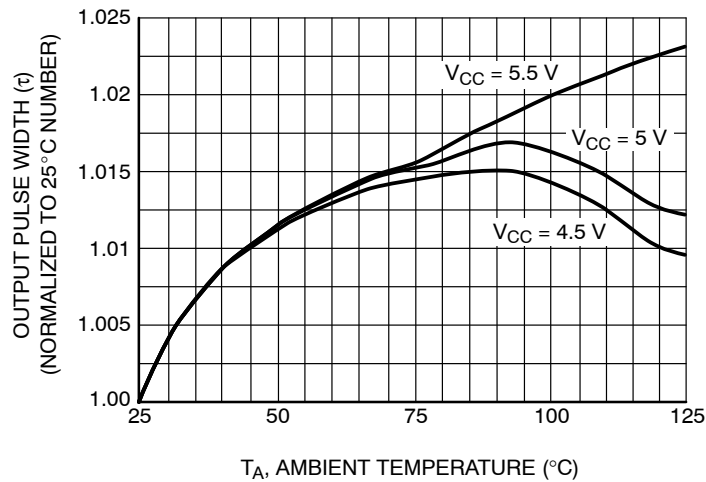


**Figure 5. Normalized Output Pulse Width versus Power Supply Voltage**

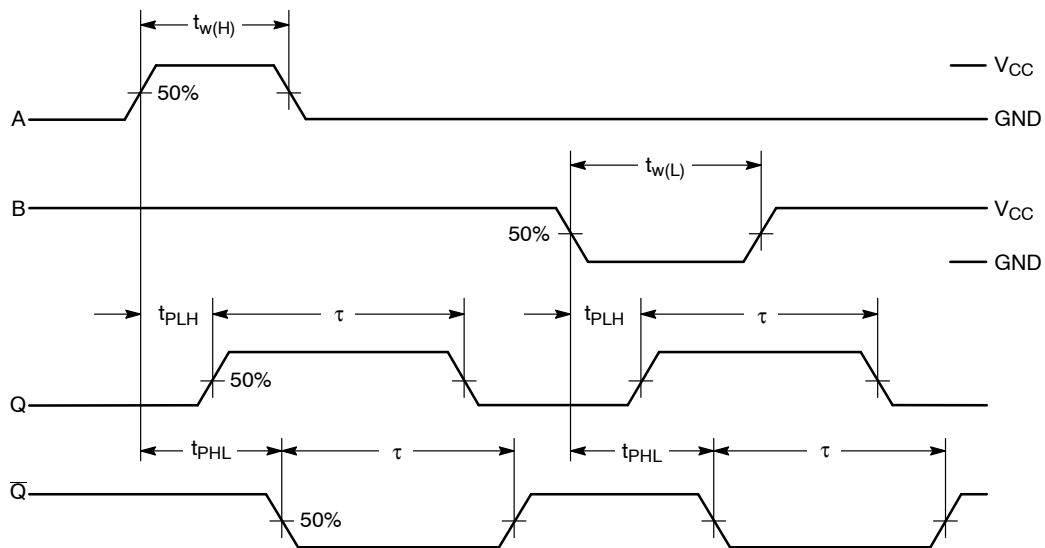
# MC74HC4538A



**Figure 6. Normalized Output Pulse Width versus Power Supply Voltage**



**Figure 7. Normalized Output Pulse Width versus Power Supply Voltage**



**Figure 8. Switching Waveform**

# MC74HC4538A

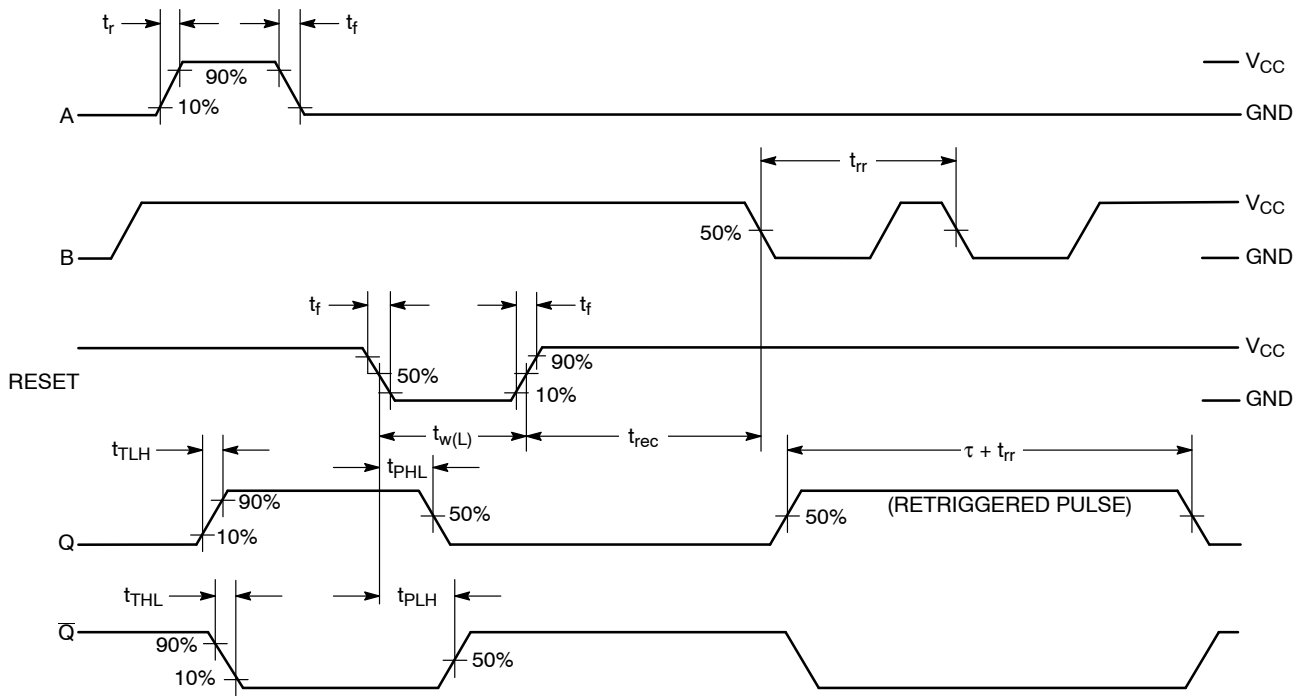
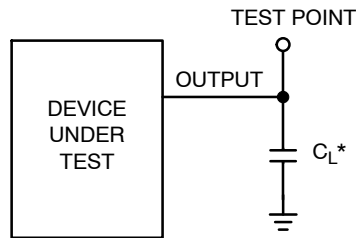


Figure 9. Switching Waveform



\*Includes all probe and jig capacitance

Figure 10. Test Circuit



# MC74HC4538A

## PIN DESCRIPTIONS

### INPUTS

#### A1, A2 (Pins 4, 12)

Positive-edge trigger inputs. A rising-edge signal on either of these pins triggers the corresponding multivibrator when there is a high level on the B1 or B2 input.

#### B1, B2 (Pins 5, 11)

Negative-edge trigger inputs. A falling-edge signal on either of these pins triggers the corresponding multivibrator when there is a low level on the A1 or A2 input.

#### Reset 1, Reset 2 (Pins 3, 13)

Reset inputs (active low). When a low level is applied to one of these pins, the Q output of the corresponding multivibrator is reset to a low level and the  $\bar{Q}$  output is set to a high level.

#### C<sub>X1</sub>/R<sub>X1</sub> and C<sub>X2</sub>/R<sub>X2</sub> (Pins 2 and 14)

External timing components. These pins are tied to the common points of the external timing resistors and

capacitors (see the Block Diagram). Polystyrene capacitors are recommended for optimum pulse width control. Electrolytic capacitors are not recommended due to high leakages associated with these type capacitors.

#### GND (Pins 1 and 15)

External ground. The external timing capacitors discharge to ground through these pins.

### OUTPUTS

#### Q1, Q2 (Pins 6, 10)

Noninverted monostable outputs. These pins (normally low) pulse high when the multivibrator is triggered at either the A or the B input. The width of the pulse is determined by the external timing components, R<sub>X</sub> and C<sub>X</sub>.

#### $\bar{Q}1, \bar{Q}2$ (Pins 7, 9)

Inverted monostable outputs. These pins (normally high) pulse low when the multivibrator is triggered at either the A or the B input. These outputs are the inverse of Q1 and Q2.

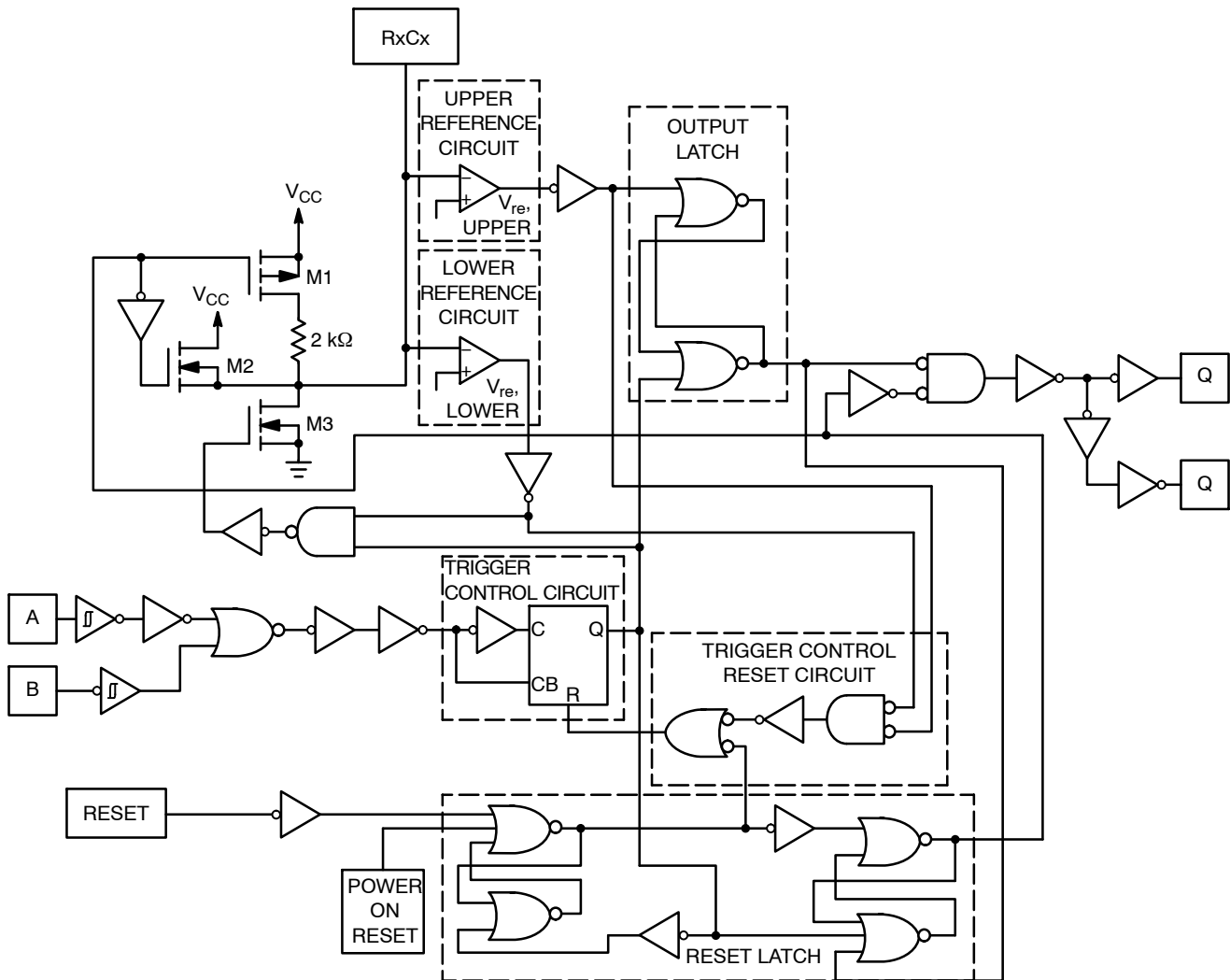


Figure 11. Logic Detail (1/2 the Device)

CIRCUIT OPERATION

Figure 12 shows the HC4538A configured in the retriggerable mode. Briefly, the device operates as follows (refer to Figure 10): In the quiescent state, the external timing capacitor,  $C_x$ , is charged to  $V_{CC}$ . When a trigger occurs, the Q output goes high and  $C_x$  discharges quickly to the lower reference voltage ( $V_{ref\ Lower} \approx 1/3 V_{CC}$ ).  $C_x$  then charges, through  $R_x$ , back up to the upper reference voltage ( $V_{ref\ Upper} \approx 2/3 V_{CC}$ ), at which point the one-shot has timed out and the Q output goes low.

The following, more detailed description of the circuit operation refers to both the logic detail (Figure 9) and the timing diagram (Figure 10).

QUIESCENT STATE

In the quiescent state, before an input trigger appears, the output latch is high and the reset latch is high (#1 in Figure 10). Thus the Q output (pin 6 or 10) of the monostable multivibrator is low (#2, Figure 10).

The output of the trigger-control circuit is low (#3), and transistors M1, M2, and M3 are turned off. The external timing capacitor,  $C_x$ , is charged to  $V_{CC}$  (#4), and both the upper and lower reference circuit has a low output (#5).

In addition, the output of the trigger-control reset circuit is low.

TRIGGER OPERATION

The HC4538A is triggered by either a rising-edge signal at input A (#7) or a falling-edge signal at input B (#8), with the unused trigger input and the Reset input held at the voltage levels shown in the Function Table. Either trigger signal will cause the output of the trigger-control circuit to go high (#9).

The trigger-control circuit going high simultaneously initiates two events. First, the output latch goes low, thus taking the Q output of the HC4538A to a high state (#10). Second, transistor M3 is turned on, which allows the external timing capacitor,  $C_x$ , to rapidly discharge toward ground (#11). (Note that the voltage across  $C_x$  appears at the input of both the upper and lower reference circuit comparator).

When  $C_x$  discharges to the reference voltage of the lower reference circuit (#12), the outputs of both reference circuits will be high (#13). The trigger-control reset circuit goes high, resetting the trigger-control circuit flip-flop to a low state (#14). This turns transistor M3 off again, allowing  $C_x$  to begin to charge back up toward  $V_{CC}$ , with a time constant  $t = R_x C_x$  (#15). Once the voltage across  $C_x$  charges to above the lower reference voltage, the lower reference circuit will go low allowing the monostable multivibrator to be retriggered.

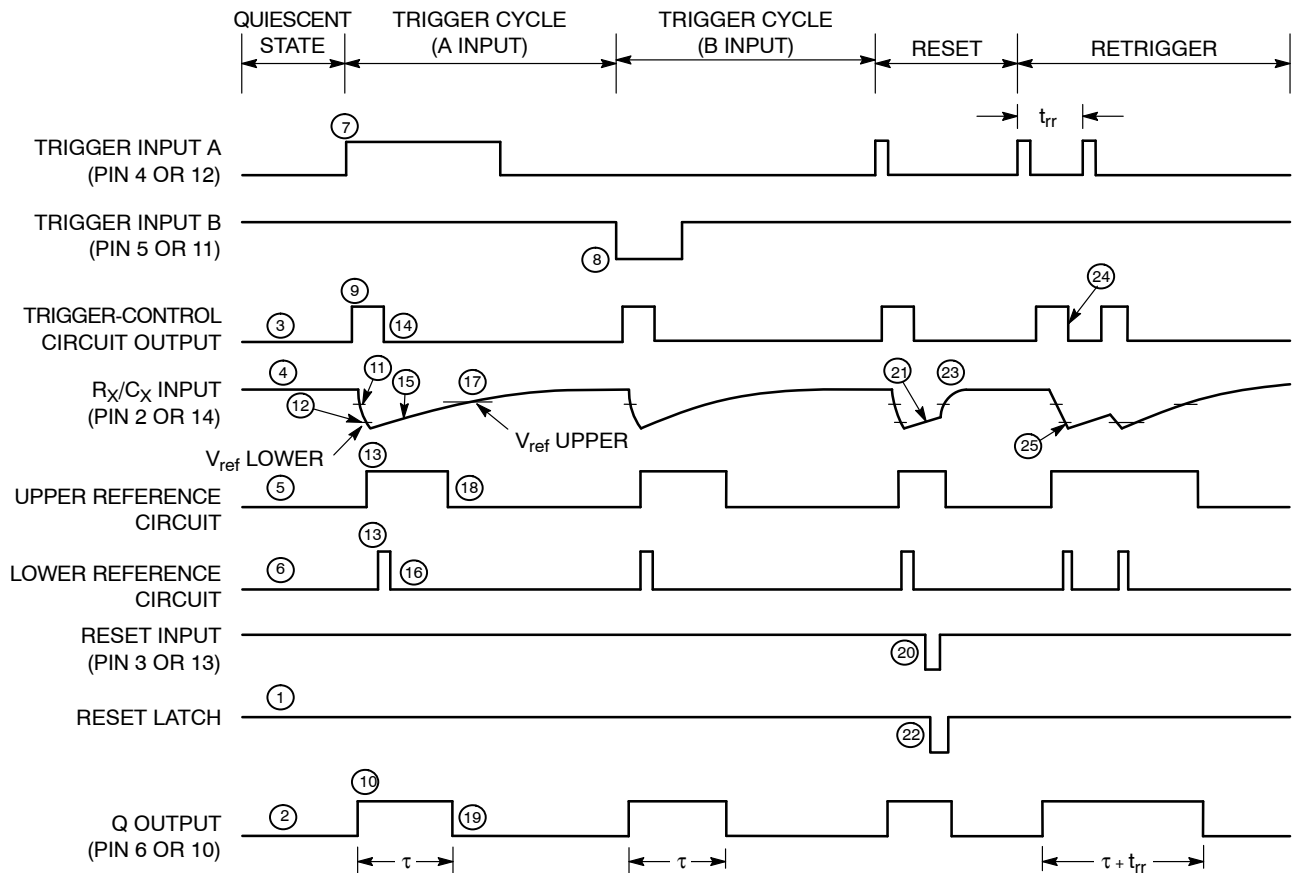


Figure 12. Timing Diagram

## MC74HC4538A

When  $C_x$  charges up to the reference voltage of the upper reference circuit (#17), the output of the upper reference circuit goes low (#18). This causes the output latch to toggle, taking the Q output of the HC4538A to a low state (#19), and completing the time-out cycle.

### POWER-DOWN CONSIDERATIONS

Large values of  $C_x$  may cause problems when powering down the HC4538A because of the amount of energy stored in the capacitor. When a system containing this device is powered down, the capacitor may discharge from  $V_{CC}$  through the input protection diodes at pin 2 or pin 14. Current through the protection diodes must be limited to 30 mA; therefore, the turn-off time of the  $V_{CC}$  power supply must not be faster than  $t = V_{CC} \bullet C_x / (30 \text{ mA})$ . For example, if  $V_{CC} = 5.0 \text{ V}$  and  $C_x = 15 \mu\text{F}$ , the  $V_{CC}$  supply must turn off no faster than  $t = (5.0 \text{ V}) \bullet (15 \mu\text{F}) / 30 \text{ mA} = 2.5 \text{ ms}$ . This is usually not a problem because power supplies are heavily filtered and cannot discharge at this rate.

When a more rapid decrease of  $V_{CC}$  to zero volts occurs, the HC4538A may sustain damage. To avoid this possibility, use an external damping diode,  $D_x$ , connected as shown in Figure 11. Best results can be achieved if diode  $D_x$  is chosen to be a germanium or Schottky type diode able to withstand large current surges.

### RESET AND POWER ON RESET OPERATION

A low voltage applied to the Reset pin always forces the Q output of the HC4538A to a low state.

The timing diagram illustrates the case in which reset occurs (#20) while  $C_x$  is charging up toward the reference voltage of the upper reference circuit (#21). When a reset

occurs, the output of the reset latch goes low (#22), turning on transistor M1. Thus  $C_x$  is allowed to quickly charge up to  $V_{CC}$  (#23) to await the next trigger signal.

On power up of the HC4538A the power-on reset circuit will be high causing a reset condition. This will prevent the trigger-control circuit from accepting a trigger input during this state. The HC4538A's Q outputs are low and the  $\bar{Q}$  not outputs are high.

### RETRIGGER OPERATION

When used in the retriggerable mode (Figure 12), the HC4538A may be retriggered during timing out of the output pulse at any time after the trigger-control circuit flip-flop has been reset (#24), and the voltage across  $C_x$  is above the lower reference voltage. As long as the  $C_x$  voltage is below the lower reference voltage, the reset of the flip-flop is high, disabling any trigger pulse. This prevents M3 from turning on during this period resulting in an output pulse width that is predictable.

The amount of undershoot voltage on  $R_x C_x$  during the trigger mode is a function of loop delay, M3 conductivity, and  $V_{DD}$ . Minimum retrigger time,  $t_{rr}$  (Figure 7), is a function of 1) time to discharge  $R_x C_x$  from  $V_{DD}$  to lower reference voltage ( $T_{\text{discharge}}$ ); 2) loop delay ( $T_{\text{delay}}$ ); 3) time to charge  $R_x C_x$  from the undershoot voltage back to the lower reference voltage ( $T_{\text{charge}}$ ).

Figure 13 shows the device configured in the non-retriggerable mode.

For additional information, please see Application Note (AN1558/D) titled *Characterization of Retrigger Time in the HC4538A Dual Precision Monostable Multivibrator*.

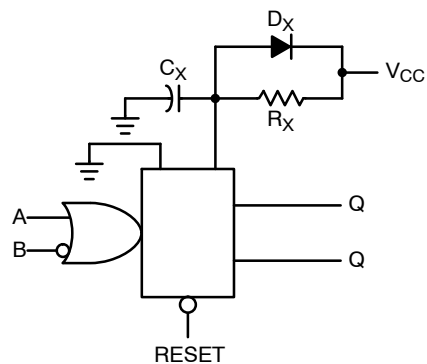


Figure 13. Discharge Protection During Power Down

# MC74HC4538A

## TYPICAL APPLICATIONS

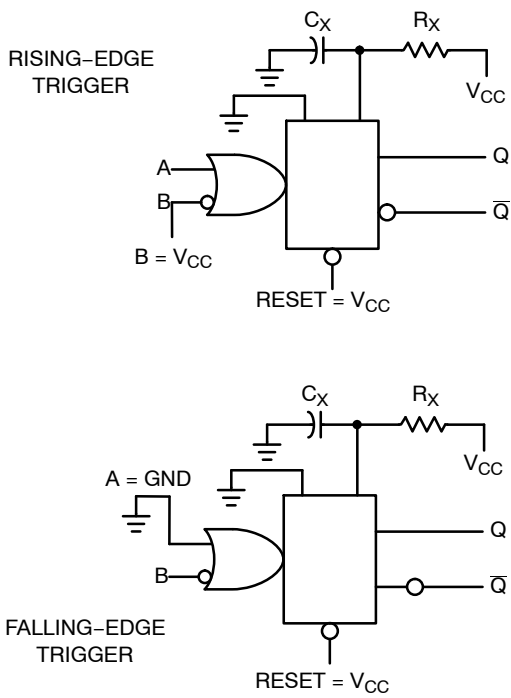


Figure 14. Retriggerable Monostable Circuitry

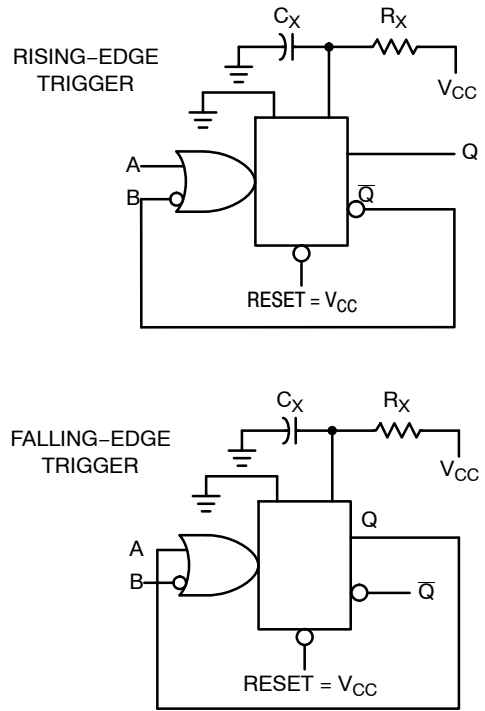


Figure 15. Non-retriggerable Monostable Circuitry

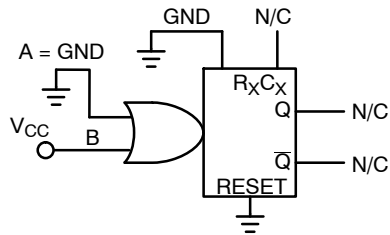
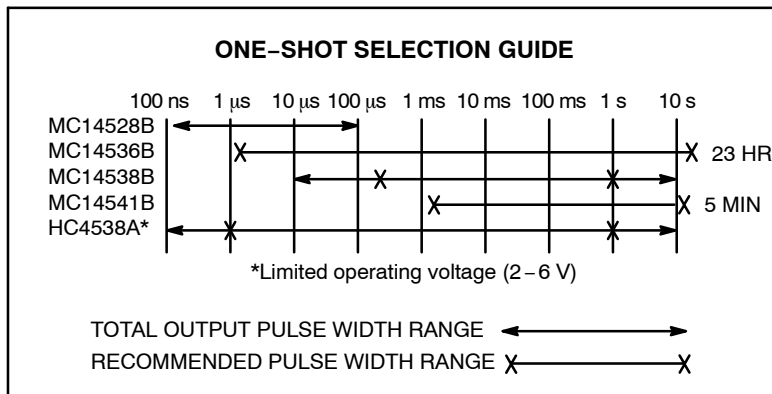


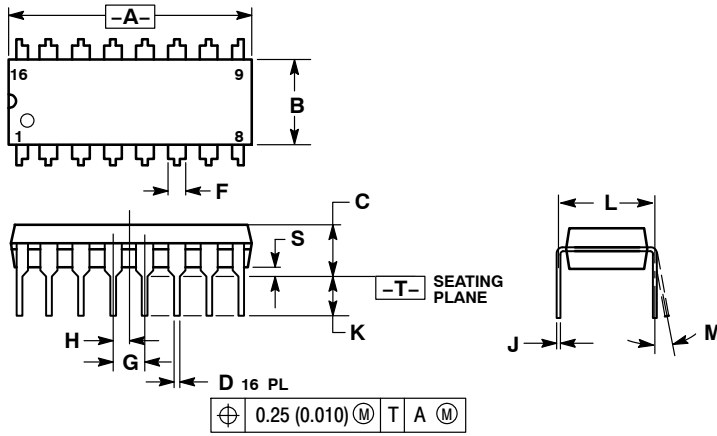
Figure 16. Connection of Unused Section



# MC74HC4538A

## PACKAGE DIMENSIONS

PDIP-16  
CASE 648-08  
ISSUE T



NOTES:

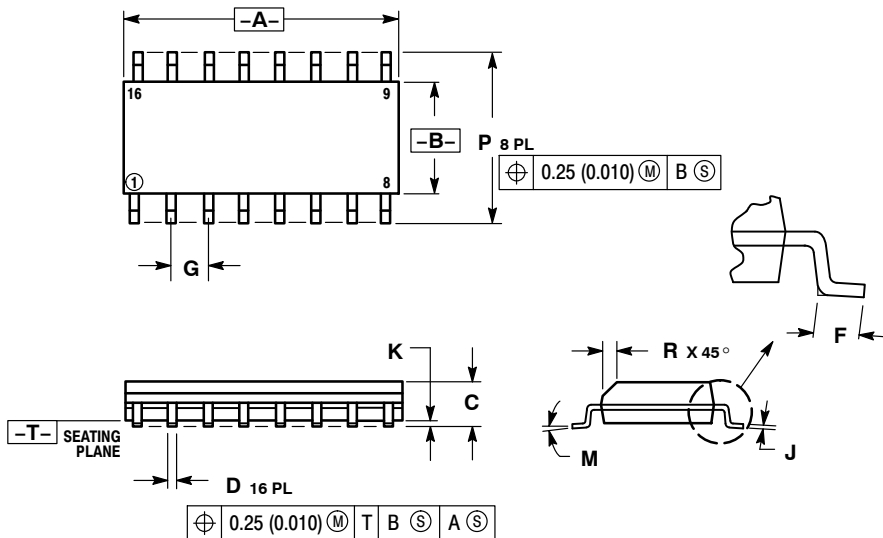
1. DIMENSIONING AND TOLERANCING PER ANSI Y14.5M, 1982.
2. CONTROLLING DIMENSION: INCH.
3. DIMENSION L TO CENTER OF LEADS WHEN FORMED PARALLEL.
4. DIMENSION B DOES NOT INCLUDE MOLD FLASH.
5. ROUNDED CORNERS OPTIONAL.

DIM	INCHES		MILLIMETERS	
	MIN	MAX	MIN	MAX
A	0.740	0.770	18.80	19.55
B	0.250	0.270	6.35	6.85
C	0.145	0.175	3.69	4.44
D	0.015	0.021	0.39	0.53
F	0.040	0.70	1.02	1.77
G	0.100 BSC		2.54 BSC	
H	0.050 BSC		1.27 BSC	
J	0.008	0.015	0.21	0.38
K	0.110	0.130	2.80	3.30
L	0.295	0.305	7.50	7.74
M	0° 10°		0° 10°	
S	0.020	0.040	0.51	1.01

# MC74HC4538A

## PACKAGE DIMENSIONS

SOIC-16  
CASE 751B-05  
ISSUE K

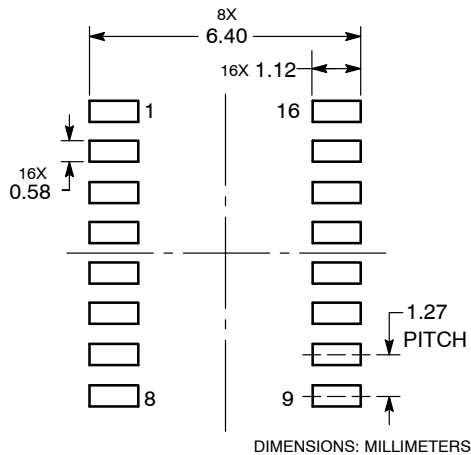


**NOTES:**

1. DIMENSIONING AND TOLERANCING PER ANSI Y14.5M, 1982.
2. CONTROLLING DIMENSION: MILLIMETER.
3. DIMENSIONS A AND B DO NOT INCLUDE MOLD PROTRUSION.
4. MAXIMUM MOLD PROTRUSION 0.15 (0.006) PER SIDE.
5. DIMENSION D DOES NOT INCLUDE DAMBAR PROTRUSION. ALLOWABLE DAMBAR PROTRUSION SHALL BE 0.127 (0.005) TOTAL IN EXCESS OF THE D DIMENSION AT MAXIMUM MATERIAL CONDITION.

DIM	MILLIMETERS		INCHES	
	MIN	MAX	MIN	MAX
A	9.80	10.00	0.386	0.393
B	3.80	4.00	0.150	0.157
C	1.35	1.75	0.054	0.068
D	0.35	0.49	0.014	0.019
F	0.40	1.25	0.016	0.049
G	1.27 BSC		0.050 BSC	
J	0.19	0.25	0.008	0.009
K	0.10	0.25	0.004	0.009
M	0°	7°	0°	7°
P	5.80	6.20	0.229	0.244
R	0.25	0.50	0.010	0.019

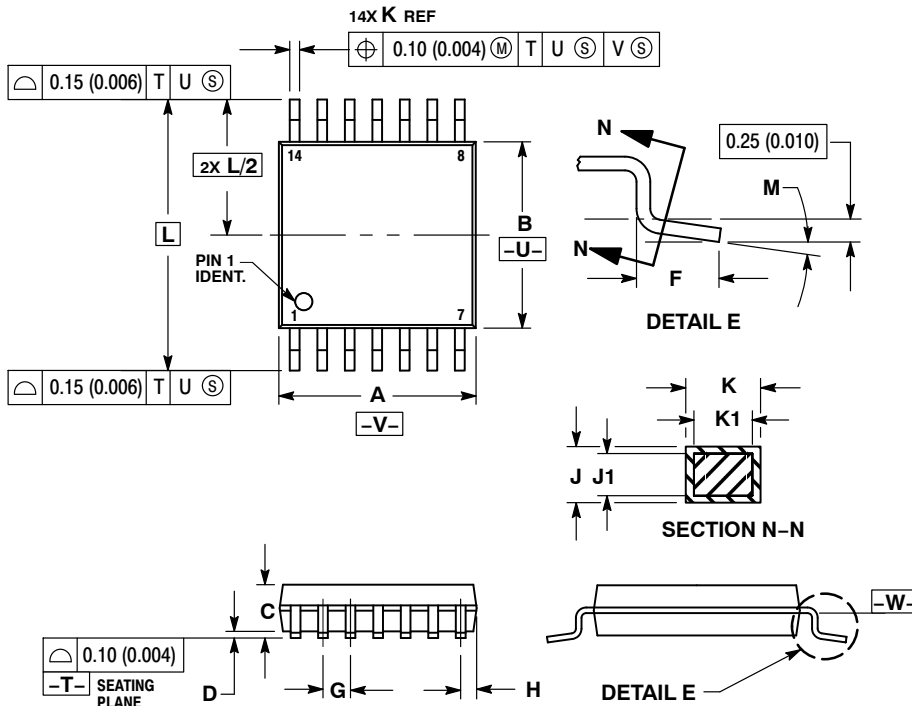
### SOLDERING FOOTPRINT



# MC74HC4538A

## PACKAGE DIMENSIONS

TSSOP-14  
DT SUFFIX  
CASE 948G-01  
ISSUE B

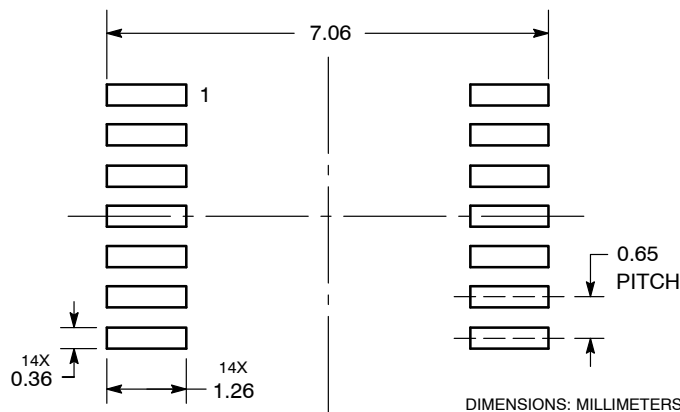


NOTES:

1. DIMENSIONING AND TOLERANCING PER ANSI Y14.5M, 1982.
2. CONTROLLING DIMENSION: MILLIMETER.
3. DIMENSION A DOES NOT INCLUDE MOLD FLASH, PROTRUSIONS OR GATE BURRS. MOLD FLASH OR GATE BURRS SHALL NOT EXCEED 0.15 (0.006) PER SIDE.
4. DIMENSION B DOES NOT INCLUDE INTERLEAD FLASH OR PROTRUSION. INTERLEAD FLASH OR PROTRUSION SHALL NOT EXCEED 0.25 (0.010) PER SIDE.
5. DIMENSION K DOES NOT INCLUDE DAMBAR PROTRUSION. ALLOWABLE DAMBAR PROTRUSION SHALL BE 0.08 (0.003) TOTAL IN EXCESS OF THE K DIMENSION AT MAXIMUM MATERIAL CONDITION.
6. TERMINAL NUMBERS ARE SHOWN FOR REFERENCE ONLY.
7. DIMENSION A AND B ARE TO BE DETERMINED AT DATUM PLANE -W-.

DIM	MILLIMETERS		INCHES	
	MIN	MAX	MIN	MAX
A	4.90	5.10	0.193	0.200
B	4.30	4.50	0.169	0.177
C	---	1.20	---	0.047
D	0.05	0.15	0.002	0.006
F	0.50	0.75	0.020	0.030
G	0.65 BSC		0.026 BSC	
H	0.50	0.60	0.020	0.024
J	0.09	0.20	0.004	0.008
J1	0.09	0.16	0.004	0.006
K	0.19	0.30	0.007	0.012
K1	0.19	0.25	0.007	0.010
L	6.40 BSC		0.252 BSC	
M	0°	8°	0°	8°

### SOLDERING FOOTPRINT\*



\*For additional information on our Pb-Free strategy and soldering details, please download the ON Semiconductor Soldering and Mounting Techniques Reference Manual, SOLDERRM/D.

# MC74HC4538A

**ON Semiconductor** and **ON** are registered trademarks of Semiconductor Components Industries, LLC (SCILLC). SCILLC reserves the right to make changes without further notice to any products herein. SCILLC makes no warranty, representation or guarantee regarding the suitability of its products for any particular purpose, nor does SCILLC assume any liability arising out of the application or use of any product or circuit, and specifically disclaims any and all liability, including without limitation special, consequential or incidental damages. "Typical" parameters which may be provided in SCILLC data sheets and/or specifications can and do vary in different applications and actual performance may vary over time. All operating parameters, including "Typicals" must be validated for each customer application by customer's technical experts. SCILLC does not convey any license under its patent rights nor the rights of others. SCILLC products are not designed, intended, or authorized for use as components in systems intended for surgical implant into the body, or other applications intended to support or sustain life, or for any other application in which the failure of the SCILLC product could create a situation where personal injury or death may occur. Should Buyer purchase or use SCILLC products for any such unintended or unauthorized application, Buyer shall indemnify and hold SCILLC and its officers, employees, subsidiaries, affiliates, and distributors harmless against all claims, costs, damages, and expenses, and reasonable attorney fees arising out of, directly or indirectly, any claim of personal injury or death associated with such unintended or unauthorized use, even if such claim alleges that SCILLC was negligent regarding the design or manufacture of the part. SCILLC is an Equal Opportunity/Affirmative Action Employer. This literature is subject to all applicable copyright laws and is not for resale in any manner.

## PUBLICATION ORDERING INFORMATION

### LITERATURE FULFILLMENT:

Literature Distribution Center for ON Semiconductor  
P.O. Box 5163, Denver, Colorado 80217 USA  
**Phone:** 303-675-2175 or 800-344-3860 Toll Free USA/Canada  
**Fax:** 303-675-2176 or 800-344-3867 Toll Free USA/Canada  
**Email:** [orderlit@onsemi.com](mailto:orderlit@onsemi.com)

**N. American Technical Support:** 800-282-9855 Toll Free  
USA/Canada  
**Europe, Middle East and Africa Technical Support:**  
Phone: 421 33 790 2910  
**Japan Customer Focus Center**  
Phone: 81-3-5817-1050

**ON Semiconductor Website:** [www.onsemi.com](http://www.onsemi.com)  
**Order Literature:** <http://www.onsemi.com/orderlit>  
For additional information, please contact your local  
Sales Representative

**MC74HC4538A/D**