

# Future Technology Devices International Ltd.

## FT311D (USB Android Host IC)

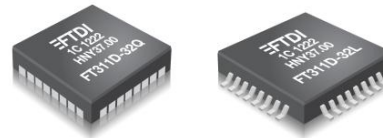

The FT311D is a Full Speed USB host specifically targeted at providing access to peripheral hardware from an Android platform with a USB device port. The device will bridge the USB port to six user selectable interface types and has the following advanced features:



- Single chip USB to selectable interface.
- Entire USB protocol handled on the chip. No USB specific firmware programming required.
- Interface options selectable via 3 mode select pins.
- 7 GPIO lines interface option
- Basic UART interface with RXD, TXD, RTS, CTS pins option.
- TX\_ACTIVE signal for controlling transceivers on RS485 interfaces.
- 4 PWM channels option.
- I<sup>2</sup>C master interface option.
- SPI Slave interface option supporting modes 0, 1, 2 and 3 with MSB/LSB options
- SPI Master interface option supporting modes 0, 1, 2 and 3 with MSB/LSB options.
- USB error indicator pin
- Suitable for use on any Android platform supporting Android Open Accessory Mode (Typically 3.1 onwards, however some platforms may port Open Accessory Mode to version 2.3.4)
- 12MHz oscillator using external crystal.
- Integrated power-on-reset circuit.
- +3V3 Single Supply Operation with 5V tolerant inputs.
- USB 2.0 Full Speed compatible.
- Extended operating temperature range; -40°C to 85°C.
- Available in compact Pb-free 32 Pin LQFP and QFN packages (both RoHS compliant).

Neither the whole nor any part of the information contained in, or the product described in this manual, may be adapted or reproduced in any material or electronic form without the prior written consent of the copyright holder. This product and its documentation are supplied on an as-is basis and no warranty as to their suitability for any particular purpose is either made or implied. Future Technology Devices International Ltd will not accept any claim for damages howsoever arising as a result of use or failure of this product. Your statutory rights are not affected. This product or any variant of it is not intended for use in any medical appliance, device or system in which the failure of the product might reasonably be expected to result in personal injury. This document provides preliminary information that may be subject to change without notice. No freedom to use patents or other intellectual property rights is implied by the publication of this document. Future Technology Devices International Ltd, Unit 1, 2 Seaward Place, Centurion Business Park, Glasgow G41 1HH United Kingdom. Scotland Registered Company Number: SC136640

## 1 Typical Applications

- Connecting Android phones to USB accessories
- Connecting Android tablets to USB accessories
- Controlling instrumentation from Android devices.
- Home automation via Android devices
- Data logging from USB accessories
- Connecting serial printing devices to Android devices

### 1.1 Part Numbers

Part Number	Package
FT311D-32Q1C-x	32 Pin QFN
FT311D-32L1C-x	32 Pin LQFP

Note: Packing codes for x is:

- R: Taped and Reel, QFN 3,000pcs per reel, LQFP 1500 pcs per reel.
  - (no suffix): Tray packing, 260pcs per tray QFN, 250 pcs per tray LQFP
- For example: FT311D-32Q1C-R is 3,000pcs QFN taped and reel packing

### 1.2 USB Compliant

At the time of writing this datasheet, the FT311D was still to complete USB compliancy testing.

## 2 FT311D Block Diagram

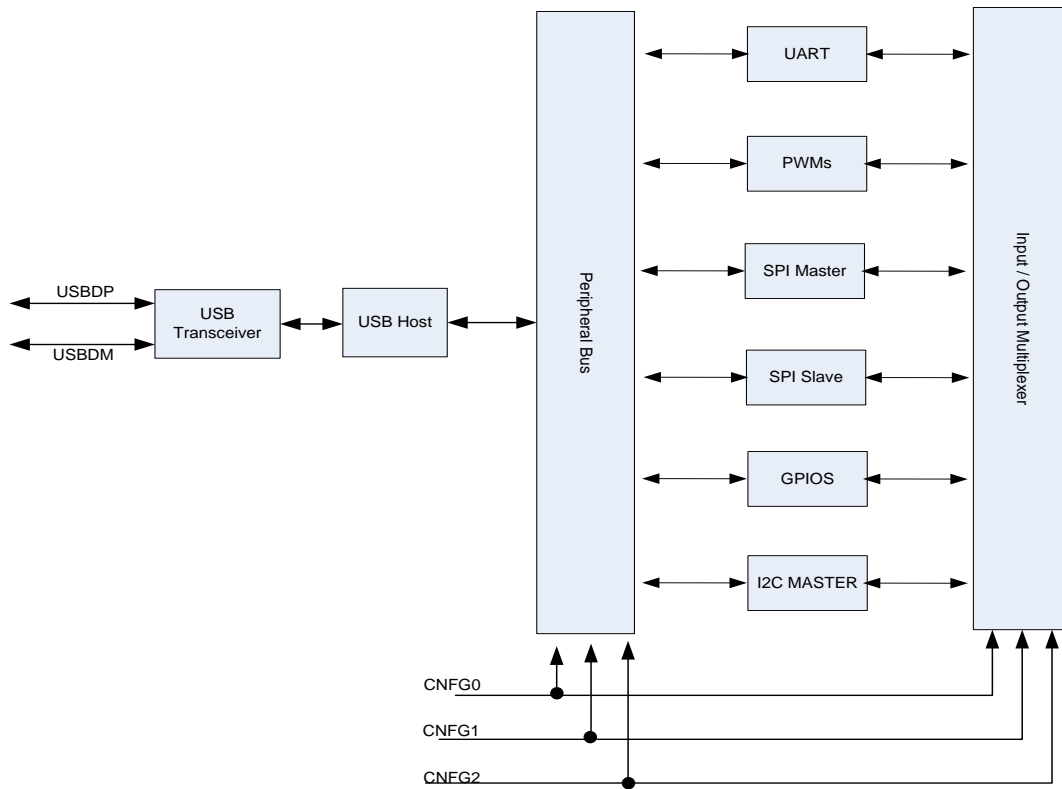

**Figure 2.1 FT311D Block Diagram**

For a description of each function please refer to Section 4.

**Table of Contents**

**1 Typical Applications..... 2**

**1.1 Part Numbers..... 2**

**1.2 USB Compliant ..... 2**

**2 FT311D Block Diagram ..... 3**

**3 Device Pin Out and Signal Description ..... 6**

**3.1 Package Symbol..... 6**

        3.1.1 Package PinOut Description .....6

**3.2 Interface Selection ..... 8**

        3.2.1 Interface pinout.....8

**4 Function Description..... 10**

**4.1 Key Features..... 10**

**4.2 Functional Block Descriptions ..... 10**

        4.2.1 Peripheral Interface Modules ..... 10

        4.2.2 USB Transceivers..... 10

        4.2.3 USB Host ..... 10

**4.3 I/O Peripherals Signal Names ..... 10**

**4.4 Default Mode Strings ..... 11**

**5 Peripheral Interfaces ..... 12**

**5.1 General Purpose Input Output..... 12**

**5.2 UART Interface ..... 12**

        5.2.1 UART Mode Signal Descriptions ..... 13

**5.3 Pulse Width Modulation ..... 13**

**5.4 I2C..... 13**

**5.5 Serial Peripheral Interface – SPI Modes ..... 14**

        5.5.1 SPI Clock Phase Modes ..... 14

        5.5.2 Serial Peripheral Interface – Slave ..... 16

        5.5.3 Serial Peripheral Interface – SPI Master..... 16

**6 USB Error Detection..... 19**

**7 Absolute Maximum Ratings ..... 20**

**7.1 DC Characteristics..... 20**

**7.2 ESD and Latch-up Specifications..... 22**

**8 Application Examples ..... 23**

**8.1 USB to GPIO Converter ..... 23**

**8.2 USB to UART Converter ..... 24**

**8.3 USB to PWM Converter ..... 25**

**8.4 USB to I<sup>2</sup>C (Master) Converter ..... 26**

---

<b>8.5</b>	<b>USB to SPI (Slave) Converter .....</b>	<b>27</b>
<b>8.6</b>	<b>USB to SPI (Master) Converter .....</b>	<b>28</b>
<b>9</b>	<b>Package Parameters.....</b>	<b>29</b>
<b>9.1</b>	<b>FT311D Package Markings .....</b>	<b>29</b>
9.1.1	QFN-32 .....	29
9.1.2	LQFP-32 .....	30
<b>9.2</b>	<b>FT311D Package Dimensions .....</b>	<b>31</b>
9.2.1	QFN-32 Package Dimensions.....	31
9.2.2	LQFP-32 Package Dimensions.....	32
<b>9.3</b>	<b>Solder Reflow Profile .....</b>	<b>33</b>
<b>10</b>	<b>Contact Information .....</b>	<b>35</b>
	<b>Appendix A – References .....</b>	<b>36</b>
	<b>Useful utilities and examples firmware.....</b>	<b>36</b>
	<b>Appendix B - List of Figures and Tables .....</b>	<b>37</b>
	<b>Appendix C - Revision History.....</b>	<b>39</b>

### 3 Device Pin Out and Signal Description

#### 3.1 Package Symbol

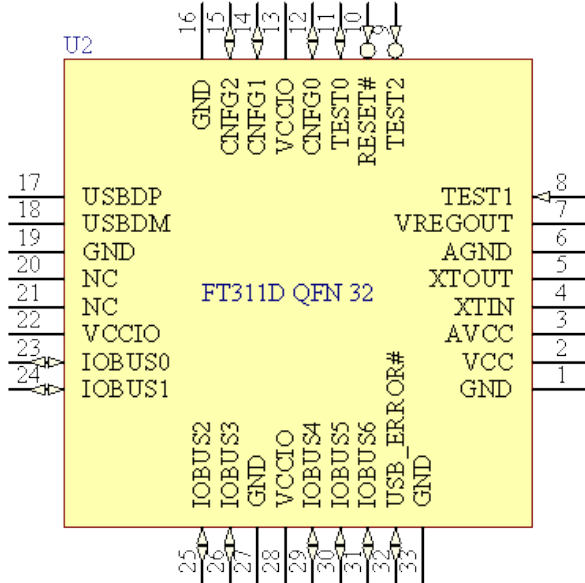

**Figure 3.1 QFN Schematic Symbol**

Note the pinout is the same for the QFN and LQFP packages.

#### 3.1.1 Package PinOut Description

Note: # denotes an active low signal.

Pin No.	Name	Type	Description
2	3.3V VREGIN	POWER Input	3V3 supply to IC internal 1V8 regulator
3	1.8V VCC PLL IN	POWER Input	1V8 supply to IC core
13, 22, 28	VCCIO	POWER Input	3V3 supply for the IO cells
7	VREGOUT	POWER Output	1V8 output. May be used as input source for pin 3.
1,6,16,19,27	GND	POWER Input	0V Ground input.

**Table 3.1 Power and Ground**

Pin No.	Name	Type	Description
17	USBDP	INPUT/OUTPUT	USB Data Signal Plus.
18	USBDM	INPUT/OUTPUT	USB Data Signal Minus.
4	XTIN	INPUT	Input to 12MHz Oscillator Cell. Connect 12MHz crystal across pins 4 and 5.
5	XTOUT	OUTPUT	Output from 12MHz Oscillator Cell. Connect 12MHz crystal across pins 4 and 5.
8	TEST1	INPUT	For internal use. Pull to GND
9	TEST2	INPUT	For factory use. Pull to 3V3.
10	RESET#	INPUT	Reset input (active low).
20, 21	NC	-	No connect pins. Leave unterminated.
11	TEST0	OUTPUT	Active low signal that may be used to control a switch for enabling power to the USB port pin 1 (VBUS).
12	CNFG0	INPUT	Configuration pin 0 used to select between GPIO,UART,PWM,I <sup>2</sup> C and SPI. Pull to Ground = Logic '0'(No external resistor needed) Leave Open = Logic '1' (Internal Pull up is present)
14	CNFG1	INPUT	Configuration pin 1 used to select between GPIO,UART,PWM,I <sup>2</sup> C and SPI. Pull to Ground = Logic '0'(No external resistor needed) Leave Open = Logic '1' (Internal Pull up is present)
15	CNFG2	INPUT	Configuration pin 2 used to select between GPIO,UART,PWM,I <sup>2</sup> C and SPI. Pull to Ground = Logic '0'(No external resistor needed) Leave Open = Logic '1' (Internal Pull up is present)
32	USB_ERROR#	OUTPUT	Output signal to indicate a problem with the USB connection

**Table 3.2 Common Function pins**

Pin No.	Name	Type	Description
23	IOBUS0	INPUT/OUTPUT	I/O signal. Function depends on CNFG pin setting. See table 3.4
24	IOBUS1	INPUT/OUTPUT	I/O signal. Function depends on CNFG pin setting. See table 3.4
25	IOBUS2	INPUT/OUTPUT	I/O signal. Function depends on CNFG pin setting. See table 3.4
26	IOBUS3	INPUT/OUTPUT	I/O signal. Function depends on CNFG pin setting. See table 3.4

29	IOBUS4	INPUT/OUTPUT	I/O signal. Function depends on CNFG pin setting. See table 3.4
30	IOBUS5	INPUT/OUTPUT	I/O signal. Function depends on CNFG pin setting. See table 3.4
31	IOBUS6	INPUT/OUTPUT	I/O signal. Function depends on CNFG pin setting. See table 3.4

**Table 3.3 Interface Pins**

Notes:

1. When used in Input Mode, the input pins are pulled to VCCIO via internal 75kΩ (approx.) resistors.

## 3.2 Interface Selection

The FT311D has multiple interfaces available for connecting to external devices. The resources available are GPIO, UART, PWM, I2C(Master), SPI(Slave) and SPI(Master). The selection of what interface the user requires is configured using the CNFG0, CNFG1 and CNFG2 input pins as per table 3.4.

CNFG2	CNFG1	CNFG0	Mode
GND	GND	GND	GPIO
GND	GND	Leave Open	UART
GND	Leave Open	GND	PWM
GND	Leave Open	Leave Open	I2C (Master)
Leave Open	GND	GND	SPI (Slave)
Leave Open	GND	Leave Open	SPI (Master)

**Table 3.4 CBUS Configuration Control**

Note 1: When left open the pin is a logic 1.

Note 2: Mode "110" is a factory test mode and should not be used.

Note 3: Mode "111" will default to GPIO mode.

### 3.2.1 Interface pinout

The actual pinout for each interface type is detailed in table 3.5

Pin No	Pin Name	GPIO	UART	PWM	I2C (Master)	SPI (Slave)	SPI (Master)
23	IOBUS0	GPIO0	UART_TXD	PWM0	I2C_CLK	-	-
24	IOBUS1	GPIO1	UART_RXD	PWM1	I2C_DATA	-	-
25	IOBUS2	GPIO2	UART_RTS #	PWM2	-	-	-
26	IOBUS3	GPIO3	UART_CTS #	PWM3	-	SPI_S_SS0	SPI_M_SS0



Pin No	Pin Name	GPIO	UART	PWM	I2C (Master)	SPI (Slave)	SPI (Master)
29	IOBUS4	GPIO4	UART_TX_ACTIVE	-	-	SPI_S_CLK	SPI_M_CLK
30	IOBUS5	GPIO5	-	-	-	SPI_S_MOSI	SPI_M_MOSI
31	IOBUS6	GPIO6	-	-	-	SPI_S_MISO	SPI_M_MISO

**Table 3.5 I/O Configuration**

## 4 Function Description

FT311D is FTDI's Android Accessory Mode integrated circuit device or Android Host. The FT311D behaves like a bridge between an Android device and the various I/O available. Selection of various modes is performed using CNFGx pins.

### 4.1 Key Features

Easy to use Android accessory IC translating the Device port of the android tablet into either GPIO, UART, PWM, I<sup>2</sup>C Master, SPI Slave or SPI Master capabilities

### 4.2 Functional Block Descriptions

The following paragraphs describe each function within FT311D. Please refer to the block diagram shown in **Figure 2.1**.

#### 4.2.1 Peripheral Interface Modules

FT311D has six peripheral interface modules available for selection. Full descriptions of each module are described in [Section 5](#).

- GPIO - General purpose I/O pins
- UART
- PWM
- I2C Master
- SPI Slave
- SPI Master

#### 4.2.2 USB Transceivers

USB transceiver cells provide the physical USB device interface supporting USB 1.1 and USB 2.0 standards. Low-speed and full-speed USB data rates are supported. The output driver provides +3.3V level slew rate control signalling, whilst a differential receiver and two single ended receivers provide USB DATA IN, SE0 and USB Reset condition detection. These cells also include integrated internal pull-down resistors as required for host mode.

#### 4.2.3 USB Host

These blocks handle the parallel-to-serial and serial-to-parallel conversion of the USB physical layer. This includes bit stuffing, CRC generation.

### 4.3 I/O Peripherals Signal Names

Peripheral	Signal Name	Outputs	Inputs	Description
GPIO	gpio	7	7	General purpose I/O
UART	uart_txd	1	0	Transmit asynchronous data output
	uart_rts#	1	0	Request to send control output
	uart_rxd	0	1	Receive asynchronous data input
	uart_cts#	0	1	Clear to send control input
	uart_tx_active	0	1	UART active signal (typically used with RS485)
PWM	pwm	4	0	Pulse width modulation
I <sup>2</sup> C	I2c_scl	0	1	I2C bus serial clock line - slave
	I2c_sda	1	1	I2C bus serial data line - slave
SPI Slave	spi_s_clk	0	1	SPI clock input

	spi_s_ss#	0	1	SPI slave select input
	spi_s_mosi	1	1	SPI master out serial in
	spi_s_miso	1	0	SPI master in slave out
SPI Master	spi_m_clk	1	0	SPI clock input - master
	spi_m_mosi	1	1	Master out slave in - master
	spi_m_miso	0	1	Master in slave out - master
	spi_m_ss_0#	1	0	Active low slave select 0 from master to slave 0

**Table 4.1 I/O Peripherals Signal Names**

Note: # is used to indicate an active low signal.

## 4.4 Default Mode Strings

When the USB port is connected to the Android USB port, the Android platform will determine which application to load based on the strings read from the FT311D. These strings are configurable with a Windows utility: FT311Cofiguration.exe available for download from the FTDI website at:

<http://www.ftdichip.com/Android/FT311Configuration.zip>

Default values for the strings are set in the device as per Table 4.2

Descriptor String	Default Value
Manufacturer	FTDI
Model (depends on GPIO Mode selection):	
GPIO	FTDIGPIODemo
UART	FTDIUARTDemo
PWM	FTDIPWMDemo
I <sup>2</sup> C	FTDII2CDemo
SPI Slave	FTDISPISlaveDemo
SPI Master	FTDISPIMasterDemo
Version	1.0
Serial	VinculumAccessory1
Description URL	<a href="http://www.ftdichip.com">http://www.ftdichip.com</a>

**Table 4.2 Default Descriptor Strings**

## 5 Peripheral Interfaces

In addition to the USB Host, FT311D contains the following peripheral interfaces:

- General Purpose Input Output (GPIO)
- Universal Asynchronous Receiver Transmitter (UART)
- Four Pulse Width Modulation blocks (PWM)
- I<sup>2</sup>C Master
- Serial Peripheral Interface (SPI) Slave
- Serial Peripheral Interface (SPI) Master

Note: Only one interface may be selected at any time.

The modes are selected by setting the CNFGx pins.

The following sections describe each peripheral in detail.

### 5.1 General Purpose Input Output

FT311D provides up to 7 configurable Input/Output pins. All pins are independently configurable to be either inputs or outputs.

### 5.2 UART Interface

When the peripheral interface is configured in UART mode, the interface implements a standard asynchronous serial UART port with flow control, for example RS232/422/485. The UART can support baud rates from 300 baud to 6 Mbaud.

Data transfer uses NRZ (Non-Return to Zero) data format consisting of 1 start bit, 7 or 8 data bits, an optional parity bit, and one or two stop bits. When transmitting the data bits, the least significant bit is transmitted first. Transmit and receive waveforms are illustrated in **Figure 5-1** and **Figure 5-2**:

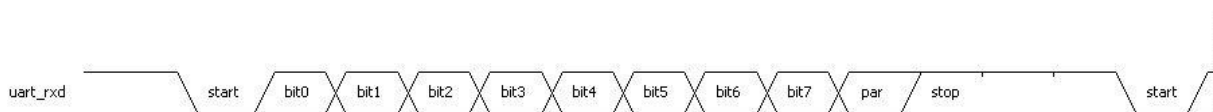

**Figure 5-1 UART Receive Waveform**

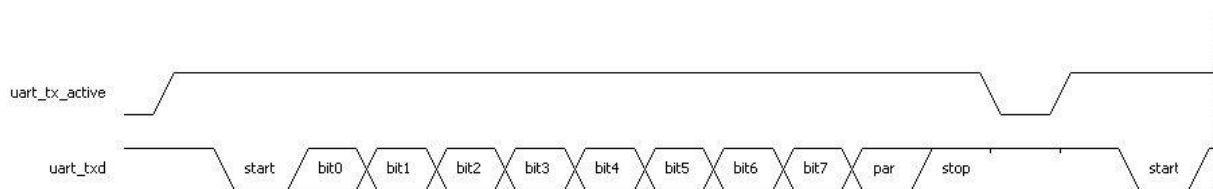

**Figure 5-2 UART Transmit Waveform**

Baud rate (default =9600 baud), flow control settings (default = RTS/CTS), number of data bits (default=8), parity (default is no parity) and number of stop bits (default=1) are all configurable from the Android application. Please refer to [http://www.ftdichip.com/Support/Documents/ProgramGuides.htm/FT311\\_Android\\_Programmers\\_Guide.pdf](http://www.ftdichip.com/Support/Documents/ProgramGuides.htm/FT311_Android_Programmers_Guide.pdf) for further details.

uart\_tx\_active is transmit enable, this output may be used in RS485 designs to control the transmit of the line driver.

## 5.2.1 UART Mode Signal Descriptions

The UART signals are fixed on the I/O pins. Table 5.1 UART Interface, details the pins for each of the UART signals.

Pin No	Name	Type	Description
23	uart_txd	Output	Transmit asynchronous data output
24	uart_rxd	Input	Receive asynchronous data input
25	uart_rts#	Output	Request to send control output
26	uart_cts#	Input	Clear to send control input
29	uart_tx_active	output	Transmit enable (typically used for RS485 designs)

**Table 5.1 UART Interface**

## 5.3 Pulse Width Modulation

FT311D provides 4 Pulse Width Modulation (PWM) outputs. These can be used to generate PWM signals which can be used to control motors, DC/DC converters, AC/DC supplies, etc. Further information is available in an Application Note AN\_140 - [Vinculum-II PWM Example](#).

The features of the PWM module are as follows:

- 4 PWM outputs
- Variable frequency
- Variable duty cycle

## 5.4 I2C

I<sup>2</sup>C (Inter Integrated Circuit) is a multi-master serial bus invented by Philips. I<sup>2</sup>C uses two bi-directional open-drain wires called serial data (SDA) and serial clock (SCL). Common I<sup>2</sup>C bus speeds are the 100 kbit/s standard mode (SM), 400 kbit/s fast mode (FM), 1 Mbit/s Fast mode plus (FM+), and 3.4 Mbit/s High Speed mode (HS)

An I<sup>2</sup>C bus node can operate either as a master or a slave:

- Master node - issues the clock and addresses slaves
- Slave node - receives the clock line and address.

FT311D provides an I2C master interface for connection to other I2C Slave interfaces up to 125kbit/s.

The master is initially in master transmit mode by sending a start bit followed by the 7-bit address of the slave it wishes to communicate with, which is finally followed by a single bit representing whether to write(0) to, or read(1) from the slave.

If the slave exists on the bus then it will respond with an ACK bit (active low for acknowledged) for that address. The master then continues in either transmit or receive mode (according to the read/write bit it sent), and the slave continues in its complementary mode (receive or transmit, respectively).

The address and the data bytes are sent most significant bit first. The start bit is indicated by a high-to-low transition of SDA with SCL high; the stop bit is indicated by a low-to-high transition of SDA with SCL high.

If the master has to write to the slave then it repeatedly sends a byte with the slave sending an ACK bit. (In this situation, the master is in master transmit mode and the slave is in slave receive mode.)

If the master has to read from the slave then it repeatedly receives a byte from the slave, the master sending an ACK bit after every byte but the last one. (In this situation, the master is in master receive mode and the slave is in slave transmit mode.)

The master then ends transmission with a stop bit, or it may send another START bit if it wishes to retain control of the bus for another transfer (a "combined message").

I<sup>2</sup>C defines three basic types of message, each of which begins with a START and ends with a STOP:

- Single message where a master writes data to a slave;
- Single message where a master reads data from a slave;
- Combined messages, where a master issues at least two reads and/or writes to one or more slaves

In a combined message, each read or write begins with a START and the slave address. After the first START, these are also called repeated START bits; repeated START bits are not preceded by STOP bits, which is how slaves know the next transfer is part of the same message.

Please refer to the I<sup>2</sup>C specification for more information on the protocol.

## 5.5 Serial Peripheral Interface – SPI Modes

The Serial Peripheral Interface Bus is an industry standard communications interface. Devices communicate in Master / Slave mode, with the Master initiating the data transfer.

FT311D has one master module and one slave module. Both the SPI master and slave module has four signals – clock, slave select, MOSI (master out – slave in) and MISO (master in – slave out). Table 5.2 lists how the signals are named in each module.

Module	Signal Name	Type	Description
SPI Slave	spi_s_clk	Input	Clock input
	spi_s_ss#	Input	Active low slave select input
	spi_s_mosi	Input	Master out serial in
	spi_s_miso	Output	Master in slave out
SPI Master	spi_m_clk	Output	Clock output – master
	spi_m_mosi	Output	Master out slave in - master
	spi_m_miso	Input	Master in slave out - master
	spi_m_ss_0#	Output	Active low slave select 0 from master to slave 0

**Table 5.2 SPI Signal Names**

The SPI slave protocol by default does not support any form of handshaking. It is simply transferring 8 bit data.

### 5.5.1 SPI Clock Phase Modes

SPI interface has 4 unique modes of clock phase (CPHA) and clock polarity (CPOL), known as Mode 0, Mode 1, Mode 2 and Mode 3. Table 5.3 summarizes these modes and available interface and **Figure 5-3** is the function timing diagram.

For CPOL = 0, the base (inactive) level of SCLK is 0.

In this mode:

- When CPHA = 0, data is clocked in on the rising edge of SCLK, and data is clocked out on the falling edge of SCLK.
- When CPHA = 1, data is clocked in on the falling edge of SCLK, and data is clocked out on the rising edge of SCLK

For CPOL =1, the base (inactive) level of SCLK is 1.

In this mode:

- When CPHA = 0, data is clocked in on the falling edge of SCLK, and data is clocked out on the rising edge of SCLK
- When CPHA =1, data is clocked in on the rising edge of SCLK, and data is clocked out on the falling edge of SCLK.

Mode	CPOL	CPHA
0	0	0
1	0	1
2	1	0
3	1	1

**Table 5.3 - Clock Phase/Polarity Modes**

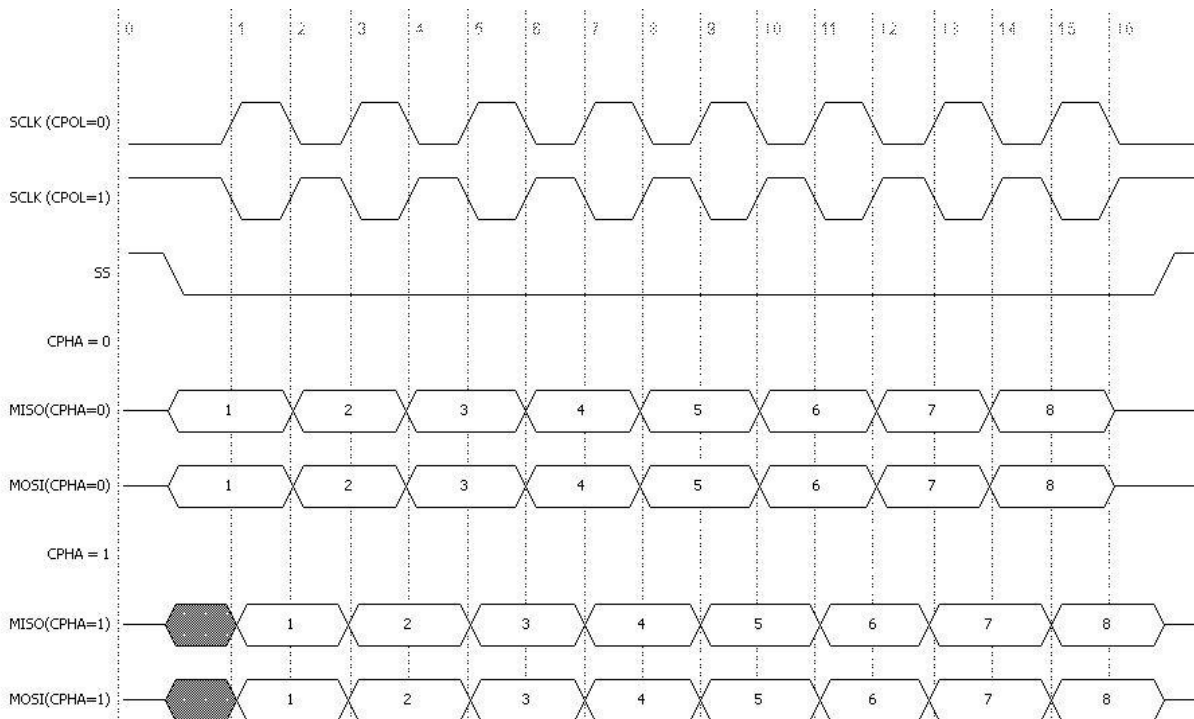

**Figure 5-3 - SPI CPOL CPHA Function**

### 5.5.2 Serial Peripheral Interface – Slave

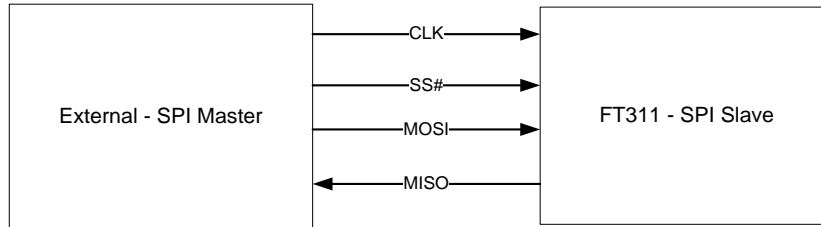

**Figure 5-4 SPI Slave block diagram**

FT311D has an SPI Slave module that uses four wire interfaces: MOSI, MISO, CLK and SS#. An SPI transfer can only be initiated by the SPI Master and begins with the slave select signal being asserted. This is followed by a data byte being clocked out with the master supplying CLK. The master always supplies the first byte, which is called a command byte. After this the desired number of data bytes are transferred before the transaction is terminated by the master de-asserting slave select. An SPI Master is able to abort a transfer at any time by de-asserting its SS# output. This will cause the Slave to end its current transfer and return to idle state.

#### 5.5.2.1 SPI Slave Signal Descriptions

Pin No	Name	Type	Description
29	spi_s0_clk	Input	Slave clock input
30	spi_s0_mosi	Input	Master Out Slave In Synchronous data from master to slave
31	spi_s0_miso	Output	Master In Slave Out Synchronous data from slave to master
26	spi_s0_ss#	Input	Slave select

**Table 5.4 Data and Control Bus Signal Mode Options - SPI Slave Interface**

### 5.5.3 Serial Peripheral Interface – SPI Master

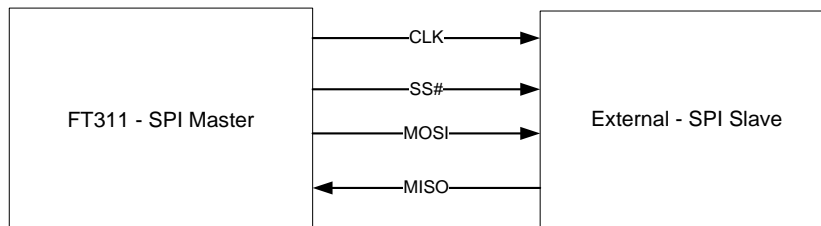

**Figure 5-5 SPI Master block diagram**

The SPI Master interface is used to interface to applications such as Real time clocks and audio codecs. The SPI Master provides the following features:



- Synchronous serial data link.
- Full and half duplex data transmission.
- Serial clock with programmable frequency, polarity and phase.
- One slave select output.

### 5.5.3.1 SPI Master Signal Descriptions.

Table 5.5 shows the SPI master signals and the pins

Pin No	Name	Type	Description
29	spi_m_clk	Output	SPI master clock input
30	spi_m_mosi	Output	Master Out Slave In Synchronous data from master to slave
31	spi_m_miso	Input	Master In Slave Out Synchronous data from slave to master
26	spi_m_ss_0#	Output	Active low slave select 0 from master to slave

**Table 5.5 SPI Master Signal Names**

The main purpose of the SPI Master block is to transfer data between an external SPI interface and the FT311D.

An SPI master interface transfer can only be initiated by the SPI Master and begins with the slave select signal being asserted. This is followed by a data byte being clocked out with the master supplying SCLK. The master typically supplies the first byte, which is called a command byte. After this the desired number of data bytes are transferred before the transaction is terminated by the master de-asserting slave select. However the FT311D is simply a data pipe and no command is required by the FT311D itself. Any command protocol would be defined by the Android application.

The SPI Master will transmit on MOSI as well as receive on MISO during every data stage.

Figure 5-6 Typical SPI Master Timing and Table 5.6 SPI Master Timing show an example of this.

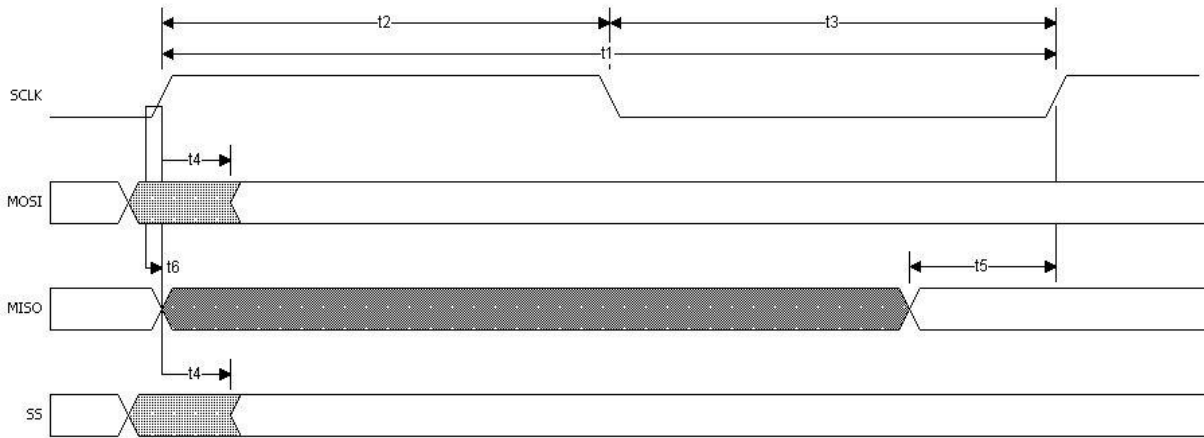

**Figure 5-6 Typical SPI Master Timing**

Time	Description	Minimum	Typical	Maximum	Unit
t1	SCLK period	39.68	41.67		ns
t2	SCLK high period	19.84	20.84	21.93	ns
t3	SCLK low period	19.84	20.84	21.93	ns
t4	SCLK driving edge to MOSI/SS	-1.5		3	ns
t5	MISO setup time to sample SCLK edge			6.5	ns
t6	MISO hold time from sample SCLK edge	0			ns

**Table 5.6 SPI Master Timing**

## 6 USB Error Detection

Pin 32 (IOBUS7) of the device is provided to indicate a problem has occurred with the USB connection. Typical errors include USB Device Not Supported, which would occur if the USB port was connected to a non-Android class device port e.g. the FT311D is not designed to host memory sticks or printers etc. USB Device Not Responding and Hub not supported would be reported also if connected to a hub. The signal states are as follows:

Pin state	Definition
Logic 0	Device connected to USB and functional
Logic 1	Device not connected
One 50ms logic 0 pulse	Device not responding. This pulse occurs at plug-in and then the signal returns to logic 1. This then repeats at a 1 second interval.
Two 50ms logic 0 pulses	Device not supported. These pulses occur at plug-in and then the signal returns to logic 1. This then repeats at a 1 second interval.
Three 50ms logic 0 pulses	Hub not supported. These pulses occur at plug-in and then the signal returns to logic 1. This then repeats at a 1 second interval.

**Table 6.1 Error Detection**

## 7 Absolute Maximum Ratings

The absolute maximum ratings for FT311D are shown in Table 7.1. These are in accordance with the Absolute Maximum Rating System (IEC 60134). Exceeding these may cause permanent damage to the device.

Parameter	Value	Unit
Storage Temperature	-65°C to 150°C	Degrees C
Floor Life (Out of Bag) At Factory Ambient ( 30°C / 60% Relative Humidity)	168 Hours (IPC/JEDEC J-STD-033A MSL Level 3 Compliant)*	Hours
Ambient Temperature (Power Applied)	-40°C to 85°C	Degrees C.
Vcc Supply Voltage	0 to +3.63	V
VCC_IO	0 to +3.63	V
VCC_PLL_IN	0 to + 1.98	V
DC Input Voltage - USBDP and USBDM	-0.5 to +(Vcc +0.5)	V
DC Input Voltage - High Impedance Bidirectional	-0.5 to +5.00	V
DC Input Voltage - All other Inputs	-0.5 to +(Vcc +0.5)	V
DC Output Current - Outputs	4	mA
DC Output Current - Low Impedance Bidirectional	4	mA

**Table 7.1 Absolute Maximum Ratings**

- \* If devices are stored out of the packaging beyond this time limit the devices should be baked before use. The devices should be ramped up to a temperature of 125°C and baked for up to 17 hours.

### 7.1 DC Characteristics

DC Characteristics (Ambient Temperature -40°C to +125°C)

Parameter	Description	Minimum	Typical	Maximum	Units	Conditions
Vcc1	VCC Operating Supply Voltage	2.97	3.3	3.63	V	

Vcc2	VCCIO Operating Supply Voltage	2.97	3.3	3.63	V	
VCC_PLL	VCC_PLL Operating Supply Voltage	1.62	1.8	1.98	V	
Icc1	Operating Supply Current 48MHz		25		mA	Normal Operation
Icc2	Operating Supply Current		128		μA	USB Suspend

**Table 7.2 Operating Voltage and Current**

Parameter	Description	Minimum	Typical	Maximum	Units	Conditions
Voh	Output Voltage High	2.4			V	I source = 8mA
Vol	Output Voltage Low			0.4	V	I sink = 8mA
Vin	Input Switching Threshold		1.5		V	

**Table 7.3 I/O Pin Characteristics**

Parameter	Description	Minimum	Typical	Maximum	Units	Conditions
UVoh	I/O Pins Static Output ( High )	2.8			V	
UVol	I/O Pins Static Output ( Low )			0.3	V	
UVse	Single Ended Rx Threshold	0.8		2.0	V	
UCom	Differential Common Mode	0.8		2.5	V	
UVdif	Differential Input Sensitivity	0.2			V	
UDrvZ	Driver Output Impedance	3	6	9	Ohms	

**Table 7.4 USB I/O Pin (USB DP, USB DM) Characteristics**

Parameter	Description	Minimum	Typical	Maximum	Units	Conditions
V <sub>CK</sub>	Power supply of internal core cells and I/O to core interface	1.62	1.8	1.98	V	1.8V power supply
V <sub>CC18IO</sub>	Power supply of 1.8V OSC pad	1.62	1.8	1.98	V	1.8V power supply
T <sub>J</sub>	Operating junction temperature	-40	25	125	°C	
I <sub>in</sub>	Input leakage current	-10	±1	10	μA	I <sub>in</sub> = V <sub>CC18IO</sub> or 0V
I <sub>oz</sub>	Tri-state output leakage current	-10	±1	10	μA	

**Table 7.5 Crystal Oscillator 1.8 Volts DC Characteristics**

## 7.2 ESD and Latch-up Specifications

Description	Specification
Human Body Mode (HBM)	± 2000V
Machine mode (MM)	± 200V
Charged Device Mode (CDM)	± 500V
Latch-up	> ± 200mA

**Table 7.6 ESD and Latch-up Specifications**

## 8 Application Examples

The following sections illustrate possible applications of the FT311D.

### 8.1 USB to GPIO Converter

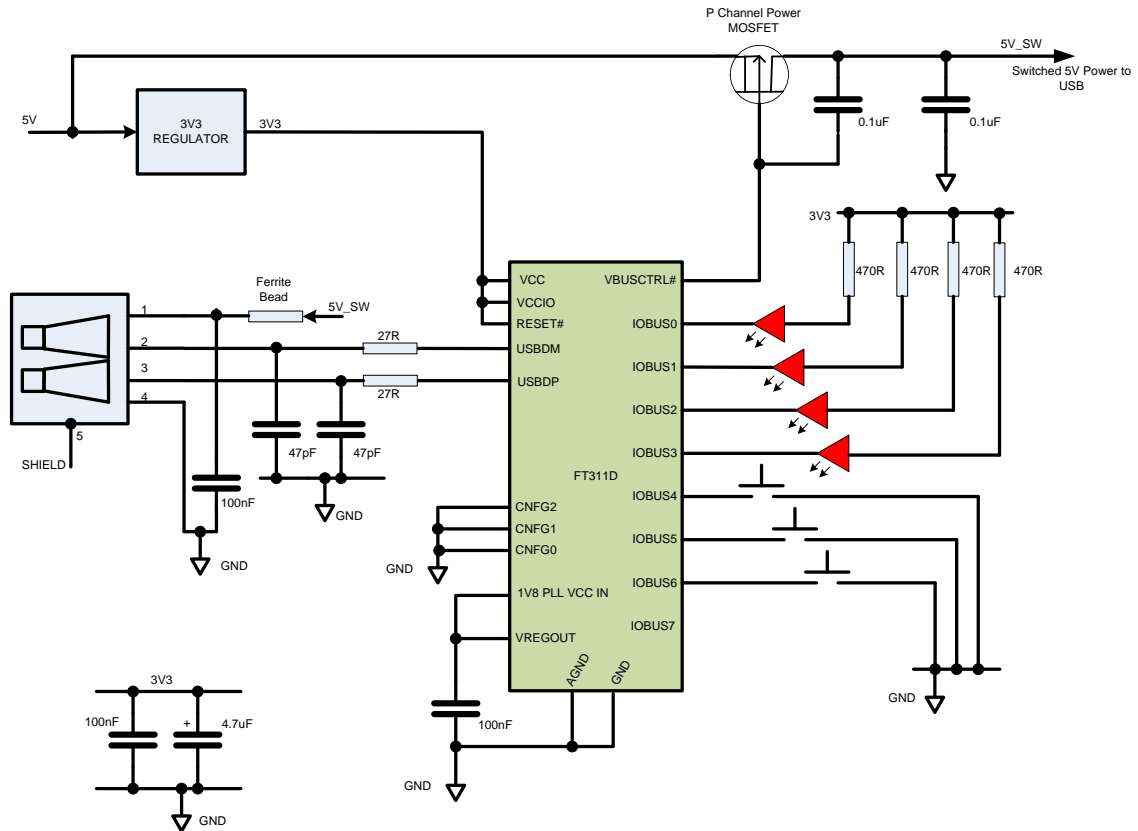

**Figure 8.1 Application Example showing USB to GPIO Converter**

This example shows the CNFGx pins set for mode 000 – GPIO.

IOBUS0-3 are configured as outputs by the Android application to control the LEDs.

IOBUS4-6 pins are configured as inputs to allow the buttons to control actions in the Android application.

Power to the USB port is enabled by the VBUSCTRL# signal

## 8.2 USB to UART Converter

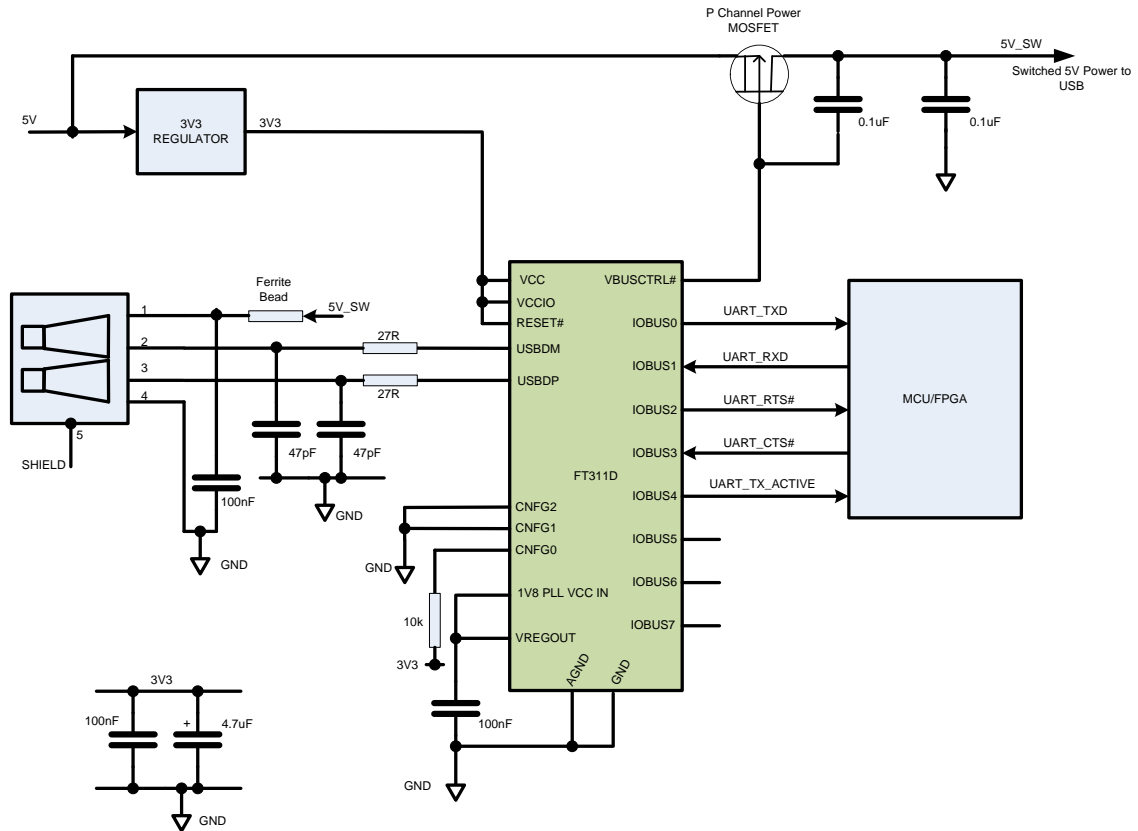

**Figure 8.2 Application Example showing USB to UART Converter**

This example shows the CNFGx pins set for mode 001 - UART.

The UART signals are at 3V3 level and may be used to drive directly into a FPGA or MCU with a 3V3 interface, or could be level shifted with an RS232, RS422 or RS485 transceiver. The UART\_TX\_ACTIVE signal is used mostly with RS485 transceivers to enable the transmit drivers.

The unused pins may be left unterminated.

Power to the USB port is enabled by the VBUSCTRL# signal







## 8.5 USB to SPI (Slave) Converter

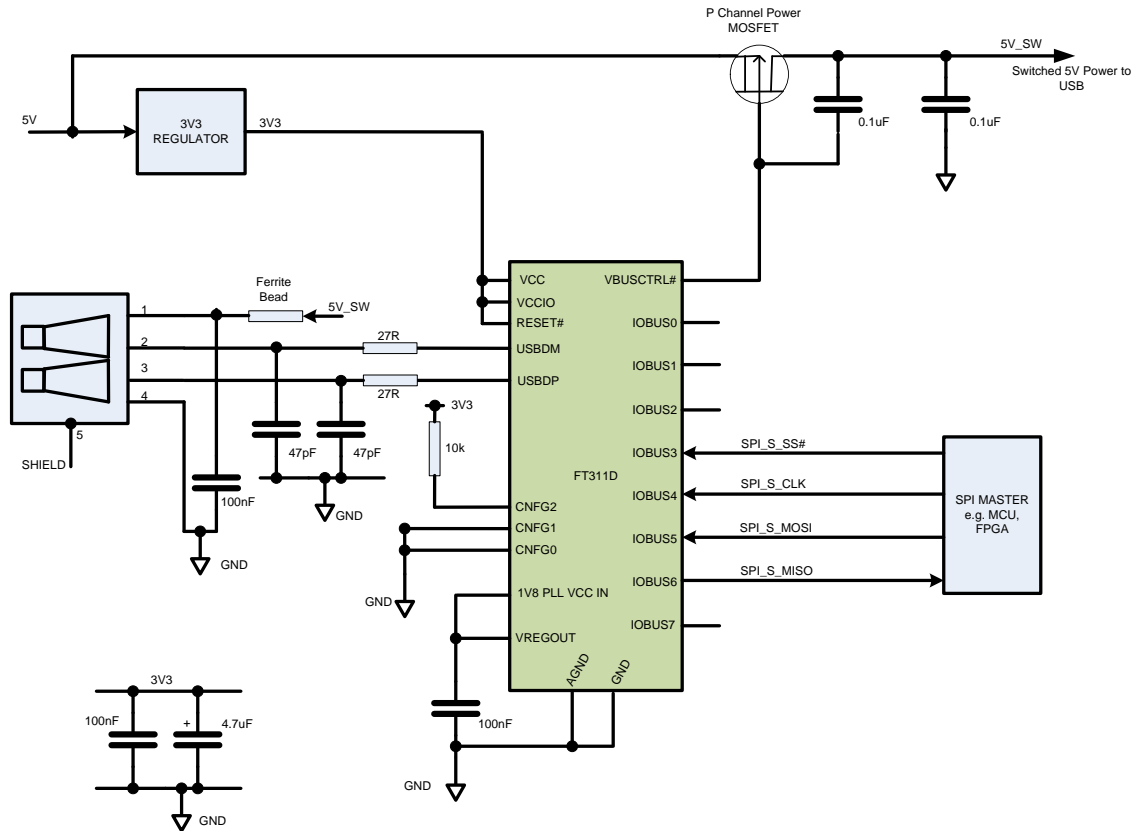

**Figure 8.5 Application Example showing USB to SPI (Slave) Converter**

This example shows the CNFGx pins set for mode 100 – SPI (Slave).

The external SPI Master controls the slave select line and the clock to the FT311D.

SPI\_S\_MOSI is the FT311D data input line which may be Most or Least Significant Bit first.

SPI\_S\_MISO is the FT311D data output line which may be Most or Least Significant Bit first.

Example SPI masters include MCU's and FPGA's

The unused pins may be left unterminated.

Power to the USB port is enabled by the VBUSCTRL# signal

## 8.6 USB to SPI (Master) Converter

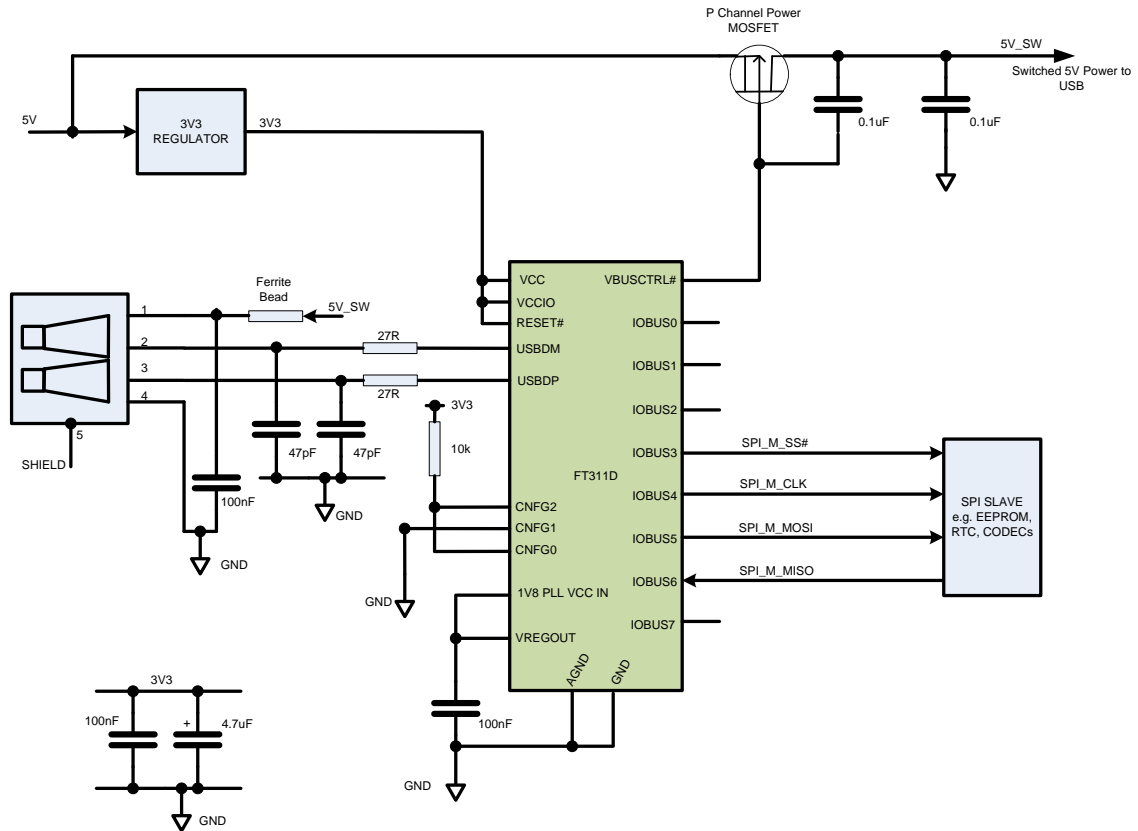

**Figure 8.6 Application Example showing USB to SPI (Master) Converter**

This example shows the CNFGx pins set for mode 101 – SPI (Master).

The FT311D SPI Master controls the slave select line and the clock to the external SPI slave.

SPI\_M\_MOSI is the FT311D data output line which may be Most or Least Significant Bit first.

SPI\_M\_MISO is the FT311D data input line which may be Most or Least Significant Bit first.

Example SPI Slave devices include memory, RTC, and codec devices.

The unused pins may be left unterminated.

Power to the USB port is enabled by the VBUSCTRL# signal

## 9 Package Parameters

FT311D is available in RoHS Compliant packages, QFN package (32QFN) and an LQFP package (32LQFP). The packages are lead (Pb) free and use a 'green' compound. The package is fully compliant with European Union directive 2002/95/EC.

The mechanical drawings of the packages are shown in **sections 9.2**- all dimensions are in millimetres.

The solder reflow profile for all packages can be viewed in **Section 9.3**.

### 9.1 FT311D Package Markings

#### 9.1.1 QFN-32

An example of the markings on the QFN package are shown in Figure 9-1. The FTDI part number is too long for the 32 QFN package so in this case the last two digits are wrapped down onto the date code line.

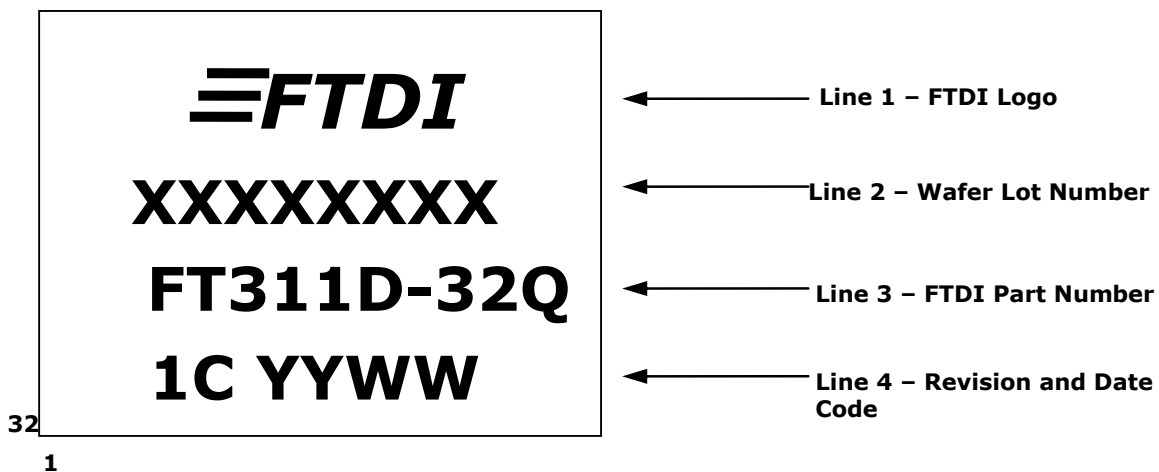

**Figure 9-1 QFN Package Markings**

1C should be printed on line 4, then a space and then the Date Code.

1. YYWW = Date Code, where YY is year and WW is week number
2. Marking alignment should be centre justified
3. Laser Marking should be used
4. All marking dimensions should be marked proportionally. Marking font should be using Unisem standard font (Roman Simplex)

### 9.1.2 LQFP-32

An example of the markings on the LQFP package are shown in Figure 9-2.

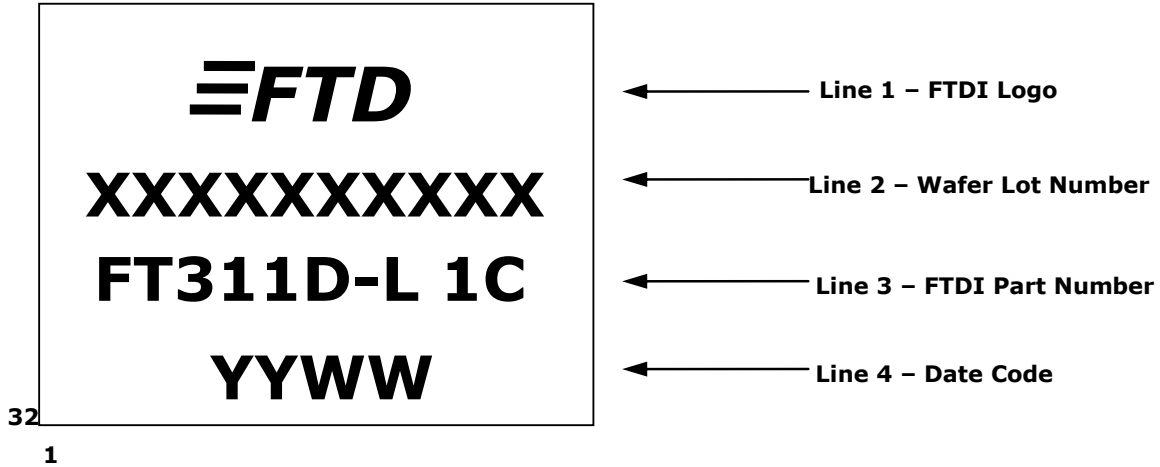

**Figure 9-2 LQFP Package Markings**

**Notes:**

1. YYWW = Date Code, where YY is year and WW is week number
2. Marking alignment should be centre justified
3. Laser Marking should be used
4. All marking dimensions should be marked proportionally. Marking font should be using Unisem standard font (Roman Simplex)

## 9.2 FT311D Package Dimensions

### 9.2.1 QFN-32 Package Dimensions

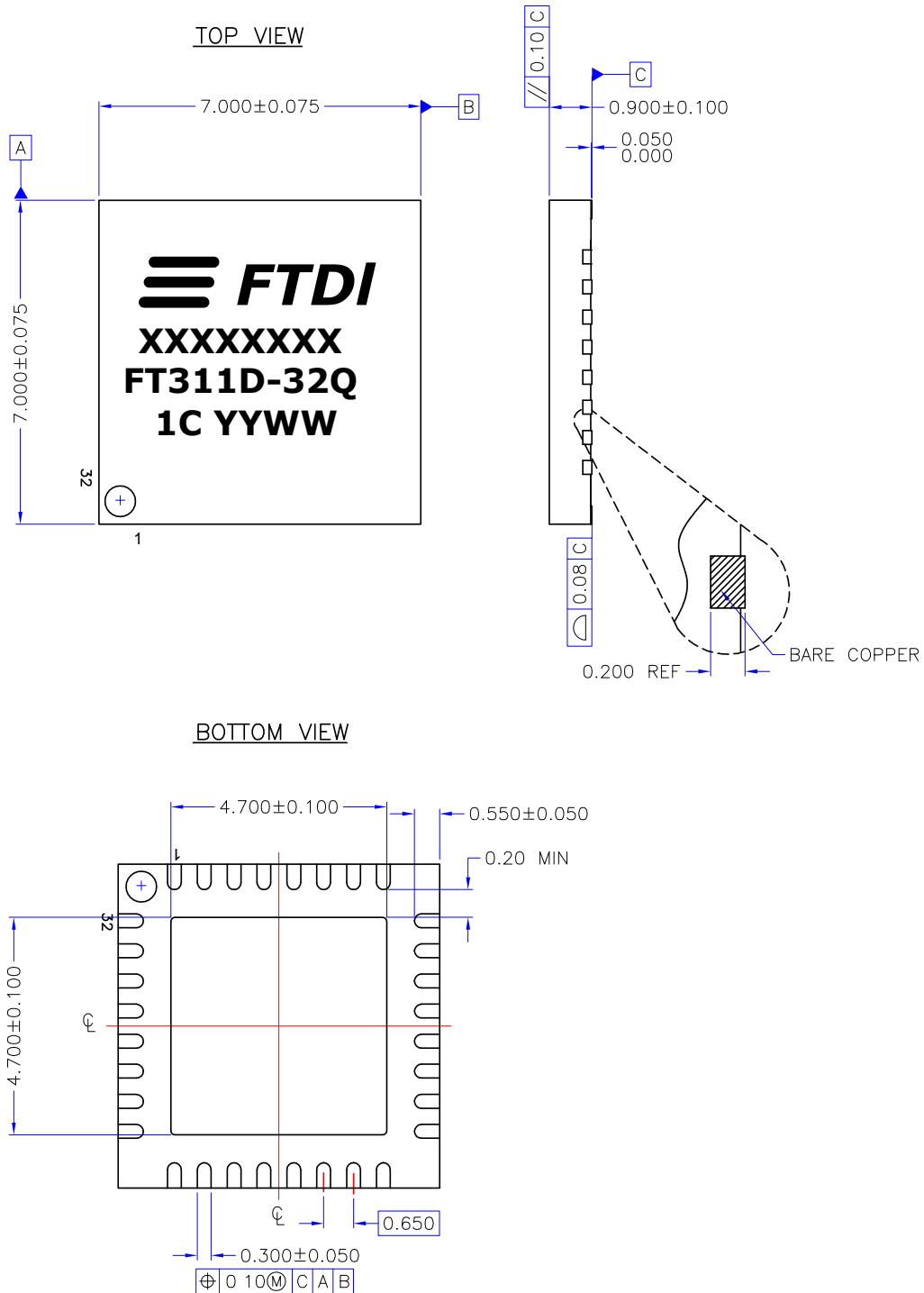

**Figure 9-3 QFN-32 Package Dimensions**

Note: Dimensions are in mm

Note: The centre pad should be connected to the GND plane for improved thermal conduction and noise immunity.

### 9.2.2 LQFP-32 Package Dimensions

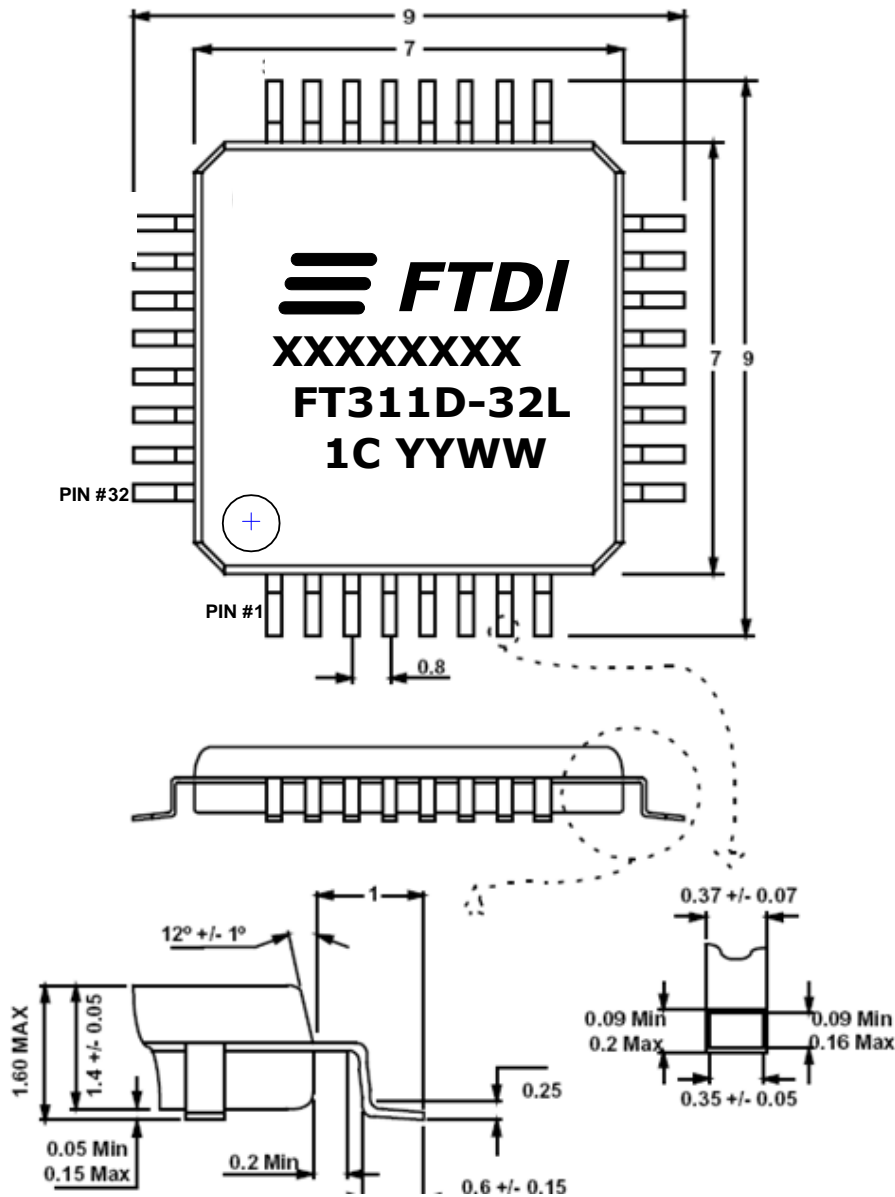

Figure 9-4 LQFP-32 Package Dimensions

Note: Dimensions are in mm



### 9.3 Solder Reflow Profile

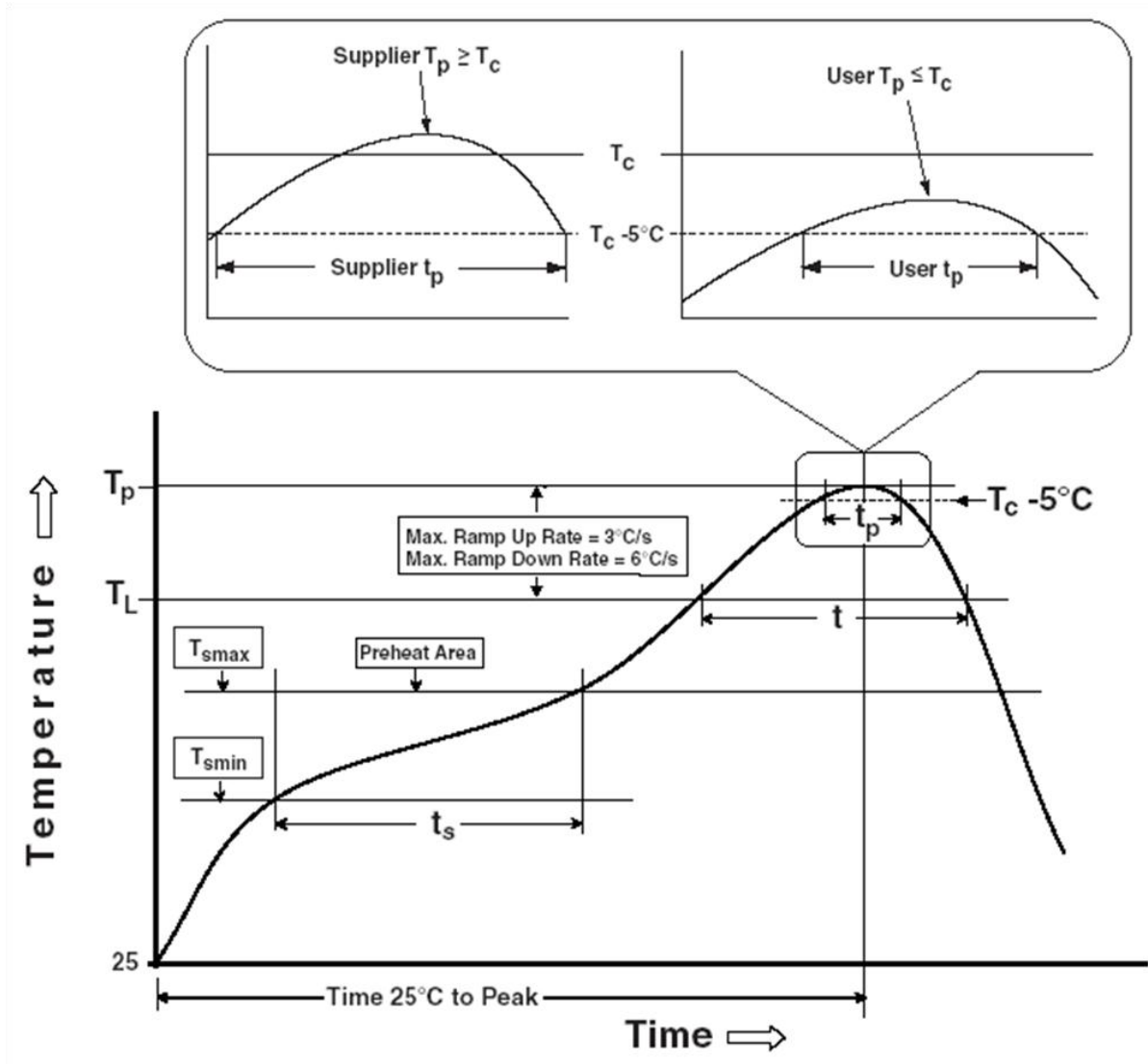

Figure 9-5 All packages Reflow Solder Profile

Profile Feature	Pb Free Solder Process (green material)	SnPb Eutectic and Pb free (non green material) Solder Process
Average Ramp Up Rate ( $T_s$ to $T_p$ )	3°C / second Max.	3°C / Second Max.
Preheat - Temperature Min ( $T_s$ Min.) - Temperature Max ( $T_s$ Max.) - Time ( $t_s$ Min to $t_s$ Max)	150°C 200°C 60 to 120 seconds	100°C 150°C 60 to 120 seconds
Time Maintained Above Critical Temperature $T_L$ : - Temperature ( $T_L$ ) - Time ( $t_L$ )	217°C 60 to 150 seconds	183°C 60 to 150 seconds
Peak Temperature ( $T_p$ )	260°C	see Figure 9-5
Time within 5°C of actual Peak Temperature ( $t_p$ )	30 to 40 seconds	20 to 40 seconds
Ramp Down Rate	6°C / second Max.	6°C / second Max.
Time for $T = 25^\circ\text{C}$ to Peak Temperature, $T_p$	8 minutes Max.	6 minutes Max.

**Table 9.1 Reflow Profile Parameter Values**

SnPb Eutectic and Pb free (non green material)		
Package Thickness	Volume mm <sup>3</sup> < 350	Volume mm <sup>3</sup> ≥350
< 2.5 mm	235 +5/-0 deg C	220 +5/-0 deg C
≥ 2.5 mm	220 +5/-0 deg C	220 +5/-0 deg C
Pb Free (green material) = 260 +5/-0 deg C		

**Table 9.2 Package Reflow Peak Temperature**

## 10 Contact Information

### Head Office – Glasgow, UK

Future Technology Devices International Limited  
Unit 1, 2 Seaward Place, Centurion Business Park  
Glasgow G41 1HH  
United Kingdom  
Tel: +44 (0) 141 429 2777  
Fax: +44 (0) 141 429 2758

E-mail (Sales) [sales1@ftdichip.com](mailto:sales1@ftdichip.com)  
E-mail (Support) [support1@ftdichip.com](mailto:support1@ftdichip.com)  
E-mail (General Enquiries) [admin1@ftdichip.com](mailto:admin1@ftdichip.com)

### Branch Office – Hillsboro, Oregon, USA

Future Technology Devices International Limited (USA)  
7235 NW Evergreen Parkway, Suite 600  
Hillsboro, OR 97123-5803  
USA  
Tel: +1 (503) 547 0988  
Fax: +1 (503) 547 0987

E-Mail (Sales) [us.sales@ftdichip.com](mailto:us.sales@ftdichip.com)  
E-Mail (Support) [us.support@ftdichip.com](mailto:us.support@ftdichip.com)  
E-Mail (General Enquiries) [us.admin@ftdichip.com](mailto:us.admin@ftdichip.com)

### Branch Office – Taipei, Taiwan

Future Technology Devices International Limited  
(Taiwan)  
2F, No. 516, Sec. 1, NeiHu Road  
Taipei 114  
Taiwan, R.O.C.  
Tel: +886 (0) 2 8791 3570  
Fax: +886 (0) 2 8791 3576

E-mail (Sales) [tw.sales1@ftdichip.com](mailto:tw.sales1@ftdichip.com)  
E-mail (Support) [tw.support1@ftdichip.com](mailto:tw.support1@ftdichip.com)  
E-mail (General Enquiries) [tw.admin1@ftdichip.com](mailto:tw.admin1@ftdichip.com)

### Branch Office – Shanghai, China

Room 1103, No. 666 West Huaihai Road,  
Shanghai, 200052  
China  
Tel: +86 21 62351596  
Fax: +86 21 62351595

E-mail (Sales) [cn.sales@ftdichip.com](mailto:cn.sales@ftdichip.com)  
[cn.support@ftdichip.com](mailto:cn.support@ftdichip.com)  
E-mail (Support) [cn.admin@ftdichip.com](mailto:cn.admin@ftdichip.com)  
E-mail (General Enquiries)

---

## **Appendix A – References**

### **Useful Application Notes**

[http://www.ftdichip.com/Documents/White\\_Papers/WP\\_001\\_Connecting\\_Peripherals\\_to\\_an\\_Android\\_Platform.pdf](http://www.ftdichip.com/Documents/White_Papers/WP_001_Connecting_Peripherals_to_an_Android_Platform.pdf)

[http://www.ftdichip.com/Support/Documents/ProgramGuides.htm/FT311\\_Android\\_Programmers\\_Guide.pdf](http://www.ftdichip.com/Support/Documents/ProgramGuides.htm/FT311_Android_Programmers_Guide.pdf)

### **Useful utilities and examples firmware**

<http://www.ftdichip.com/Android/FT311Configuration.zip>

<http://www.ftdichip.com/Android/SampleApps.zip>

## Appendix B - List of Figures and Tables

### List of Figures

Figure 2.1 FT311D Block Diagram .....	3
Figure 3.1 QFN Schematic Symbol .....	6
Figure 5-1 UART Receive Waveform .....	12
Figure 5-2 UART Transmit Waveform .....	12
Figure 5-4 - SPI CPOL CPHA Function .....	15
Figure 5-5 SPI Slave block diagram.....	16
Figure 5-6 SPI Master block diagram .....	16
Figure 5-7 Typical SPI Master Timing .....	18
Figure 7.1 Application Example showing USB to GPIO Converter .....	23
Figure 8.2 Application Example showing USB to UART Converter .....	24
Figure 8.3 Application Example showing USB to PWM Converter .....	25
Figure 8.4 Application Example showing USB to I <sup>2</sup> C (Master) Converter .....	26
Figure 8.5 Application Example showing USB to SPI (Slave) Converter .....	27
Figure 8.6 Application Example showing USB to SPI (Master) Converter .....	28
Figure 9-1 QFN Package Markings.....	29
Figure 9-2 LQFP Package Markings.....	30
Figure 9-4 LQFP-32 Package Dimensions .....	32
Figure 9-5 All packages Reflow Solder Profile .....	33

### List of Tables

Table 3.1 Power and Ground .....	6
Table 3.2 Common Function pins .....	7
Table 3.3 Interface Pins .....	8
Table 3.4 CBUS Configuration Control .....	8
Table 3.5 I/O Configuration.....	9
Table 4.1 I/O Peripherals Signal Names.....	11
Table 4.2 Default Descriptor Strings.....	11
Table 5.1 UART Interface.....	13
Table 5.2 SPI Signal Names .....	14
Table 5.3 - Clock Phase/Polarity Modes.....	15
Table 5.4 Data and Control Bus Signal Mode Options - SPI Slave Interface .....	16
Table 5.5 SPI Master Signal Names.....	17
Table 5.6 SPI Master Timing.....	18
Table 6.1 Error Detection.....	19
Table 7.1 Absolute Maximum Ratings .....	20
Table 7.2 Operating Voltage and Current .....	21
Table 7.3 I/O Pin Characteristics.....	21
Table 7.4 USB I/O Pin (USBDP, USBDM) Characteristics .....	21
Table 7.5 Crystal Oscillator 1.8 Volts DC Characteristics .....	22
Table 7.6 ESD and Latch-up Specifications.....	22



---

Table 9.1	Reflow Profile Parameter Values .....	34
Table 9.2	Package Reflow Peak Temperature.....	34

---

## Appendix C - Revision History

Document Title: USB Android Host IC FT311D  
Document Reference No.: FT\_000660  
Clearance No.: FTDI# 305  
Product Page: <http://www.ftdichip.com/FTProducts.htm>  
Document Feedback: [Send Feedback](#)

**Version 1.0** Initial Release

July 2012

