

FEATURES:

- **Industry Standard ATA/IDE Bus Interface**
 - Host Interface: 16-bit access
 - Supports up to PIO Mode-6
 - Supports up to Multi-word DMA Mode-4
 - Supports up to Ultra DMA Mode-4
- **Interface for Standard NAND Flash Media**
 - Flash Media Interface: Single or Dual 8-bit access
 - Supports up to 4 flash media devices per channel
 - Supports up to 8 flash media devices directly
 - Supports up to 64 flash media devices with external decoding logic
 - Supports Single-Level Cell (SLC) or Multi-Level Cell (MLC) flash media
 - 2 KByte and 4 KByte program page size
- **3.0V Power Supply**
- **5.0V or 3.0V Host Interface Through V_{DDQ} Pins**
- **Low Current Operation:**
 - Active mode: 25 mA/35 mA (3.0V/5.0V) (typical)
 - Sleep mode: 80 μ A/100 μ A (3.0V/5.0V) (typical)
- **Power Management Unit**
 - Immediate disabling of unused circuitry without host intervention
 - Zero wake-up latency
- **Write Protection**
 - WP#/PD# pin configurable by host for prevention of data overwrites
- **20-byte Unique ID for Enhanced Security**
 - Factory Pre-programmed 10-byte Unique ID
 - User-Programmable 10-byte ID
- **Programmable, Multitasking NAND Interface**
- **Firmware Storage in Embedded SuperFlash®**
- **Pre-programmed Embedded Firmware**
 - Performs self-initialization on first system Power-on
 - Executes industry standard ATA/IDE commands
 - Implements dynamic wear-leveling algorithms to substantially increase the longevity of flash media
 - Embedded Flash File System
- **Built-in Hardware ECC**
 - Corrects up to 8 random single-bit errors per 512-byte sector
- **Built-in Internal System Clock**
- **Multi-tasking Technology Enables Fast Sustained Write Performance (Host to Flash)**
 - Supports up to 30 MB/sec
- **Fast Sustained Read Performance (Flash to Host)**
 - Up to 30 MB/sec
- **Automatic Recognition and Initialization of Flash Media Devices**
 - Seamless integration into a standard SMT manufacturing process
 - 5 sec. (typical) for flash drive recognition and setup
- **Commercial and Industrial Temperature Ranges**
 - 0°C to 70°C for commercial operation
 - -40°C to +85°C for industrial operation
- **Packages Available**
 - 100-lead TQFP – 14mm x 14mm
 - 85-ball VFPGA – 6mm x 6mm
- **All non-Pb (lead-free) Devices are RoHS Compliant**

PRODUCT DESCRIPTION

The GLS55VD020 is the heart of a high-performance, flash media-based data storage system. The NAND Controller recognizes the control, address, and data signals on the ATA/IDE bus and translates them into memory accesses for standard NAND-type flash media. Utilizing both Single-Level Cell (SLC) and Multi-Level Cell (MLC) flash media, this technology supports solid state mass storage applications by offering new, expanded functionality while enabling smaller, lighter designs with lower power consumption.

The NAND Controller supports standard ATA/IDE protocol with up to PIO Mode-6, Multi-word DMA Mode-4, and Ultra DMA Mode-4 interface. The ATA/IDE interface is

widely used in such products as portable and desktop computers, portable media player, music players, handheld data collection scanners, PDAs, handy terminals, personal communicators, audio recorders, monitoring devices, and set-top boxes.

The NAND Controller uses SuperFlash® memory technology and is factory pre-programmed with an embedded flash file system. Upon initial power-on, the GLS55VD020 recognizes attached flash media devices, sets up a bad block table, executes all necessary handshaking routines for flash media support, and, finally, performs the low-level format. This process typically takes about 3 second plus 0.5 seconds per gigabyte of drive capacity, allowing a 4

Data Sheet

GByte flash drive to be fully initialized in about 5 seconds. For added manufacturing flexibility, system debug, re-initialization, and user customization can be accomplished through the ATA/IDE interface.

The GLS55VD020 high-performance NAND Controller offers sustained read and write performance up to 30.0 MB/sec. The GLS55VD020 directly supports up to 8 flash media devices or, through simple decoding logic, can support up to 64 flash media devices.

The controller also provides a WP#/PD# pin to protect criti-

cal information stored in the flash media from unauthorized overwrites.

The NAND Controller comes pre-programmed with a 10-byte unique serial ID. For even greater system security, the user has the option of programming an additional 10 Bytes of ID space to create a unique, 20-byte ID.

The NAND Controller comes packaged in an industry-standard, 100-lead TQFP package or a 85-ball VFBGA package for easy integration into an SMT manufacturing process.

GENERAL DESCRIPTION

The NAND Controller contains a microcontroller and embedded flash file system integrated in TQFP and VFBGA packages. Refer to Figure 1 for the NAND Controller block diagram. The controller interfaces with the host system allowing data to be written to and read from the flash media.

Performance-optimized NAND Controller

The NAND Controller translates standard ATA signals into flash media data and control signals. The following components contribute to the NAND Controller's operation.

Microcontroller Unit (MCU)

The MCU coordinates all related components to complete requested operations.

Internal Direct Memory Access (DMA)

The NAND Controller uses internal DMA which allows instant data transfer from buffer to flash media. This increases the data transfer rate by eliminating the microcontroller overhead associated with the traditional, firmware-based approach.

Power Management Unit (PMU)

The power management unit controls the power consumption of the NAND Controller. It reduces the power consumption of the NAND Controller by putting circuitry not in operation into sleep mode. The PMU has zero wake-up latency.

SRAM Buffer

The NAND Controller performs as an SRAM buffer to optimize the host's data transfer to and from the flash media.

Embedded Flash File System

The embedded flash file system is an integral part of the NAND Controller. It contains MCU firmware that performs the following tasks:

1. Translates host side signals into flash media Writes and Reads.
2. Provides dynamic flash media wear-leveling to spread the flash writes across all unused memory address space to increase the longevity of flash media.
3. Keeps track of data file structures.

Error Correction Code (ECC)

The NAND Controller uses BCH Error Detection Code (EDC) and Error Correction Code (ECC) algorithms which correct up to eight random single-bit errors for each 512-byte block of data.

High performance is achieved through hardware-based error detection and correction.

Serial Communication Interface (SCI)

The Serial Communication Interface (SCI) is designed to provide trace information during debugging process. To aid in validation, always provide the SCI access to PCB design.

Programmable, Multi-tasking NAND Interface

The multi-tasking interface enables fast, sustained write and read performance by allowing multiple Read, Program, and Erase operations to multiple flash media devices. The programmable NAND interface enables timely support of fast changing NAND technology.

Data Sheet

FUNCTIONAL BLOCKS

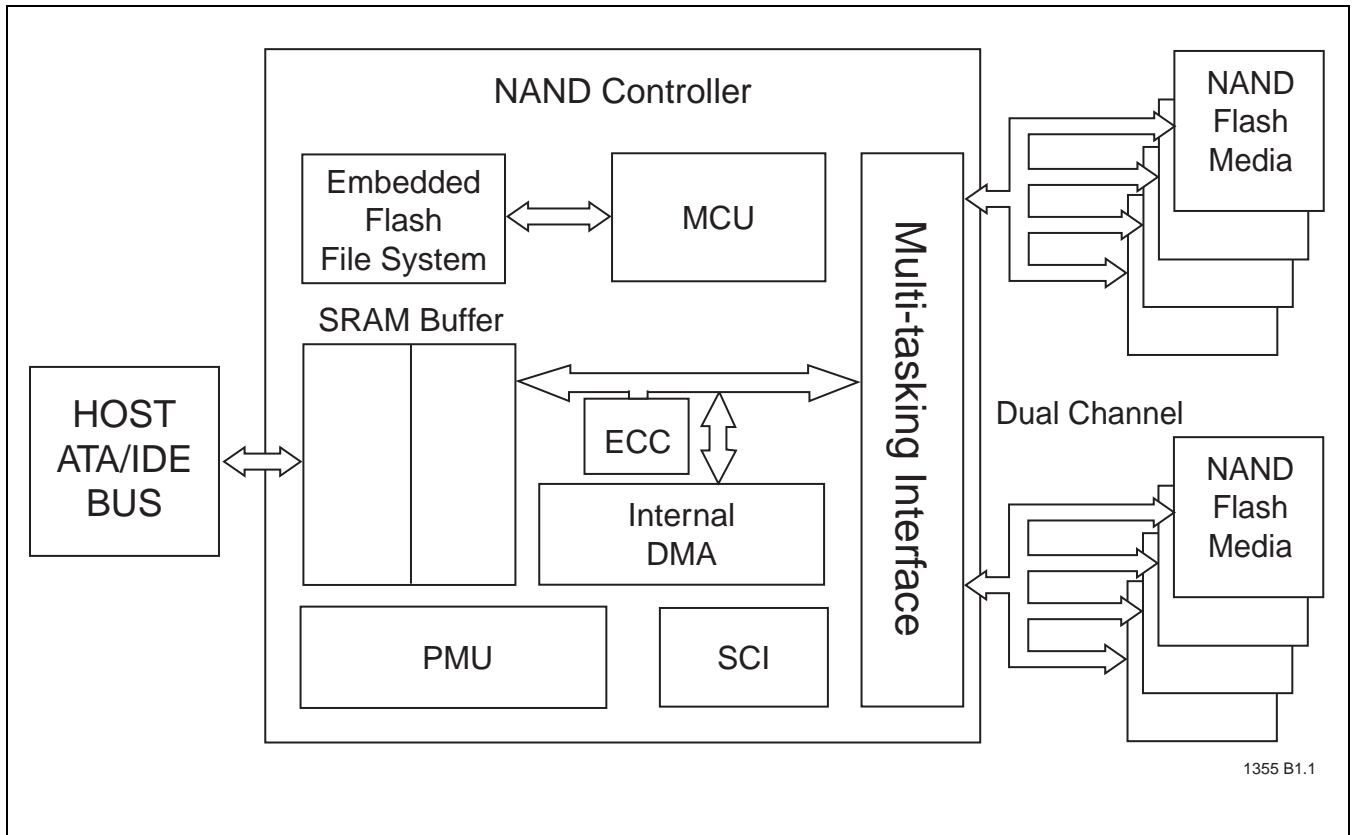

FIGURE 1: NAND CONTROLLER BLOCK DIAGRAM

PIN ASSIGNMENTS

The signal/pin assignments are listed in Table 2. Low active signals have a “#” suffix. Pin types are Input, Output, or Input/Output. Signals whose source is the host are designated as inputs while signals that the NAND Controller sources are outputs.

The NAND Controller functions in ATA mode, which is compatible with IDE hard disk drives.

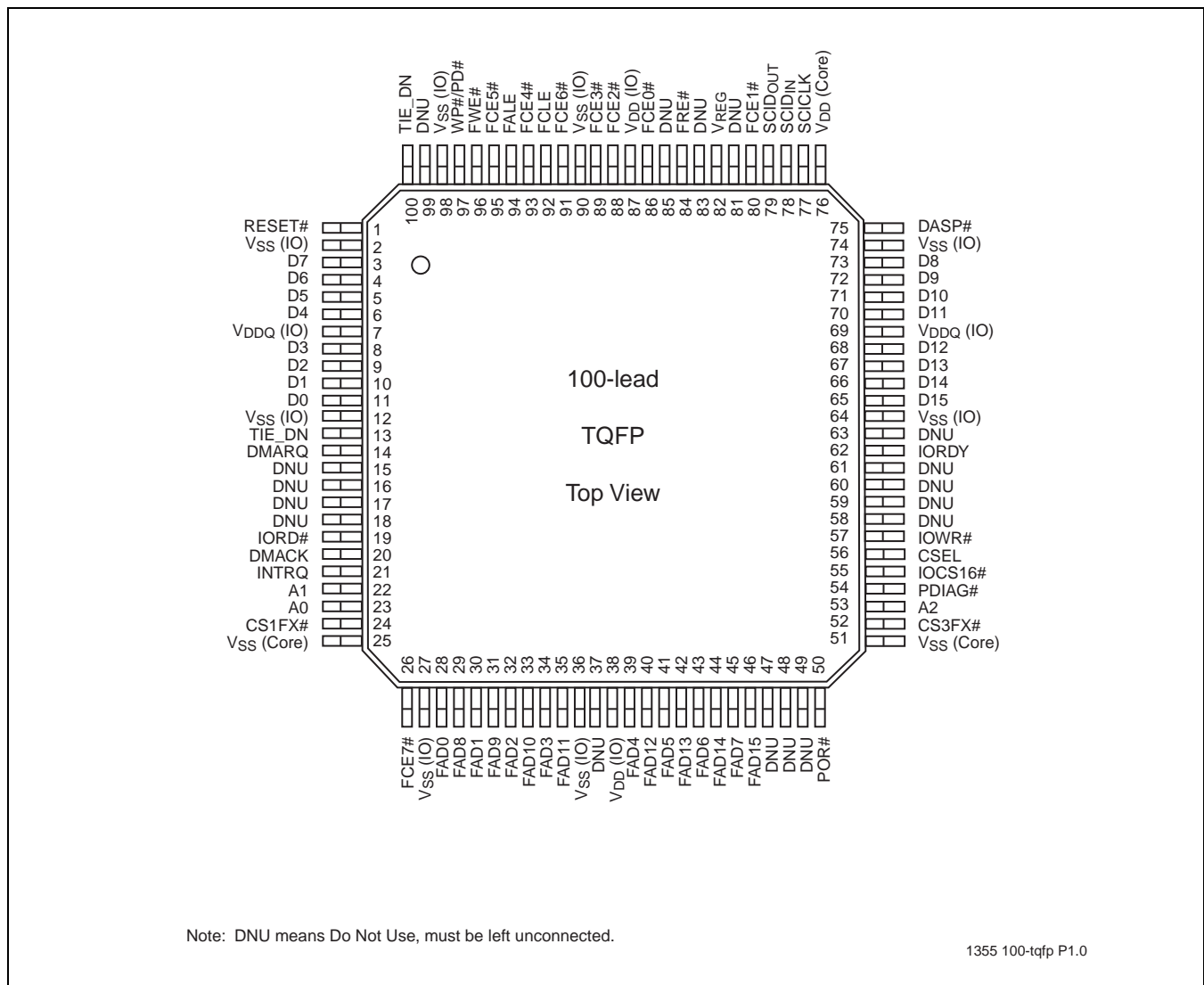

FIGURE 2: PIN ASSIGNMENTS FOR 100-LEAD TQFP (TQW)

Data Sheet

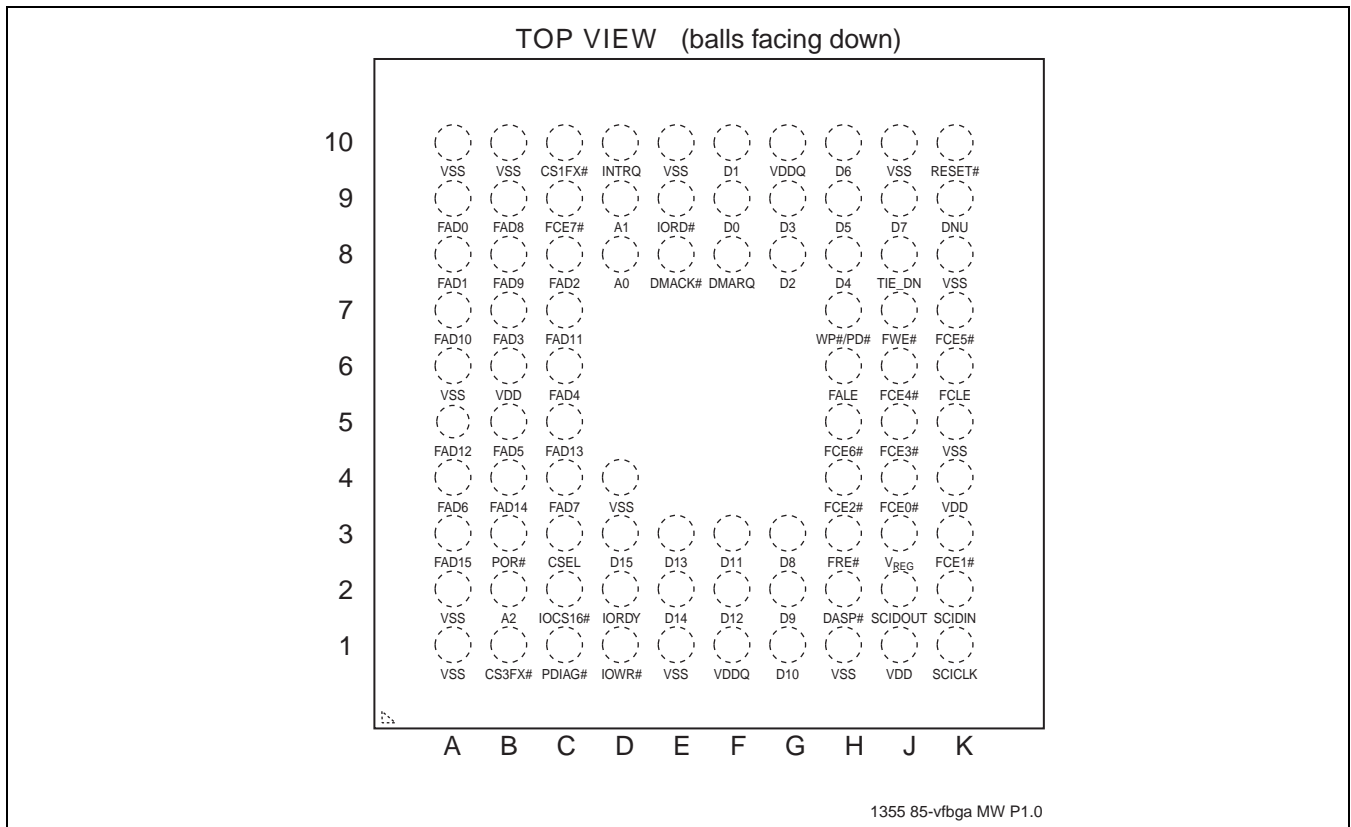

FIGURE 3: PIN ASSIGNMENTS FOR 85-BALL VFBGA (MW)

TABLE 1: PIN ASSIGNMENTS (1 OF 4)

Symbol	Pin No.		Pin Type	I/O Type ¹	Name and Functions
	100-TQFP	85-VFBGA			
Host Side Interface					
A2	53	B2	I	I1Z	A[2:0] are used to select one of eight registers in the Task File.
A1	22	D9			
A0	23	D8			
D15	65	D3	I/O	I1Z/O2	D[15:0] Data bus
D14	66	E2			
D13	67	E3			
D12	68	F2			
D11	70	F3			
D10	71	G1			
D9	72	G2			
D8	73	G3			
D7	3	J9			
D6	4	H10			
D5	5	H9			
D4	6	H8			
D3	8	G9			
D2	9	G8			
D1	10	F10			
D0	11	F9			
DMACK	20	E8	I	I2U	DMA Acknowledge - input from host
DMARQ	14	F8	O	O1	DMA Request to host
IORDY	62	D2	O	O1	IORDY: When Ultra DMA mode DMA Write is not active and the device is not ready to respond to a data transfer request, this signal is negated to extend the Host transfer cycle. However, it is never negated by this controller.
DDMARDY#					DDMARDY#: When Ultra DMA mode DMA Write is active, this signal is asserted by the host to indicate that the device is read to receive Ultra DMA data-in bursts. The device may negate DDMARDY# to pause an Ultra DMA transfer.
DSTROBE					DSTROBE: When Ultra DMA mode DMA Write is active, this signal is the data-out strobe generated by the device. Both the rising and falling edges of DSTROBE cause data to be latched by the host. The device may stop generating DSTROBE edges to pause an Ultra DMA data-out burst.
CS1FX#	24	C10	I	I2Z	CS1FX# is the chip select for the task file registers
CS3FX#	52	B1			CS3FX# is used to select the Alternate Status register and the Device Control register.
CSEL	56	C3	I	I1U	This internally pulled-up signal is used to configure this device as a Master or a Slave. When this pin is grounded, this device is configured as a Master. When the pin is open, or tied to V _{DDQ} , this device is configured as a Slave. The pin setting should remain the same from Power-on to Power-down.

Data Sheet

TABLE 1: PIN ASSIGNMENTS (CONTINUED) (2 OF 4)

Symbol	Pin No.		Pin Type	I/O Type ¹	Name and Functions
	100-TQFP	85-VFBGA			
IORD#	19	E9	I	I2Z	IORD#: This is an I/O Read Strobe generated by the host. When Ultra DMA mode is not active, this signal gates I/O data from the device.
HDMARDY#					HDMARDY#: In Ultra DMA mode when DMA Read is active, this signal is asserted by the host to indicate that the host is ready to receive Ultra DMA data-in bursts. The host may negate HDMARDY# to pause an Ultra DMA transfer.
HSTROBE					HSTROBE: When DMA Write is active, this signal is the data-out strobe generated by the host. Both the rising and falling edges of HSTROBE cause data to be latched by the device. The host may stop generating HSTROBE edges to pause an Ultra DMA data-out burst.
IOWR#	57	D1	I	I2Z	This is an I/O Write Strobe generated by the host. When Ultra DMA mode is not active, this signal is used to clock I/O data into the device.
STOP					When Ultra DMA mode protocol is active, the assertion of this signal causes the termination of the Ultra DMA burst
IOCS16#	55	C2	O	O2	This output signal is asserted low when the device is indicating a word data transfer cycle.
INTRQ	21	D10	O	O1	This signal is the active high Interrupt Request to the host.
PDIAG#	54	C1	I/O	I1U/O1	The Pass Diagnostic signal in the Master/Slave handshake protocol.
DASP#	75	H2	I/O	I1U/O6	The Drive Active/Slave Present signal in the Master/Slave handshake protocol.
RESET#	1	K10	I	I2U	This input pin is the active low hardware reset from the host.
WP#/PD#	97	H7	I	I3U	The WP#/PD# pin can be used for either the Write Protect mode or Power-down mode, but only one mode is active at any time. The Write Protect or Power-down modes can be selected through the host command. The Write Protect mode is the factory default setting. This pin accepts only in the 3.3V V _{DD} signal level.
Flash Media Interface					
FRE#	84	H3	O	O5	Active Low Flash Media Chip Read
FWE#	96	J7			Active Low Flash Media Chip Write
FCLE	92	K6			Active High Flash Media Chip Command Latch Enable
FALE	94	H6			Active High Flash Media Chip Address Latch Enable
FAD15	46	A3	I/O	I3U/O5	Flash Media Chip High Byte Address/Data Bus pins
FAD14	44	B4			
FAD13	42	C5			
FAD12	40	A5			
FAD11	35	C7			
FAD10	33	A7			
FAD9	31	B8			
FAD8	29	B9			

TABLE 1: PIN ASSIGNMENTS (CONTINUED) (3 OF 4)

Symbol	Pin No.		Pin Type	I/O Type ¹	Name and Functions
	100-TQFP	85-VFBGA			
FAD7	45	C4	I/O	I3U/O5	Flash Media Chip Low Byte Address/Data Bus pins
FAD6	43	A4			
FAD5	41	B5			
FAD4	39	C6			
FAD3	34	B7			
FAD2	32	C8			
FAD1	30	A8			
FAD0	28	A9			
FCE7#	26	C9	O	O4	Active Low Flash Media Chip Enable pin
FCE6#	91	H5			
FCE5#	95	K7			
FCE4#	93	J6			
FCE3#	89	J5			
FCE2#	88	H4			
FCE1#	80	K3			
FCE0#	86	J4			
Serial Communication Interface (SCI)					
SCID _{OUT}	79	J2	O	O4	SCI interface data output
SCID _{IN}	78	K2	I	I3U	SCI interface data input
SCICLK	77	K1	I	I3U	SCI interface clock
Miscellaneous					
V _{SS} (IO)	2 12 27 36 64 74 90 98	A2 A6 A10 D4 E1 E10 H1 J10 K5 K8	PWR		Ground for I/O
V _{SS} (Core)	25 51	A1 B10	PWR		Ground for Core
V _{DD} (IO)	38 87	B6 K4	PWR		V _{DD} (3.3V)
V _{DD} (Core)	76	J1	PWR		V _{DD} (3.3V)
V _{DDQ} (IO)	7 69	F1 G10	PWR		V _{DDQ} (5V/3.3V) for Host interface
V _{REG}	82	J3	O		External Capacitor Pin
POR#	50	B3	I	Analog Input ²	Power-on Reset (POR). Active Low
T _{IE_DN}	13 100	J8			Pin needs to be connected to V _{SS} .

Data Sheet

TABLE 1: PIN ASSIGNMENTS (CONTINUED) (4 OF 4)

Symbol	Pin No.		Pin Type	I/O Type ¹	Name and Functions
	100-TQFP	85-VFBGA			
DNU ³	15	K9			Do Not Use, must be left unconnected.
	16				
	17				
	18				
	37				
	47				
	48				
	49				
	58				
	59				
	60				
	61				
	63				
	81				
	83				
85					
99					

T0-0.3 1355

1. IxU = Input with on-chip pull-up.
IxZ = Input without on-chip pull-up.
2. Analog input is connected to V_{DD} for supply voltage detection
3. All DNU pins should not be connected.

CAPACITY SPECIFICATION

Table 2 shows the default capacity and specific settings for heads, sectors, and cylinders. Users can change the default settings in the drive ID table, Table 8, for customization. If the total number of bytes is less than the default, the remaining space could be used as spares to increase the flash drive endurance. It should also be noted that if the total flash drive capacity exceeds the total default number of bytes, the flash drive endurance will be reduced.

TABLE 2: Default ATA Flash Drive Settings

Capacity ¹	Total Bytes	Cylinders ²	Heads ²	Sectors ²	Max LBA
128 MB	128,450,560	490	16	32	250,880
256 MB	256,901,120	980	16	32	501,760
512 MB	512,483,328	993	16	63	1,000,944
1 GB	1,024,966,656	1986	16	63	2,001,888
2 GB	2,048,385,024	3969	16	63	4,000,752
4 GB	4,096,253,952	7937	16	63	8,000,496
6 GB	6,001,164,288	11628	16	63	11,721,024
8 GB	8,001,552,384	15504	16	63	15,628,032
16 GB	16,001,040,384	16383 ³	16	63	31,252,032
32 GB	32,001,048,576	16383 ³	16	63	62,502,048
48 GB	48,002,088,960	16383 ³	16	63	93,754,080
64 GB	64,002,097,152	16383 ³	16	63	125,004,096
96 GB	96,004,177,920	16383 ³	16	63	187,508,160
128 GB	128,004,194,304	16383 ³	16	63	250,008,192

TO-0.5 1355

1. These flash drive capacities can only be manufactured by using the specified version of the NAND Controller.
2. Cylinders, Heads, and Sectors can be re-configured from the default settings during the manufacturing process.
3. Cylinders, Heads, and Sectors are not applicable for these capacities. Only LBA addressing applies.

Functional Specifications

Table 3 shows the performance and the maximum capacity supported by GLS55VD020.

TABLE 3: Functional Specification of GLS55VD020

Functions	GLS55VD020
ATA Controller Supported Capacity	up to 128 GB
ATA Controller Performance-Sustained Write speed	Up to 30.0 MB/sec
ATA Controller Performance-Sustained Read speed	Up to 30.0 MB/sec

TO-0.3 1355

Data Sheet

MANUFACTURING SUPPORT

The NAND Controller firmware contains a list of supported standard NAND flash media devices. Upon initial Power-on, the controller scans all connected flash media devices and reads their device ID. If the device ID matches the listed flash media devices in the NAND Controller, the controller performs drive recognition based on the algorithm provided by the flash media suppliers, including setting up the bad block table, executing all the necessary handshaking routines for flash media support, and, finally, performing the low-level format. For Power-up timing specifications, please refer to Table 13.

Please contact Greenliant for the most current list of supported NAND Flash media devices.

In the event that the NAND flash media device ID is not recognized by the NAND Controller, the user has an option of adding this device to the controller device table through the manufacturing interface provided by Greenliant. Please contact Greenliant for the NAND Controller manufacturing interface software. If the drive initialization fails, and a visual inspection is unable to determine the problem, the GLS55VD020 NAND Controller provides a comprehensive interface for manufacturing flow debug. This interface not only allows debug of the failure and manual reset of the initialization process, but also allows customization of user definable options.

ATA/IDE Interface

The NAND Controller interface can be used for manufacturing support. Greenliant provides an example of a DOS-based solution (an executable routine available from Greenliant) for manufacturing debug and rework.

Serial Communication Interface (SCI)

For additional manufacturing flexibility, the SCI bus can be used to report manufacturing errors. The SCI consists of 3 active signals: SCID_{OUT}, SCID_{IN}, and SCICLK.

Security Features

The GLS55VD020 NAND Controller offers the standard ATA Security Mode Feature Set, a password system that restricts the access of user data stored in the device. For additional data security features, please contact Greenliant.

CONFIGURABLE WRITE PROTECT/POWER-DOWN MODES

The WP#/PD# pin can be used for either Write Protect mode or Power-down mode, but only one mode is active at any time. Either mode can be selected through the host command, Set-WP#/PD#-Mode, explained in Section .

Once the mode is set with this command, the pin will stay in the configured mode until the next time this command is issued. Power-off or reset will not change the configured mode.

Write Protect Mode

When the WP#/PD# pin is configured in the Write Protect mode, the pin offers extended data protection. This feature can be either selected through a jumper or host logic to protect the stored data from inadvertent system writes or erases, and viruses. The Write Protect feature protects the full address space of the data stored on the flash media.

In the Write Protect mode, the WP#/PD# pin should be asserted prior to issuing the destructive commands: Erase-Sector, Format-Track, Write-DMA, Write-Long-Sector, Write-Multiple, Write-Multiple-without-Erase, Write-Sector(s), Write-Sector-without-Erase, or Write-Verify. This will force the NAND Controller to reject any destructive commands from the ATA interface. All destructive commands will return 51H in the Status register and 04H in the Error register signifying an invalid command. All non-destructive commands will be executed normally.

Power-down Mode

When the WP#/PD# is configured in the Power-down mode, if the pin is asserted during a command, the ATA disk controller completes the current command and returns to the standby mode immediately to save power. Afterwards, the device will not accept any other commands. Only a Power-on Reset (POR) or hardware reset will bring the device to normal operation with the WP#/PD# pin de-asserted.

Data Sheet

POWER-ON AND BROWN-OUT RESET CHARACTERISTICS

Power-on and Brown-out Reset circuitry reset the device to a known state. Power-on Reset asserts when the device is turned on. Brown-out Reset asserts when the detected voltage falls below an acceptable level. For more information about the Power-on and Brown-out Reset timing, see Figure 4 and Table 4.

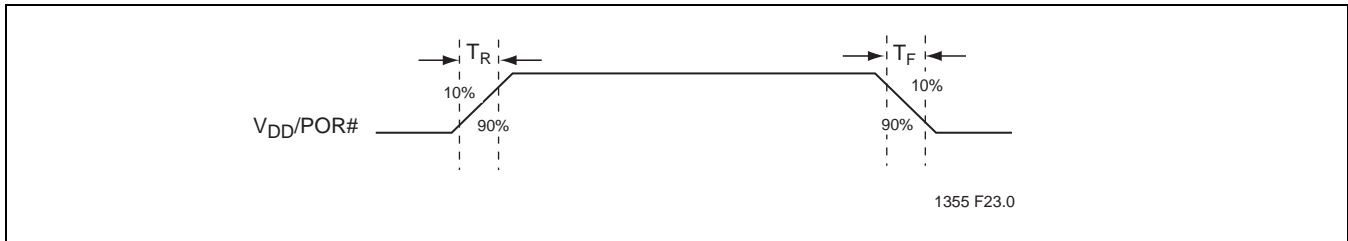

FIGURE 4: Power-on and Brown-out Reset Timing

TABLE 4: Power-on and Brown-out Reset Timing

Item	Symbol	Min	Max	Units
$V_{DD}/POR\#$ Rise Time ¹	T_R		250	ms
$V_{DD}/POR\#$ Fall Time ²	T_F		250	ms

TO-0.0 1355

- V_{DD} Rise Time should be faster than or equal to POR# Rise Time.
- V_{DD} Fall Time should be slower than or equal to POR# Fall Time.

I/O TRANSFER FUNCTION

The default operation for the NAND Controller is 16-bit. However, if the host issues a Set-Feature command to enable 8-bit mode, the NAND Controller permits 8-bit data access.

The following table defines the function of various operations.

TABLE 5: I/O Function

Function Code	CS3FX#	CS1FX#	A0-A2	IORD#	IOWR#	D15-D8	D7-D0
Invalid Mode	V _{IL}	V _{IL}	X	X	X	Undefined	Undefined
Standby Mode	V _{IH}	V _{IH}	X	X	X	High Z	High Z
Task File Write	V _{IH}	V _{IL}	1-7H	V _{IH}	V _{IL}	X	Data In
Task File Read	V _{IH}	V _{IL}	1-7H	V _{IL}	V _{IH}	High Z	Data Out
Data Register Write	V _{IH}	V _{IL}	0	V _{IH}	V _{IL}	In ¹	In
Data Register Read	V _{IH}	V _{IL}	0	V _{IL}	V _{IH}	Out ¹	Out
Control Register Write	V _{IL}	V _{IH}	6H	V _{IH}	V _{IL}	X	Control In
Alt Status Read	V _{IL}	V _{IH}	6H	V _{IL}	V _{IH}	High Z	Status Out

TO-0.0 1355

1. If 8-bit data transfer mode is enabled.

In 8-bit data transfer mode, High Byte is undefined for Data Out. For Data In, X can be V_{IH} or V_{IL}, but no other value.

Data Sheet

SOFTWARE INTERFACE

NAND Controller Drive Register Set Definitions and Protocol

This section defines the drive registers for the NAND Controller and the protocol used to address them.

NAND Controller Addressing

The I/O decoding for an NAND Controller is shown in Table 6.

TABLE 6: Task File Registers

CS3FX#	CS1FX#	A2	A1	A0	Registers	
					IORD# = 0 (IOWR#=1)	IOWR# = 0 (IORD#=1)
1	0	0	0	0	Data (Read)	Data (Write)
1	0	0	0	1	Error	Feature
1	0	0	1	0	Sector Count	Sector Count
1	0	0	1	1	Sector Number (LBA 7-0)	Sector Number (LBA 7-0)
1	0	1	0	0	Cylinder Low (LBA 15-8)	Cylinder Low (LBA 15-8)
1	0	1	0	1	Cylinder High (LBA 23-16)	Cylinder High (LBA 23-16)
1	0	1	1	0	Drive/Head	Drive/Head
1	0	1	1	1	Status	Command
0	1	1	1	0	Alternate Status	Device Control

TO-0.0 1355

NAND Controller Registers

The following section describes the hardware registers used by the host software to issue commands to the NAND Controller. These registers are often collectively referred to as the Task File registers. The registers are only selectable through CS3FX#, CS1FX#, and A₂-A₀ signals.

Data Register (Read/Write) This 16-bit register is used to transfer data blocks between the device data buffer and the host. Data transfer can be performed in PIO mode or DMA mode.

Error Register (Read Only) This register contains additional information about the source of an error when an error is indicated in bit 0 of the Status register. The bits are defined as follows:

D7	D6	D5	D4	D3	D2	D1	D0	Reset Value
ICRC/BBK	UNC	0	IDNF	0	ABRT	0	AMNF	0000 0000b

Symbol	Function
ICRC / BBK	This bit is set when a Bad Block is detected. During an ultra-DMA transfer, this bit is set on detection of a CRC error.
UNC	This bit is set when an Uncorrectable Error is encountered.
IDNF	The requested sector ID is in error or cannot be found.
ABRT	This bit is set if the command has been aborted because of an NAND Controller status condition: (Not Ready, Write Fault, etc.) or when an invalid command has been issued. It is required that the host retry any media access command (such as Read-Sectors and Write-Sectors) that ends with an error condition.
AMNF	This bit is set in case of a general error.

Feature Register (Write Only) This register provides additional command-specific parameters to the NAND Controller.

Sector Count Register This register contains the numbers of sectors of data requested to be transferred on a Read or Write operation between the host and the NAND Controller. If the value in this register is zero, a count of 256 sectors is specified. If the command was successful, this register is zero at command completion. If not successfully completed, the register contains the number of sectors that need to be transferred in order to complete the request.

Sector Number (LBA 7-0) Register This register contains the starting sector number or bits 7-0 of the Logical Block Address (LBA) for any NAND Controller data access for the subsequent command.

Cylinder Low (LBA 15-8) Register This register contains the low order 8 bits of the starting cylinder address or bits 15-8 of the Logical Block Address.

Cylinder High (LBA 23-16) Register This register contains the high order bits of the starting cylinder address or bits 23-16 of the Logical Block Address.

Drive/Head (LBA 27-24) Register The Drive/Head register is used to select the drive and head. It is also used to select LBA addressing instead of cylinder/head/sector addressing. The bits are defined as follows:

D7	D6	D5	D4	D3	D2	D1	D0	Reset Value
1	LBA	1	DRV	HS3	HS2	HS1	HS0	1010 0000b

Symbol	Function
LBA	LBA is a flag to select either Cylinder/Head/Sector (CHS) or Logical Block Address mode (LBA). When LBA=0, Cylinder/Head/Sector mode is selected. When LBA=1, Logical Block Address is selected. In Logical Block mode, the Logical Block Address is interpreted as follows: LBA7-LBA0: Sector Number register D7-D0. LBA15-LBA8: Cylinder Low register D7-D0. LBA23-LBA16: Cylinder High register D7-D0. LBA27-LBA24: Drive/Head register bits HS3-HS0.
DRV	DRV is the drive number. When DRV=0 (Master), Master is selected. When DRV=1 (Slave), Slave is selected.
HS3	When operating in the Cylinder, Head, Sector mode, this is bit 3 of the head number. It is Bit 27 in the Logical Block Address mode.
HS2	When operating in the Cylinder, Head, Sector mode, this is bit 2 of the head number. It is Bit 26 in the Logical Block Address mode.
HS1	When operating in the Cylinder, Head, Sector mode, this is bit 1 of the head number. It is Bit 25 in the Logical Block Address mode.
HS0	When operating in the Cylinder, Head, Sector mode, this is bit 0 of the head number. It is Bit 24 in the Logical Block Address mode.

Status & Alternate Status Registers (Read Only) These registers return the NAND Controller status when read by the host. Reading the Status register does clear a pending interrupt while reading the alternate Status register does not. The meaning of the status bits are described as follows:

D7	D6	D5	D4	D3	D2	D1	D0	Reset Value
BUSY	RDY	DWF	DSC	DRQ	CORR	0	ERR	1000 0000b

Data Sheet

Symbol	Function
BUSY	The busy bit is set when the NAND Controller has access to the command buffer and registers and the host is locked out from accessing the Command register and buffer. No other bits in this register are valid when this bit is set to a 1.
RDY	RDY indicates whether the device is capable of performing NAND Controller operations. This bit is cleared at power up and remains cleared until the NAND Controller is ready to accept a command.
DWF	This bit, if set, indicates a write fault has occurred.
DSC	This bit is set when the NAND Controller is ready.
DRQ	The Data-Request bit is set when the NAND Controller requires that information be transferred either to or from the host through the Data register.
CORR	This bit is set when a correctable data error has been encountered and the data has been corrected. This condition does not terminate a multi-sector Read operation.
ERR	This bit is set when the previous command has ended in some type of error. The bits in the Error register contain additional information describing the error. It is required that the host retry any media access command (such as Read-Sectors and Write-Sectors) that end with an error condition.

Device Control Register (Write Only) This register is used to control the NAND Controller interrupt request and to issue a software reset. This register can be written to even if the device is busy. The bits are defined as follows:

D7	D6	D5	D4	D3	D2	D1	D0	Reset Value
X	X	X	X	1	SW Rst	-IE _n	0	0000 1000 _b

Symbol	Function
SW Rst	This bit is set to 1 in order to force the NAND Controller to perform a software Reset operation. The chip remains in reset until this bit is reset to '0.'
-IE _n	0: The Interrupt Enable bit enables interrupts 1: Interrupts from the NAND Controller are disabled This bit is set to 0 at Power-on and Reset.

Command Register (Write Only) This register contains the command code being sent to the drive. Command execution begins immediately after this register is written. The executable commands, the command codes, and the necessary parameters for each command are listed in Table 7.

NAND Controller Command Description

This section defines the software requirements and the format of the commands the host sends to the NAND Controller. Commands are issued to the NAND Controller by loading the required registers in the command block with the supplied parameters, and then writing the command code to the Command register. With the exception of commands listed in Sections -, NAND Controller complies with ATA-6 Specifications.

NAND Controller Command Set

Table 7 summarizes the NAND Controller command set.

TABLE 7: NAND Controller Command Set (1 of 2)

Command	Code	FR ¹	SC ²	SN ³	CY ⁴	DH ⁵	LBA ⁶
Check-Power-Mode	E5H or 98H	-	-	-	-	D ⁸	-

TABLE 7: NAND Controller Command Set (Continued) (2 of 2)

Command	Code	FR ¹	SC ²	SN ³	CY ⁴	DH ⁵	LBA ⁶
Execute-Drive-Diagnostic	90H	-	-	-	-	D	-
Erase-Sector(s)	C0H	-	Y	Y	Y	Y	Y
Flush-Cache	E7H	-	-	-	-	D	-
Format-Track	50H	-	Y ⁷	-	Y	Y ⁸	Y
Identify-Drive	ECH	-	-	-	-	D	-
Idle	E3H or 97H	-	Y	-	-	D	-
Idle-Immediate	E1H or 95H	-	-	-	-	D	-
Initialize-Drive-Parameters	91H	-	Y	-	-	Y	-
NOP	00H	-	-	-	-	D	-
Read-Buffer	E4H	-	-	-	-	D	-
Read-DMA	C8H or C9H	-	Y	Y	Y	Y	Y
Read-Multiple	C4H	-	Y	Y	Y	Y	Y
Read-Sector(s)	20H or 21H	-	Y	Y	Y	Y	Y
Read-Verify-Sector(s)	40H or 41H	-	Y	Y	Y	Y	Y
Recalibrate	1XH	-	-	-	-	D	-
Request-Sense	03H	-	-	-	-	D	-
Security-Disable-Password	F6H	-	-	-	-	D	-
Security-Erase-Prepare	F3H	-	-	-	-	D	-
Security-Erase-Unit	F4H	-	-	-	-	D	-
Security-Freeze-Lock	F5H	-	-	-	-	D	-
Security-Set-Password	F1H	-	-	-	-	D	-
Security-Unlock	F2H	-	-	-	-	D	-
Seek	7XH	-	-	Y	Y	Y	Y
Set-Features	EFH	Y	-	-	-	D	-
SMART	B0H	Y	Y	Y	Y	D	-
Set-Multiple-Mode	C6H	-	Y	-	-	D	-
Set-Sleep-Mode	E6H or 99H	-	-	-	-	D	-
Set-WP#/PD#-Mode	8BH	Y	-	-	-	D	-
Standby	E2H or 96H	-	-	-	-	D	-
Standby-Immediate	E0H or 94H	-	-	-	-	D	-
Translate-Sector	87H	-	Y	Y	Y	Y	Y
Write-Buffer	E8H	-	-	-	-	D	-
Write-DMA	CAH or CBH	-	Y	Y	Y	Y	Y
Write-Multiple	C5H	-	Y	Y	Y	Y	Y
Write-Multiple-Without-Erase	CDH	-	Y	Y	Y	Y	Y
Write-Sector(s)	30H or 31H	-	Y	Y	Y	Y	Y
Write-Sector(s)-Without-Erase	38H	-	Y	Y	Y	Y	Y
Write-Verify	3CH	-	Y	Y	Y	Y	Y

TO-0.1 1355

- 1.FR - Features register
- 2.SC - Sector Count register
- 3.SN - Sector Number register
- 4.CY - Cylinder registers
- 5.DH - Drive/Head register

Data Sheet

- 6.LBA - Logical Block Address mode supported (see command descriptions for use)
- 7.Y - The register contains a valid parameter for this command.
- 8.For the Drive/Head register:Y means both the NAND Controller and Head parameters are used;
D means only the NAND Controller parameter is valid and not the Head parameter.

Identify-Drive - ECH

Bit ->	7	6	5	4	3	2	1	0
Command (7)	ECH							
C/D/H (6)	X			Drive	X			
Cyl High (5)					X			
Cyl Low (4)					X			
Sec Num (3)					X			
Sec Cnt (2)					X			
Feature (1)					X			

The Identify-Drive command enables the host to receive parameter information from the NAND Controller. This command has the same protocol as the Read-Sector(s) command. The parameter words in the buffer have the arrangement and meanings defined in Table 8. All reserved bits or words are zero. Table 8 gives the definition for each field in the Identify-Drive information.

TABLE 8: Identify-Drive Information (1 of 2)

Word Address	Default Value ¹	Total Bytes	Data Field Type Information
0	044AH	2	General configuration bit
1	bbbbH ²	2	Default number of cylinders
2	0000H	2	Reserved
3	bbbbH ²	2	Default number of heads
4	0000H	2	Reserved
5	XXXXH	2	Vendor Unique
6	bbbbH ²	2	Default number of sectors per track
7-8	bbbbH ³	4	Number of sectors per device (Word 7 = MSW, Word 8 = LSW)
9	xxxxH	2	Vendor Unique
10-14	eeeeH ⁴	10	User-programmable serial number in ASCII
15-19	ddddH ⁵	10	Greenliant preset, unique ID in ASCII
20	0002H	2	Buffer type
21	xxxxH	2	Vendor Unique
22	xxxxH	2	Vendor Unique
23-26	aaaaH ⁶	8	Firmware revision in ASCII. Big Endian Byte Order in Word
27-46	ccccH ⁷	40	User Definable Model number
47	8001H	2	Maximum number of sectors on Read/Write-Multiple command
48	0000H	2	Reserved
49	0B00H	2	Capabilities
50	0000H	2	Reserved
51	0200H	2	PIO data transfer cycle timing mode
52	0000H	2	Reserved
53	0007H	2	Translation parameters are valid
54	nnnnH	2	Current numbers of cylinders
55	nnnnH	2	Current numbers of heads

TABLE 8: Identify-Drive Information (Continued) (2 of 2)

Word Address	Default Value ¹	Total Bytes	Data Field Type Information
56	nnnnH	2	Current sectors per track
57-58	nnnnH	4	Current capacity in sectors (LBAs) (Word 57 = LSW, Word 58 = MSW)
59	010X	2	Multiple sector setting
60-61	nnnnH	4	Total number of sectors addressable in LBA mode
62	0000H	2	Reserved
63	0x07H	2	DMA data transfer is supported in NAND Controller
64	0003H	2	Advanced PIO Transfer mode supported
65	0078H	2	120 ns cycle time support for Multi-word DMA Mode-2
66	0078H	2	120 ns cycle time support for Multi-word DMA Mode-2
67	0078H	2	PIO Mode-4 supported
68	0078H	2	PIO Mode-4 supported
69-79	0000H	22	Reserved
80	007EH	2	ATA/ATAPI major version number
81	0019H	2	ATA/ATAPI minor version number
82	706BH	2	Features/command sets supported
83	400CH	2	Features/command sets supported
84	4000H	2	Features/command sets supported
85-87	xxxxH	6	Features/command sets enabled
88	xx1FH	2	UDMA modes
89	xxxxH	2	Time required for security erase unit completion
90	xxxxH	2	Time required for enhanced security erase unit completion
91-127	0000H	74	Reserved
128	xxxxH	2	Security Status
129-159	0000H	62	Vendor unique bytes
160-162	0000H	6	Reserved
163	xx2H	2	CF Advanced True IDE Timing Mode capabilities and settings
164-255	0000H	184	Reserved

T0-0.4 1355

1. XXXX = This field is subject to change by the host or the device.
2. bbbb - default value set by controller. The selections could be user programmable.
3. n - calculated data based on product configuration
4. eeee - the default value is '0000000000'
5. dddd - unique number of each device
6. aaaa - any unique Greenliant firmware revision
7. cccc - default value is "xxxMB NAND" or "xxxGB NAND" where xxx is the flash drive capacity. The user has an option to change the model number during manufacturing.

Word 0: General Configuration This field informs the host that this is a non-magnetic, hard sectored, removable storage device with a transfer rate greater than 10 MByte/sec and is not MFM encoded.

Word 1: Default Number of Cylinders This field contains the number of translated cylinders in the default translation mode. This value will be the same as the number of cylinders.

Word 3: Default Number of Heads This field contains the number of translated heads in the default translation mode.

Data Sheet

Word 6: Default Number of Sectors per Track This field contains the number of sectors per track in the default translation mode.

Word 7-8: Number of Sectors This field contains the number of sectors per NAND Controller. This double word value is also the first invalid address in LBA translation mode. This field is only required by CF feature set support.

Word 10-19: Serial Number The contents of this field are right justified and padded with spaces (20H). The right-most ten bytes are a Greenliant preset, unique ID. The left-most ten bytes are a user-programmable value with a default value of spaces.

Word 20: Buffer Type This field defines the buffer capability:

0002H: a dual ported multi-sector buffer capable of simultaneous data transfers to or from the host and the NAND Controller.

Word 23-26: Firmware Revision This field contains the revision of the firmware for this product.

Word 27-46: Model Number This field is reserved for the model number for this product.

Word 47: Read-/Write-Multiple Sector Count This field contains the maximum number of sectors that can be read or written per interrupt using the Read-Multiple or Write-Multiple commands. Only a value of '1' is supported.

Word 49: Capabilities BitFunction

13	Standby Timer 0: forces sleep mode when host is inactive.
11	IORDY Support 1: NAND Controller supports PIO Mode-4.
9	LBA support 1: NAND Controller supports LBA mode addressing.
8	DMA Support 1: DMA mode is supported.

Word 51: PIO Data Transfer Cycle Timing Mode This field defines the mode for PIO data transfer. NAND Controller supports up to PIO Mode-4.

Word 53: Translation Parameters Valid BitFunction

0	1: words 54-58 are valid and reflect the current number of cylinders, heads and sectors.
1	1: words 64-70 are valid to support PIO Mode-3 and 4.
2	1: words 88 are valid to support Ultra DMA data transfer.

Word 54-56: Current Number of Cylinders, Heads, Sectors/Track These fields contains the current number of user addressable Cylinders, Heads, and Sectors/Track in the current translation mode.

Word 57-58: Current Capacity This field contains the product of the current cylinders times heads times sectors.

Word 59: Multiple Sector Setting This field contains a validity flag in the Odd Byte and the current number of sectors that can be transferred per interrupt for Read/Write Multiple in the Even Byte. The Odd Byte is always 01H which indicates that the Even Byte is always valid.

The Even Byte value depends on the value set by the Set Multiple command. The Even Byte of this word by default contains a 00H which indicates that Read/Write Multiple commands are not valid.

Word 60-61: Total Sectors Addressable in LBA Mode This field contains the number of sectors addressable for the NAND Controller in LBA mode only.

Word 63: Multi-word DMA Transfer Mode This field identifies the multi-word DMA transfer modes supported by the NAND Controller and indicates the mode that is currently selected. Only one DMA mode can be selected at any given time.

Bit	Function
15-11	Reserved
10	Multi-word DMA mode 2 selected 1: Multi-word DMA mode 2 is selected and bits 8 and 9 are cleared to 0 0: Multi-word DMA mode 2 is not selected.
9	Multi-word DMA mode 1 selected 1: Multi-word DMA mode 1 is selected and 8 and 10 should be cleared to 0. 0: Multi-word DMA mode 1 is not selected.
8	Multi-word DMA mode 0 selected 1: Multi-word DMA mode 0 is selected and bits 9 and 10 are cleared to 0. 0: Multi-word DMA mode 0 is not selected.
7-3	Reserved
2	Multi-word DMA mode 2 supported 1: Multi-word DMA mode 2 and below are supported and Bits 0 and 1 are set to 1.
1	Multi-word DMA mode 1 supported 1: Multi-word DMA mode 1 and below are supported.
0	Multi-word DMA mode 0 supported 1: Multi-word DMA mode 0 is supported.

Word 64: Advanced PIO Data Transfer Mode Bits (7:0) is defined as the PIO data and register transfer supported field. If this field is supported, bit 1 of word 53 shall be set to one. This field is bit significant. Any number of bits may be set to one in this field by the device to indicate the PIO modes the device is capable of supporting. Of these bits, bits (7:2) are Reserved for future PIO modes.

Bit	Function
0	1: NAND Controller supports PIO Mode-3.
1	1: NAND Controller supports PIO Mode-4.

Word 65: Minimum Multi-word DMA Transfer Cycle Time Per Word This field defines the minimum Multi-word DMA transfer cycle time per word. This field defines, in nanoseconds, the minimum cycle time that the NAND Controller supports when performing Multi-word DMA transfers on a per word basis. Greenliant's NAND Controller supports up to Multi-word DMA Mode-2, so this field is set to 120ns.

Word 66: Device Recommended Multi-word DMA Cycle Time This field defines the NAND Controller recommended Multi-word DMA transfer cycle time. This field defines, in nanoseconds, the minimum cycle time per word during a single sector host transfer while performing a multiple sector READ DMA or WRITE DMA command for any location on the media under nominal conditions. If a host runs at a faster cycle rate by operating at a cycle time of less than this value, the NAND Controller may negate DMARQ for flow control. The rate at which DMARQ is negated could result in reduced throughput despite the faster cycle rate. Transfer at

Data Sheet

this rate does not ensure that flow control will not be used, but implies that higher performance may result. Greenliant's NAND Controller supports up to Multi-word DMA Mode-2, so this field is set to 120 ns.

Word 67: Minimum PIO Transfer Cycle Time Without Flow Control This field defines, in nanoseconds, the minimum cycle time that, if used by the host, the device guarantees data integrity during the transfer without utilization of IORDY flow control. If this field is supported, Bit 1 of word 53 shall be set to one. The NAND Controller's minimum cycle time is 120 ns. A value of 0078H is reported.

Word 68: Minimum PIO Transfer Cycle Time With IORDY This field defines, in nanoseconds, the minimum cycle time that the device supports while performing data transfers while utilizing IORDY flow control. If this field is supported, Bit 1 of word 53 shall be set to one. The NAND Controller's minimum cycle time is 120 ns, e.g., PIO Mode-4. A value of 0078H is reported.

Word 80: Major Version Number If not 0000H or FFFFH, the device claims compliance with the major version(s) as indicated by bits (6:1) being set to one. Since ATA standards maintain downward compatibility, a device may set more than one bit. GLS55VD020 supports ATA-1 to ATA-6.

Word 81: Minor Version Number If an implementer claims that the revision of the standard they used to guide their implementation does not need to be reported or if the implementation was based upon a standard prior to the ATA-3 standard, word 81 should be 0000H or FFFFH.

A value of 0019H reported in word 81 indicates ATA/ATAPI-6 T13 1410D revision 3a guided the implementation.

Words 82-84: Features/command sets supported Words 82, 83, and 84 indicate the features and command sets supported. A value of 706BH is reported.

Word 82

Bit	Function
15	0: Obsolete
14	1: NOP command is supported
13	1: Read Buffer command is supported
12	1: Write Buffer command is supported
11	0: Obsolete
10	0: Host Protected Area feature set is not supported
9	0: Device Reset command is not supported
8	0: Service interrupt is not supported
7	0: Release interrupt is not supported
6	1: Look-ahead is supported
5	1: Write cache is supported
4	0: Packet Command feature set is not supported
3	1: Power Management feature set is supported
2	0: Removable Media feature set is not supported
1	1: Security Mode feature set is supported
0	1: SMART feature set is supported

Word 83

The values in this word should not be depended on by host implementers.

Bit	Function
15	0: Provides indication that the features/command sets supported words are not valid
14	1: Provides indication that the features/command sets supported words are valid
13-9	0: Reserved
8	0: Set-Max security extension is not supported
7-5	0: Reserved
4	0: Removable Media Status feature set is not supported
3	1: Advanced Power Management feature set is supported
2	1: CFA feature set is supported
1	0: Read DMA Queued and Write DMA Queued commands are not supported
0	0: Download Microcode command is not supported

Word 84

The values in this word should not be depended on by host implementers.

Bit	Function
15	0: Provides indication that the features/command sets supported words are valid
14	1: Provides indication that the features/command sets supported words are valid
13-0	0: Reserved

Words 85-87: Features/command sets enabled Words 85, 86, and 87 indicate features/command sets enabled. The host can enable/disable the features or command set only if they are supported in Words 82-84.

Word 85

Bit	Function
15	0: Obsolete
14	0: NOP command is not enabled 1: NOP command is enabled
13	0: Read Buffer command is not enabled 1: Read Buffer command is enabled
12	0: Write Buffer command is not enabled 1: Write Buffer command is enabled
11	0: Obsolete
10	1: Host Protected Area feature set is enabled
9	0: Device Reset command is not enabled
8	0: Service interrupt is not enabled
7	0: Release interrupt is not enabled
6	0: Look-ahead is not enabled 1: Look-ahead is enabled
5	0: Write cache is not enabled 1: Write cache is enabled
4	0: Packet Command feature set is not enabled
3	0: Power Management feature set is not enabled 1: Power Management feature set is enabled
2	0: Removable Media feature set is not enabled

Data Sheet

1 0: Security Mode feature set has not been enabled via the Security Set Password command
1: Security Mode feature set has been enabled via the Security Set Password command

0 0: SMART feature set is not enabled

Word 86
Bit Function

15-9 0: Reserved

8 1: Set-Max security extension supported

7-5 0: Reserved

4 0: Removable Media Status feature set is not enabled

3 0: Advanced Power Management feature set is not enabled

2 0: CFA feature set is disabled

1 0: Read DMA Queued and Write DMA Queued commands are not enabled

0 0: Download Microcode command is not enabled

Word 87

The values in this word should not be depended on by host implementers.

Bit Function

15 0: Provides indication that the features/command sets supported words are valid

14 1: Provides indication that the features/command sets supported words are valid

13-0 0: Reserved

Word 88
Bit Function

15-13 Reserved

12 1: Ultra DMA mode 4 is selected
0: Ultra DMA mode 4 is not selected

11 1: Ultra DMA mode 3 is selected
0: Ultra DMA mode 3 is not selected

10 1: Ultra DMA mode 2 is selected
0: Ultra DMA mode 2 is not selected

9 1: Ultra DMA mode 1 is selected
0: Ultra DMA mode 1 is not selected

8 1: Ultra DMA mode 0 is selected
0: Ultra DMA mode 0 is not selected

7-5 Reserved

4 1: Ultra DMA mode 4 and below are supported

3 1: Ultra DMA mode 3 and below are supported

2 1: Ultra DMA mode 2 and below are supported

1 1: Ultra DMA mode 1 and below are supported

0 1: Ultra DMA mode 0 is supported

Word 89: Time required for Security erase unit completion Word 89 specifies the time required for the Security Erase Unit command to complete.

Value	Time
0	Value not specified
1-254	(Value * 2) minutes
255	>508 minutes

Word 90: Time required for Enhanced security erase unit completion Word 90 specifies the time required for the Enhanced Security Erase Unit command to complete.

Value	Time
0	Value not specified
1-254	(Value * 2) minutes
255	>508 minutes

Word 128: Security Status BitFunction

- 8 Security Level
 1: Security mode is enabled and the security level is maximum
 0: and security mode is enabled, indicates that the security level is high
- 5 Enhanced security erase unit feature supported
 1: Enhanced security erase unit feature set is supported
- 4 Expire
 1: Security count has expired and Security Unlock and Security Erase Unit are command aborted until a Power-on reset or hard reset
- 3 Freeze
 1: Security is frozen
- 2 Lock
 1: Security is locked
- 1 Enable/Disable
 1: Security is enabled
 0: Security is disabled
- 0 Capability
 1: NAND Controller supports security mode feature set
 0: NAND Controller does not support security mode feature set

Word 163: CF Advanced True IDE Timing Mode Capabilities and Settings This word describes the capabilities and current settings for CF modes utilizing the True IDE interface.

Four separate fields determine support and selection options in the Advanced PIO and Advanced Multiword DMA timing modes. For information on the older modes, see “Word 63: Multi-word DMA Transfer Mode” on page 23. and “Word 64: Advanced PIO Data Transfer Mode” on page 23.. When the Identity drive command executes, the device returns 0492H.

Bit Function

Data Sheet

2-0

Advanced True IDE PIO Mode Support

Indicates the maximum True IDE PIO mode supported by the card

Value	Time
0	Specified in word 64
1	PIO Mode 5
2	PIO Mode 6
3-7	Reserved

5-3

Advanced True IDE Multiword DMA Mode Support

Indicates the maximum True IDE Multiword DMA mode supported by the card

Value	Time
0	Specified in word 63
1	Multiword DMA Mode 3
2	Multiword DMA Mode 4
3-7	Reserved

8-6 Advanced True IDE PIO Mode Selected
Indicates the current True IDE PIO mode selected on the card

Value	Time
0	Specified in word 64
1	PIO Mode 5
2	PIO Mode 6
3-7	Reserved

11-9 Advanced True IDE Multiword DMA Mode Selected
Indicates the current True IDE Multiword DMA mode selected on the card

Value	Time
0	Specified in word 63
1	Multiword DMA Mode 3
2	Multiword DMA Mode 4
3-7	Reserved

15-12 Reserved

Set-Features - EFH

Bit ->	7	6	5	4	3	2	1	0
Command (7)	EFH							
C/D/H (6)	X			Drive	X			
Cyl High (5)	X							
Cyl Low (4)	X							
Sec Num (3)	X							
Sec Cnt (2)	Config							
Feature (1)	Feature							

This command is used by the host to establish or select certain features. Table 9 defines all features that are supported.

TABLE 9: Features Supported

Feature	Operation
01H	Enable 8-bit data transfers.
02H	Enable Write cache
03H	Set transfer mode based on value in Sector Count register. Table 10 defines the values.
09H	Enable Extended Power Operations
55H	Disable Read Look Ahead.
66H	Disable Power-on Reset (POR) establishment of defaults at software reset.
69H	NOP - Accepted for backward compatibility.
81H	Disable 8-bit data transfer.
82H	Disable Write Cache
89H	Disable Extended Power operations
96H	NOP - Accepted for backward compatibility.
97H	Accepted for backward compatibility. Use of this Feature is not recommended.

Data Sheet

TABLE 9: Features Supported

Feature	Operation
AAH	Enable Read-Look-Ahead
CCH	Enable Power-on Reset (POR) establishment of defaults at software reset.

TO-0.0 1355

Features 01H and 81H are used to enable and clear 8-bit data transfer mode. If the 01H feature command is issued all data transfers will occur on the low order D₇-D₀ data bus and the IOCS16# signal will not be asserted for data register accesses.

Features 02H and 82H allow the host to enable or disable write cache in the NAND Controllers that implement write cache. When the subcommand Disable-Write-Cache is issued, the NAND Controller should initiate the sequence to flush cache to non-volatile memory before command completion.

Feature 03H allows the host to select the transfer mode by specifying a value in the Sector Count register. The upper 5 bits define the type of transfer and the low order 3 bits encode the mode value. One PIO mode is selected at all times. The host may change the selected modes by the Set-Features command.

Feature 55H is the default feature for the NAND Controller. Therefore, the host does not have to issue Set-Features command with this feature unless it is necessary for compatibility reasons.

Features 66H and CCH can be used to enable and disable whether the Power-on Reset (POR) Defaults will be set when a software reset occurs.

TABLE 10: Transfer Mode Values

Mode	Bits [7:3]	Bits [2:0]
PIO default mode	00000b	000b
PIO default mode, disable IORDY	00000b	001b
PIO flow control transfer mode	00001b	mode ¹
Multi-word DMA mode	00100b	mode ¹
Ultra-DMA mode	01000b	mode ¹
Reserved	Other	N/A

T0-0.1 1355

1. Mode = transfer mode number, all other values are not valid

Idle - 97H or E3H

Bit ->	7	6	5	4	3	2	1	0	
Command (7)	97H or E3H								
C/D/H (6)	X		Drive		X				
Cyl High (5)					X				
Cyl Low (4)					X				
Sec Num (3)					X				
Sec Cnt (2)	Timer Count (5 msec increments)								
Feature (1)					X				

This command causes the NAND Controller to set BSY, enter the Idle mode, clear BSY and generate an interrupt. If the sector count is non-zero, it is interpreted as a timer count with each count being 5 milliseconds and the automatic Power-down mode is enabled. If the sector count is zero, the automatic Power-down mode is also enabled, the timer count is set to 3, with each count being 5 ms. Note that this time base (5 msec) is different from the ATA specification.

Set-Sleep-Mode - 99H or E6H

Bit ->	7	6	5	4	3	2	1	0	
Command (7)	99H or E6H								
C/D/H (6)	X		Drive		X				
Cyl High (5)					X				
Cyl Low (4)					X				
Sec Num (3)					X				
Sec Cnt (2)					X				
Feature (1)					X				

This command causes the NAND Controller to set BSY, enter the Sleep mode, clear BSY and generate an interrupt. Recovery from sleep mode is accomplished by simply issuing another command (a reset is permitted but not required). Sleep mode is also entered when internal timers expire so the host does not need to issue this command except when it wishes to enter Sleep mode immediately. The default value for the timer is 15 milliseconds.

Set-WP#/PD#-Mode - 8BH

Bit ->	7	6	5	4	3	2	1	0
Command (7)	8BH							

Data Sheet

Bit ->	7	6	5	4	3	2	1	0
C/D/H (6)		X		Drive			X	
Cyl High (5)	6EH							
Cyl Low (4)	44H							
Sec Num (3)	72H							
Sec Cnt (2)	50H							
Feature (1)	55H or AAH							

This command configures the WP#/PD# pin for either the Write Protect mode or the Power-down mode. When the host sends this command to the device with the value AAH in the feature register, the WP#/PD# pin is configured for the Write Protect mode described in Section . The Write Protect mode is the factory default setting. When the host sends this command to the device with the value 55H in the feature register, WP#/PD# is configured for the Power-down mode.

All values in the C/D/H register, the Cylinder Low register, the Cylinder High register, the Sector Number register, the Sector Count register, and the Feature register need to match the values shown above, otherwise, the command will be treated as an invalid command.

Once the mode is set with this command, the device will stay in the configured mode until the next time this command is issued. Power-off or reset will not change the configured mode.

Error Posting

The following table summarizes the valid status and error values for the NAND Controller command set.

TABLE 11: Error and Status Register¹ (1 of 2)

Command	Error Register					Status Register				
	BBK	UNC	IDNF	ABRT	AMNF	RDY	DWF	DSC	CORR	ERR
Check-Power-Mode				V		V	V	V		V
Execute-Drive-Diagnostic						V		V		V
Erase-Sector(s)	V		V	V	V	V	V	V		V
Flush-Cache				V		V	V	V		V
Format-Track			V	V	V	V	V	V		V
Identify-Drive				V		V	V	V		V
Idle				V		V	V	V		V
Idle-Immediate				V		V	V	V		V
Initialize-Drive-Parameters						V		V		V
NOP				V		V	V			V
Read-Buffer				V		V	V	V		V
Read-DMA	V	V	V	V	V	V	V	V	V	V
Read-Multiple	V	V	V	V	V	V	V	V	V	V
Read-Sector(s)	V	V	V	V	V	V	V	V	V	V
Read-Verify-Sector(s)	V	V	V	V	V	V	V	V	V	V
Recalibrate				V		V	V	V		V
Request-Sense				V		V		V		V
Security-Disable-Password				V		V	V	V		V

TABLE 11: Error and Status Register¹ (Continued) (2 of 2)

Command	Error Register					Status Register				
	BBK	UNC	IDNF	ABRT	AMNF	RDY	DWF	DSC	CORR	ERR
Security-Erase-Prepare				V		V	V	V		V
Security-Erase-Unit				V		V	V	V		V
Security-Freeze-Lock				V		V	V	V		V
Security-Set-Password				V		V	V	V		V
Security-Unlock				V		V	V	V		V
Seek			V	V		V	V	V		V
Set-Features				V		V	V	V		V
Set-Multiple-Mode				V		V	V	V		V
Set-Sleep-Mode				V		V	V	V		V
Set-WP#/PD#-Mode				V		V		V		V
SMART			V	V		V	V	V		V
Standby				V		V	V	V		V
Standby-Immediate				V		V	V	V		V
Translate-Sector	V		V	V	V	V	V	V		V
Write-Buffer				V		V	V	V		V
Write-DMA	V		V	V	V	V	V	V		V
Write-Multiple	V		V	V	V	V	V	V		V
Write-Multiple-Without-Erase	V		V	V	V	V	V	V		V
Write-Sector(s)	V		V	V	V	V	V	V		V
Write-Sector(s)-Without-Erase	V		V	V	V	V	V	V		V
Write-Verify	V		V	V	V	V	V	V		V
Invalid-Command-Code				V		V	V	V		V

T0-0.3 1355

1. The host is required to reissue any media access command (such as Read-Sector and Write Sector) that ends with an error condition.

Data Sheet

ELECTRICAL SPECIFICATIONS

Absolute Maximum Stress Ratings (Applied conditions greater than those listed under “Absolute Maximum Stress Ratings” may cause permanent damage to the device. This is a stress rating only and functional operation of the device at these conditions or conditions greater than those defined in the operational sections of this data sheet is not implied. Exposure to absolute maximum stress rating conditions may affect device reliability.)

Temperature Under Bias	-55°C to +125°C
Storage Temperature	-65°C to +150°C
D.C. Voltage on Pins ¹ I3, I4, O4, and O5 to Ground Potential	-0.5V to V _{DD} +0.5V
Transient Voltage (<20 ns) on Pins ¹ I3, I4, O4, and O5 to Ground Potential	-2.0V to V _{DD} +2.0V
D.C. Voltage on Pins ¹ I1, I2, O1, O2, and O6 to Ground Potential	-0.5V to V _{DDQ} +0.5V
Transient Voltage (<20 ns) on Pins ¹ I1, I2, O1, O2, and O6 to Ground Potential	-2.0V to V _{DDQ} +2.0V
Package Power Dissipation Capability (T _A = 25°C)	1.0W
Through Hole Lead Soldering Temperature (10 Seconds)	300°C
Surface Mount Solder Reflow Temperature	260°C for 10 seconds
Output Short Circuit Current ²	50 mA

1. Please refer to Table 1 for pin assignment information.
2. Outputs shorted for no more than one second. No more than one output shorted at a time.

TABLE 12: Absolute Maximum Power Pin Stress Ratings

Parameter	Symbol	Conditions
Input Power	V _{DDQ} V _{DD}	-0.3V min to 6.5V max -0.3V min to 4.0V max
Voltage on any flash media interface pin with respect to V _{SS}		-0.5V min to V _{DD} + 0.5V max
Voltage on all other pins with respect to V _{SS}		-0.5V min to V _{DDQ} + 0.5V max

TO-0.0 1355

OPERATING RANGE

Range	Ambient Temperature	V _{DDQ}					
		V _{DD}				5V	
		3V		3.3V			
		Min	Max	Min	Max	Min	Max
Commercial	0°C to +70°C	2.7V	3.465V	3.135V	3.465V	4.5V	5.5V
Industrial	-40°C to +85°C	2.7V	3.465V	3.135V	3.465V	4.5V	5.5V

AC CONDITIONS OF TEST

Input Rise/Fall Time	10 ns
Output Load Media	C _L = 100 pF for 3.3V / 80 pF for 3V
Output Load Host	C _L = 100 pF for 3.3V and 5.0V / 80 pF for 3V
See Figure 5	

Note: All AC specifications are guaranteed by design.

TABLE 13: Recommended System Power-on Timing

Symbol	Parameter	Typical	Maximum	Units
T _{PU-INITIAL}	Drive Initialization to Ready	3 sec + (0.5 sec/ GByte)	100	sec
T _{PU-READY1} ¹	Host Power-on/Reset to Ready Operation	200	1000	ms
T _{PU-WRITE1} ¹	Host Power-on/Reset to Write Operation	200	1000	ms

T0-0.3 1355

1. This parameter is measured only for initial qualification and after a design or process change that could affect this parameter.

TABLE 14: Capacitance (Ta = 25°C, f=1 MHz, other pins open)

Parameter	Description	Test Condition	Maximum
C _{I/O} ¹	I/O Pin Capacitance	V _{I/O} = 0V	10 pF
C _{IN} ¹	Input Capacitance	V _{IN} = 0V	10 pF

T0-0.0 1355

1. This parameter is measured only for initial qualification and after a design or process change that could affect this parameter.

TABLE 15: Reliability Characteristics

Symbol	Parameter	Minimum Specification	Units	Test Method
I _{LTH} ¹	Latch Up	100 + I _{DD}	mA	JEDEC Standard 78

T0-0.0 1355

1. This parameter is measured only for initial qualification and after a design or process change that could affect this parameter.

DC Characteristics

TABLE 16: DC Characteristics for Media Interface V_{DD} = 3.3V

Symbol	Type	Parameter	Min	Max	Units	Conditions
V _{IH3} V _{IL3}	I3	Input Voltage	2.0	0.8	V	V _{DD} =V _{DD} Max V _{DD} =V _{DD} Min
I _{IL3}	I3Z	Input Leakage Current	-10	10	uA	V _{IN} = GND to V _{DD} , V _{DD} = V _{DD} Max
I _{U3}	I3U	Input Pull-Up Current	-160	-10	uA	V _{IN} = GND, V _{DD} = V _{DD} Max
V _{T+4} V _{T-4}	I4	Input Voltage Schmitt Trigger	0.8	2.0	V	V _{DD} = V _{DD} Max V _{DD} = V _{DD} Min
I _{IL4}	I4Z	Input Leakage Current	-10	10	uA	V _{IN} = GND to V _{DD} , V _{DD} = V _{DD} Max
V _{OH4} V _{OL4}	O4	Output Voltage	2.4	0.4	V	I _{OH4} =I _{OH4} Min I _{OL4} =I _{OL4} Max
I _{OH4}		Output Current	-2		mA	V _{DD} =V _{DD} Min
I _{OL4}		Output Current		2	mA	V _{DD} =V _{DD} Min
V _{OH5} V _{OL5}	O5	Output Voltage	2.4	0.4	V	I _{OH5} =I _{OH5} Min I _{OL5} =I _{OL5} Max
I _{OH5}		Output Current	-4		mA	V _{DD} =V _{DD} Min
I _{OL5}		Output Current		4	mA	V _{DD} =V _{DD} Min

T0-0.0 1355

Data Sheet

TABLE 17: DC Characteristics for Media Interface $V_{DD} = 3.0V$

Symbol	Type	Parameter	Min	Max	Units	Conditions
V_{IH3} V_{IL3}	I3	Input Voltage	2.0	0.8	V	$V_{DD}=V_{DD} \text{ Max}$ $V_{DD}=V_{DD} \text{ Min}$
I_{IL3}	I3Z	Input Leakage Current	-10	10	μA	$V_{IN} = \text{GND to } V_{DD}$, $V_{DD} = V_{DD} \text{ Max}$
I_{U3}	I3U	Input Pull-Up Current	-160	-10	μA	$V_{IN} = \text{GND}$, $V_{DD} = V_{DD} \text{ Max}$
V_{T+4} V_{T-4}	I4	Input Voltage Schmitt Trigger	0.8	2.0	V	$V_{DD} = V_{DD} \text{ Max}$ $V_{DD} = V_{DD} \text{ Min}$
I_{IL4}	I4Z	Input Leakage Current	-10	10	μA	$V_{IN} = \text{GND to } V_{DD}$, $V_{DD} = V_{DD} \text{ Max}$
V_{OH4} V_{OL4}	O4	Output Voltage	2.2	0.4	V	$I_{OH4}=I_{OH4} \text{ Min}$ $I_{OL4}=I_{OL4} \text{ Max}$
I_{OH4}		Output Current	-1.2		mA	$V_{DD}=V_{DD} \text{ Min}$
I_{OL4}		Output Current		1.2	mA	$V_{DD}=V_{DD} \text{ Min}$
V_{OH5} V_{OL5}	O5	Output Voltage	2.2	0.4	V	$I_{OH5}=I_{OH5} \text{ Min}$ $I_{OL5}=I_{OL5} \text{ Max}$
I_{OH5}		Output Current	-2		mA	$V_{DD}=V_{DD} \text{ Min}$
I_{OL5}		Output Current		2	mA	$V_{DD}=V_{DD} \text{ Min}$

TO-0.0 1355

TABLE 18: DC Characteristics for Host Interface $V_{DDQ} = 3.3V$ or $V_{DDQ} = 5V$

Symbol	Type	Parameter	Min	Max	Units	Conditions
V_{IH1} V_{IL1}	I1	Input Voltage	2.0	0.8	V	$V_{DDQ}=V_{DDQ} \text{ Max}$ $V_{DDQ}=V_{DDQ} \text{ Min}$
I_{IL1}	I1Z	Input Leakage Current	-10	10	μA	$V_{IN} = \text{GND to } V_{DDQ}$, $V_{DDQ} = V_{DDQ} \text{ Max}$
I_{U1}	I1U	Input Pull-Up Current	-150	-6	μA	$V_{OUT} = \text{GND}$, $V_{DDQ} = V_{DDQ} \text{ Max}$
V_{T+2} V_{T-2}	I2	Input Voltage Schmitt Trigger	0.8	2.0	V	$V_{DDQ}=V_{DDQ} \text{ Max}$ $V_{DDQ}=V_{DDQ} \text{ Min}$
I_{IL2}	I2Z	Input Leakage Current	-10	10	μA	$V_{IN} = \text{GND to } V_{DDQ}$, $V_{DDQ} = V_{DDQ} \text{ Max}$
I_{U2}	I2U	Input Pull-Up Current	-150	-6	μA	$V_{OUT} = \text{GND}$, $V_{DDQ} = V_{DDQ} \text{ Max}$
V_{OH1} V_{OL1}	O1	Output Voltage	2.4	0.4	V	$I_{OH1}=I_{OH1} \text{ Min}$ $I_{OL1}=I_{OL1} \text{ Max}$
I_{OH1}		Output Current	-4		mA	$V_{DDQ}=V_{DDQ} \text{ Min}$
I_{OL1}		Output Current		4	mA	$V_{DDQ}=V_{DDQ} \text{ Min}$
V_{OH2} V_{OL2}	O2	Output Voltage	2.4	0.4	V	$I_{OH2}=I_{OH2} \text{ Min}$ $I_{OL2}=I_{OL2} \text{ Max}$
I_{OH2}		Output Current	-8		mA	$V_{DDQ}=2.7V$
I_{OL2}		Output Current		8	mA	$V_{DDQ} \text{ Min}$
V_{OH6} V_{OL6}	O6	Output Voltage for DASP# pin	2.4	0.4	V	$I_{OH6}=I_{OH6} \text{ Min}$ $I_{OL6}=I_{OL6} \text{ Max}$
I_{OH6}		Output Current for DASP# pin	-4		mA	$V_{DDQ}=2.7-3.465V$
I_{OL6}		Output Current for DASP# pin		12	mA	$V_{DDQ}=2.7-3.465V$
I_{OH6}		Output Current for DASP# pin	-4		mA	$V_{DDQ}=4.5V-5.5V$
I_{OL6}		Output Current for DASP# pin		12	mA	$V_{DDQ}=4.5V-5.5V$

T0-0.1 1355

Data Sheet

TABLE 19: DC Characteristics for Host Interface $V_{DDQ} = 3.0V$

Symbol	Type	Parameter	Min	Max	Units	Conditions
V_{IH1} V_{IL1}	I1	Input Voltage	2.0	0.8	V	$V_{DDQ}=V_{DDQ} \text{ Max}$ $V_{DDQ}=V_{DDQ} \text{ Min}$
I_{IL1}	I1Z	Input Leakage Current	-10	10	μA	$V_{IN} = \text{GND to } V_{DDQ}$, $V_{DDQ} = V_{DDQ} \text{ Max}$
I_{U1}	I1U	Input Pull-Up Current	-150	-6	μA	$V_{OUT} = \text{GND}$, $V_{DDQ} = V_{DDQ} \text{ Max}$
V_{T+2} V_{T-2}	I2	Input Voltage Schmitt Trigger	0.8	2.0	V	$V_{DDQ}=V_{DDQ} \text{ Max}$ $V_{DDQ}=V_{DDQ} \text{ Min}$
I_{IL2}	I2Z	Input Leakage Current	-10	10	μA	$V_{IN} = \text{GND to } V_{DDQ}$, $V_{DDQ} = V_{DDQ} \text{ Max}$
I_{U2}	I2U	Input Pull-Up Current	-150	-6	μA	$V_{OUT} = \text{GND}$, $V_{DDQ} = V_{DDQ} \text{ Max}$
V_{OH1} V_{OL1}	O1	Output Voltage	2.2	0.4	V	$I_{OH1}=I_{OH1} \text{ Min}$ $I_{OL1}=I_{OL1} \text{ Max}$
I_{OH1}		Output Current	-2		mA	$V_{DDQ}=V_{DDQ} \text{ Min}$
I_{OL1}		Output Current		2	mA	$V_{DDQ}=V_{DDQ} \text{ Min}$
V_{OH2} V_{OL2}	O2	Output Voltage	2.2	0.4	V	$I_{OH2}=I_{OH2} \text{ Min}$ $I_{OL2}=I_{OL2} \text{ Max}$
I_{OH2}		Output Current	3		mA	$V_{DDQ} \text{ Min}$
I_{OL2}		Output Current		3	mA	$V_{DDQ} \text{ Min}$
V_{OH6} V_{OL6}	O6	Output Voltage for DASP# pin	2.2	0.4	V	$I_{OH6}=I_{OH6} \text{ Min}$ $I_{OL6}=I_{OL6} \text{ Max}$
I_{OH6}		Output Current for DASP# pin	-2		mA	$V_{DDQ} \text{ Min}$
I_{OL6}		Output Current for DASP# pin		8	mA	$V_{DDQ} \text{ Max}$

TO-0.1 1355

TABLE 20: Power Consumption

Symbol	Type	Parameter	Min	Max	Units	Conditions
$I_{DD}^{1,2}$	PWR	Power supply current ($T_A = 0^\circ C$ to $+70^\circ C$)		50	mA	$V_{DD}=V_{DD} \text{ Max}$; $V_{DDQ}=V_{DDQ} \text{ Max}$
$I_{DD}^{1,2}$	PWR	Power supply current ($T_A = -40^\circ C$ to $+85^\circ C$)		100	mA	$V_{DD}=V_{DD} \text{ Max}$; $V_{DDQ}=V_{DDQ} \text{ Max}$
I_{SP}	PWR	Sleep/Standby/Idle current ($T_A = 0^\circ C$ to $+70^\circ C$)		700	μA	$V_{DD}=V_{DD} \text{ Max}$; $V_{DDQ}=V_{DDQ} \text{ Max}$
I_{SP}	PWR	Sleep/Standby/Idle current ($T_A = -40^\circ C$ to $+85^\circ C$)		950	μA	$V_{DD}=V_{DD} \text{ Max}$; $V_{DDQ}=V_{DDQ} \text{ Max}$

TO-0.1 1355

- Sequential data transfer for 1 sector read data from host interface and write data to media.
- This parameter is measured only for initial qualification and after a design or process change that could affect this parameter.

AC Characteristics

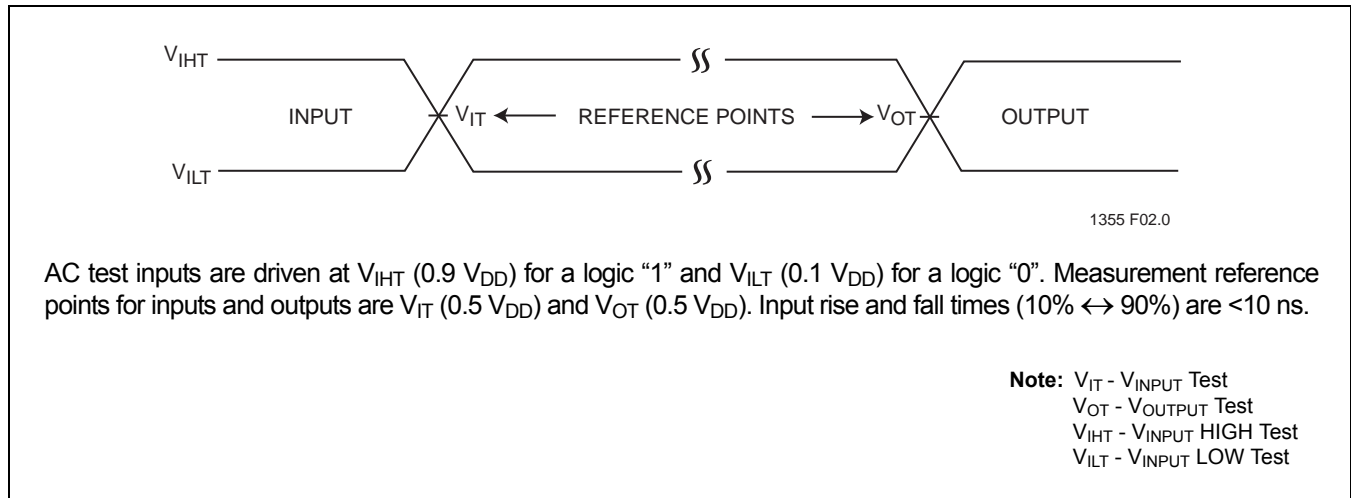

FIGURE 5: AC Input/Output Reference Waveforms

Media Side Interface Timing Specifications

TABLE 21: GLS55VD020 Timing Specifications

Symbol	Parameter	Min	Max	Units
T_{CLS}	FCLE Setup Time	15	-	ns
T_{CLH}	FCLE Hold Time	15	-	ns
T_{CS}	FCE# Setup Time	30	-	ns
T_{CH}	FCE# Hold Time for Command/Data Write Cycle	15	-	ns
T_{CHR}	FCE# Hold Time for Sequential Read Last Cycle	-	40	ns
T_{WP}	FWE# Pulse Width	15	-	ns
T_{WH}	FWE# High Hold Time	15	-	ns
T_{WC}	Write Cycle Time	30	-	ns
T_{ALS}	FALE Setup Time	15	-	ns
T_{ALH}	FALE Hold Time	15	-	ns
T_{DS}	FAD[15:0] Setup Time	30	-	ns
T_{DH}	FAD[15:0] Hold Time	15	-	ns
T_{RP}	FRE# Pulse Width	15	-	ns
T_{RR}	Ready to FRE# Low	20	-	ns
T_{RES}	FRE# Data Setup Time	-	20	ns
T_{RC}	Read Cycle Time	30	-	ns
T_{REH}	FRE# High Hold Time	15	-	ns
T_{RHZ}	FRE# High to Data Hi-Z	-	100	ns

Note: All AC specifications are guaranteed by design.

T0-0.0 1355

Data Sheet

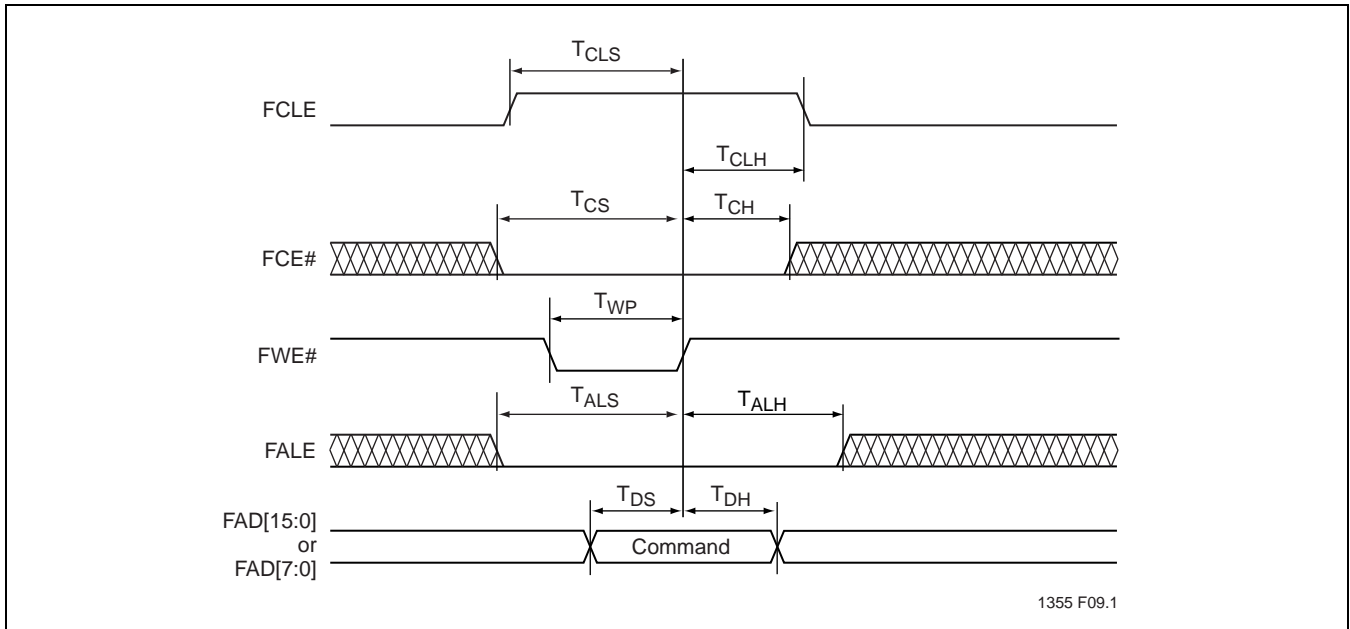

FIGURE 6: Media Command Latch Cycle

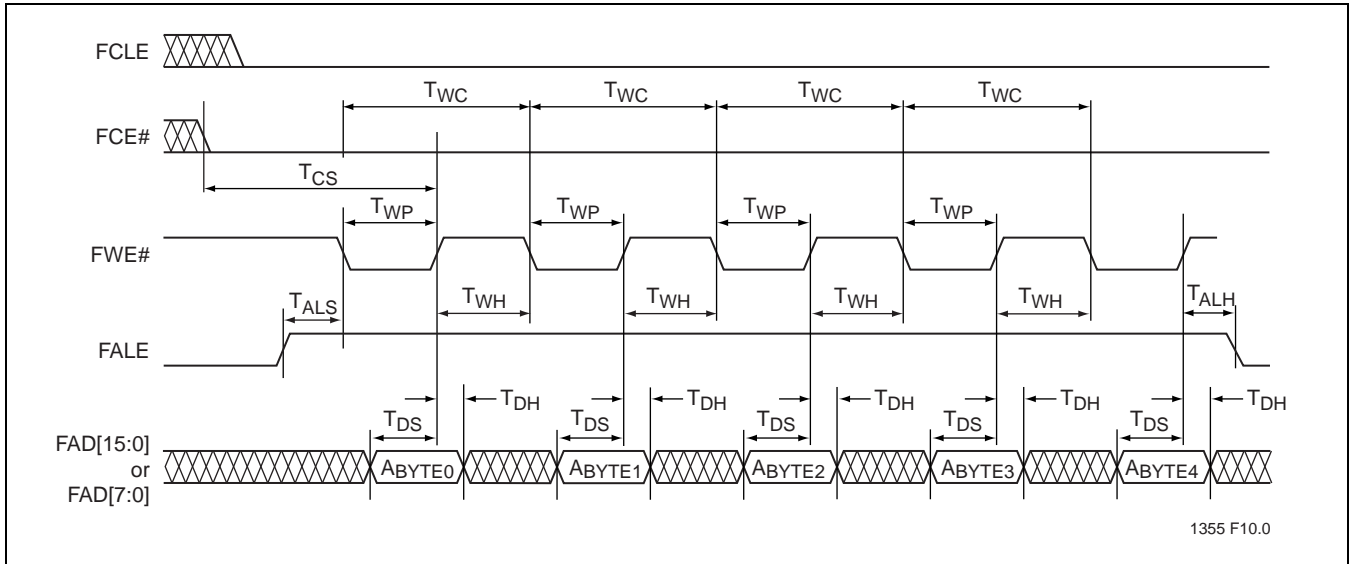

FIGURE 7: Media Address Latch Cycle

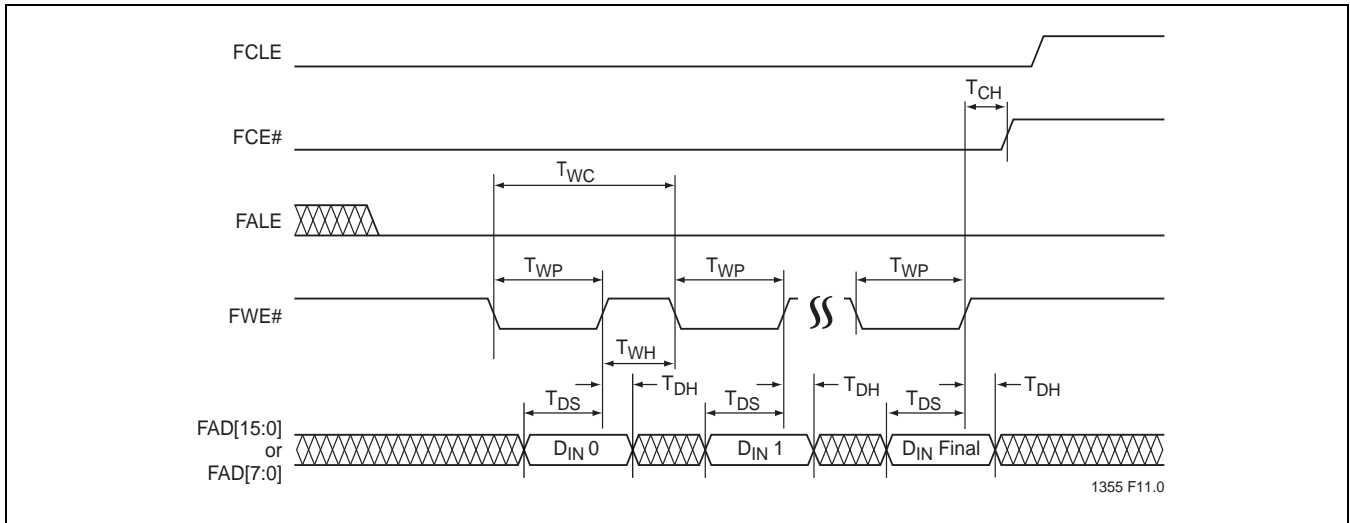

FIGURE 8: Media Data Loading Latch Cycle

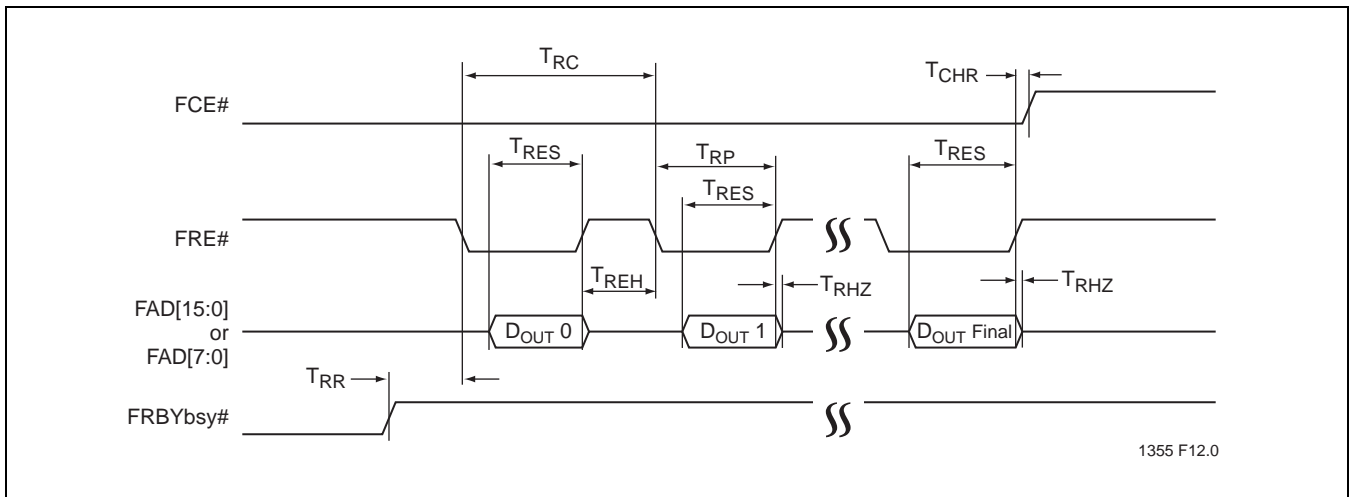
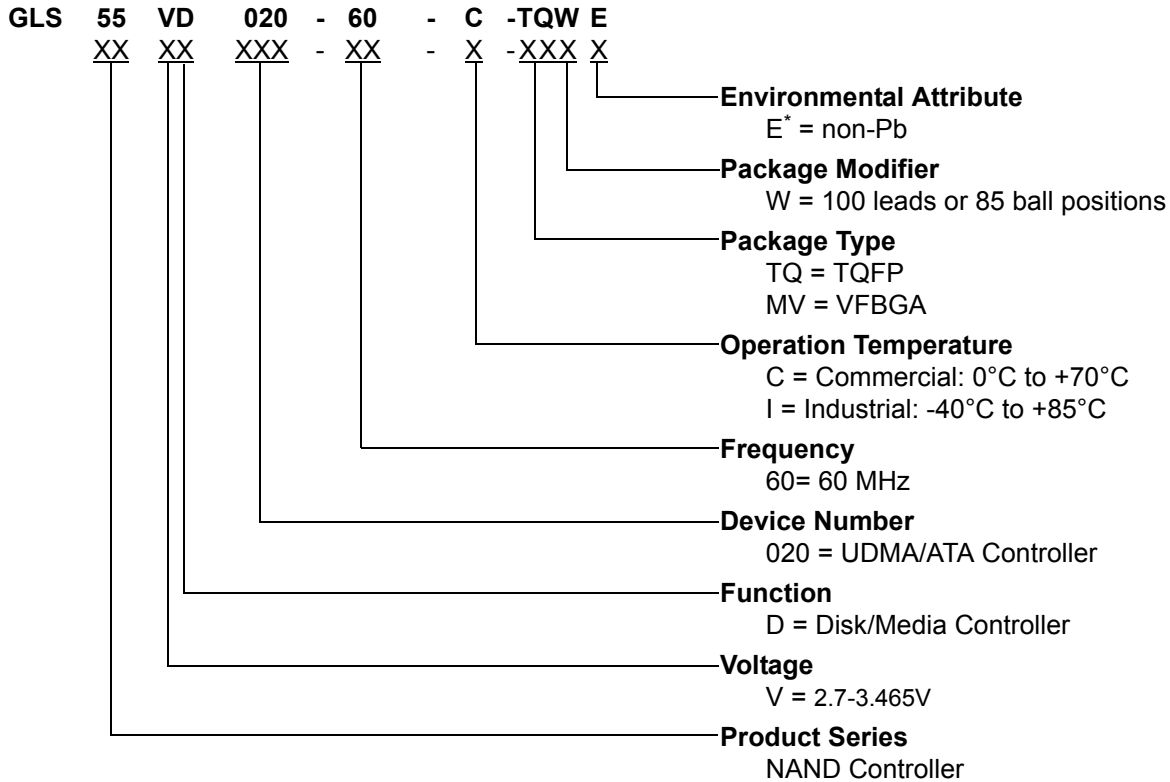

FIGURE 9: Media Data Read Cycle

Data Sheet

PRODUCT ORDERING INFORMATION

* Environmental suffix "E" denotes non-Pb solder.
 Greenliant non-Pb solder devices are "RoHS Compliant".

Valid Combinations
Valid combinations for GLS55VD020

GLS55VD020-60-C-TQWE

GLS55VD020-60-I-TQWE

Note: Valid combinations are those products in mass production or will be in mass production. Consult your Greenliant sales representative to confirm availability of valid combinations and to determine availability of new combinations.

PACKAGING DIAGRAM

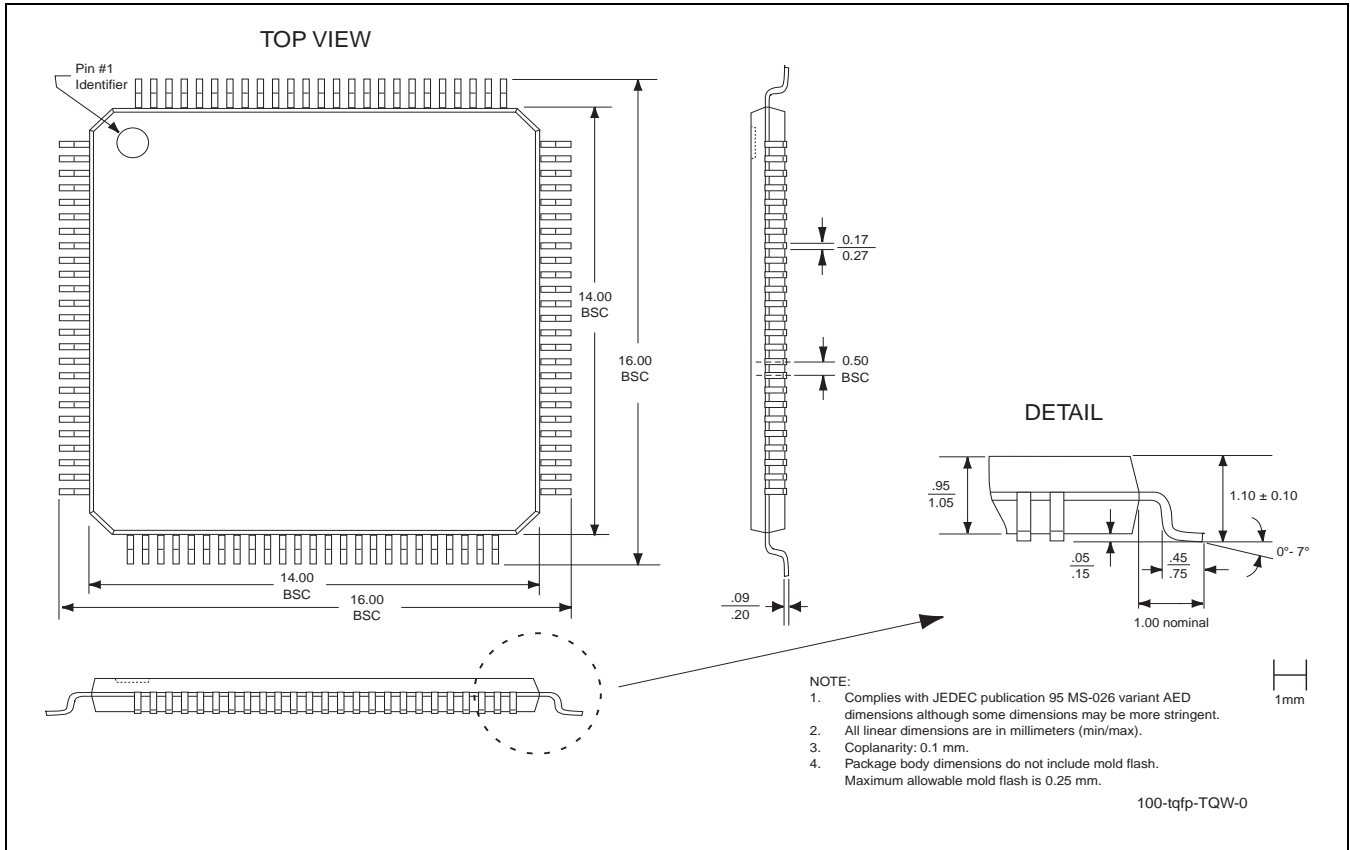
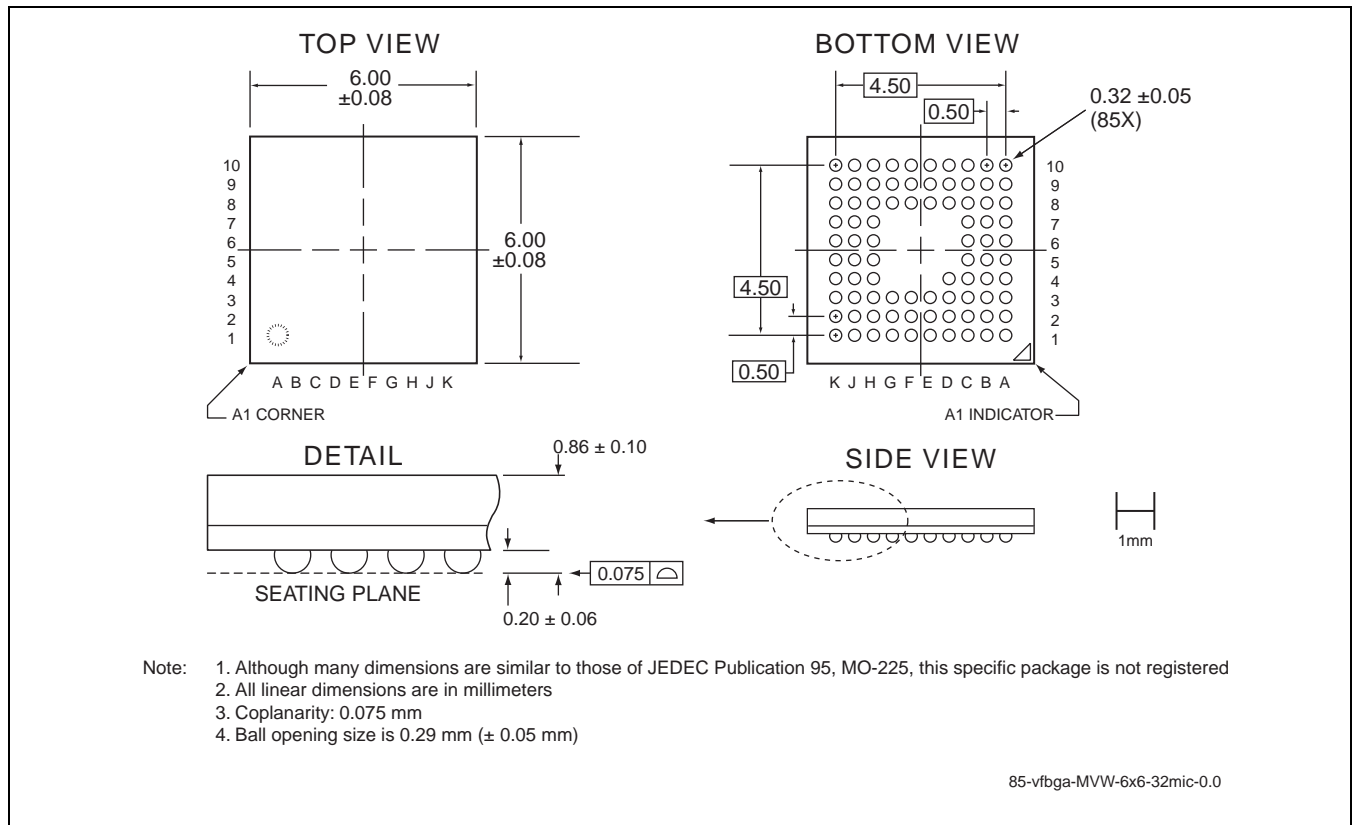

FIGURE 10: 100-lead Thin Quad Flat Pack (TQFP)
Greenliant Package Code: TQW

Data Sheet



**FIGURE 11: 85-ball Very-Thin, Fine-Pitch, Ball Grid Array (VFBGA)
Greenliant Package Code: MVW**

TABLE 22: Revision History

Number	Description	Date
00	<ul style="list-style-type: none"> Initial Release of Data Sheet 	Sep 2007
01	<ul style="list-style-type: none"> Updated “Features:” and “Product Description” Modified “General Description” on page 3. Updated Table 2 on page 11 Modified “Manufacturing Support” and “Security Features” on page 12 Removed Drive Address from Tables 5 and 6 Updated “NAND Controller Command Description” including Tables 7 and 8, and removing the entry for Word 21. Added “Word 163: CF Advanced True IDE Timing Mode Capabilities and Settings” Updated Figure 6 Updated Table 16 	Feb 2008
02	<ul style="list-style-type: none"> Globally changed product name from ATA Flash Disk to NAND Controller 	May 2009
03	<ul style="list-style-type: none"> EOL of SST55VD020-60-I-MVWE. See S71355(02) 	Jul 2009
04	<ul style="list-style-type: none"> Transferred from SST to Greenliant 	May 2010

© 2010 Greenliant Systems, Ltd. All rights reserved. Greenliant, the Greenliant logo and NANDrive are trademarks of Greenliant Systems, Ltd. All trademarks and registered trademarks are the property of their respective owners. These specifications are subject to change without notice. SuperFlash is a registered trademark of Silicon Storage Technology, Inc, a wholly owned subsidiary of Microchip Technology Inc.