



Common mode filter with ESD protection for USB 2.0 Interface

Datasheet – production data

Features

- Integrated common mode filter
- Differential pair ESD protection
- 16 V V_{BUS} ESD and EOS protection
- ID pin ESD protection
- Low profile μ QFN-8L package
- High bandwidth: >6 GHz
- Optimized for high speed USB 2.0
- High common mode attenuation at 900 MHz and 1.8 GHz
- Support of audio over USB 2.0 thanks to bidirectional ESD protection
- Ultra compact, low board space
- Low height: < 0.55 mm

Complies with the following standards:

- IEC 61000-4-2 level 4:
 - ± 15 kV (air discharge)
 - ± 8 kV (contact discharge)
- RoHS2 compliant

Applications

Where transient over-voltage protection in ESD sensitive equipment is required, such as:

- Computers
- Printers
- Communication systems
- Cellular phone handsets and accessories
- Video equipment

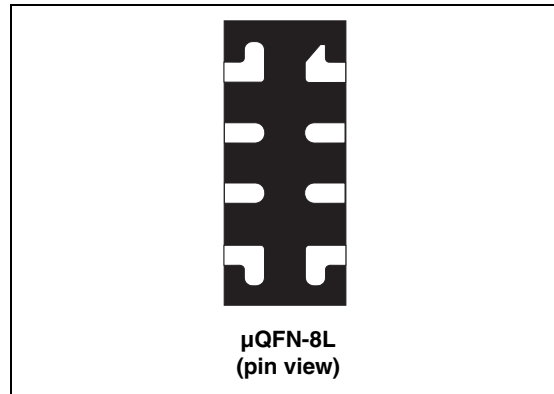
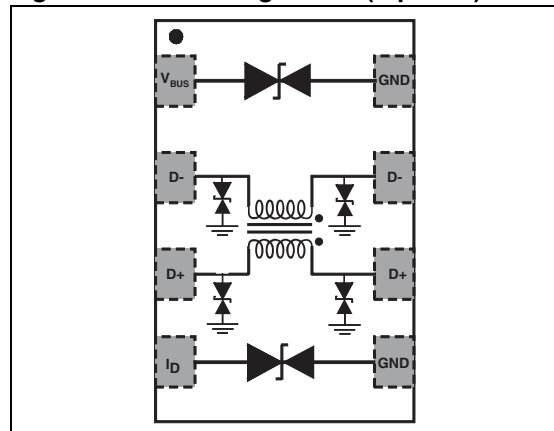


Figure 1. Pin configuration (top view)



Description

ECMF02-4CMX8 affords key component integration such as common mode filter D+ and D- lines and ESD protection on all lines. This device offers an optimized flow-through footprint for USB 2.0 applications.

1 Characteristics

Table 1. Absolute maximum ratings ($T_{amb} = 25\text{ }^{\circ}\text{C}$)

Symbol	Parameter	Value	Unit	
V_{PP}	Peak pulse voltage ⁽¹⁾	ESD discharge IEC 61000-4-2, level 4	kV	
		Contact discharge on D+/D- pins		10
		Contact discharge on V_{BUS} and I_D pins		20
		Air discharge on all pins		30
P_{PP}	Peak pulse power (8/20 μ s) on V_{BUS}	150	W	
I_{PP}	Peak pulse current (8/20 μ s) on V_{BUS}	4.8	A	
T_{op}	Operating temperature	-30 to +85	$^{\circ}\text{C}$	
T_j	Maximum junction temperature	125	$^{\circ}\text{C}$	
T_{stg}	Storage temperature range	- 55 to +150	$^{\circ}\text{C}$	

1. Measurements done on IEC 61000-4-2 test bench. For further details see Application note AN3353.

Figure 2. Electrical characteristics - definitions

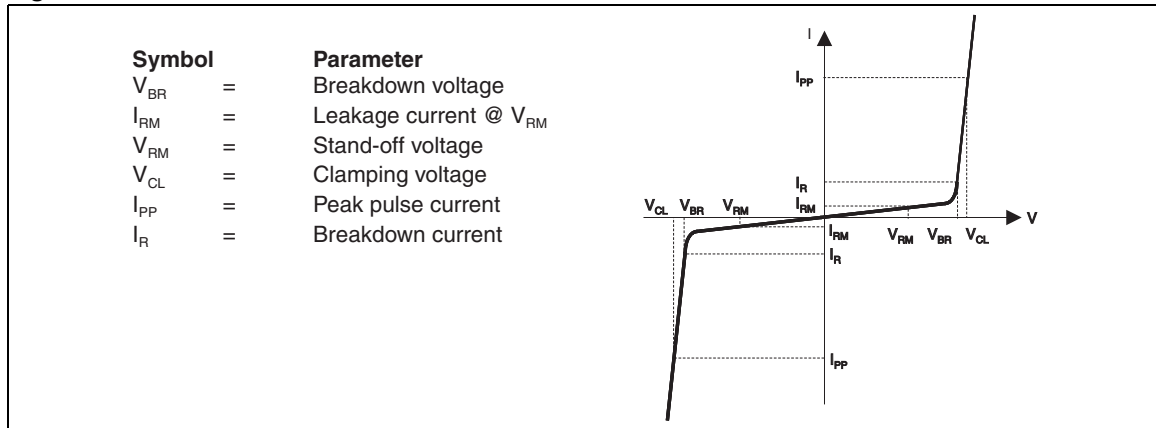


Table 2. Electrical characteristics (values, $T_{amb} = 25\text{ }^{\circ}\text{C}$)

Symbol	Test conditions	Min.	Typ.	Max.	Unit
Data Lines					
V_{BR}	$I_R = 1\text{ mA}$	6			V
I_{RM}	$V_{RM} = 5.5\text{ V per line}$			100	nA
R_{DC}	DC serial resistance on data line		3	4	Ω
V_{BUS}					
V_{BR}	$I_R = 1\text{ mA}$	15	16.5	18	V
I_{RM}	$V_{RM} = 12\text{ V}$			50	nA
V_{CL}	Clamping voltage. $I_{PP} = 1\text{ A}$, $t_p = 8/20\text{ }\mu\text{s}$			20	V
V_{CL}	Clamping voltage. $I_{PP} = 2.5\text{ A}$, $t_p = 8/20\text{ }\mu\text{s}$			24	V
I_D					
V_{BR}	$I_R = 1\text{ mA}$	6			V
I_{RM}	$V_{RM} = 1.5\text{ V per line}$			100	nA

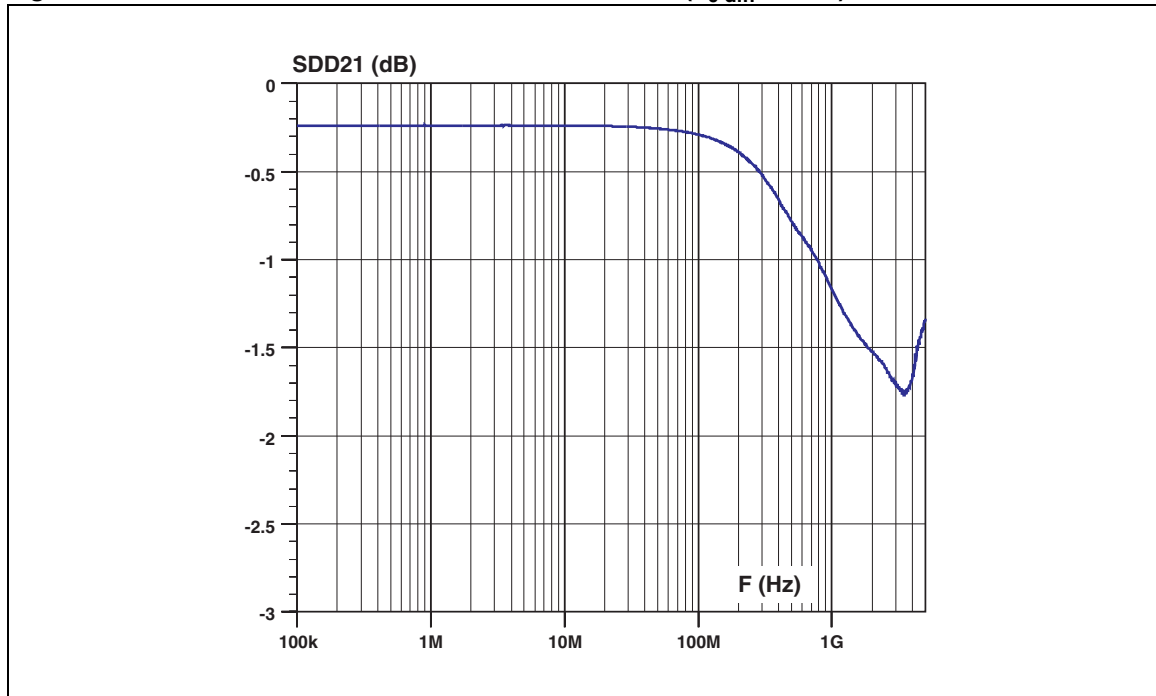
Figure 3. SDD21 differential attenuation measurement ($Z_{0\text{ diff}} = 90\text{ }\Omega$) for data lines D+ and D-

Figure 4. SCC21 common mode attenuation measurement ($Z_{0\text{ com}} = 45 \Omega$)

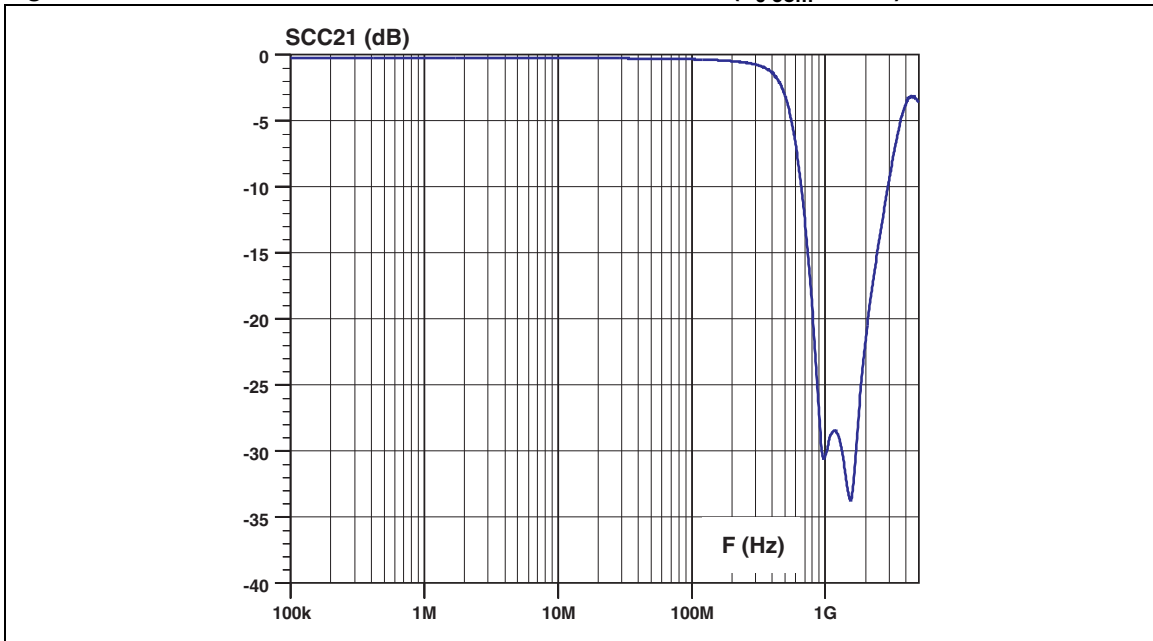


Figure 5. ID frequency response measurement ($Z_0 = 75 \Omega$)

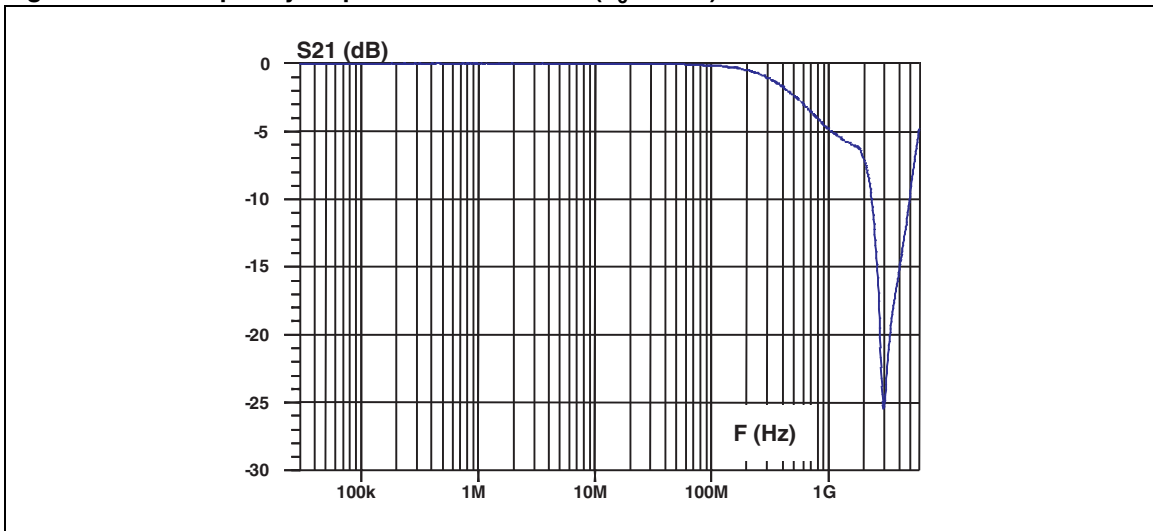


Figure 6. ESD test conditions

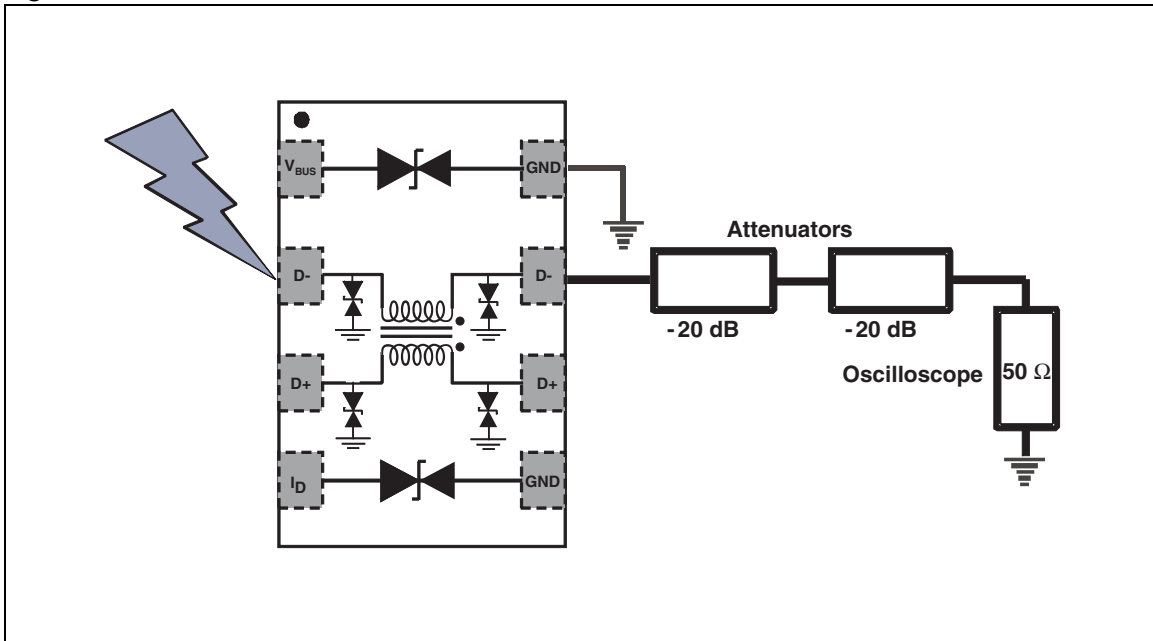


Figure 7. ESD response to IEC 61000-4-2 (+8 kV contact discharge) on V_{BUS}

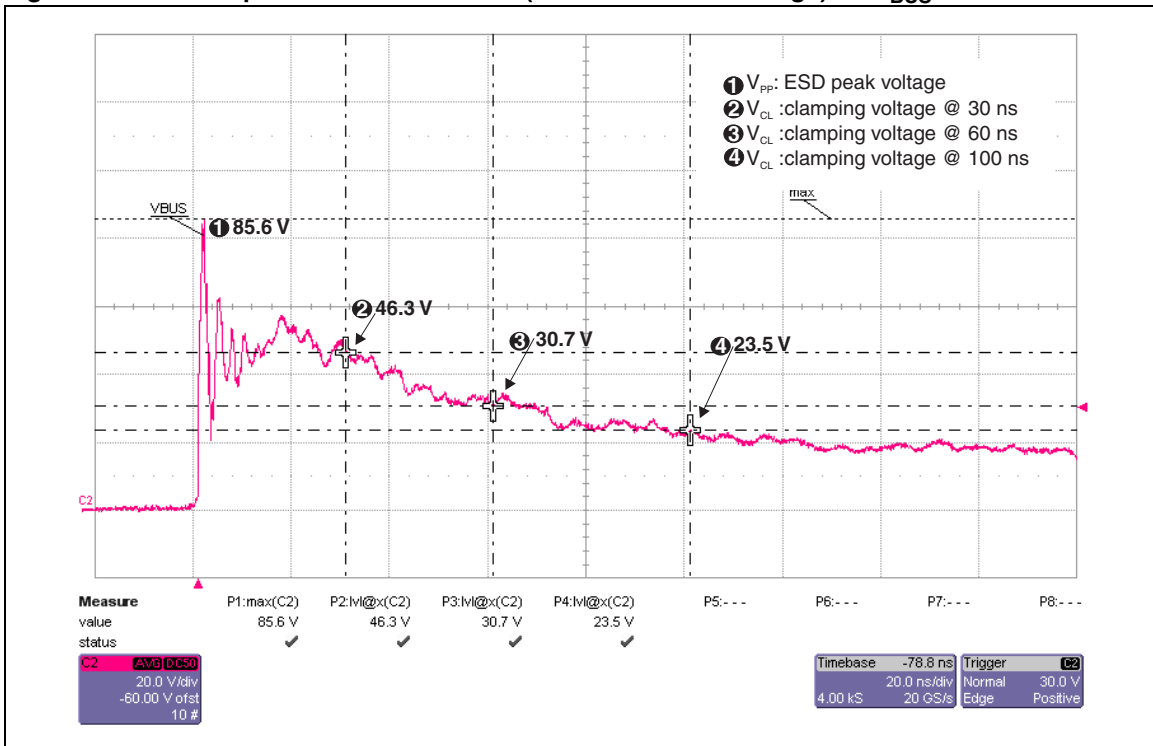


Figure 8. ESD response to IEC 61000-4-2 (-8 kV contact discharge) on V_{BUS}

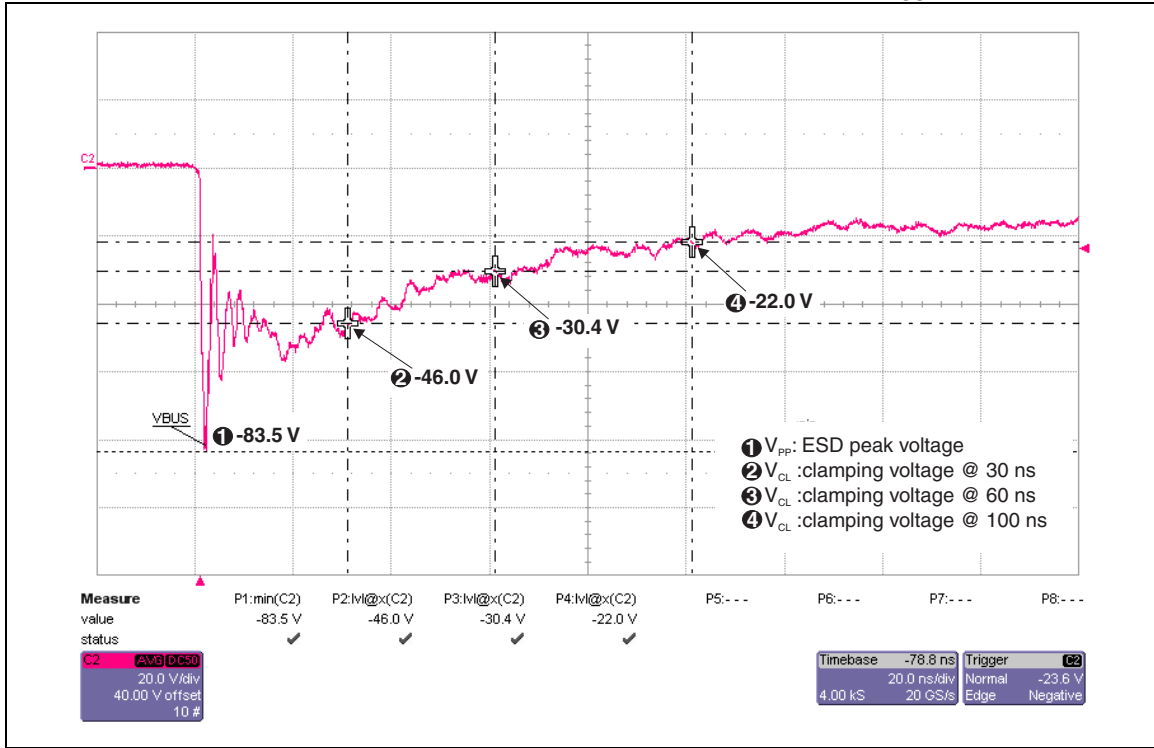


Figure 9. ESD response to IEC 61000-4-2 (+8 kV contact discharge) on I_D

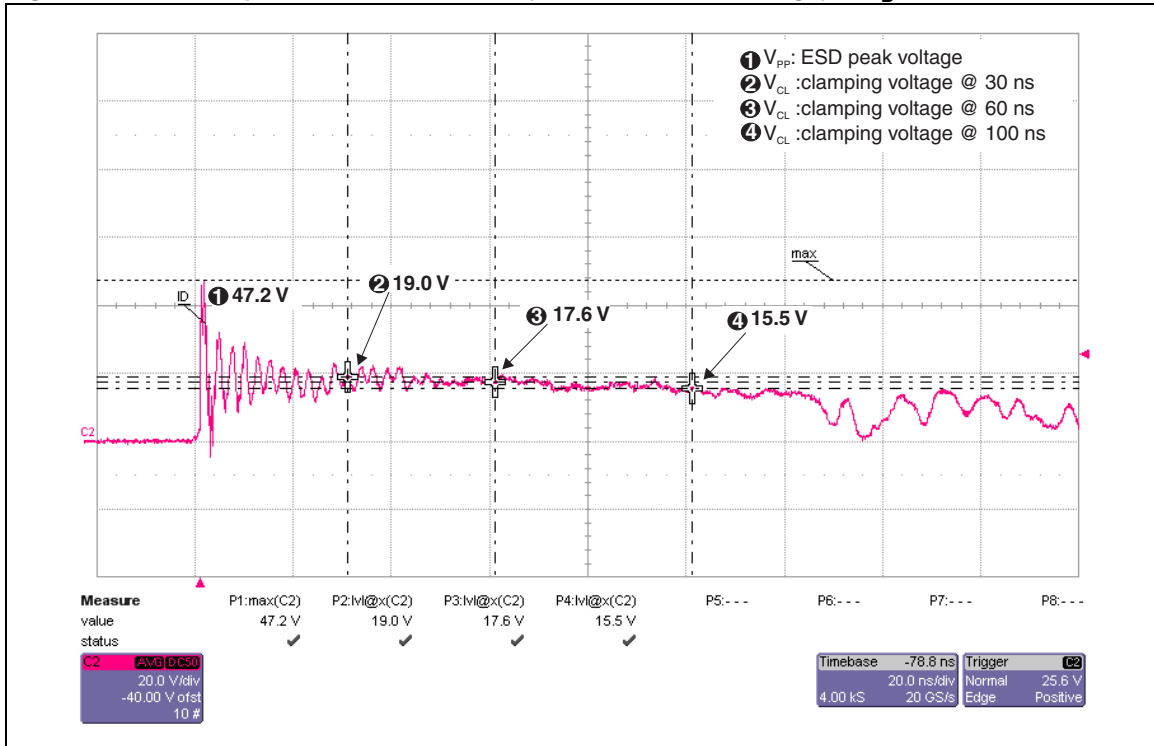


Figure 10. ESD response to IEC 61000-4-2 (-8 kV contact discharge) on I_D

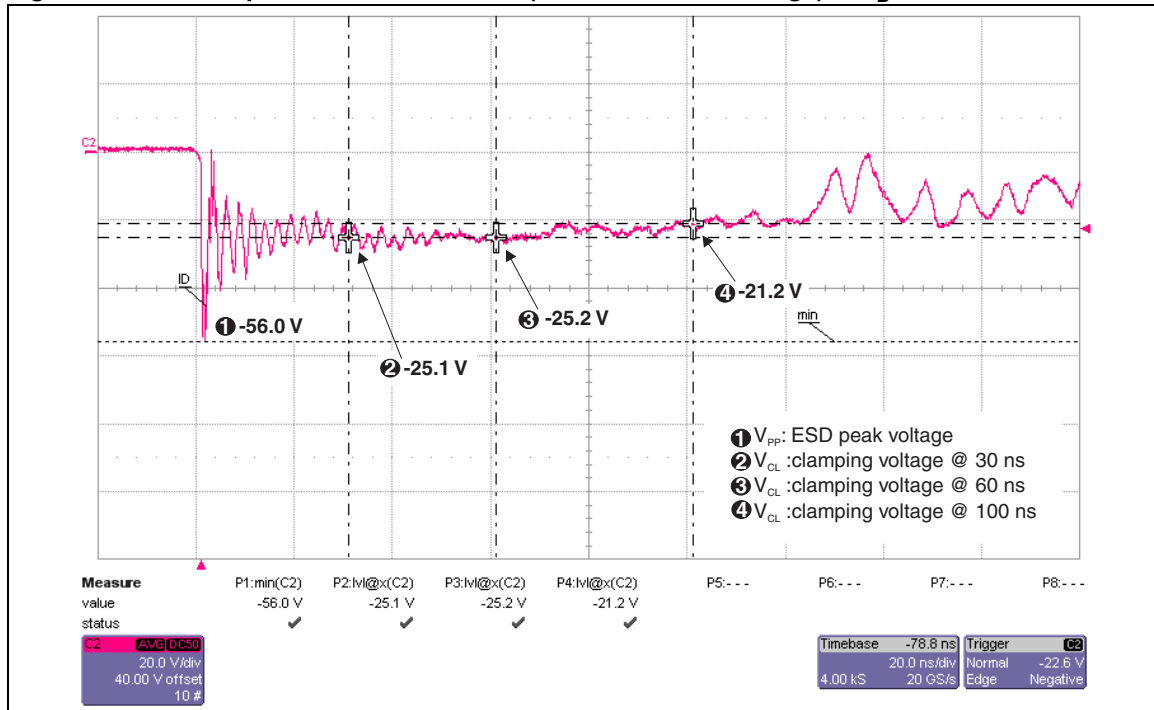


Figure 11. ESD response to IEC 61000-4-2 (+8 kV contact discharge) on differential lane

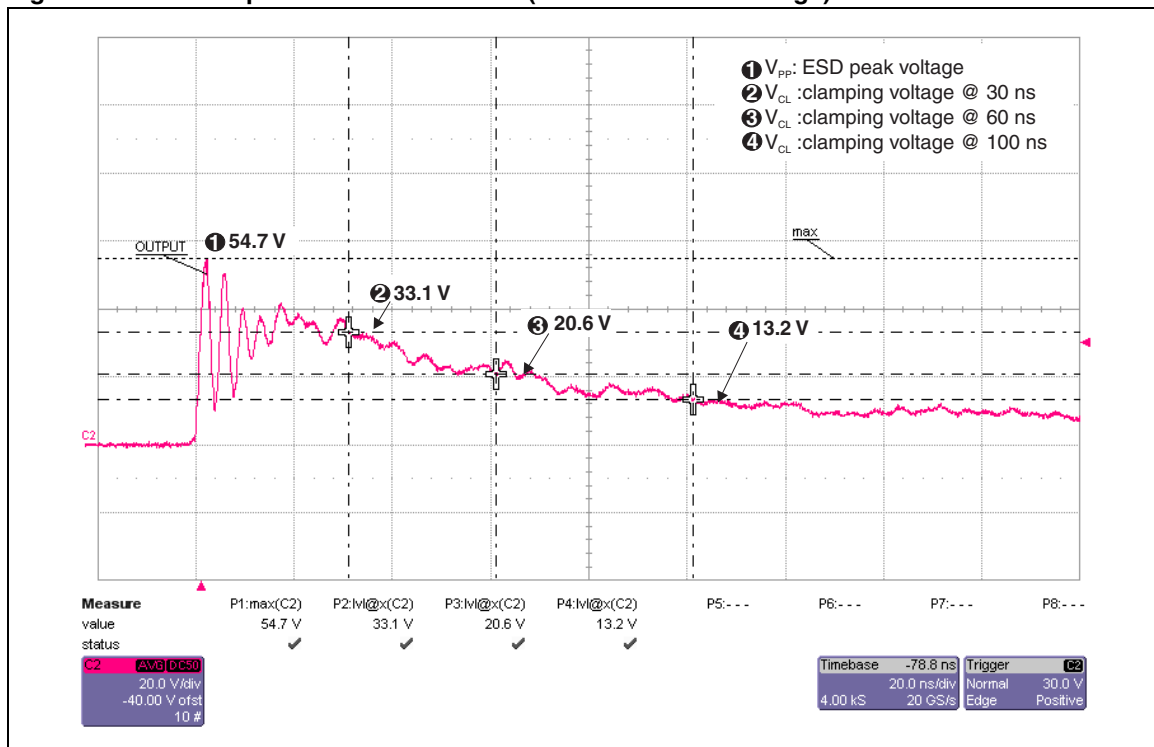


Figure 12. ESD response to IEC 61000-4-2 (-8 kV contact discharge) on differential lane

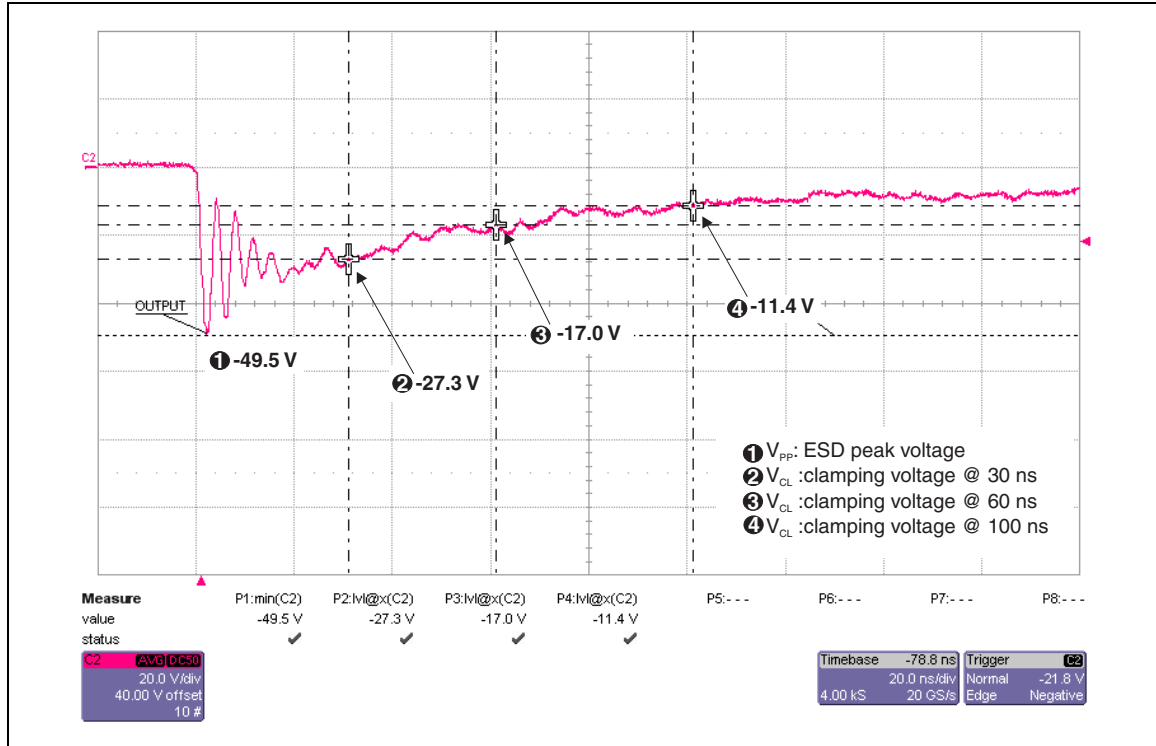


Figure 13. Eye diagram (loaded by $Z_{diff} = 90 \Omega$) with USB2.0 [mask 1] board only

Figure 14. Eye diagram (loaded by $Z_{diff} = 90 \Omega$) with USB2.0 [mask 1] board with ECM02-4CMX8

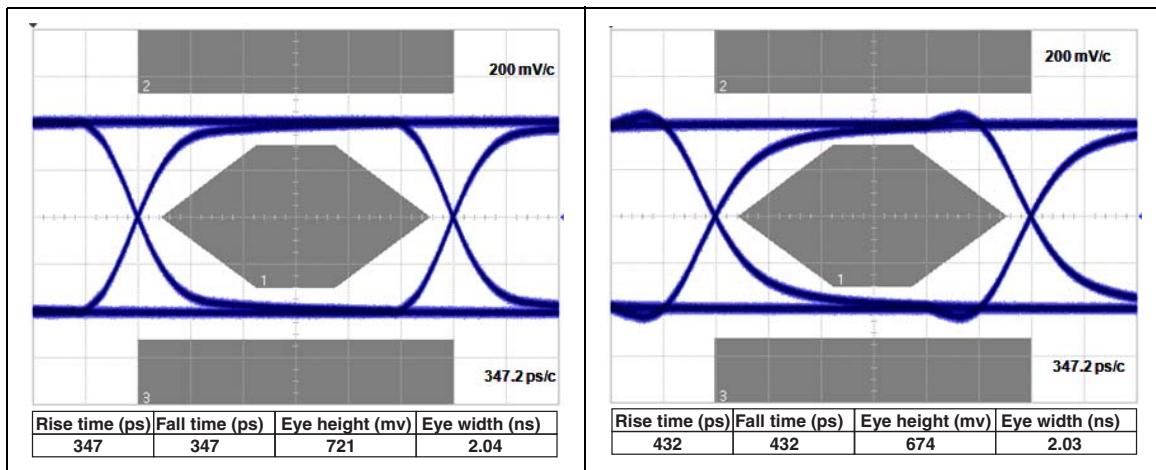


Figure 15. TDR measurement (loaded by $Z_{diff} = 90 \Omega$), rise time 400 ps

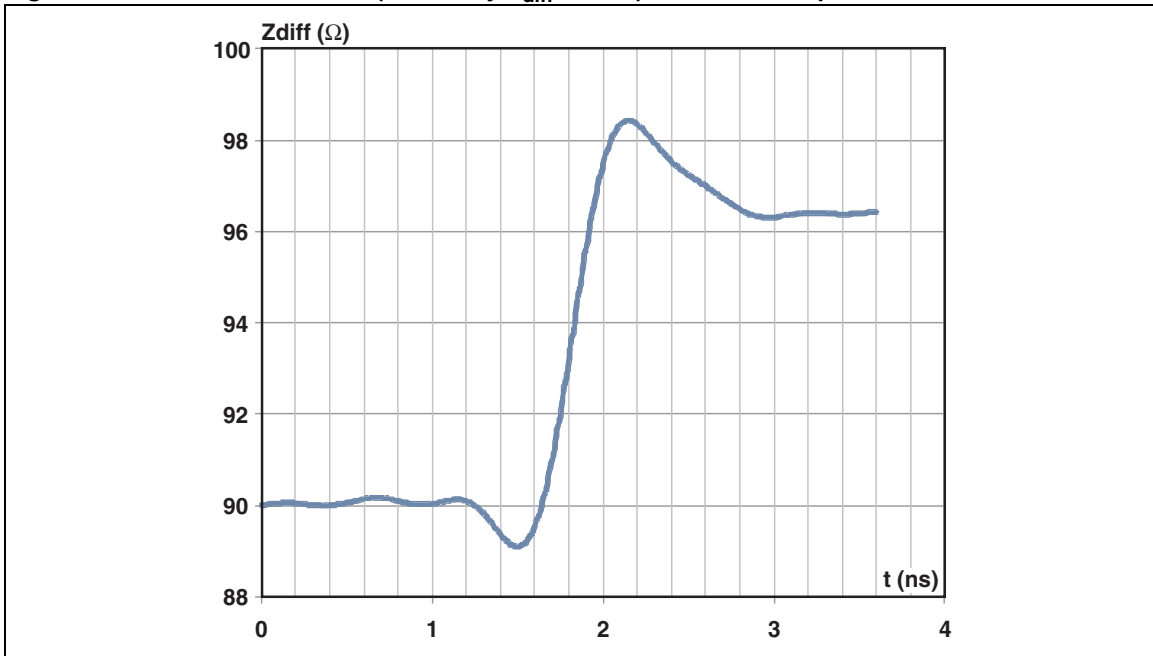


Figure 16. HS sync

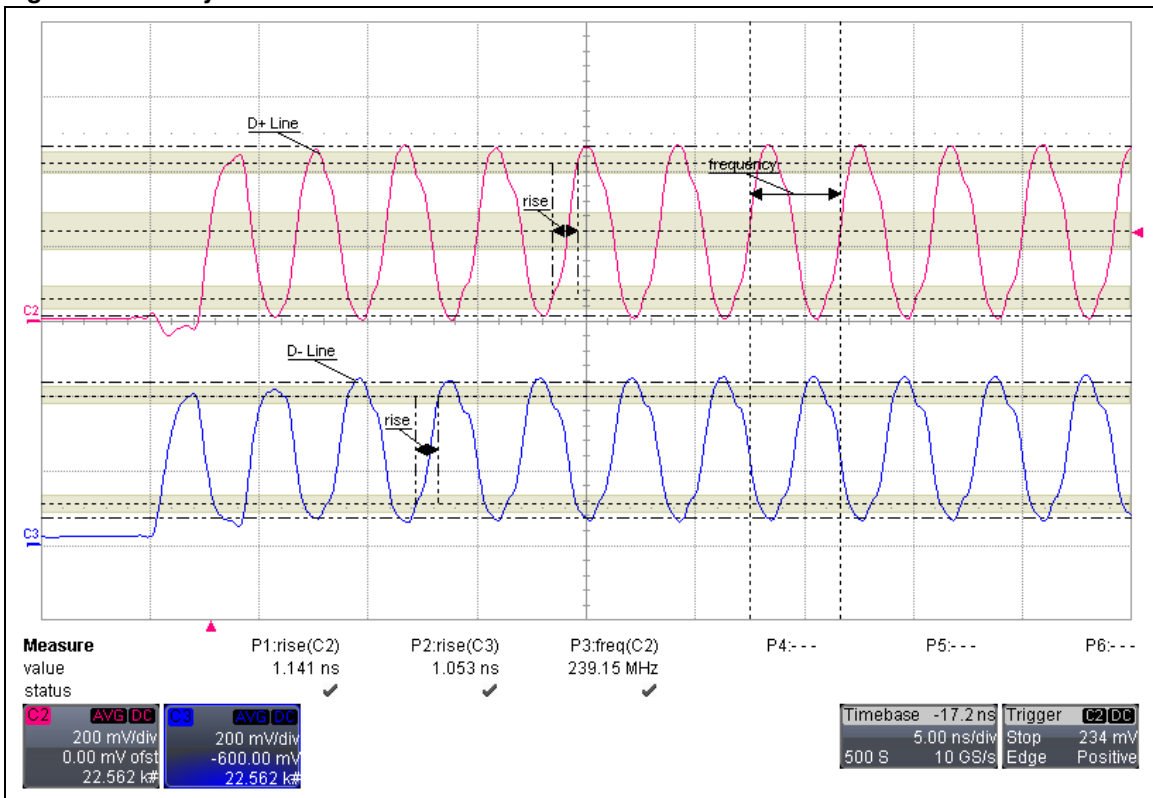


Figure 17. Total harmonic distortion on differential lanes

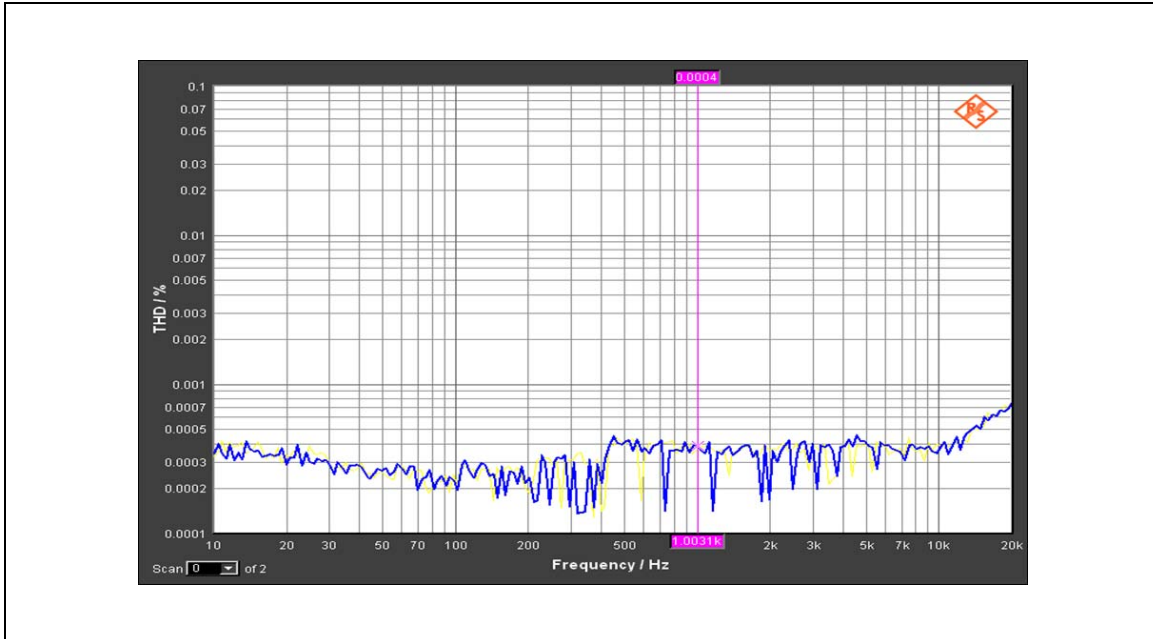
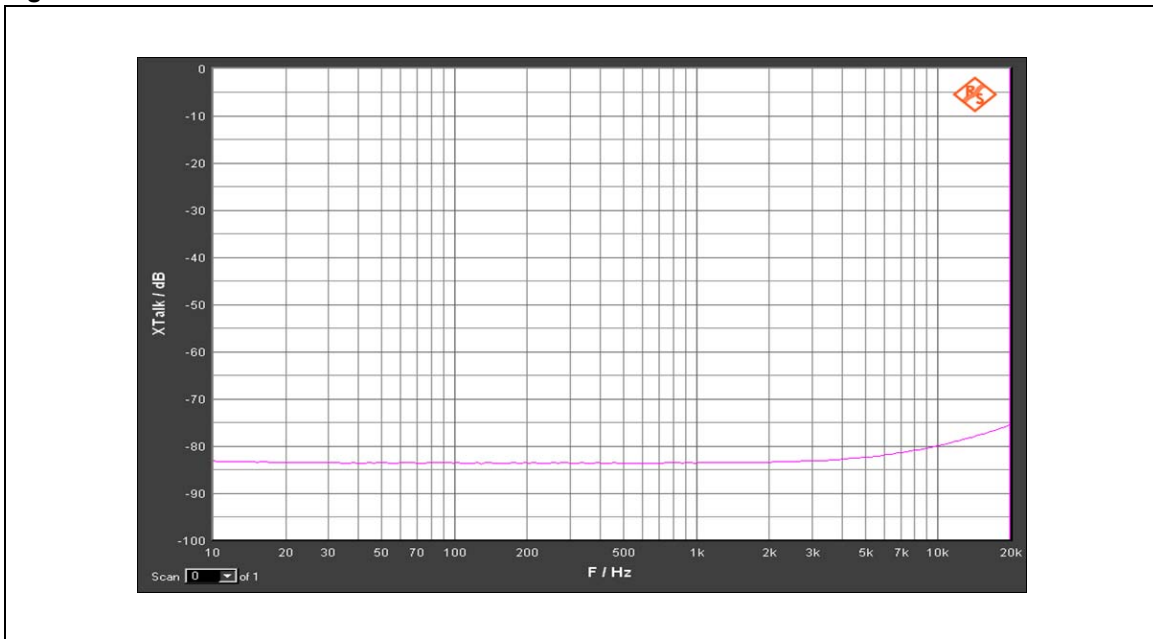
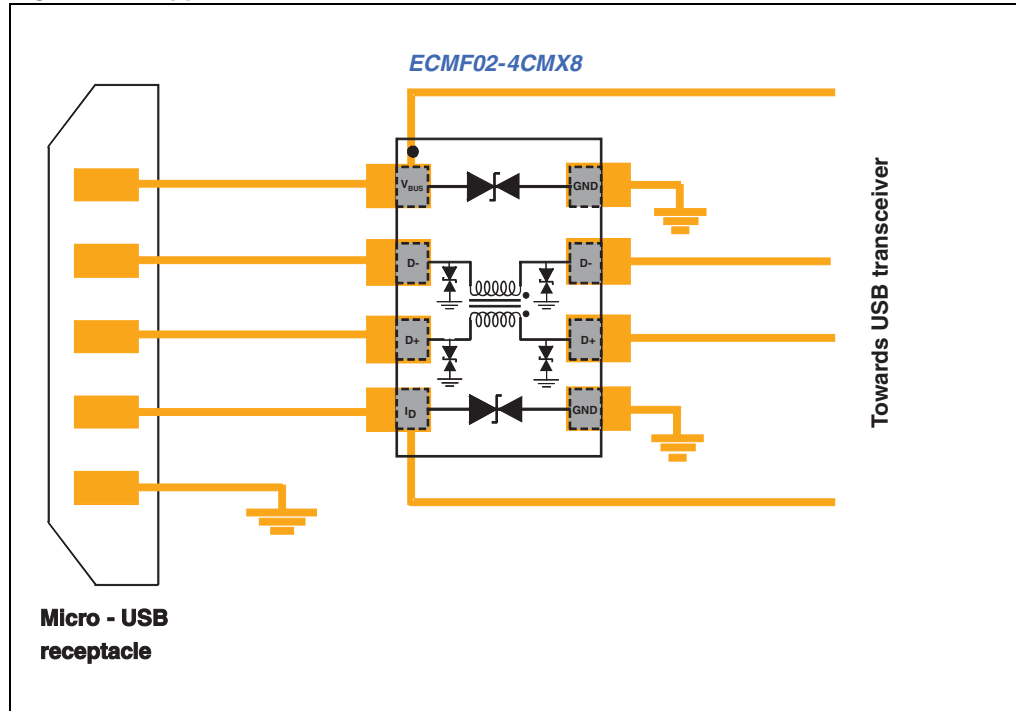


Figure 18. Crosstalk on differential lanes



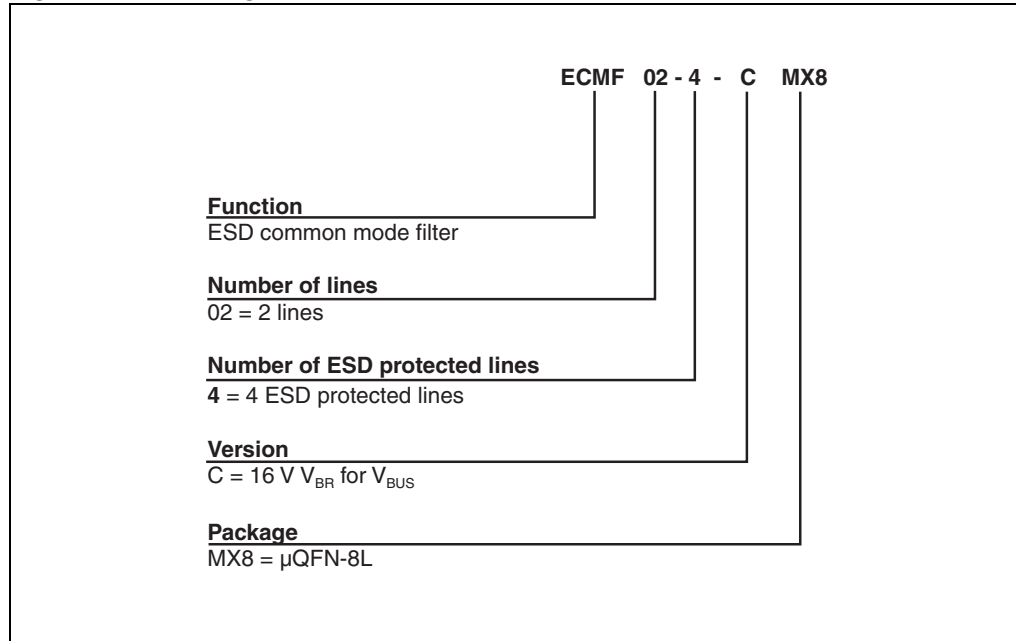
2 Application schematic

Figure 19. Application schematic



3 Ordering information scheme

Figure 20. Ordering information scheme



4 Package information

- Epoxy meets UL94, V0
- Lead-free packages

In order to meet environmental requirements, ST offers these devices in different grades of ECOPACK[®] packages, depending on their level of environmental compliance. ECOPACK[®] specifications, grade definitions and product status are available at: www.st.com. ECOPACK[®] is an ST trademark.

Figure 21. μ QFN-8L dimension definitions

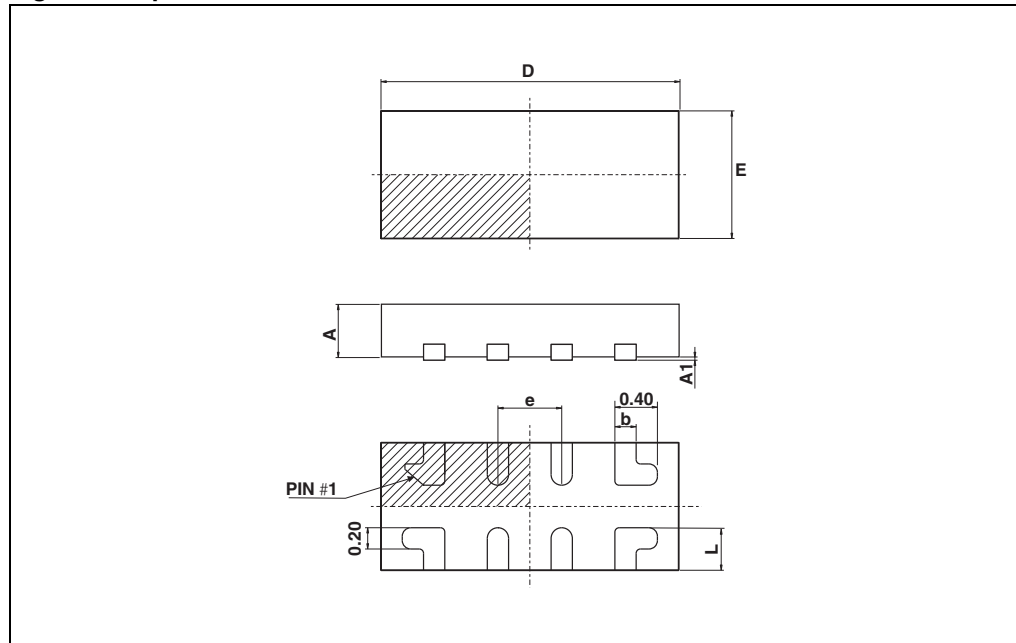


Table 3. μ QFN-8L dimension values

Ref.	Dimensions					
	Millimeters			Inches		
	Min.	Typ.	Max.	Min.	Typ.	Max.
A	0.45	0.50	0.55	0.018	0.020	0.022
A1	0.00	0.02	0.05	0.00	0.0008	0.002
b	0.15	0.20	0.25	0.006	0.008	0.010
D	2.45	2.50	2.55	0.096	0.098	0.100
E	1.15	1.20	1.25	0.045	0.047	0.049
e	0.45	0.50	0.55	0.018	0.020	0.022
L	0.30	0.40	0.50	0.012	0.016	0.020

Figure 22. Footprint

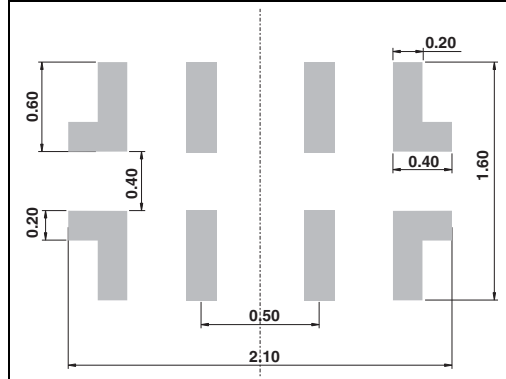


Figure 23. Marking

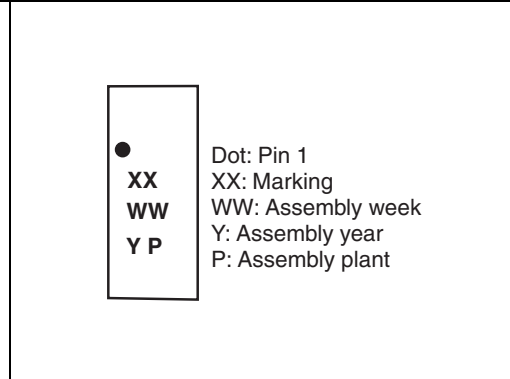
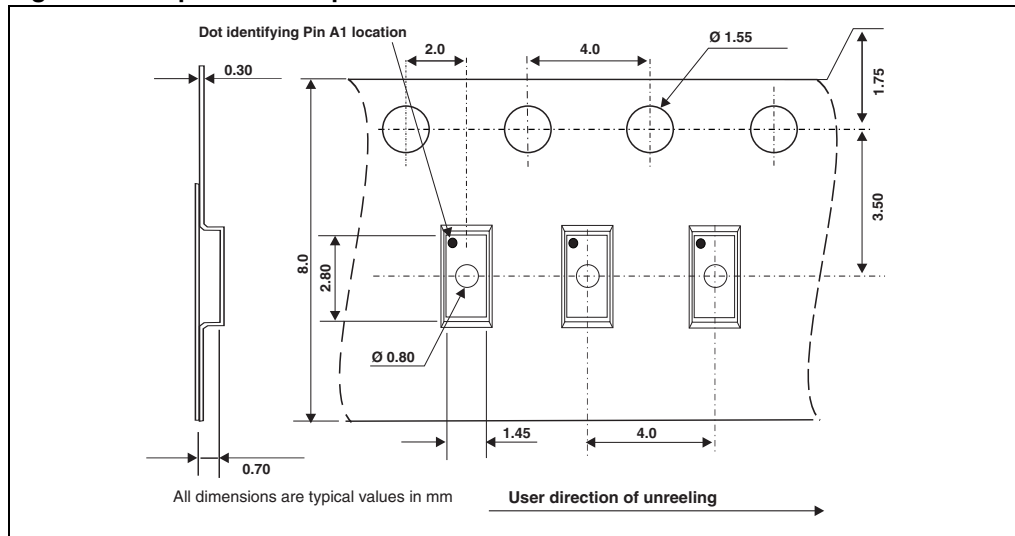


Figure 24. Tape and reel specifications



Note: More packing information is available in the application notes: AN1751: “EMI Filters: Recommendations and measurements”

5 Ordering information

Table 4. Ordering information

Order code	Marking	Package	Weight	Base qty	Delivery mode
ECMF02-4CMX8	KG	μ QFN-8L	3,7 mg	3000	Tape and reel

For the latest information on available order codes see the product pages on: www.st.com.

6 Revision history

Table 5. Document revision history

Date	Revision	Changes
19-Sep-2012	1	Initial release.

Please Read Carefully:

Information in this document is provided solely in connection with ST products. STMicroelectronics NV and its subsidiaries ("ST") reserve the right to make changes, corrections, modifications or improvements, to this document, and the products and services described herein at any time, without notice.

All ST products are sold pursuant to ST's terms and conditions of sale.

Purchasers are solely responsible for the choice, selection and use of the ST products and services described herein, and ST assumes no liability whatsoever relating to the choice, selection or use of the ST products and services described herein.

No license, express or implied, by estoppel or otherwise, to any intellectual property rights is granted under this document. If any part of this document refers to any third party products or services it shall not be deemed a license grant by ST for the use of such third party products or services, or any intellectual property contained therein or considered as a warranty covering the use in any manner whatsoever of such third party products or services or any intellectual property contained therein.

UNLESS OTHERWISE SET FORTH IN ST'S TERMS AND CONDITIONS OF SALE ST DISCLAIMS ANY EXPRESS OR IMPLIED WARRANTY WITH RESPECT TO THE USE AND/OR SALE OF ST PRODUCTS INCLUDING WITHOUT LIMITATION IMPLIED WARRANTIES OF MERCHANTABILITY, FITNESS FOR A PARTICULAR PURPOSE (AND THEIR EQUIVALENTS UNDER THE LAWS OF ANY JURISDICTION), OR INFRINGEMENT OF ANY PATENT, COPYRIGHT OR OTHER INTELLECTUAL PROPERTY RIGHT.

UNLESS EXPRESSLY APPROVED IN WRITING BY TWO AUTHORIZED ST REPRESENTATIVES, ST PRODUCTS ARE NOT RECOMMENDED, AUTHORIZED OR WARRANTED FOR USE IN MILITARY, AIR CRAFT, SPACE, LIFE SAVING, OR LIFE SUSTAINING APPLICATIONS, NOR IN PRODUCTS OR SYSTEMS WHERE FAILURE OR MALFUNCTION MAY RESULT IN PERSONAL INJURY, DEATH, OR SEVERE PROPERTY OR ENVIRONMENTAL DAMAGE. ST PRODUCTS WHICH ARE NOT SPECIFIED AS "AUTOMOTIVE GRADE" MAY ONLY BE USED IN AUTOMOTIVE APPLICATIONS AT USER'S OWN RISK.

Resale of ST products with provisions different from the statements and/or technical features set forth in this document shall immediately void any warranty granted by ST for the ST product or service described herein and shall not create or extend in any manner whatsoever, any liability of ST.

ST and the ST logo are trademarks or registered trademarks of ST in various countries.

Information in this document supersedes and replaces all information previously supplied.

The ST logo is a registered trademark of STMicroelectronics. All other names are the property of their respective owners.

© 2012 STMicroelectronics - All rights reserved

STMicroelectronics group of companies

Australia - Belgium - Brazil - Canada - China - Czech Republic - Finland - France - Germany - Hong Kong - India - Israel - Italy - Japan - Malaysia - Malta - Morocco - Philippines - Singapore - Spain - Sweden - Switzerland - United Kingdom - United States of America

www.st.com