

Features

- Low-voltage and Standard-voltage Operation
 - $V_{CC} = 1.7V$ to $5.5V$
- Internally Organized 2048 x 8 (16K)
- Two-wire Serial Interface
- Schmitt Trigger, Filtered Inputs for Noise Suppression
- Bidirectional Data Transfer Protocol
- 1MHz (5V, 2.5V), 400kHz (1.7V) Compatibility
- Write Protect Pin for Hardware Data Protection
- 16-byte Page Write Modes
- Partial Page Writes Allowed
- Self-timed Write Cycle (5ms max)
- High-reliability
 - Endurance: 1 Million Write Cycles
 - Data Retention: 100 Years
- 8-lead PDIP, 8-lead JEDEC SOIC, 8-lead TSSOP, 8-lead UDFN, 8-lead XDFN, 5-lead SOT23 and 8-ball VFBGA Packages
- Lead-free/Halogen-free
- Die Sales: Wafer Form, Tape and Reel, and Bumped Wafers

Description

The Atmel® AT24C16C provides 16,384-bits of serial electrically erasable and programmable read-only memory (EEPROM) organized as 2,048 words of 8-bits each. The device is optimized for use in many industrial and commercial applications where low-power and low-voltage operation are essential. The AT24C16C is available in space-saving 8-lead PDIP, 8-lead JEDEC SOIC, 8-lead TSSOP, 8-lead UDFN, 8-lead XDFN, 5-lead SOT23, and 8-ball VFBGA Packages and is accessed via a Two-wire serial interface. In addition, the AT24C16C operates from 1.7V to 5.5V.

Figure 0-1. Pin Configurations

Pin Name	Function
NC	No Connect
SDA	Serial Data
SCL	Serial Clock Input
WP	Write Protect
GND	Ground
VCC	Power Supply

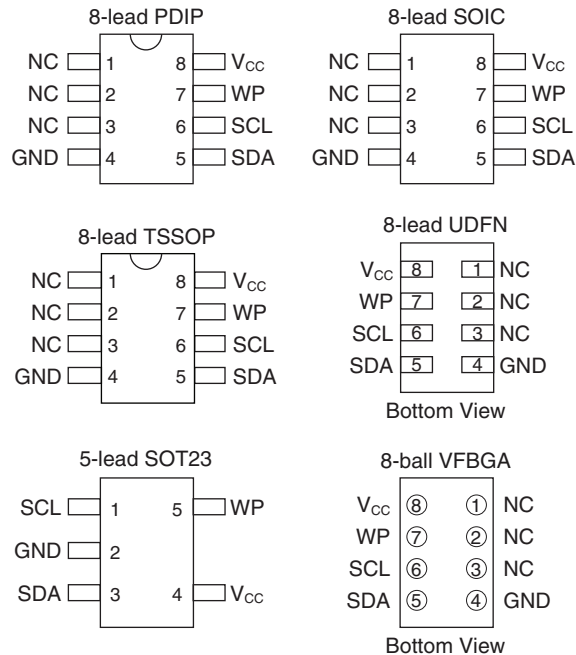

Two-wire Serial Electrically Erasable and Programmable Read-only Memory 16K (2048 x 8)

Atmel AT24C16C



Absolute Maximum Ratings

Operating Temperature.....	-55°C to +125°C
Storage Temperature	-65°C to +150°C
Voltage on Any Pin with Respect to Ground.....	-1.0V to +7.0V
Maximum Operating Voltage.....	6.25V
DC Output Current	5.0 mA

***NOTICE:** Stresses beyond those listed under “Absolute Maximum Ratings” may cause permanent damage to the device. This is a stress rating only and functional operation of the device at these or any other conditions beyond those indicated in the operational sections of this specification is not implied. Exposure to absolute maximum rating conditions for extended periods may affect device reliability.

Figure 0-2. Block Diagram

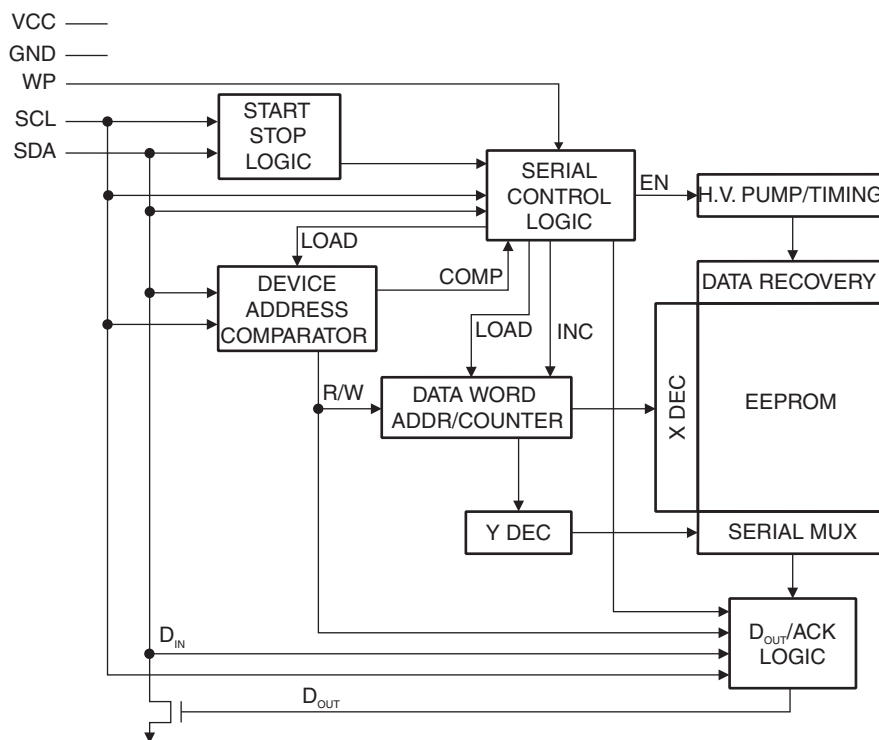

1. Pin Description

SERIAL CLOCK (SCL): The SCL input is used to positive edge clock data into each EEPROM device and negative edge clock data out of each device.

SERIAL DATA (SDA): The SDA pin is bidirectional for serial data transfer. This pin is open-drain driven and may be wire-ORed with any number of other open-drain or open-collector devices.

DEVICE/PAGE ADDRESSES: The Atmel® AT24C16C does not use the device address pins, which limits the number of devices on a single bus to one.

WRITE PROTECT (WP): The AT24C16C has a write protect pin that provides hardware data protection. The write protect pin allows normal read/write operations when connected to ground (GND). When the write protect pin is connected to V_{CC} , the write protection feature is enabled and operates as shown in [Table 1-1](#).

Table 1-1. Write Protect

WP Pin Status	Part of the Array Protected
	24C16C
At V_{CC}	Full (16K) Array
At GND	Normal Read/Write Operations

2. Memory Organization

Atmel AT24C16C, 16K SERIAL EEPROM: Internally organized with 128 pages of 16-bytes each, the 16K requires an 11-bit data word address for random word addressing.

Table 2-1. Pin Capacitance⁽¹⁾

Applicable over recommended operating range from $T_A = 25^{\circ}\text{C}$, $f = 1.0\text{MHz}$, $V_{CC} = +1.7\text{V}$

Symbol	Test Condition	Max	Units	Conditions
$C_{I/O}$	Input/Output Capacitance (SDA)	8	pF	$V_{I/O} = 0\text{V}$
C_{IN}	Input Capacitance (SCL)	6	pF	$V_{IN} = 0\text{V}$

Note: 1. This parameter is characterized and is not 100% tested

Table 2-2. DC Characteristics

Applicable over recommended operating range from: $T_{AI} = -40^{\circ}\text{C}$ to $+85^{\circ}\text{C}$, $V_{CC} = +1.7\text{V}$ to $+5.5\text{V}$
(unless otherwise noted)

Symbol	Parameter	Test Condition		Min	Typ	Max	Units
V_{CC1}	Supply Voltage			1.7		5.5	V
I_{CC1}	Supply Current	$V_{CC} = 5.0\text{V}$	READ at 400kHz		1.0	2.0	mA
I_{CC2}	Supply Current	$V_{CC} = 5.0\text{V}$	WRITE at 400kHz		2.0	3.0	mA
I_{SB1}	Standby Current	$V_{CC} = 1.7\text{V}$	$V_{IN} = V_{CC}$ or V_{SS}			1.0	μA
		$V_{CC} = 5.5\text{V}$				6.0	
I_{LI}	Input Leakage Current $V_{CC} = 5.0\text{V}$	$V_{IN} = V_{CC}$ or V_{SS}			0.10	3.0	μA
I_{LO}	Output Leakage Current $V_{CC} = 5.0\text{V}$	$V_{OUT} = V_{CC}$ or V_{SS}			0.05	3.0	μA
V_{IL}	Input Low Level ⁽¹⁾			-0.6		$V_{CC} \times 0.3$	V
V_{IH}	Input High Level ⁽¹⁾			$V_{CC} \times 0.7$		$V_{CC} + 0.5$	V
V_{OL1}	Output Low Level	$V_{CC} = 1.7\text{V}$	$I_{OL} = 0.15\text{mA}$			0.2	V
V_{OL2}	Output Low Level	$V_{CC} = 3.0\text{V}$	$I_{OL} = 2.1\text{mA}$			0.4	V

Note: 1. V_{IL} min and V_{IH} max are reference only and are not tested

Table 2-3. AC Characteristics (Industrial Temperature)

Applicable over recommended operating range from $T_{AI} = -40^{\circ}\text{C}$ to $+85^{\circ}\text{C}$, $V_{CC} = +1.7\text{V}$ to $+5.5\text{V}$, $CL = 100\text{ pF}$ (unless otherwise noted). Test conditions are listed in Note 2.

Symbol	Parameter	1.7V		2.5V, 5.0V		Units
		Min	Max	Min	Max	
f_{SCL}	Clock Frequency, SCL		400		1000	kHz
t_{LOW}	Clock Pulse Width Low	1.3		0.4		μs
t_{HIGH}	Clock Pulse Width High	0.6		0.4		μs
t_I	Noise Suppression Time ⁽¹⁾		50		50	ns
t_{AA}	Clock Low to Data Out Valid	0.05	0.9	0.05	0.55	μs
t_{BUF}	Time the bus must be free before a new transmission can start ⁽¹⁾	1.3		0.5		μs
$t_{HD,STA}$	Start Hold Time	0.6		0.25		μs
$t_{SU,STA}$	Start Set-up Time	0.6		0.25		μs
$t_{HD,DAT}$	Data In Hold Time	0		0		μs
$t_{SU,DAT}$	Data In Set-up Time	100		100		ns
t_R	Inputs Rise Time ⁽¹⁾		0.3		0.3	μs
t_F	Inputs Fall Time ⁽¹⁾		300		100	ns
$t_{SU,STO}$	Stop Set-up Time	0.6		0.25		μs
t_{DH}	Data Out Hold Time	50		50		ns
t_{WR}	Write Cycle Time		5		5	ms
Endurance ⁽¹⁾	25°C, Page Mode, 3.3V	1,000,000				Write Cycles

- Notes: 1. This parameter is characterized and is not 100% tested
2. AC measurement conditions:
 R_L (connects to V_{CC}): 1.3 k Ω (2.5V, 5.0V), 10 k Ω (1.7V)
 Input pulse voltages: 0.3 V_{CC} to 0.7 V_{CC}
 Input rise and fall times: $\leq 50\text{ns}$
 Input and output timing reference voltages: 0.5 V_{CC}

3. Device Operation

CLOCK and DATA TRANSITIONS: The SDA pin is normally pulled high with an external device. Data on the SDA pin may change only during SCL low time periods (see [Figure 3-4](#) on page 7). Data changes during SCL high periods will indicate a start or stop condition as defined below.

START CONDITION: A high-to-low transition of SDA with SCL high is a start condition which must precede any other command (see [Figure 3-5](#) on page 8).

STOP CONDITION: A low-to-high transition of SDA with SCL high is a stop condition. After a read sequence, the stop command will place the EEPROM in a standby power mode (see [Figure 3-5](#) on page 8).

ACKNOWLEDGE: All addresses and data words are serially transmitted to and from the EEPROM in 8-bit words. The EEPROM sends a zero to acknowledge that it has received each word. This happens during the ninth clock cycle.

STANDBY MODE: The Atmel® AT24C16C features a low-power standby mode which is enabled: (a) upon power-up and (b) after the receipt of the STOP bit and the completion of any internal operations.

2-WIRE SOFTWARE RESET: After an interruption in protocol, power loss or system reset, any 2-wire part can be protocol reset by following these steps:

1. Create a start bit condition
2. Clock nine cycles
3. Create another start bit followed by stop bit condition as shown below

Figure 3-1. Software Reset

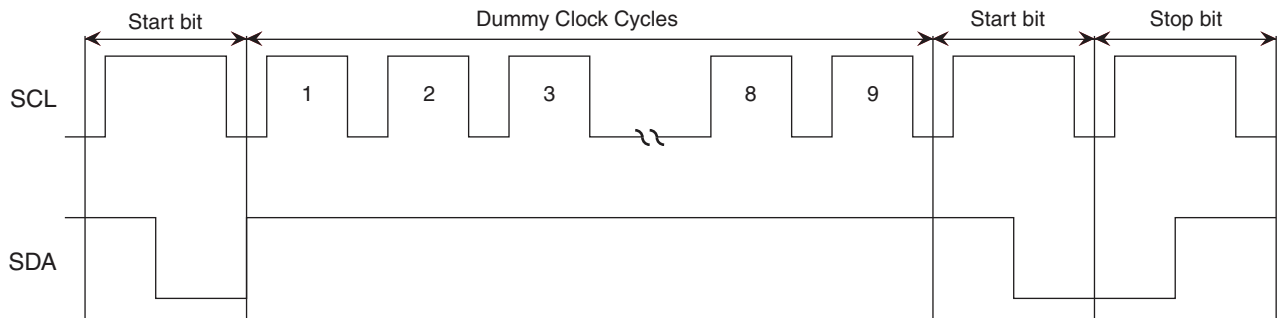

Figure 3-2. Bus Timing
SCL: Serial Clock, SDA: Serial Data I/O®

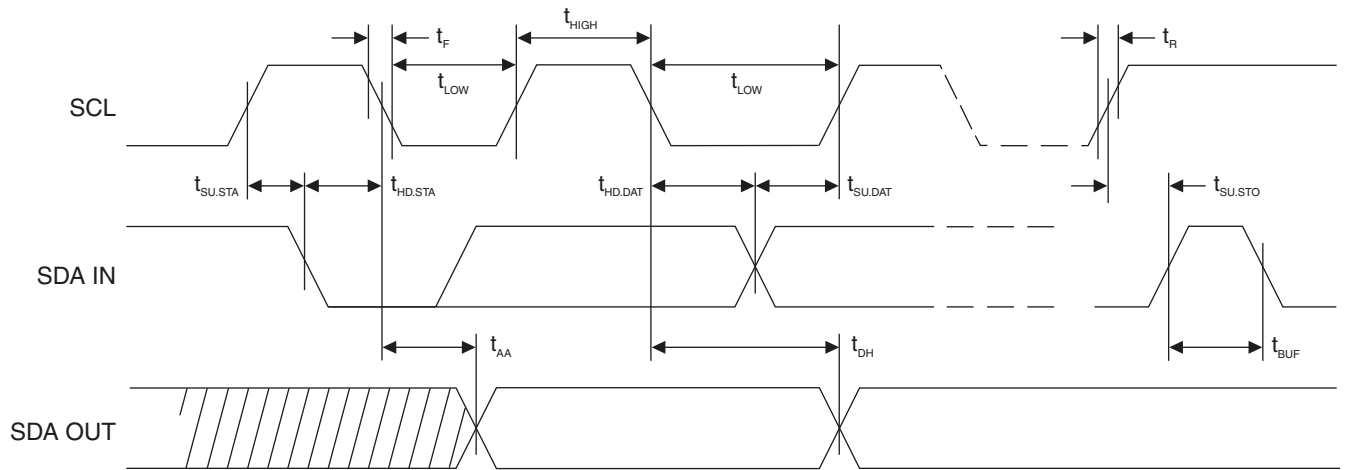
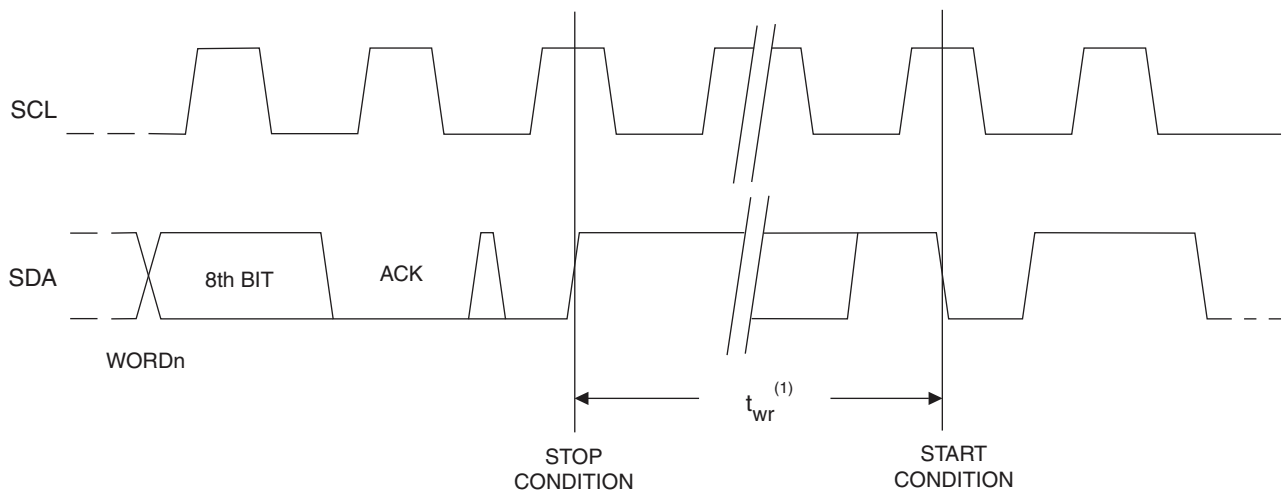

Figure 3-3. Write Cycle Timing
SCL: Serial Clock, SDA: Serial Data I/O



Note: The write cycle time t_{wr} is the time from a valid stop condition of a write sequence to the end of the internal clear/write cycle

Figure 3-4. Data Validity

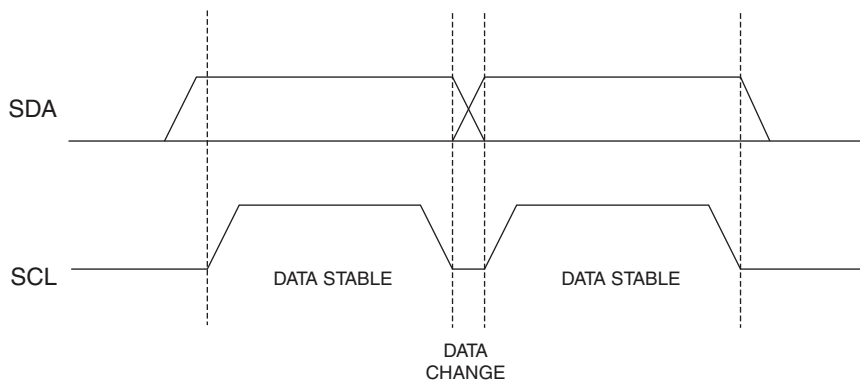

Figure 3-5. Start and Stop Definition

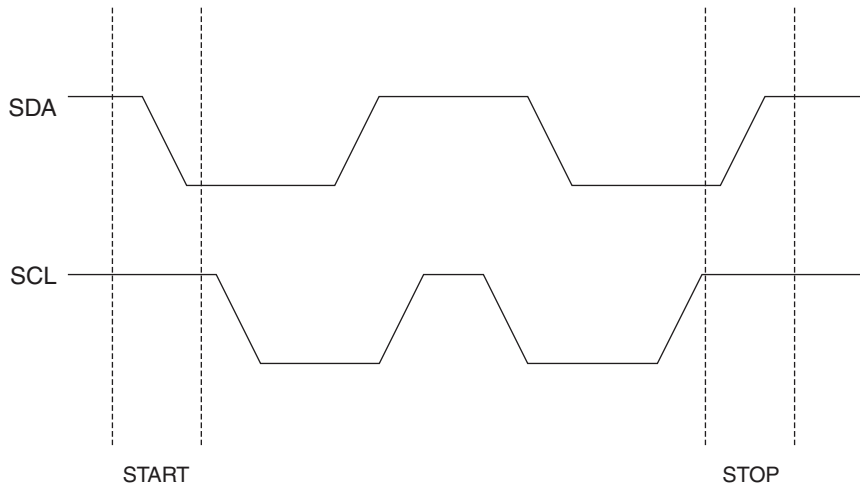
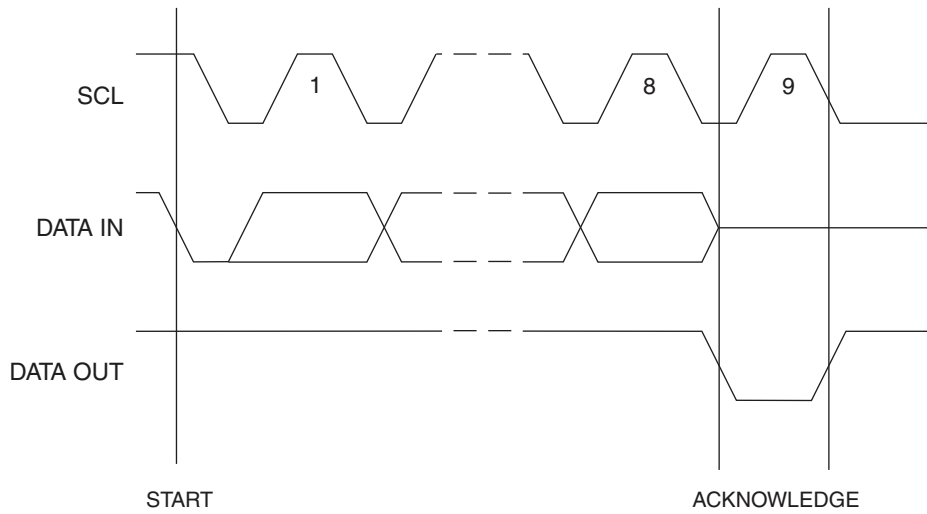

Figure 3-6. Output Acknowledge



4. Device Addressing

The 16K EEPROM device requires an 8-bit device address word following a start condition to enable the chip for a read or write operation (refer to [Figure 6-1](#)).

The device address word consists of a mandatory one, zero sequence for the first four most significant bits as shown. This is common to all the EEPROM devices.

The next three bits used for memory page addressing and are the most significant bits of the data word address which follows.

The eighth bit of the device address is the read/write operation select bit. A read operation is initiated if this bit is high and a write operation is initiated if this bit is low.

Upon a compare of the device address, the EEPROM will output a zero. If a compare is not made, the chip will return to a standby state.

5. Write Operations

BYTE WRITE: A write operation requires an 8-bit data word address following the device address word and acknowledgment. Upon receipt of this address, the EEPROM will again respond with a zero and then clock in the first 8-bit data word. Following receipt of the 8-bit data word, the EEPROM will output a zero and the addressing device, such as a microcontroller, must terminate the write sequence with a stop condition. At this time the EEPROM enters an internally timed write cycle, t_{WR} , to the nonvolatile memory. All inputs are disabled during this write cycle and the EEPROM will not respond until the write is complete (see [Figure 6-2](#) on page 10).

PAGE WRITE: The 16K EEPROM is capable of an 16-byte page write.

A page write is initiated the same as a byte write, but the microcontroller does not send a stop condition after the first data word is clocked in. Instead, after the EEPROM acknowledges receipt of the first data word, the microcontroller can transmit up to fifteen data words. The EEPROM will respond with a zero after each data word received. The microcontroller must terminate the page write sequence with a stop condition (see [Figure 6-3](#) on page 11).

The data word address lower four bits are internally incremented following the receipt of each data word. The higher data word address bits are not incremented, retaining the memory page row location. When the word address, internally generated, reaches the page boundary, the following byte is placed at the beginning of the same page. If more than sixteen data words are transmitted to the EEPROM, the data word address will “roll over” and previous data will be overwritten.

ACKNOWLEDGE POLLING: Once the internally timed write cycle has started and the EEPROM inputs are disabled, acknowledge polling can be initiated. This involves sending a start condition followed by the device address word. The read/write bit is representative of the operation desired. Only if the internal write cycle has completed will the EEPROM respond with a zero allowing the read or write sequence to continue.

6. Read Operations

Read operations are initiated the same way as write operations with the exception that the read/write select bit in the device address word is set to one. There are three read operations: current address read, random address read and sequential read.

CURRENT ADDRESS READ: The internal data word address counter maintains the last address accessed during the last read or write operation, incremented by one. This address stays valid between operations as long as the chip power is maintained. The address “roll over” during read is from the last byte of the last memory page to the first byte of the first page. The address “roll over” during write is from the last byte of the current page to the first byte of the same page.

Once the device address with the read/write select bit set to one is clocked in and acknowledged by the EEPROM, the current address data word is serially clocked out. The microcontroller does not respond with an input zero but does generate a following stop condition (see [Figure 6-4](#) on page 11).

RANDOM READ: A random read requires a “dummy” byte write sequence to load in the data word address. Once the device address word and data word address are clocked in and acknowledged by the EEPROM, the microcontroller must generate another start condition. The microcontroller now initiates a current address read by sending a device address with the read/write select bit high. The EEPROM acknowledges the device address and serially clocks out the data word. The microcontroller does not respond with a zero but does generate a following stop condition (see [Figure 6-5](#) on page 11).

SEQUENTIAL READ: Sequential reads are initiated by either a current address read or a random address read. After the microcontroller receives a data word, it responds with an acknowledge. As long as the EEPROM receives an acknowledge, it will continue to increment the data word address and serially clock out sequential data words. When the memory address limit is reached, the data word address will “roll over” and the sequential read will continue. The sequential read operation is terminated when the microcontroller does not respond with a zero but does generate a following stop condition (see [Figure 6-6](#) on page 11).

Figure 6-1. Device Address

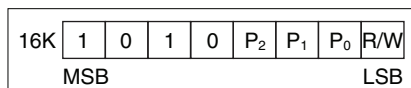

Figure 6-2. Byte Write

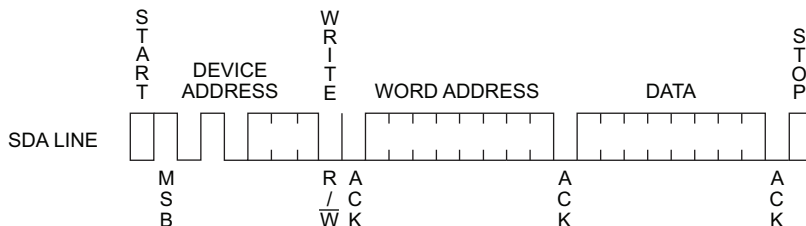

Figure 6-3. Page Write

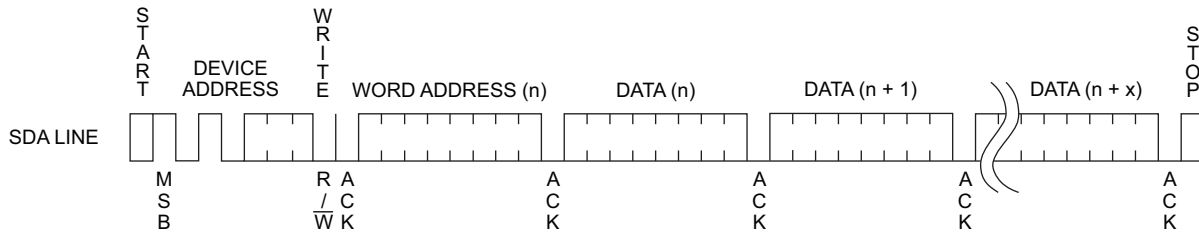

Figure 6-4. Current Address Read

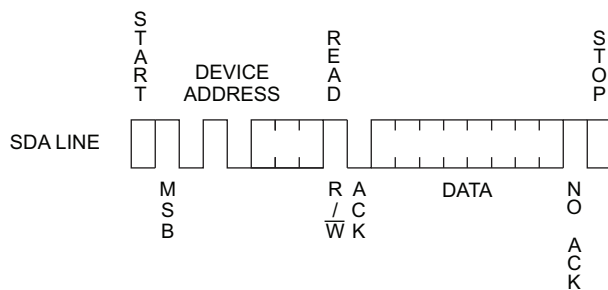

Figure 6-5. Random Read

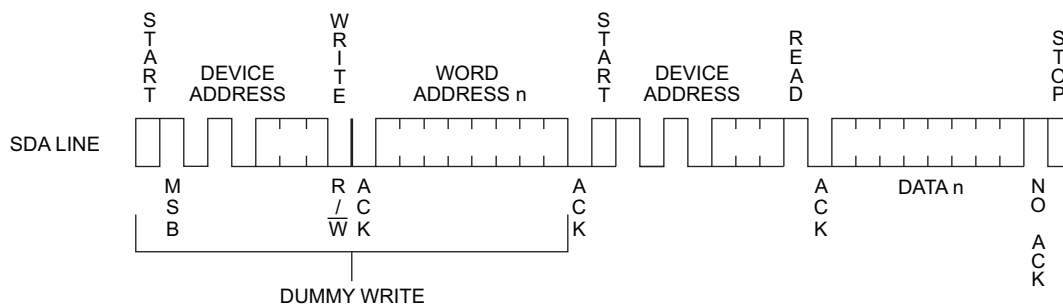
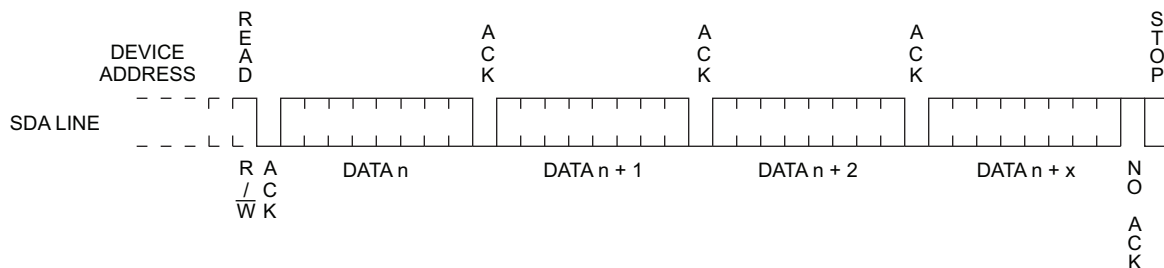
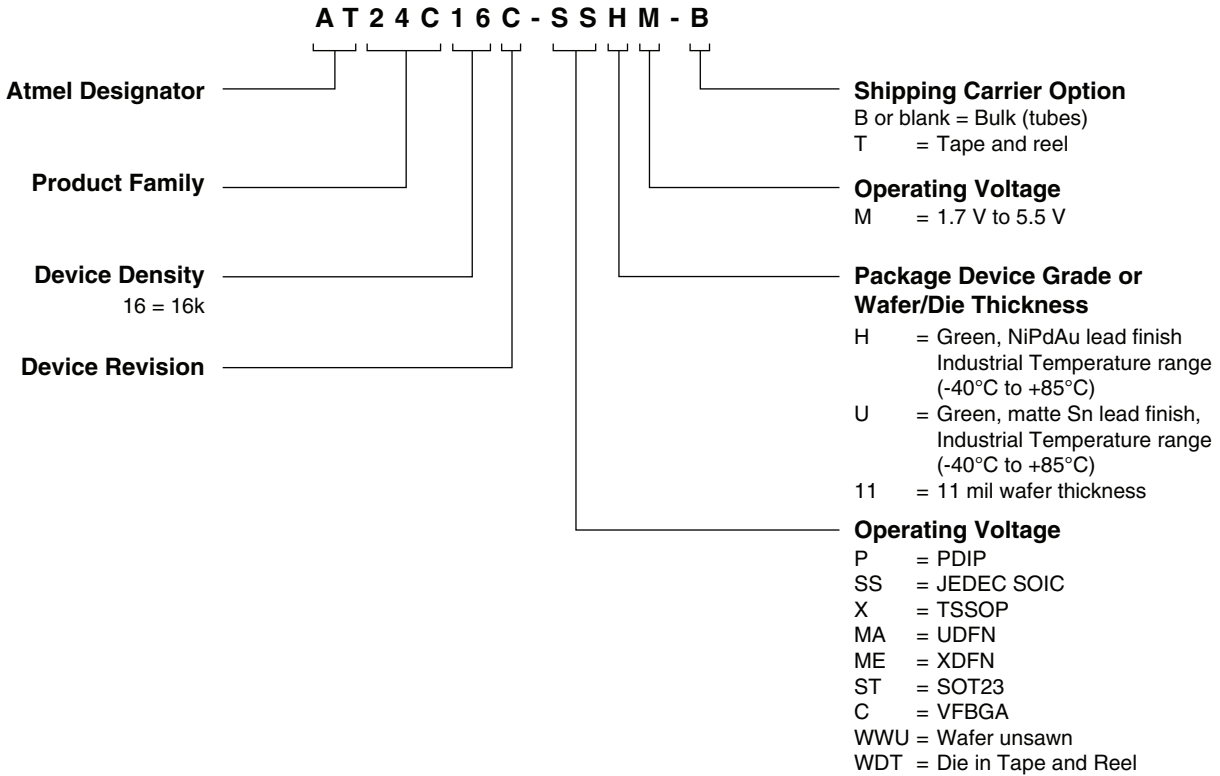

Figure 6-6. Sequential Read



7. Ordering Code Detail



8. Part Markings

Atmel AT24C16C-PUM

(TOP SIDE ONLY MARK)

```

|---|---|---|---|---|---|---|
 A   T   M   L   U   Y   W   W
|---|---|---|---|---|---|---|
 1   6   C   M           @
|---|---|---|---|---|---|---|
  ATMEL LOT NUMBER
|---|---|---|---|---|---|---|
 |
 PIN 1 INDICATOR (DOT)

```

LINE 1: AT=ATMEL H=MATERIAL SET/GRADE YWW=DATE CODE
 LINE 2: 16C=AT24C16C, M=1.7V to 5.5V, @=COUNTRY OF ASSEMBLY
 LINE 3: ATMEL LOT NUMBER

Atmel AT24C16C-SSHM

```

|---|---|---|---|---|---|---|
 A   T   M   L   H   Y   W   W
|---|---|---|---|---|---|---|
 1   6   C   M                               @
|---|---|---|---|---|---|---|
      ATMEL LOT NUMBER
|---|---|---|---|---|---|---|
|
PIN 1 INDICATOR (DOT)

```

LINE 1: ATML=ATMEL H=MATERIAL SET/GRADE YWW=DATE CODE
 LINE 2: 16C=AT24C16C, M=1.7 to 5.5V, @=COUNTRY OF ASSEMBLY
 LINE 3: ATMEL LOT NUMBER

Atmel AT24C16C-XHM

```

PIN 1 INDICATOR (DOT)
| |---|---|---|---|---|---|
 *  A   T   H   Y   W   W
   |---|---|---|---|---|---|
     1   6   C   M                               @
|---|---|---|---|---|---|---|
           ATMEL LOT NUMBER
|---|---|---|---|---|---|---|

```

LINE 1: AT=ATMEL, H=MATERIAL SET/GRADE, YWW=DATE CODE
 LINE 2: 16C=AT24C16C, M=1.7 to 5.5V, @=COUNTRY OF ASSEMBLY
 LINE 3: ATMEL LOT NUMBER

Atmel AT24C16C-MAHM

```

|---|---|---|
 1   6   C
|---|---|---|
  H   M   @
|---|---|---|
  Y   X   X
|---|---|---|
 *
|
PIN 1 INDICATOR (DOT)

```

LINE 1: 16C=AT24C16C
 LINE 2: H=MATERIAL SET/GRADE, M=1.7 to 5.5V, @=COUNTRY OF ASSEMBLY
 LINE 3: Y=DATE CODE, XX=Trace Code

Atmel AT24C16C-MEHM

```
|---|---|---|
 1  6  C
|---|---|---|
 Y  X  X
|---|---|---|
 *
 |
PIN 1 INDICATOR (DOT)
```

LINE 1: 16C=AT24C16C
LINE 2: Y=DATE CODE, XX=Trace Code

Atmel AT24C16C-STUM

```
TOP MARK
|---|---|---|---|---|
 1  6  C  M  U
|---|---|---|---|---|
 *
 |
PIN 1 INDICATOR (DOT)
```

Top Mark: 16C=AT24C16C, M=1.7v to 5.5V, U=MATERIAL SET/GRADE

```
BOTTOM SIDE MARKING
|---|---|---|---|
 Y  M  X  X
|---|---|---|---|
```

Bottom Mark: YM=DATE CODE
 XX=Trace Code

Atmel AT24C16C-CUM

```
|---|---|---|---|
 1  6  C  U
|---|---|---|---|
 Y  M  X  X
|---|---|---|---|
 |<-- PIN 1 This Corner
```

LINE 1: 16C=AT24C16C, U=MATERIAL SET/GRADE
LINE 2: YM=DATE CODE, XX=Trace Code

9. Ordering Codes

Atmel AT24C16C Ordering Information

Ordering Codes	Voltage	Package	Operating Range
AT24C16C-PUM (Bulk Form Only)	1.7 to 5.5	8P3	Lead-Free/Halogen-Free Industrial Temperature (-40°C to 85°C)
AT24C16C-SSHM-B ⁽¹⁾ (NiPdAu Lead Finish)	1.7 to 5.5	8S1	
AT24C16C-SSHM-T ⁽²⁾ (NiPdAu Lead Finish)	1.7 to 5.5	8S1	
AT24C16C-XHM-B ⁽¹⁾ (NiPdAu Lead Finish)	1.7 to 5.5	8A2	
AT24C16C-XHM-T ⁽²⁾ (NiPdAu Lead Finish)	1.7 to 5.5	8A2	
AT24C16C-MAHM-T ⁽²⁾ (NiPdAu Lead Finish)	1.7 to 5.5	8Y6	
AT24C16C-MEHM-T ⁽²⁾ (NiPdAu Lead Finish)	1.7 to 5.5	8ME1	
AT24C16C-STUM-T ⁽²⁾ (matte Sn)	1.7 to 5.5	5TS1	
AT24C16C-CUM-T ⁽²⁾ (matte Sn)	1.7 to 5.5	8U3-1	
AT24C16C-WWU11M ⁽³⁾	1.7 to 5.5	Die Sales	Industrial Temperature (-40°C to 85°C)

- Notes:
1. "-B" denotes bulk delivery
 2. "-T" denotes tape and reel delivery. SOIC = 4K/reel. TSSOP, UDFN, XDFN, SOT23, and VFBGA = 5K/reel
 3. For Wafer sales, please contact Atmel Sales

Package Type	
8P3	8-lead, 0.300" Wide, Plastic Dual Inline Package (PDIP)
8S1	8-lead, 0.150" Wide, Plastic Gull Wing Small Outline (JEDEC SOIC)
8A2	8-lead, 4.4mm Body, Plastic, Thin Shrink Small Outline Package (TSSOP)
8Y6	8-lead, 2.00mm x 3.00mm Body, 0.50mm Pitch, Ultra Thin Dual no Lead Package (UDFN)
8ME1	8-lead, 1.80mm x 2.20mm Body, (XDFN)
5TS1	5-lead, 1.60mm Body, Plastic Thin Shrink Small Outline Package (SOT-23)
8U3-1	8-ball, 1.50mm x 2.00mm Body, 0.50mm Pitch, Small Die Ball Grid Array (VFBGA)

10. Packaging Information

8P3 – PDIP

Top View

End View

Side View

COMMON DIMENSIONS
(Unit of Measure = inches)

SYMBOL	MIN	NOM	MAX	NOTE
A			0.210	2
A2	0.115	0.130	0.195	
b	0.014	0.018	0.022	5
b2	0.045	0.060	0.070	6
b3	0.030	0.039	0.045	6
c	0.008	0.010	0.014	
D	0.355	0.365	0.400	3
D1	0.005			3
E	0.300	0.310	0.325	4
E1	0.240	0.250	0.280	3
e	0.100 BSC			
eA	0.300 BSC			4
L	0.115	0.130	0.150	2

Notes:

- This drawing is for general information only; refer to JEDEC Drawing MS-001, Variation BA for additional information.
- Dimensions A and L are measured with the package seated in JEDEC seating plane Gauge GS-3.
- D, D1 and E1 dimensions do not include mold Flash or protrusions. Mold Flash or protrusions shall not exceed 0.010 inch.
- E and eA measured with the leads constrained to be perpendicular to datum.
- Pointed or rounded lead tips are preferred to ease insertion.
- b2 and b3 maximum dimensions do not include Dambar protrusions. Dambar protrusions shall not exceed 0.010 (0.25 mm).

07/19/10

Package Drawing Contact: packagedrawings@atmel.com	TITLE 8P3, 8-lead, 0.300" Wide Body, Plastic Dual In-line Package (PDIP)	GPC PTC	DRAWING NO. 8P3	REV. C

8S1 – JEDEC SOIC

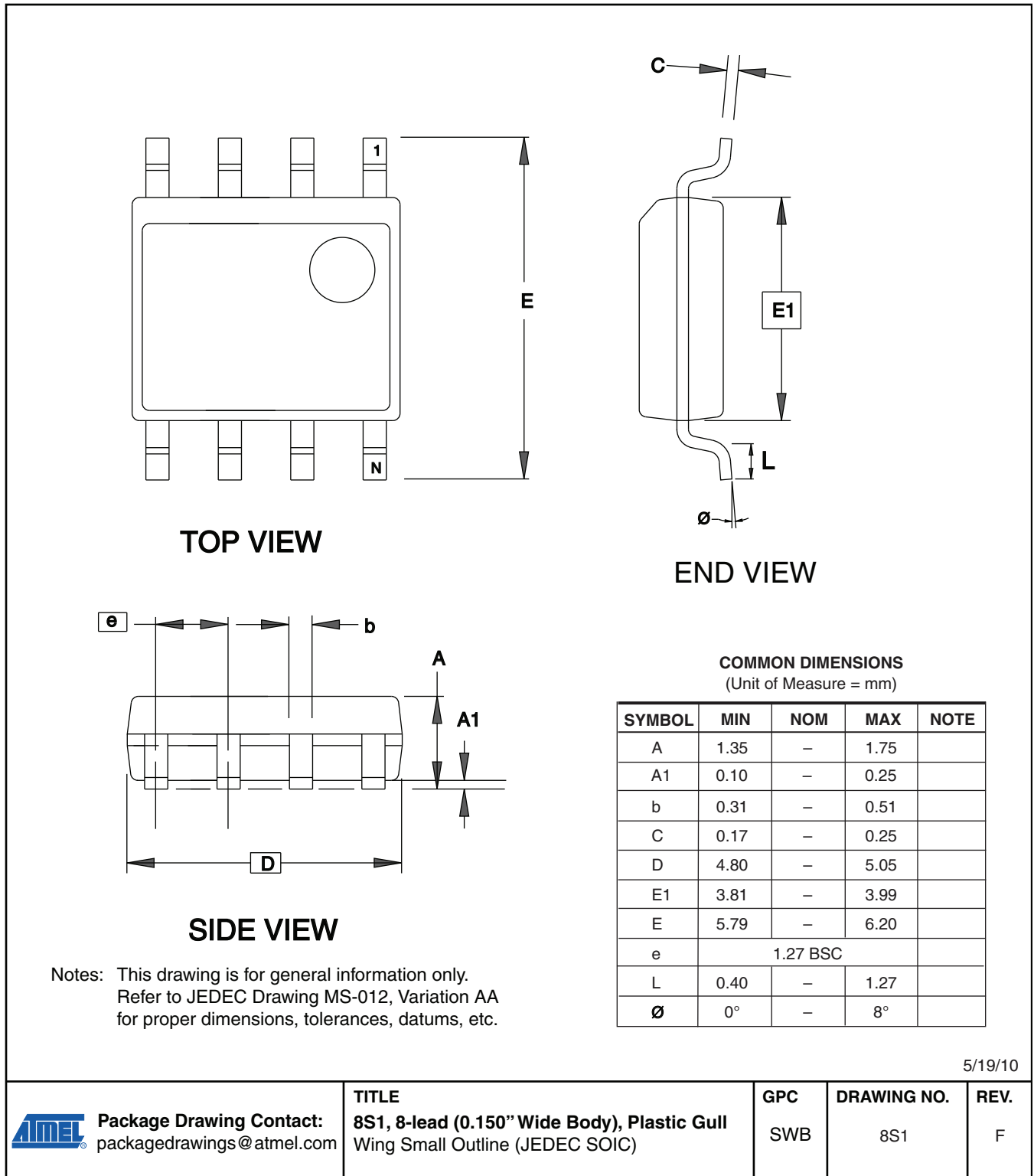

8A2 – TSSOP

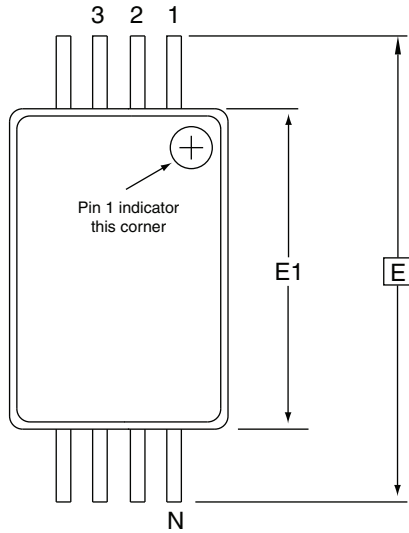

Top View

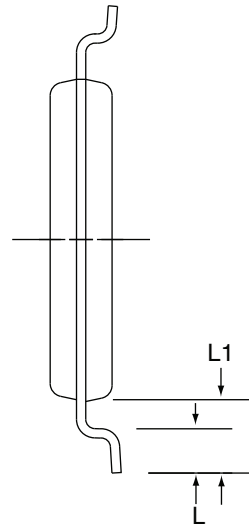

End View

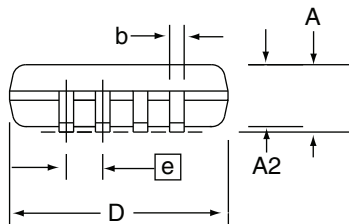

Side View

COMMON DIMENSIONS (Unit of Measure = mm)

SYMBOL	MIN	NOM	MAX	NOTE
D	2.90	3.00	3.10	2, 5
E	6.40 BSC			
E1	4.30	4.40	4.50	3, 5
A	–	–	1.20	
A2	0.80	1.00	1.05	
b	0.19	–	0.30	4
e	0.65 BSC			
L	0.45	0.60	0.75	
L1	1.00 REF			

- Notes:
1. This drawing is for general information only. Refer to JEDEC Drawing MO-153, Variation AA, for proper dimensions, tolerances, datums, etc.
 2. Dimension D does not include mold Flash, protrusions or gate burrs. Mold Flash, protrusions and gate burrs shall not exceed 0.15 mm (0.006 in) per side.
 3. Dimension E1 does not include inter-lead Flash or protrusions. Inter-lead Flash and protrusions shall not exceed 0.25 mm (0.010 in) per side.
 4. Dimension b does not include Dambar protrusion. Allowable Dambar protrusion shall be 0.08 mm total in excess of the b dimension at maximum material condition. Dambar cannot be located on the lower radius of the foot. Minimum space between protrusion and adjacent lead is 0.07 mm.
 5. Dimension D and E1 to be determined at Datum Plane H.

5/19/10



Package Drawing Contact:
packagedrawings@atmel.com

TITLE
8A2, 8-lead 4.4mm Body, Plastic Thin
Shrink Small Outline Package (TSSOP)

GPC
TNR

DRAWING NO.
8A2

REV.
E

8Y6 – Mini Map

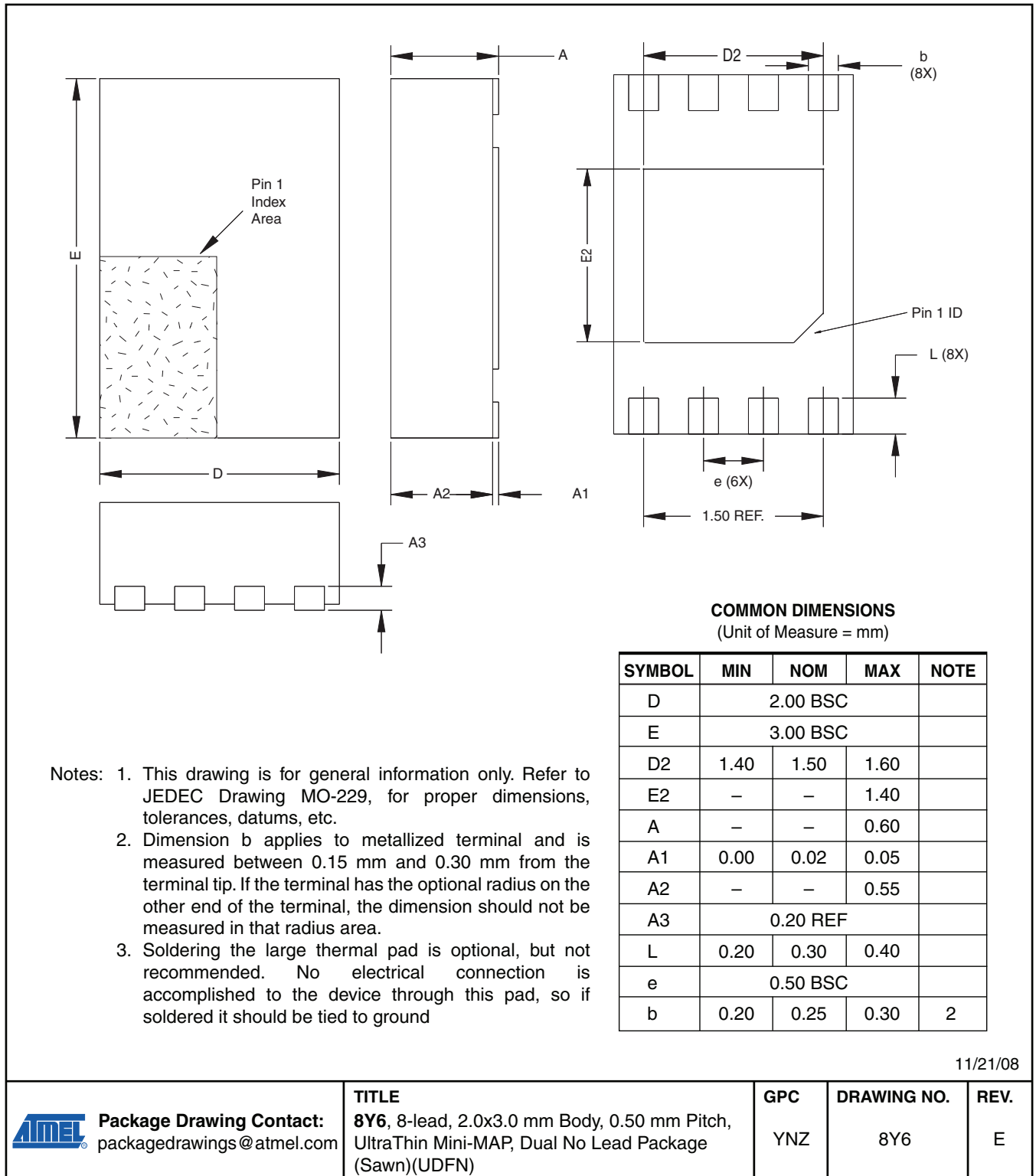

8ME1 – XDFN

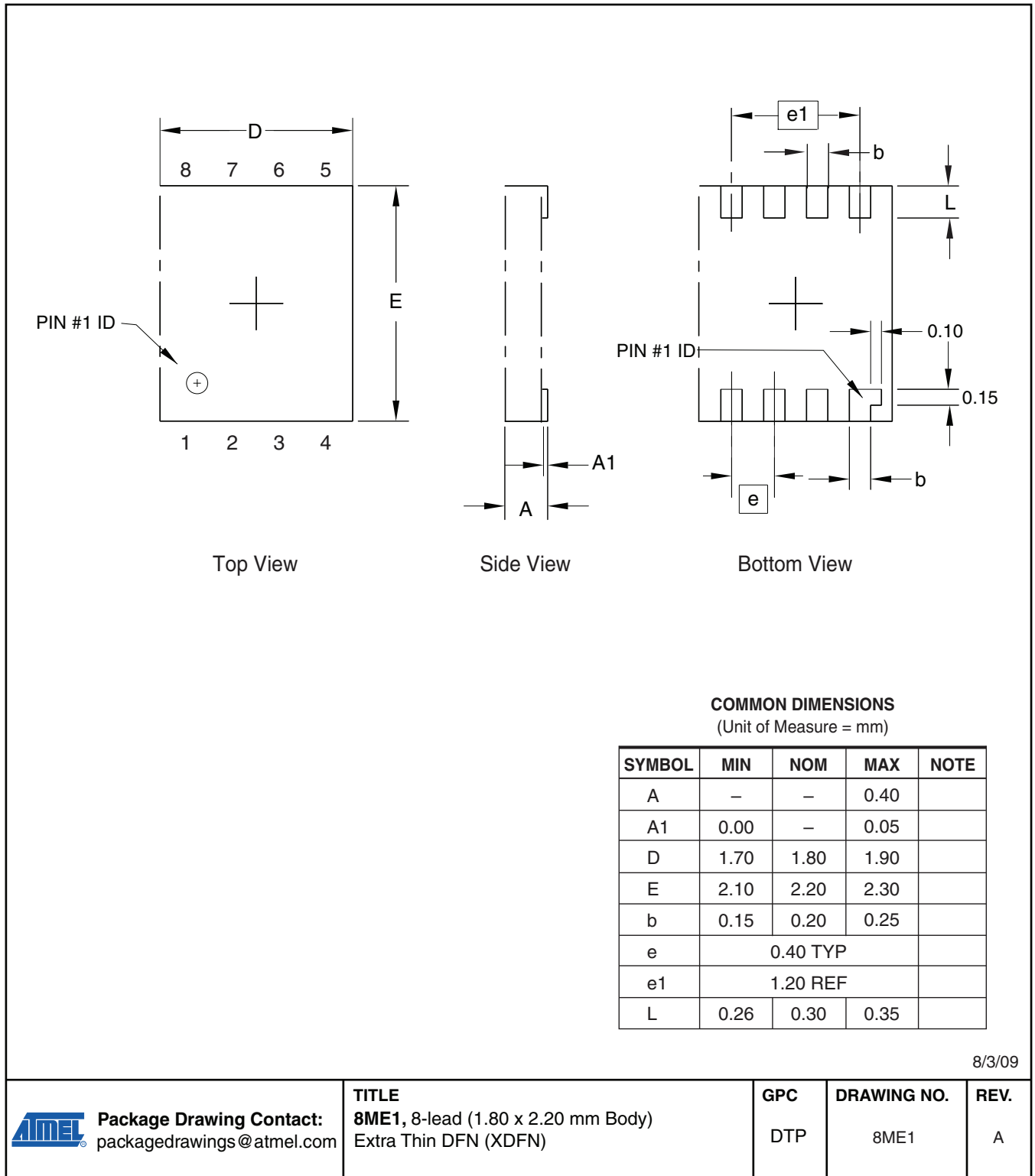

5TS1 – SOT23

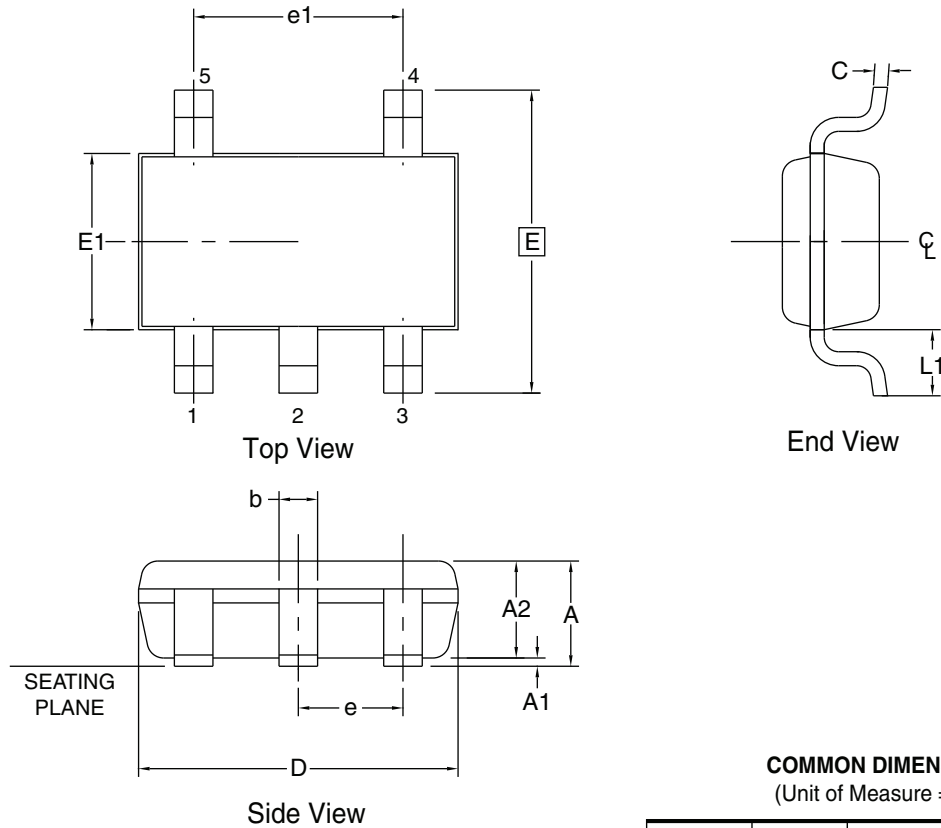

COMMON DIMENSIONS
(Unit of Measure = mm)

SYMBOL	MIN	NOM	MAX	NOTE
A	–	–	1.10	
A1	0.00	–	0.10	
A2	0.70	0.90	1.00	
c	0.08	–	0.20	3
D	2.90 BSC			1, 2
E	2.80 BSC			1, 2
E1	1.60 BSC			1, 2
L1	0.60 REF			
e	0.95 BSC			
e1	1.90 BSC			
b	0.30	–	0.50	3, 4

- Notes:
- Dimensions D does not include mold flash, protrusions or gate burrs. Mold flash protrusions or gate burrs shall not exceed 0.15 mm per end. Dimensions E1 does not include interlead flash or protrusion. Interlead flash or protrusion shall not exceed 0.15 mm per side.
 - The package top may be smaller than the package bottom. Dimensions D and E1 are determined at the outermost extremes of the plastic body exclusive of mold flash, tie bar burrs, gate burrs, and interlead flash, but including any mismatch between the top and bottom of the plastic body.
 - These dimensions apply to the flat section of the lead between 0.08 mm and 0.15 mm from the lead tip.
 - Dimension "b" does not include dambar protrusion. Allowable dambar protrusion shall be 0.80 mm total in excess of the "b" dimension at maximum material condition. The dambar cannot be located on the lower radius of the foot. Minimum space between protrusion and an adjacent lead shall not be less than 0.07 mm.
 - This drawing is for general information only. Refer to JEDEC Drawing MO-193, Variation AB for additional information.

11/05/08



Package Drawing Contact:
packagedrawings@atmel.com

TITLE
5TS1, 5-lead, 1.60 mm Body, Plastic Thin
Shrink Small Outline Package (Shrink SOT)

GPC
TSZ

DRAWING NO.
5TS1

REV.
B

8U3-1 – dBGA2

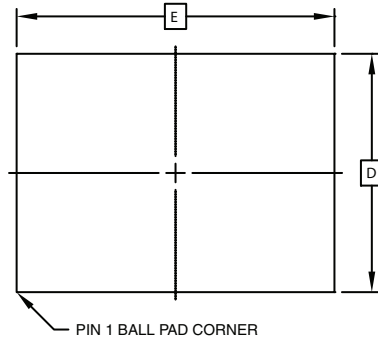

TOP VIEW

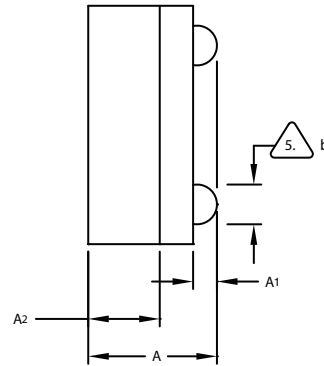

SIDE VIEW

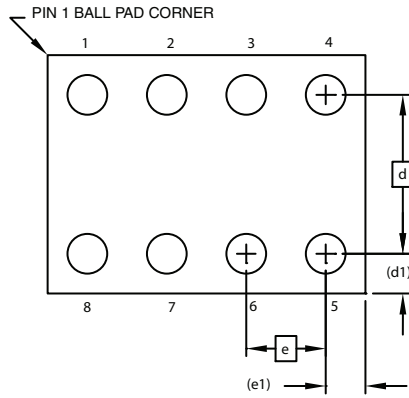

BOTTOM VIEW
8 SOLDER BALLS

COMMON DIMENSIONS
(Unit of Measure - mm)

SYMBOL	MIN	NOM	MAX	NOTE
A	0.73	0.79	0.85	
A1	0.09	0.14	0.19	
A2	0.40	0.45	0.50	
b	0.20	0.25	0.30	2
D	1.50 BSC			
E	2.0 BSC			
e	0.50 BSC			
e1	0.25 REF			
d	1.00 BSC			
d1	0.25 REF			

Notes:

1. This drawing is for general information only.
2. Dimension 'b' is measured at maximum solder ball diameter.
3. Solder ball composition shall be 95.5Sn-4.0Ag-.5Cu.

07/14/10



Package Drawing Contact:
packagedrawings@atmel.com

TITLE
8U3-1, 8-ball, 1.50 x 2.00 mm Body,
0.50 pitch, VFBGA Package (dBGA2)

GPC
GXU

DRAWING NO.
8U3-1

REV.
D

11. Revision History

Doc. Rev.	Date	Comments
8719A	09/2010	Initial document release



Product Contact

Product Line

s_eeeprom@atmel.com

Sales Contact

www.atmel.com/contacts

Literature Requests

www.atmel.com/literature

Atmel Corporation

2325 Orchard Parkway
San Jose, CA 95131
USA

Tel: (+1) (408) 441-0311

Fax: (+1) (408) 487-2600

www.atmel.com

Atmel Asia Limited

Unit 01-5 & 16, 19F
BEA Tower, Millennium City 5
418 Kwun Tong Road
Kwun Tong, Kowloon
HONG KONG

Tel: (+852) 2245-6100

Fax: (+852) 2722-1369

Atmel Munich GmbH

Business Campus
Parkring 4
D-85748 Garching b. Munich
GERMANY

Tel: (+49) 89-31970-0

Fax: (+49) 89-3194621

Atmel Japan

9F, Tonetsu Shinkawa Bldg.
1-24-8 Shinkawa
Chuo-ku, Tokyo 104-0033
JAPAN

Tel: (+81) (3) 3523-3551

Fax: (+81) (3) 3523-7581

© 2010 Atmel Corporation. All rights reserved. / Rev.: **8719A-SEEPR-9/10**

Atmel®, Atmel logo and combinations thereof and others, are registered trademarks or trademarks of Atmel Corporation or its subsidiaries. Other terms and product names may be trademarks of others.

Disclaimer: The information in this document is provided in connection with Atmel products. No license, express or implied, by estoppel or otherwise, to any intellectual property right is granted by this document or in connection with the sale of Atmel products. EXCEPT AS SET FORTH IN THE ATMEL TERMS AND CONDITIONS OF SALES LOCATED ON THE ATMEL WEBSITE, ATMEL ASSUMES NO LIABILITY WHATSOEVER AND DISCLAIMS ANY EXPRESS, IMPLIED OR STATUTORY WARRANTY RELATING TO ITS PRODUCTS INCLUDING, BUT NOT LIMITED TO, THE IMPLIED WARRANTY OF MERCHANTABILITY, FITNESS FOR A PARTICULAR PURPOSE, OR NON-INFRINGEMENT. IN NO EVENT SHALL ATMEL BE LIABLE FOR ANY DIRECT, INDIRECT, CONSEQUENTIAL, PUNITIVE, SPECIAL OR INCIDENTAL DAMAGES (INCLUDING, WITHOUT LIMITATION, DAMAGES FOR LOSS AND PROFITS, BUSINESS INTERRUPTION, OR LOSS OF INFORMATION) ARISING OUT OF THE USE OR INABILITY TO USE THIS DOCUMENT, EVEN IF ATMEL HAS BEEN ADVISED OF THE POSSIBILITY OF SUCH DAMAGES. Atmel makes no representations or warranties with respect to the accuracy or completeness of the contents of this document and reserves the right to make changes to specifications and products descriptions at any time without notice. Atmel does not make any commitment to update the information contained herein. Unless specifically provided otherwise, Atmel products are not suitable for, and shall not be used in, automotive applications. Atmel products are not intended, authorized, or warranted for use as components in applications intended to support or sustain life.