

I²C-Compatible, (2-wire) Serial EEPROM 4-Kbit (512 x 8), 8-Kbit (1024 x 8)

DATASHEET

Standard Features

- Low-voltage and standard-voltage operation
 - $V_{CC} = 1.7V$ to $5.5V$
- Internally organized as 512 x 8 (4K), or 1024 x 8 (8K)
- I²C-compatible (2-wire) serial interface
- Schmitt Trigger, filtered inputs for noise suppression
- Bidirectional data transfer protocol
- 1MHz (2.5V, 2.7V, 5V), 400kHz (1.7V) compatibility
- Write Protect pin for hardware data protection
- 16-byte Page Write mode
 - Partial page writes allowed
- Self-timed write cycle (5ms max)
- High-reliability
 - Endurance: 1 million write cycles
 - Data retention: 100 years
- Green package options (Pb/Halide-free/RoHS compliant)
 - 8-lead PDIP, 8-lead SOIC, 8-lead TSSOP, 8-pad UDFN, 5-lead SOT23, and 8-ball VFBGA
- Die options: wafer form and tape and reel

Description

The Atmel® AT24C04C and AT24C08C provides 4096/8192 bits of Serial Electrically Erasable and Programmable Read-Only Memory (EEPROM) organized as 512/1024 words of eight bits each. The device is optimized for use in many industrial and commercial applications where low-power and low-voltage operation are essential. AT24C04C/08C is available in space-saving 8-lead PDIP, 8-lead JEDEC SOIC, 8-lead TSSOP, 8-pad UDFN, 5-lead SOT23, and 8-ball VFBGA packages and is accessed via a 2-wire serial interface.

Table 1. Pin Configuration

Pin Name	Function
NC	No Connect
A ₁	Address input (4K only)
A ₂	Address input
SDA	Serial data
SCL	Serial clock input
WP	Write protect
GND	Ground
V _{CC}	Power supply

Note: 1. For use of 5-lead SOT23, the software A2 and A1 bits in the device address word must be set to zero to properly communicate.

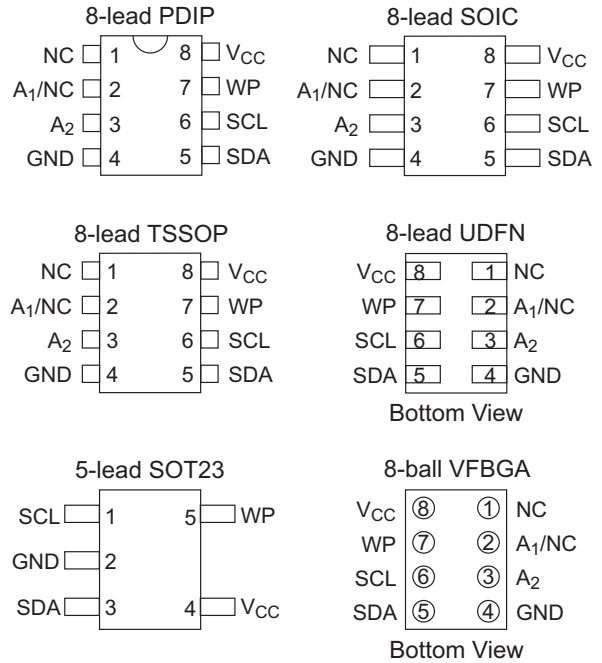

1. Absolute Maximum Ratings

Operating Temperature	-55°C to +125°C
Storage Temperature	-65°C to +150°C
Voltage on any pin with respect to ground	-1.0V to +7.0V
Maximum Operating Voltage	6.25V
DC Output Current.....	5.0mA

*Notice: Stresses beyond those listed under “Absolute Maximum Ratings” may cause permanent damage to the device. This is a stress rating only and functional operation of the device at these or any other conditions beyond those indicated in the operational sections of this specification is not implied. Exposure to absolute maximum rating conditions for extended periods may affect device reliability.

2. Block Diagram

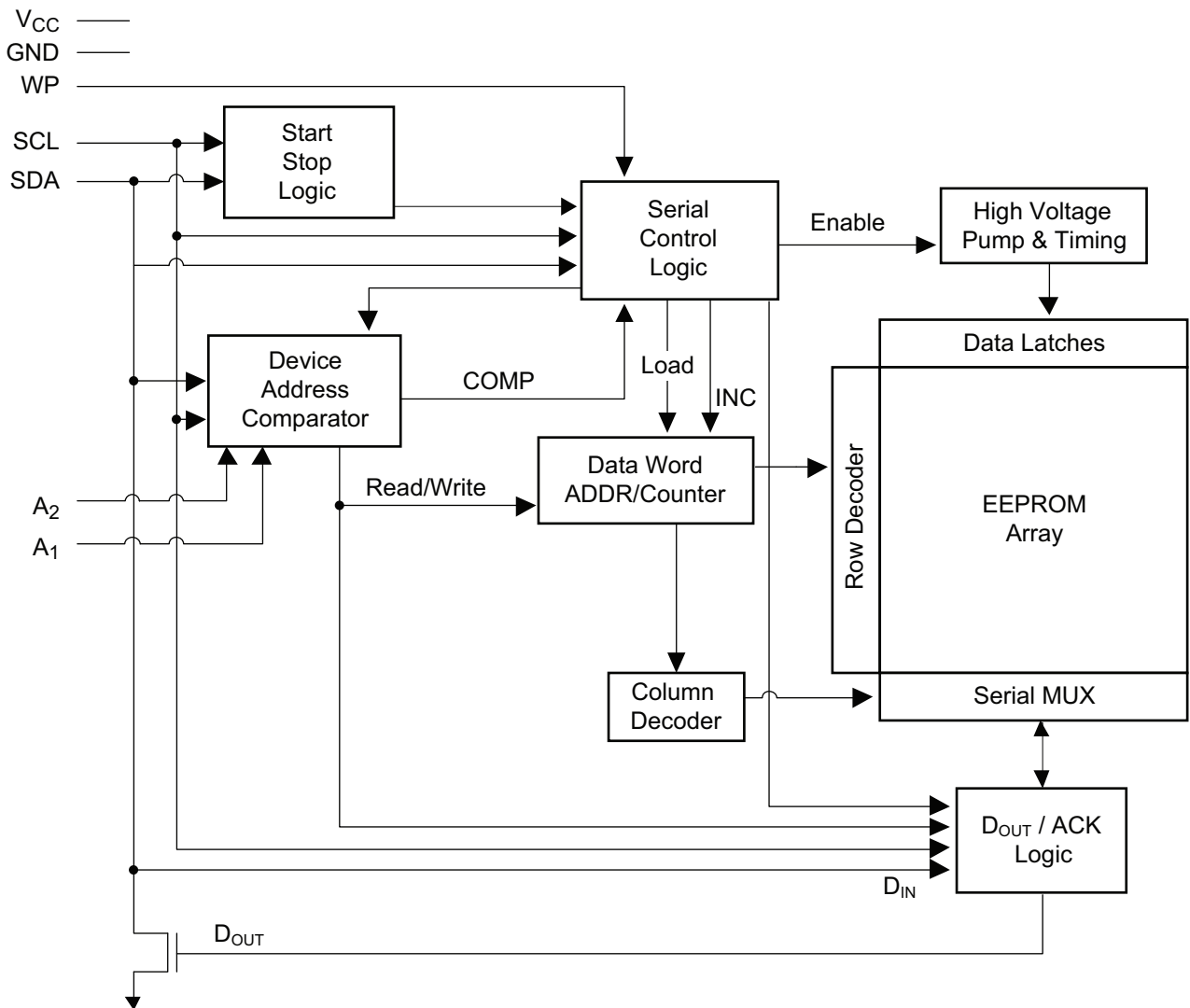

3. Pin Description

Serial Clock (SCL): The SCL input is used to positive edge clock data into each EEPROM device and negative edge clock data out of each device.

Serial Data (SDA): The SDA pin is bidirectional for serial data transfer. This pin is open-drain driven and may be wire-ORed with any number of other open-drain or open-collector devices.

Device/Page Addresses (A_2 and A_1): The AT24C04C uses the A_2 and A_1 inputs for hard wire addressing allowing a total of four 4K devices to be addressed on a single bus system. Pin 1 is a no connect and can be connected to ground (see [Section 6. "Device Addressing" on page 10](#)). The AT24C08C only uses the A_2 input for hardware addressing and a total of two 8K devices may be addressed on a single bus system. The A_0 and A_1 pins are no connects and can be connected to ground (see [Section 6. "Device Addressing" on page 10](#)).

Write Protect (WP): AT24C04C/08C has a Write Protect pin that provides hardware data protection. The Write Protect pin allows normal read/write operations when connected to Ground (GND). When the Write Protect pin is connected to V_{CC} , the write protection feature is enabled and operates as shown in [Table 3-1](#).

Table 3-1. Write Protect

WP Pin Status	Part of the Array Protected
	Atmel AT24C04C/08C
At V_{CC}	Full array
At GND	Normal read/write operations

4. Memory Organization

Atmel AT24C04C, 4K Serial EEPROM: Internally organized with 32 pages of 16 bytes each, the 4K requires a 9-bit data word address for random word addressing.

Atmel AT24C08C, 8K Serial EEPROM: Internally organized with 64 pages of 16 bytes each, the 8K requires a 10-bit data word address for random word addressing.

Table 4-1. Pin Capacitance⁽¹⁾

Applicable over recommended operating range from $T_A = 25^\circ\text{C}$, $f = 1.0\text{MHz}$, $V_{CC} = +1.7\text{V}$ to $+5.5\text{V}$

Symbol	Test Condition	Max	Units	Conditions
$C_{I/O}$	Input/Output capacitance (SDA)	8	pF	$V_{I/O} = 0\text{V}$
C_{IN}	Input capacitance ($A_0, A_1, A_2, \text{SCL}$)	6	pF	$V_{IN} = 0\text{V}$

Note: 1. This parameter is characterized and is not 100% tested.

Table 4-2. DC Characteristics

Applicable over recommended operating range from: $T_{AI} = -40^\circ\text{C}$ to $+85^\circ\text{C}$, $V_{CC} = +1.7\text{V}$ to $+5.5\text{V}$ (unless otherwise noted)

Symbol	Parameter	Test Condition	Min	Typ	Max	Units
V_{CC1}	Supply Voltage		1.7		5.5	V
V_{CC2}	Supply Voltage		4.5		5.5	V
I_{CC}	Supply Current $V_{CC} = 5.0\text{V}$	Read at 100kHz		0.4	1.0	mA
I_{CC}	Supply Current $V_{CC} = 5.0\text{V}$	Write at 100kHz		2.0	3.0	mA
I_{SB1}	Standby Current $V_{CC} = 1.7\text{V}$	$V_{IN} = V_{CC}$ or V_{SS}			1.0	μA
I_{SB2}	Standby Current $V_{CC} = 5.5\text{V}$	$V_{IN} = V_{CC}$ or V_{SS}			6.0	μA
I_{LI}	Input Leakage Current	$V_{IN} = V_{CC}$ or V_{SS}		0.10	3.0	μA
I_{LO}	Output Leakage Current	$V_{OUT} = V_{CC}$ or V_{SS}		0.05	3.0	μA
V_{IL}	Input Low Level ⁽¹⁾		-0.6		$V_{CC} \times 0.3$	V
V_{IH}	Input High Level ⁽¹⁾		$V_{CC} \times 0.7$		$V_{CC} + 0.5$	V
V_{OL2}	Output Low Level $V_{CC} = 3.0\text{V}$	$I_{OL} = 2.1\text{mA}$			0.4	V
V_{OL1}	Output Low Level $V_{CC} = 1.7\text{V}$	$I_{OL} = 0.15\text{mA}$			0.2	V

Note: 1. V_{IL} min and V_{IH} max are reference only and are not tested.

Table 4-3. AC Characteristics

Applicable over recommended operating range from $T_{AI} = -40^{\circ}\text{C}$ to $+85^{\circ}\text{C}$, $V_{CC} = +1.7\text{V}$ to $+5.5\text{V}$,
 $CL = 1\text{TTL Gate and } 100\text{pF}$ (unless otherwise noted)

Symbol	Parameter	1.7V		2.5V, 2.7V, 5.0V		Units
		Min	Max	Min	Max	
f_{SCL}	Clock Frequency, SCL		400		1000	kHz
t_{LOW}	Clock Pulse Width Low	1.2		0.4		μs
t_{HIGH}	Clock Pulse Width High	0.6		0.4		μs
t_i	Noise Suppression Time		100		50	ns
t_{AA}	Clock Low to Data Out Valid	0.1	0.9	0.05	0.55	μs
t_{BUF}	Time the bus must be free before a new transmission can start.	1.2		0.5		μs
$t_{HD,STA}$	Start Hold Time	0.6		0.25		μs
$t_{SU,STA}$	Start Setup Time	0.6		0.25		μs
$t_{HD,DAT}$	Data In Hold Time	0		0		μs
$t_{SU,DAT}$	Data In Setup Time	100		100		ns
t_R	Inputs Rise Time ⁽¹⁾		0.3		0.3	μs
t_F	Inputs Fall Time ⁽¹⁾		300		100	ns
$t_{SU,STO}$	Stop Setup Time	0.6		.25		μs
t_{DH}	Data Out Hold Time	50		50		ns
t_{WR}	Write Cycle Time		5		5	ms
Endurance ⁽¹⁾	3.3V, +25°C, Page Mode	1 Million				Write Cycles

Note: 1. This parameter is ensured by characterization only.

5. Device Operation

Clock and Data Transitions: The SDA pin is normally pulled high with an external device. Data on the SDA pin may change only during SCL low time periods (see [Figure 5-4 on page 9](#)). Data changes during SCL high periods will indicate a Start or Stop condition as defined below.

Start Condition: A high-to-low transition of SDA with SCL high is a Start condition which must precede any other command (see [Figure 5-5 on page 9](#)).

Stop Condition: A low-to-high transition of SDA with SCL high is a Stop condition. After a read sequence, the Stop command will place the EEPROM in a standby power mode (see [Figure 5-5 on page 9](#)).

Acknowledge: All addresses and data words are serially transmitted to and from the EEPROM in eight bit words. The EEPROM sends a zero to acknowledge that it has received each word. This happens during the ninth clock cycle.

Standby Mode: The Atmel AT24C04/08C features a low-power standby mode which is enabled:

- Upon power-up
- After the receipt of the Stop bit and the completion of any internal operations

2-wire Software Reset: After an interruption in protocol, power loss or system reset, any 2-wire part can be reset by following these steps:

1. Create a start bit condition
2. Clock nine cycles
3. Create another start bit followed by stop bit condition as shown below.

The device is ready for next communication after above steps have been completed.

Figure 5-1. Software Reset

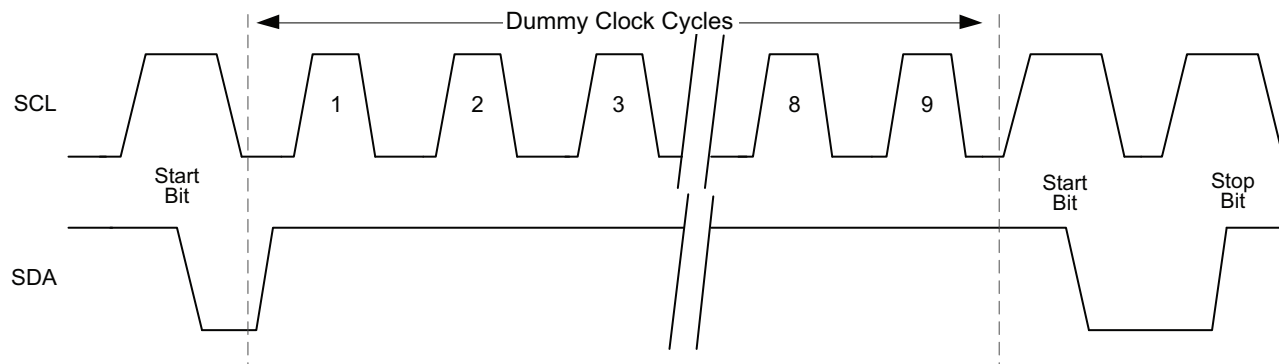

Figure 5-2. Bus Timing

SCL: Serial Clock, SDA: Serial Data I/O

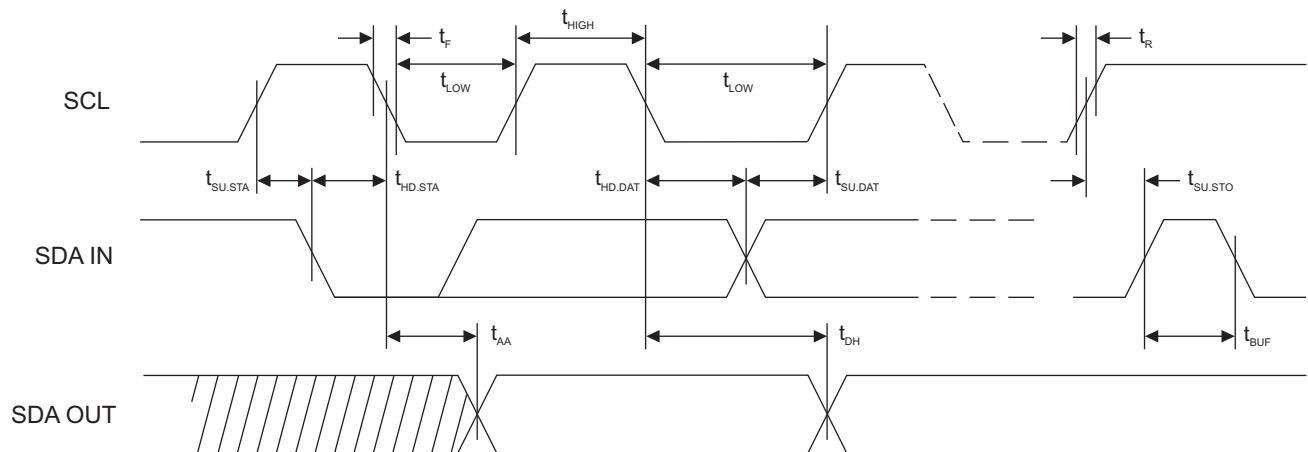
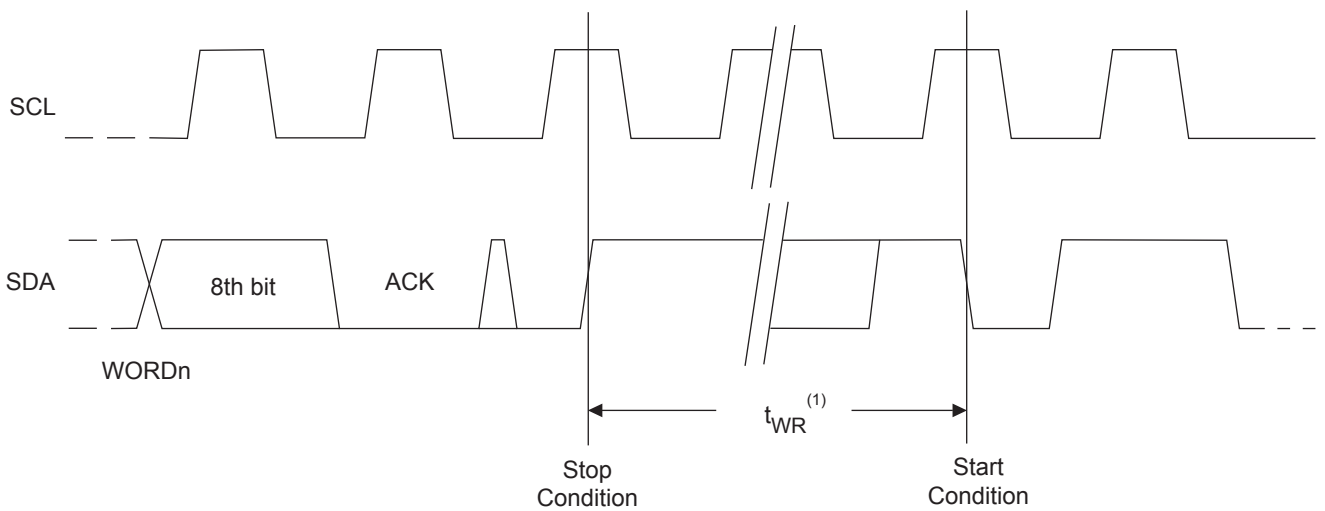

Figure 5-3. Write Cycle Timing

SCL: Serial Clock, SDA: Serial Data I/O



Notes: 1. The write cycle time t_{WR} is the time from a valid Stop condition of a write sequence to the end of the internal clear/write cycle.

Figure 5-4. Data Validity

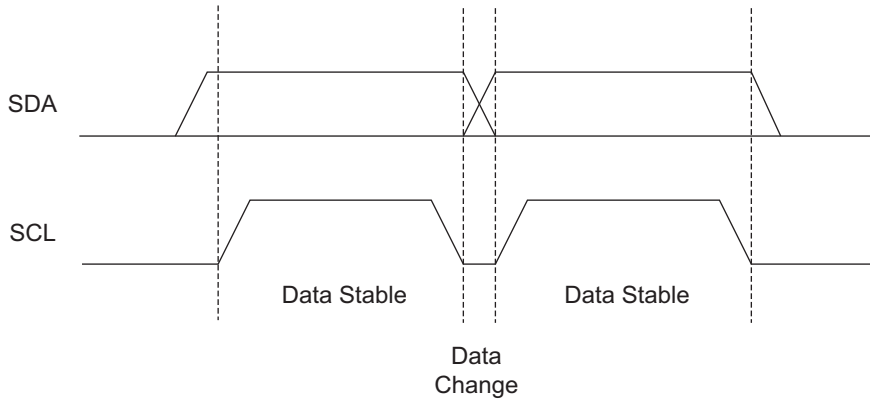

Figure 5-5. Start and Stop Definition

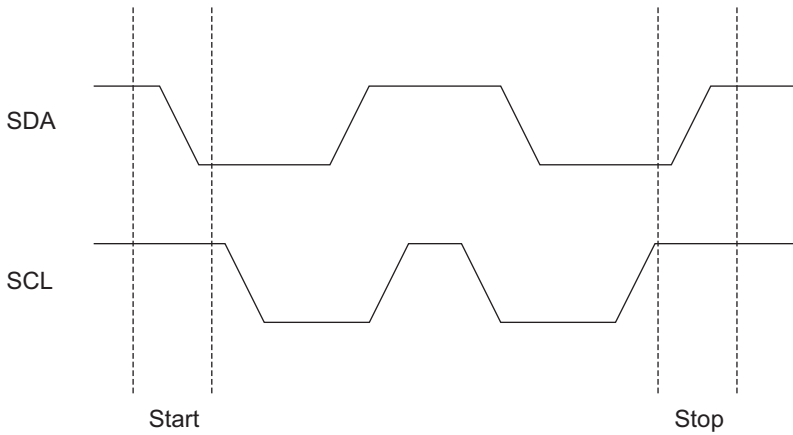
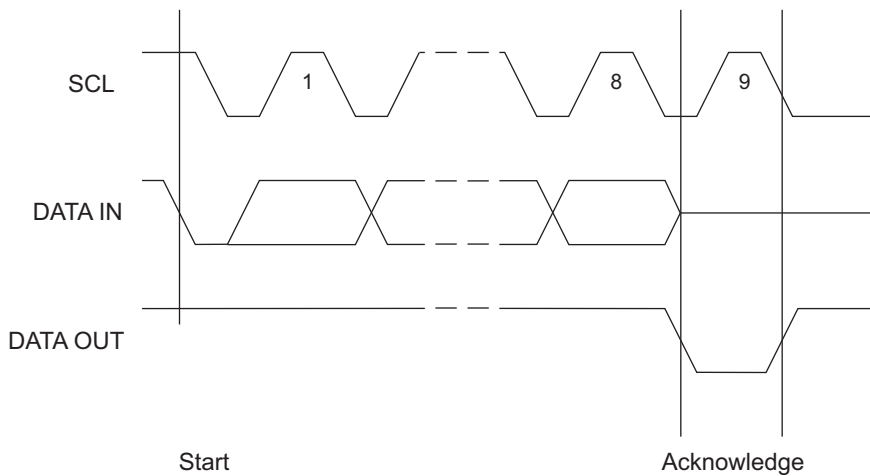

Figure 5-6. Output Acknowledge



6. Device Addressing

Standard EEPROM Access: The 4K and 8K EEPROM device requires an 8-bit device address word following a start condition to enable the chip for a read or write operation. The device address word consists of a mandatory “1010” (0xA) sequence for the first four Most Significant Bits (MSB) as shown in [Figure 8-1 on page 11](#). This is common to all the EEPROM devices.

The 4K EEPROM only uses the A₂ and A₁ device address bits with the third bit being a memory page address bit. The two device address bits must compare to their corresponding hard-wired input pins. The A₀ pin is no connect.

The 8K EEPROM only uses the A₂ device address bit with the next two bits being for memory page addressing. The A₂ address bit must compare to its corresponding hard-wired input pin. The A₁ and A₀ pins are no connect.

The eighth bit of the device address is the read/write operation select bit. A read operation is initiated if this bit is high and a write operation is initiated if this bit is low.

Upon a compare of the device address, the EEPROM will output a zero. If a compare is not made, the chip will return to a standby state.

For the SOT23 package offering, the 4K EEPROM software A₂ and A₁ bits in the device address word must be set to zero to properly communicate. The 8K EEPROM software A₂ bit in the device address word must be set to zero to properly communicate.

7. Write Operations

Byte Write: A write operation requires an 8-bit data word address following the device address word and acknowledgment. Upon receipt of this address, the EEPROM will again respond with a zero and then clock in the first 8-bit data word. Following receipt of the 8-bit data word, the EEPROM will output a zero and the addressing device, such as a microcontroller, must terminate the write sequence with a Stop condition. At this time the EEPROM enters an internally timed write cycle, t_{WR} , to the nonvolatile memory. All inputs are disabled during this write cycle and the EEPROM will not respond until the write is complete (see [Figure 8-2 on page 11](#)).

Page Write: The 4K and 8K EEPROM devices are capable of a 16-byte Page Write.

A Page Write is initiated in the same way as a Byte Write, but the microcontroller does not send a Stop condition after the first data word is clocked in. Instead, after the EEPROM acknowledges receipt of the first data word, the microcontroller can transmit up to fifteen more data words. The EEPROM will respond with a zero after each data word received. The microcontroller must terminate the Page Write sequence with a Stop condition (see [Figure 8-3 on page 12](#)).

The data word address lower four bits are internally incremented following the receipt of each data word. The higher data word address bits are not incremented, retaining the memory page row location. When the word address, internally generated, reaches the page boundary, the following byte is placed at the beginning of the same page. If more than eight data words are transmitted to the EEPROM, the data word address will “roll over” and previous data will be overwritten.

Acknowledge Polling: Once the internally timed write cycle has started and the EEPROM inputs are disabled, Acknowledge Polling can be initiated. This involves sending a Start condition followed by the device address word. The read/write bit is representative of the operation desired. Only if the internal write cycle has completed will the EEPROM respond with a zero allowing the read or write sequence to continue.

8. Read Operations

Read operations are initiated in the same way as write operations with the exception that the read/write select bit in the device address word is set to one. There are three read operations: Current Address Read, Random Address Read, and Sequential Read.

Current Address Read: The internal data word address counter maintains the last address accessed during the last read or write operation, incremented by one. This address stays valid between operations as long as the chip power is maintained. The address “roll over” during read is from the last byte of the last memory page to the first byte of the first page. The address “roll over” during write is from the last byte of the current page to the first byte of the same page.

Once the device address with the read/write select bit set to one is clocked in and acknowledged by the EEPROM, the current address data word is serially clocked out. The microcontroller does not respond with an input zero but does generate a following stop condition (see [Figure 8-4 on page 12](#)).

Random Read: A random read requires a “dummy” byte write sequence to load in the data word address. Once the device address word and data word address are clocked in and acknowledged by the EEPROM, the microcontroller must generate another start condition. The microcontroller now initiates a Current Address Read by sending a device address with the read/write select bit high. The EEPROM acknowledges the device address and serially clocks out the data word. The microcontroller does not respond with a zero but does generate a following stop condition (see [Figure 8-5 on page 12](#)).

Sequential Read: Sequential Reads are initiated by either a Current Address Read or a Random Address Read. After the microcontroller receives a data word, it responds with an Acknowledge. As long as the EEPROM receives an Acknowledge, it will continue to increment the data word address and serially clock out sequential data words. When the memory address limit is reached, the data word address will “roll over” and the Sequential Read will continue. The Sequential Read operation is terminated when the microcontroller does not respond with a zero but does generate a following Stop condition (see [Figure 8-6 on page 12](#)).

Figure 8-1. Device Address

Density	Access Area	Bit 7	Bit 6	Bit 5	Bit 4	Bit 3	Bit 2	Bit 1	Bit 0
4K	EEPROM	1	0	1	0	A ₂	A ₁	P0	R \overline{W}
8K	EEPROM	1	0	1	0	A ₂	P1	P0	R \overline{W}

MSB LSB

Figure 8-2. Byte Write

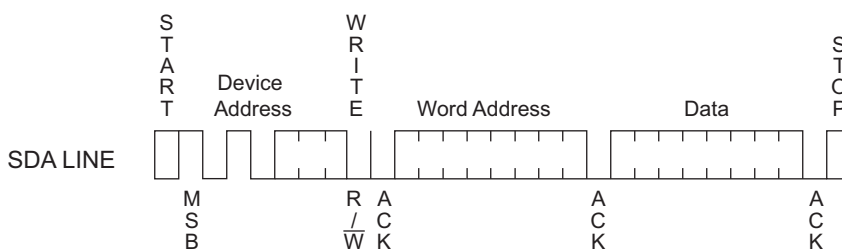

Figure 8-3. Page Write

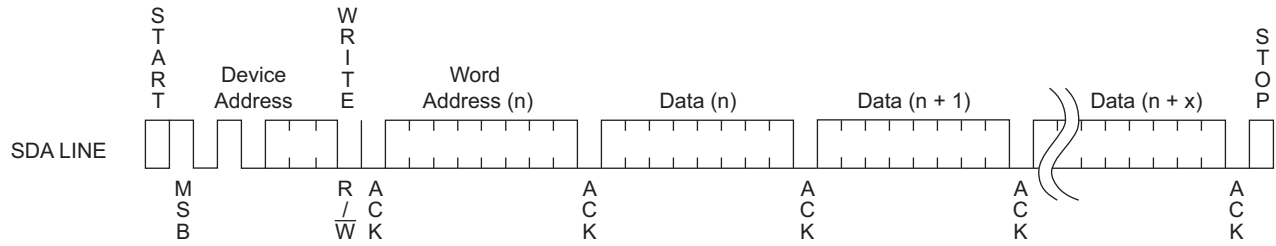

Figure 8-4. Current Address Read

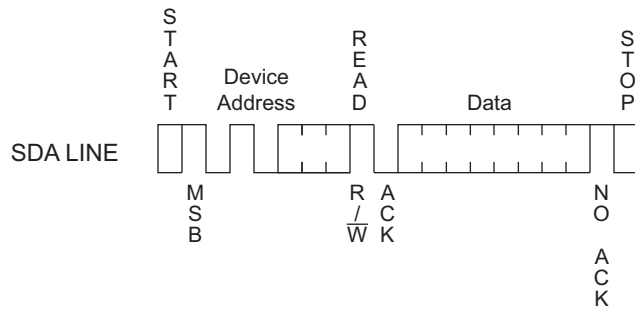

Figure 8-5. Random Read

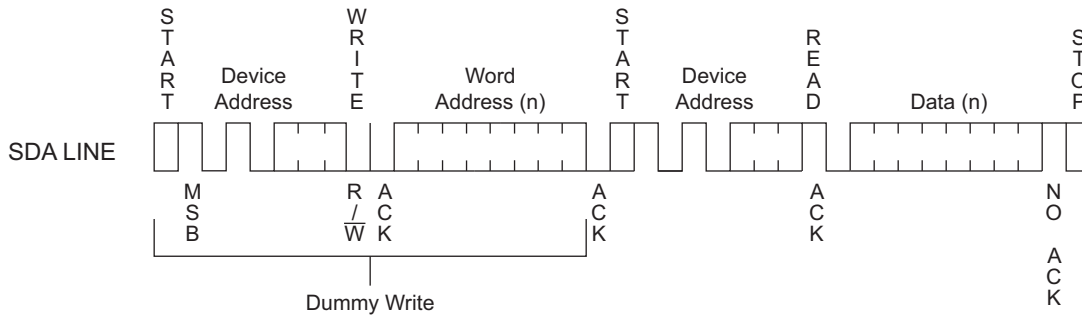
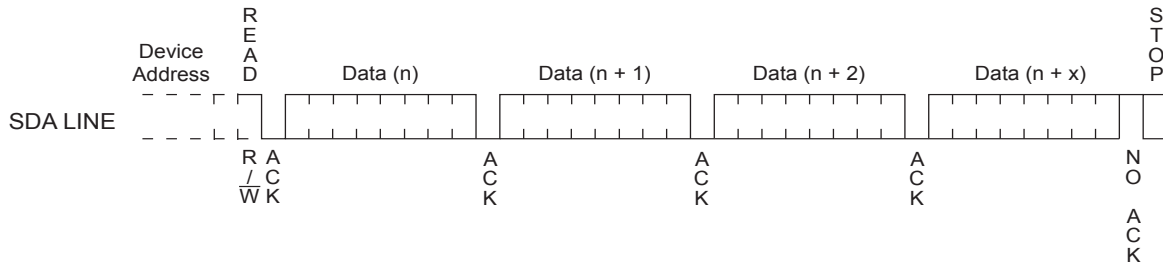
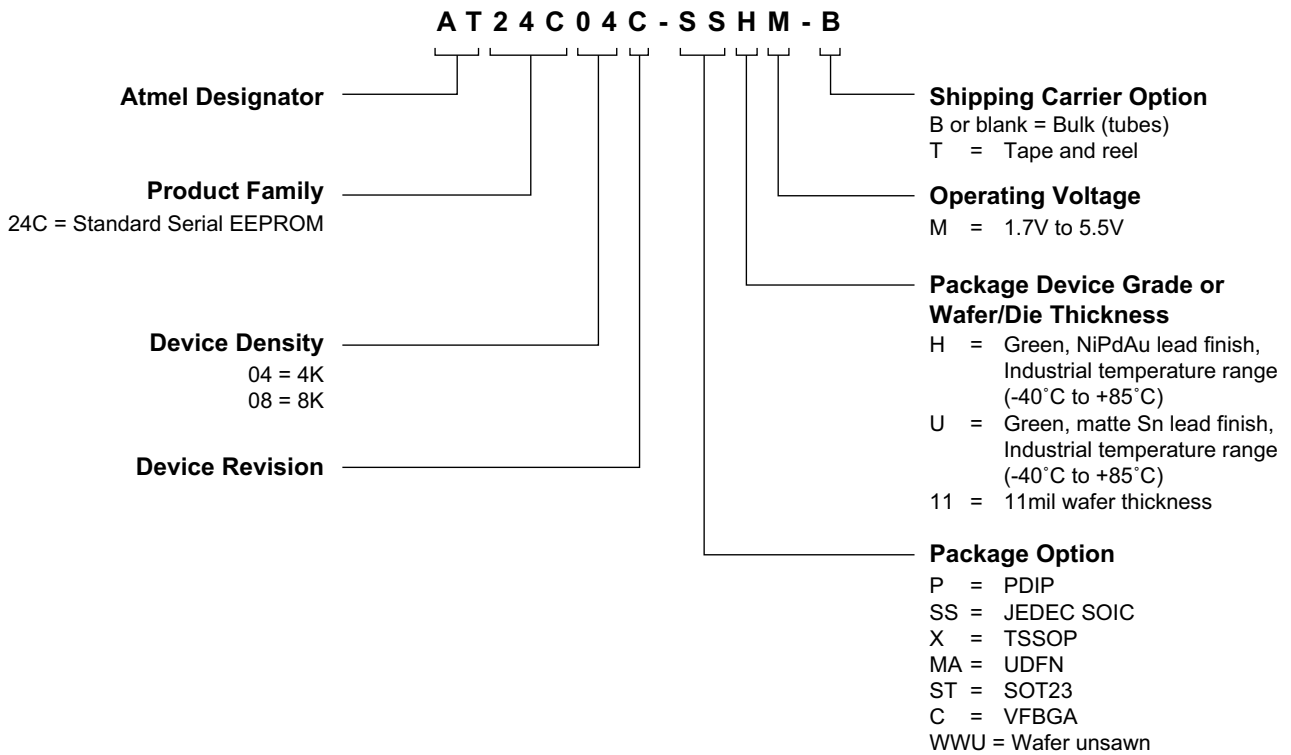

Figure 8-6. Sequential Read



9. Ordering Code Detail



10. Product Markings

AT24C04C and AT24C08C: Package Marking Information

<p>8-lead PDIP</p>	<p>8-lead SOIC</p>	<p>8-lead TSSOP</p>
<p>8-lead UDFN</p> <p>2.0 x 3.0 mm Body</p>	<p>5-lead SOT-23</p>	<p>8-ball VFBGA</p> <p>1.5 x 2.0 mm Body</p>

Note 1: ● designates pin 1

Note 2: Package drawings are not to scale

Catalog Number Truncation			
AT24C04C		Truncation Code ###: 04C	
AT24C08C		Truncation Code ###: 08C	
Date Codes			Voltages
Y = Year	M = Month	WW = Work Week of Assembly	M: 1.7V min
2: 2012	6: 2016	02: Week 2	
3: 2013	7: 2017	04: Week 4	
4: 2014	8: 2018	...	
5: 2015	9: 2019	52: Week 52	
Country of Assembly		Lot Number	Grade/Lead Finish Material
@ = Country of Assembly		AAA...A = Atmel Wafer Lot Number	U: Industrial/Matte Tin H: Industrial/NiPdAu
Trace Code			Atmel Truncation
XX = Trace Code (Atmel Lot Numbers Correspond to Code) Example: AA, AB.... YZ, ZZ			AT: Atmel ATM: Atmel ATML: Atmel

5/01/12

<p>Package Mark Contact: DL-CSO-Assy_eng@atmel.com</p>	TITLE	DRAWING NO.	REV.
	24C04-08CSM, AT24C04C and AT24C08C Package Marking Information	24C04-08CSM	B

11. Ordering Codes

11.1 Atmel AT24C04C Ordering Information

Ordering Code	Package	Voltage	Operation Range
AT24C04C-PUM (Bulk Form Only)	8P3	1.7V to 5.5V	Lead-free/Halogen-free/ Industrial Temperature (-40°C to 85°C)
AT24C04C-SSHM-B ⁽¹⁾ (NiPdAu Lead Finish)	8S1		
AT24C04C-SSHM-T ⁽²⁾ (NiPdAu Lead Finish)			
AT24C04C-XHM-B ⁽¹⁾ (NiPdAu Lead Finish)	8X		
AT24C04C-XHM-T ⁽²⁾ (NiPdAu Lead Finish)			
AT24C04C-MAHM-T ⁽²⁾ (NiPdAu Lead Finish)	8MA2		
AT24C04C-STUM-T ⁽²⁾	5TS1		
AT24C04C-CUM-T ⁽²⁾	8U3-1		
AT24C04C-WWU11M ⁽³⁾	Wafer Sale	1.7V to 5.5V	Industrial Temperature (-40°C to 85°C)

- Notes:
1. B = Bulk
 2. T = Tape and reel
 - SOIC = 4K per reel
 - TSSOP, UDFN, SOT23, and VFBGA = 5K per reel
 3. For Wafer sales, please contact Atmel Sales.

Package Type	
8P3	8-lead, 0.300" wide, Plastic Dual Inline (PDIP)
8S1	8-lead, 0.150" wide, Plastic Gull Wing Small Outline (JEDEC SOIC)
8X	8-lead, 4.4mm body, Plastic Thin Shrink Small Outline (TSSOP)
8MA2	8-pad, 2.00mm x 3.00mm body, 0.50mm pitch, Plastic Ultra Thin Dual Flat No Lead (UDFN)
5TS1	5-lead, 2.90mm x 1.60mm body, Plastic Thin Shrink Small Outline (SOT23)
8U3-1	8-ball, 1.50mm x 2.00mm body, 0.50mm pitch, Die Ball Grid Array (VFBGA)

11.2 Atmel AT24C08C Ordering Information

Ordering Code	Package	Voltage	Operation Range
AT24C08C-PUM (Bulk form only)	8P3	1.7V to 5.5V	Lead-free/Halogen-free/ Industrial Temperature (-40°C to 85°C)
AT24C08C-SSHM-B ⁽¹⁾ (NiPdAu Lead Finish)	8S1		
AT24C08C-SSHM-T ⁽²⁾ (NiPdAu Lead Finish)			
AT24C08C-XHM-B ⁽¹⁾ (NiPdAu Lead Finish)	8X		
AT24C08C-XHM-T ⁽²⁾ (NiPdAu Lead Finish)			
AT24C08C-MAHM-T ⁽²⁾ (NiPdAu Lead Finish)	8MA2		
AT24C08C-STUM-T ⁽²⁾	5TS1		
AT24C08C-CUM-T ⁽²⁾	8U3-1		
AT24C08C-WWU11M ⁽³⁾	Wafer Sale	1.7V to 5.5V	Industrial Temperature (-40°C to 85°C)

- Notes:
1. B = Bulk
 2. T = Tape and reel
 - SOIC = 4K per reel
 - TSSOP, UDFN, SOT23, and VFBGA = 5K per reel
 3. For Wafer sales, please contact Atmel Sales.

Package Type	
8P3	8-lead, 0.300" wide, Plastic Dual Inline (PDIP)
8S1	8-lead, 0.150" wide, Plastic Gull Wing Small Outline (JEDEC SOIC)
8X	8-lead, 4.4mm body, Plastic Thin Shrink Small Outline (TSSOP)
8MA2	8-pad, 2.00mm x 3.00mm body, 0.50mm pitch, Plastic Ultra Thin Dual Flat No Lead (UDFN)
5TS1	5-lead, 2.90mm x 1.60mm body, Plastic Thin Shrink Small Outline (SOT23)
8U3-1	8-ball, 1.50mm x 2.00mm body, 0.50mm pitch, Die Ball Grid Array (VFBGA)

12. Packaging Information

8P3 – PDIP

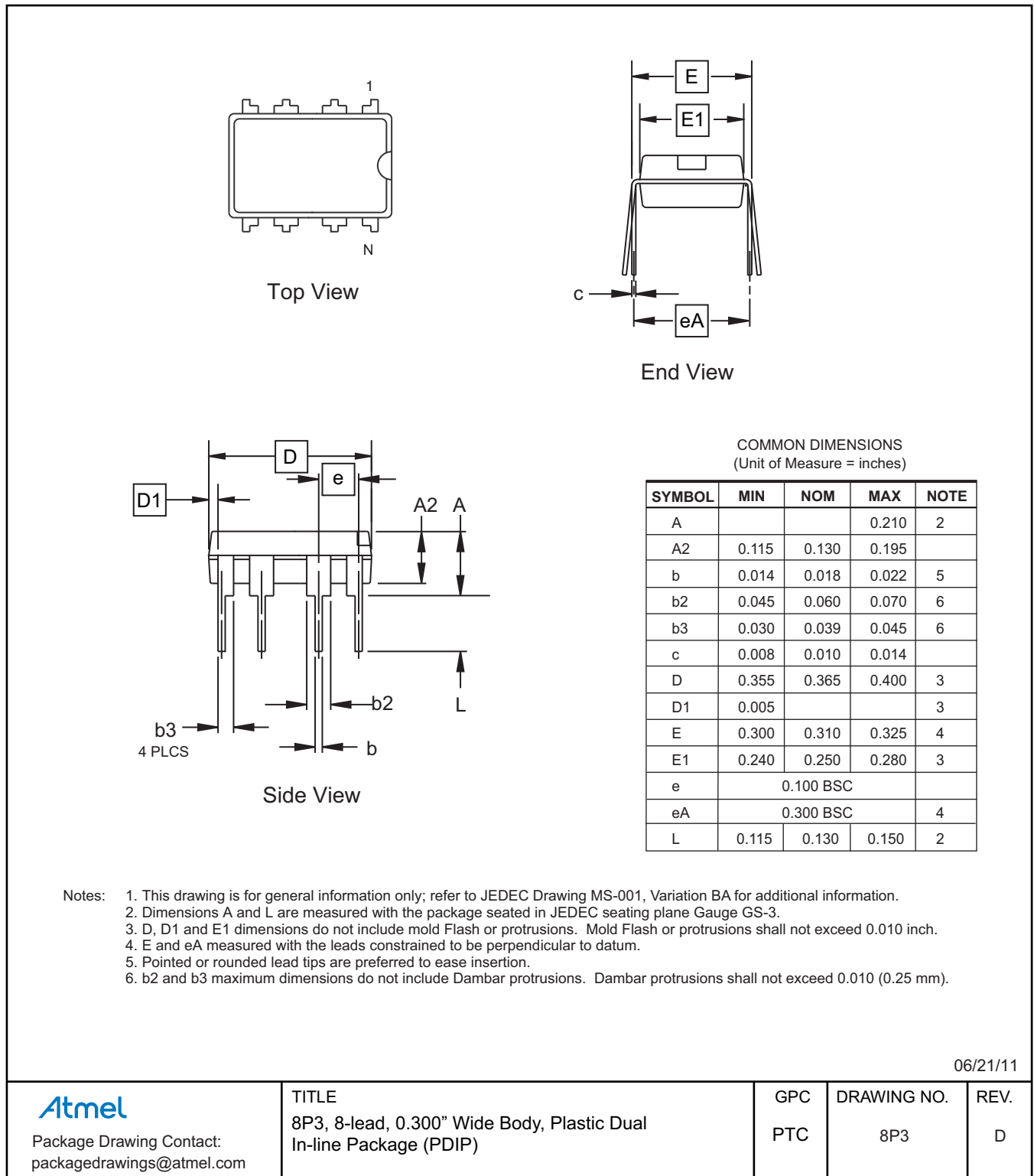

12.1 8S1 – JEDEC SOIC

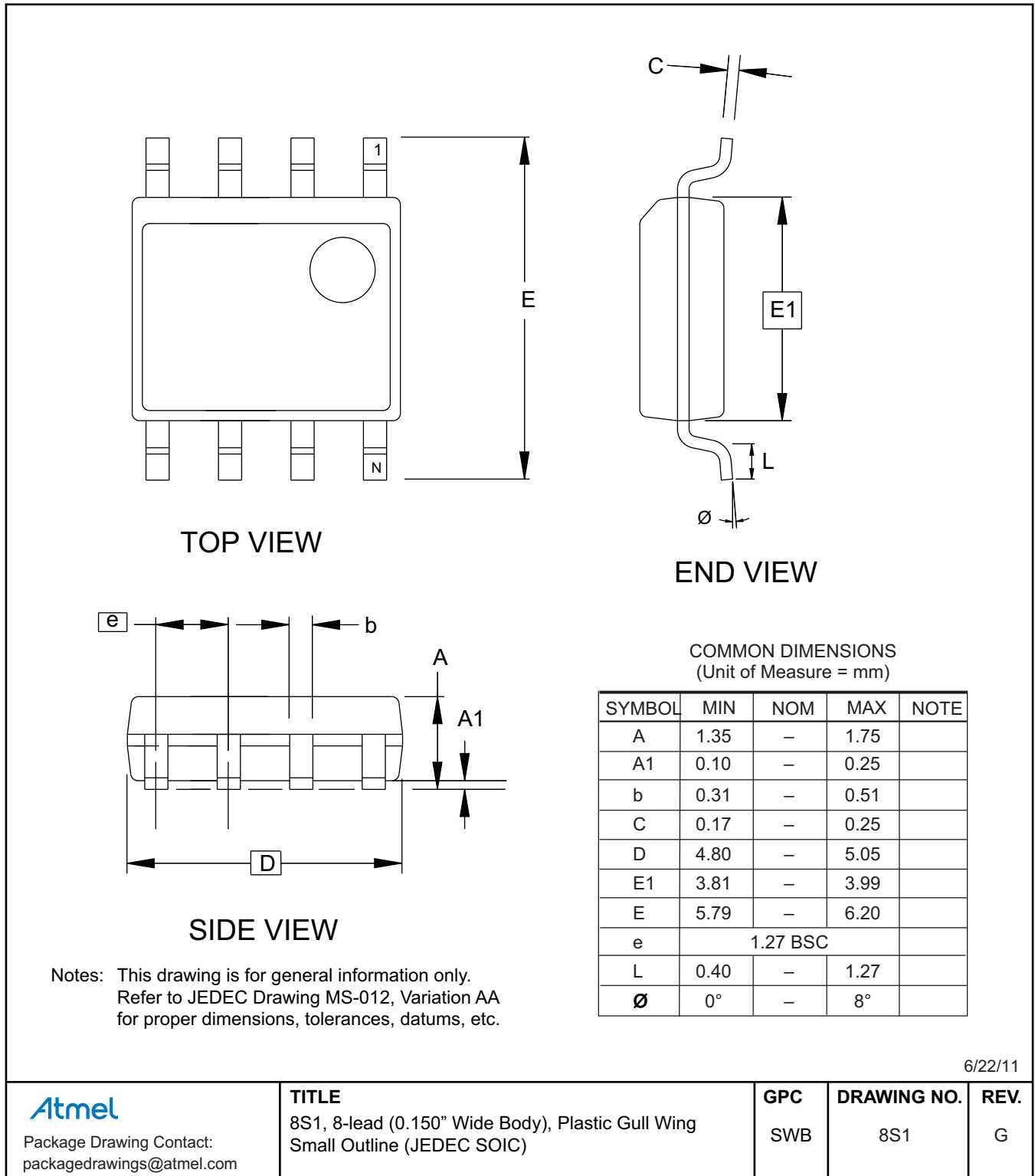

12.2 8X – TSSOP

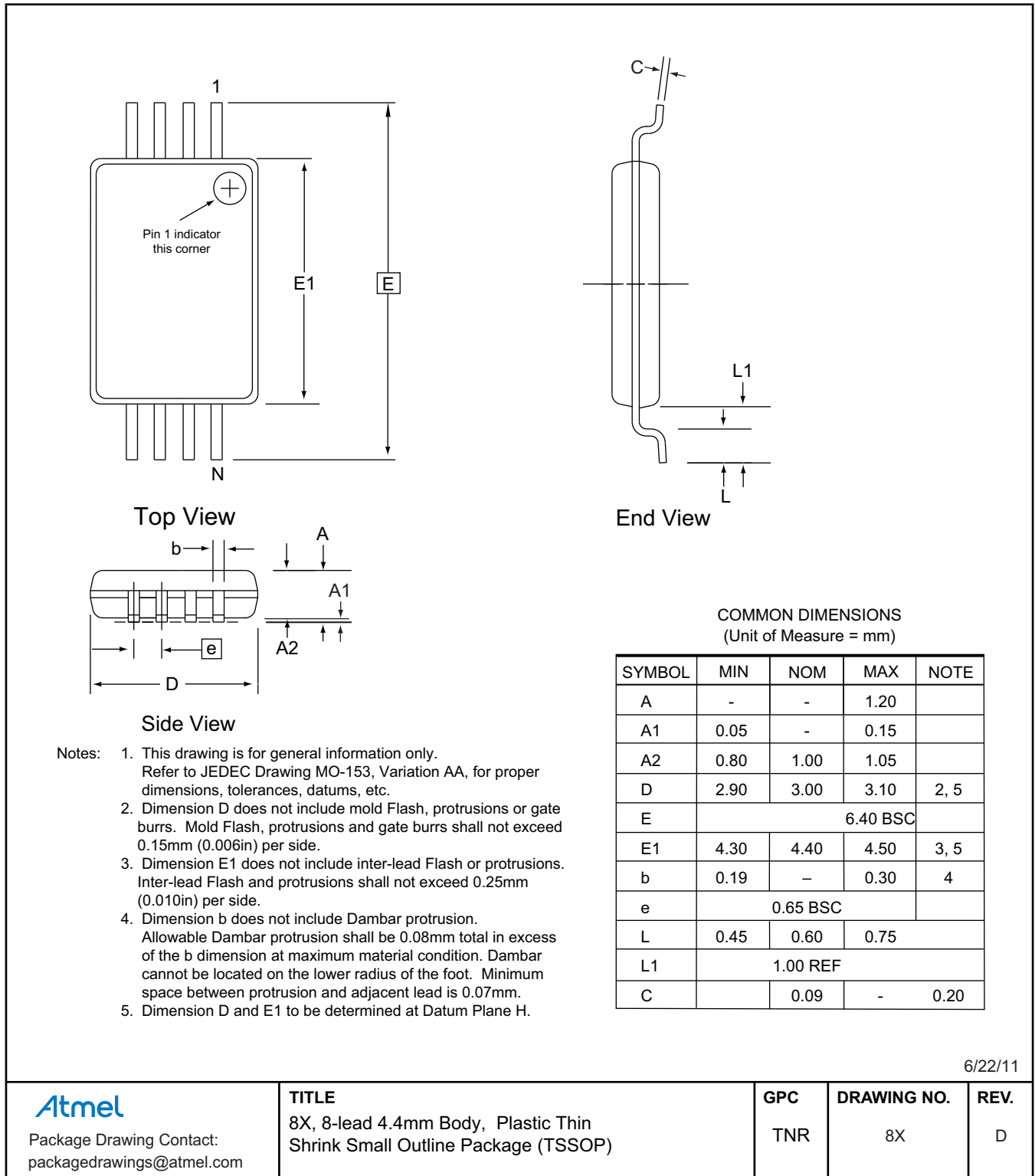

12.3 8MA2 - UDFN

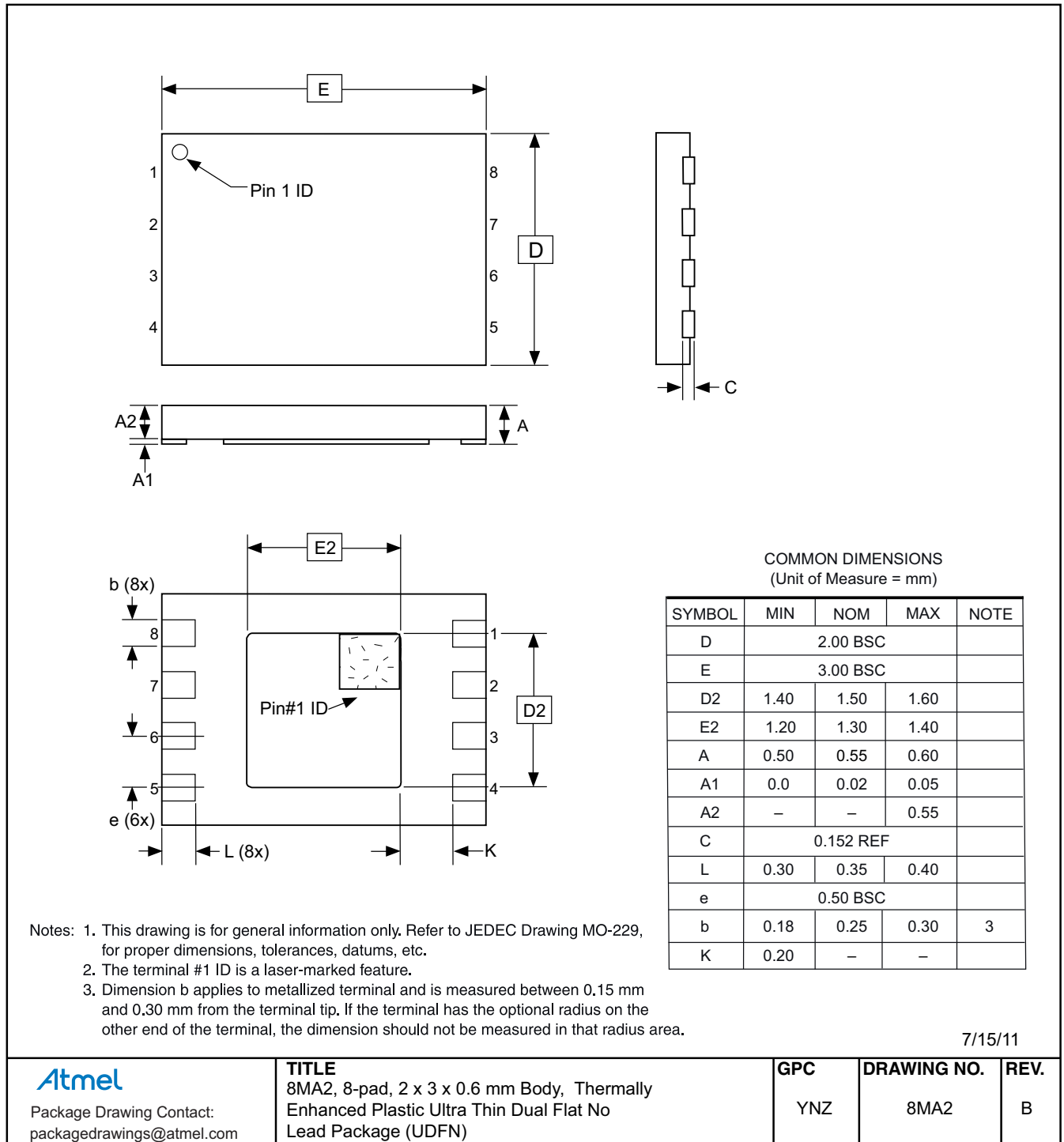

12.4 5TS1 – SOT23

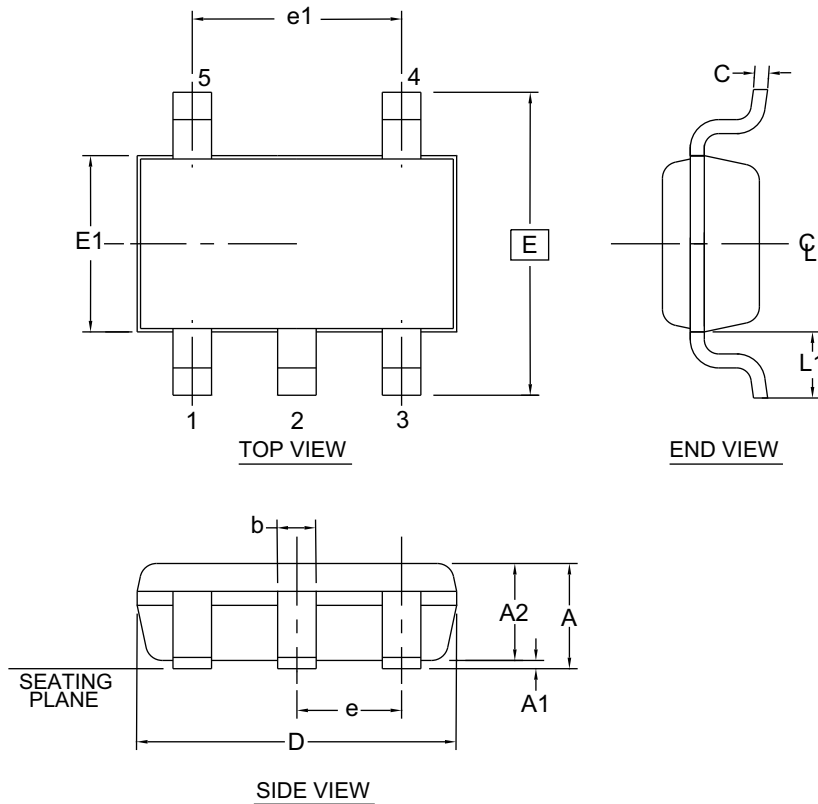

1. Dimension D does not include mold flash, protrusions or gate burrs. Mold flash, protrusions or gate burrs shall not exceed 0.15 mm per end. Dimension E1 does not include interlead flash or protrusion. Interlead flash or protrusion shall not exceed 0.15 mm per side.
2. The package top may be smaller than the package bottom. Dimensions D and E1 are determined at the outermost extremes of the plastic body exclusive of mold flash, tie bar burrs, gate burrs and interlead flash, but including any mismatch between the top and bottom of the plastic body.
3. These dimensions apply to the flat section of the lead between 0.08 mm and 0.15 mm from the lead tip.
4. Dimension "b" does not include dambar protrusion. Allowable dambar protrusion shall be 0.08 mm total in excess of the "b" dimension at maximum material condition. The dambar cannot be located on the lower radius of the foot. Minimum space between protrusion and an adjacent lead shall not be less than 0.07 mm.

This drawing is for general information only. Refer to JEDEC Drawing MO-193, Variation AB for additional information.

COMMON DIMENSIONS
(Unit of Measure = mm)

SYMBOL	MIN	NOM	MAX	NOTE
A	-	-	1.00	
A1	0.00	-	0.10	
A2	0.70	0.90	1.00	
c	0.08	-	0.20	3
D	2.90 BSC			1,2
E	2.80 BSC			1,2
E1	1.60 BSC			1,2
L1	0.60 REF			
e	0.95 BSC			
e1	1.90 BSC			
b	0.30	-	0.50	3,4

5/31/12

Atmel

Package Drawing Contact:
packagedrawings@atmel.com

TITLE

5TS1, 5-lead 1.60mm Body, Plastic Thin
Shrink Small Outline Package (Shrink SOT)

GPC

TSZ

DRAWING NO.

5TS1

REV.

D

12.5 8U3-1 – VFBGA

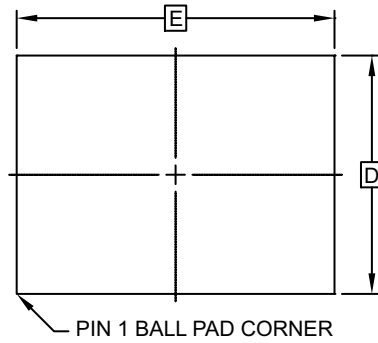

TOP VIEW

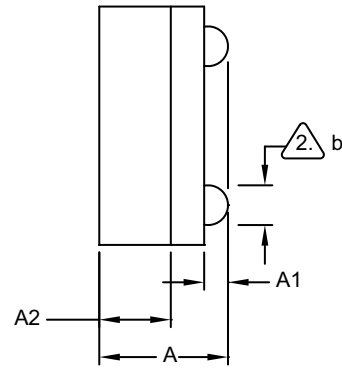

SIDE VIEW

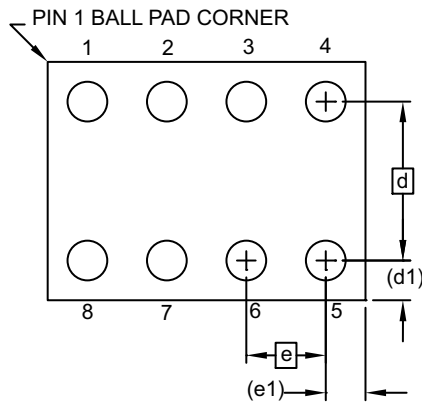

BOTTOM VIEW
8 SOLDER BALLS

Notes:

1. This drawing is for general information only.
2. Dimension 'b' is measured at maximum solder ball diameter.
3. Solder ball composition shall be 95.5Sn-4.0Ag-.5Cu.

COMMON DIMENSIONS
(Unit of Measure - mm)

SYMBOL	MIN	NOM	MAX	NOTE
A	0.73	0.79	0.85	
A1	0.09	0.14	0.19	
A2	0.40	0.45	0.50	
b	0.20	0.25	0.30	2
D	1.50 BSC			
E	2.0 BSC			
e	0.50 BSC			
e1	0.25 REF			
d	1.00 BSC			
d1	0.25 REF			

3/27/12

Atmel

Package Drawing Contact:
packagedrawings@atmel.com

TITLE
8U3-1, 8-ball, 1.50mm x 2.00mm body,
0.50mm pitch, VFBGA Package

GPC
GXU

DRAWING NO.
8U3-1

REV.
E

13. Revision History

Doc. Rev.	Date	Comments
8787C	07/2012	Correct ordering codes: - AT24C04C-WWU11, Die Sale to AT24C04C-WWU11M, Wafer Sale. - AT24C08C-WWU11, Die Sale to AT24C08C-WWU11M, Wafer Sale. Remove WDT from ordering code detail. Update Atmel logos and disclaimer page.
8787B	05/2012	Remove preliminary status. Remove A ₀ signal from the block diagram. I _{SB2} parameter measured at 5.5V. In AC Characteristics table, changed 1.7V, 2.5V, 2.7V to 1.7 and 5.0V to 2.5V, 2.7V, 5.0V. Increase t _i maximum value from 50ns to 100ns. Endurance parameter is studied at 3.3V, to +25°C, Page mode. Remove Serial Number Read from read operations. Update product markings. Update 8X and 8U3-1 package drawings. Update template.
8787A	10/2011	Initial document release.



Enabling Unlimited Possibilities®

Atmel Corporation

1600 Technology Drive
San Jose, CA 95110
USA

Tel: (+1) (408) 441-0311

Fax: (+1) (408) 487-2600

www.atmel.com

Atmel Asia Limited

Unit 01-5 & 16, 19F
BEA Tower, Millennium City 5
418 Kwun Tong Roa
Kwun Tong, Kowloon
HONG KONG

Tel: (+852) 2245-6100

Fax: (+852) 2722-1369

Atmel Munich GmbH

Business Campus
Parkring 4
D-85748 Garching b. Munich
GERMANY

Tel: (+49) 89-31970-0

Fax: (+49) 89-3194621

Atmel Japan G.K.

16F Shin-Osaki Kangyo Bldg
1-6-4 Osaki, Shinagawa-ku
Tokyo 141-0032
JAPAN

Tel: (+81) (3) 6417-0300

Fax: (+81) (3) 6417-0370

© 2012 Atmel Corporation. All rights reserved. / Rev.: 8787C-SEEPR-7/12

Atmel®, Atmel logo and combinations thereof, RapidS™, Enabling Unlimited Possibilities®, and others are registered trademarks or trademarks of Atmel Corporation or its subsidiaries. Other terms and product names may be trademarks of others.

Disclaimer: The information in this document is provided in connection with Atmel products. No license, express or implied, by estoppel or otherwise, to any intellectual property right is granted by this document or in connection with the sale of Atmel products. EXCEPT AS SET FORTH IN THE ATMEL TERMS AND CONDITIONS OF SALES LOCATED ON THE ATMEL WEBSITE, ATMEL ASSUMES NO LIABILITY WHATSOEVER AND DISCLAIMS ANY EXPRESS, IMPLIED OR STATUTORY WARRANTY RELATING TO ITS PRODUCTS INCLUDING, BUT NOT LIMITED TO, THE IMPLIED WARRANTY OF MERCHANTABILITY, FITNESS FOR A PARTICULAR PURPOSE, OR NON-INFRINGEMENT. IN NO EVENT SHALL ATMEL BE LIABLE FOR ANY DIRECT, INDIRECT, CONSEQUENTIAL, PUNITIVE, SPECIAL OR INCIDENTAL DAMAGES (INCLUDING, WITHOUT LIMITATION, DAMAGES FOR LOSS AND PROFITS, BUSINESS INTERRUPTION, OR LOSS OF INFORMATION) ARISING OUT OF THE USE OR INABILITY TO USE THIS DOCUMENT, EVEN IF ATMEL HAS BEEN ADVISED OF THE POSSIBILITY OF SUCH DAMAGES. Atmel makes no representations or warranties with respect to the accuracy or completeness of the contents of this document and reserves the right to make changes to specifications and products descriptions at any time without notice. Atmel does not make any commitment to update the information contained herein. Unless specifically provided otherwise, Atmel products are not suitable for, and shall not be used in, automotive applications. Atmel products are not intended, authorized, or warranted for use as components in applications intended to support or sustain life.