



MAX5183 Evaluation Kit

General Description

The MAX5183 evaluation kit (EV kit) is designed to simplify evaluation of the 8-bit and 10-bit, dual, 40MHz, simultaneous-update or alternate-phase-update MAX5180/MAX5183, MAX5182/MAX5185, MAX5186/MAX5189, and MAX5188/MAX5191 digital-to-analog converters (DACs). The board contains all circuitry necessary for evaluating the dynamic performance of these high-speed converters, including a circuit to convert the DAC's differential outputs into single-ended outputs. Since the design combines high-speed analog and digital circuitry, the board layout calls for special precautions and design features.

Connector pads for power supplies (AVDD, DVDD, VCC, and VEE), DAC outputs (VOUT1, VOUT1A, VOUT2, and VOUT2A), and SMA connectors for the digital and control inputs (D0–D9, CS, CLK) simplify connection to the EV kit. The four-layer board layout is optimized for best dynamic performance.

The MAX5183 dual, 10-bit, 40MHz, simultaneous-update DAC is installed on the EV kit board. The kit can be used to evaluate the MAX5180, MAX5182, MAX5185, MAX5186, MAX5188, MAX5189, or MAX5191 with minor component changes.

Features

- ◆ **Fast Evaluation and Performance Testing**
- ◆ **SMA Coaxial Connectors for Clock and Data Inputs**
- ◆ **Performance-Optimized Four-Layer PC Board with Separate Analog and Digital Power and Ground Connections**
- ◆ **On-Board Differential to Single-Ended Conversion Circuitry**
- ◆ **Fully Assembled and Tested with MAX5183BEEI**

Ordering Information

PART	TEMP RANGE	IC PACKAGE
MAX5183EVKIT	0°C to +70°C	28 QSOP

Component List

DESIGNATION	QTY	DESCRIPTION
C1, C2, C11, C12	4	10 μ F \pm 10%, 10V tantalum capacitors (A) AVX TAJA106K010R or Kemet T494A106K010AS
C3–C6, C9, C10, C13, C14, C19	9	0.1 μ F \pm 10%, 25V X7R ceramic capacitors (0603) TDK C1608X7R1E104KT
C7, C8, C15–C18	6	0.01 μ F \pm 10%, 50V X7R ceramic capacitors (0603) TDK C1608X7R1H103KT or Taiyo Yuden UMK107B103KZ
R1–R12	12	49.9 Ω \pm 1% resistors (0805)
R13–R24	0	Not installed (0805)
R25–R28, R37	0	Not installed (0603)
R29–R36	8	402 Ω \pm 1% resistors (0603)

DESIGNATION	QTY	DESCRIPTION
L1	1	Ferrite bead (1206) Panasonic EXC-CL3216U1
T1, T2	2	Transformers (1:8) Mini-Circuits ADT8-1T
U1	1	MAX5183BEEI (28-pin QSOP)
U2, U3	2	MAX4108ESA (8-pin SO)
D0–D9, CLK, CS, VOUT1, VOUT1A, VOUT2, VOUT2A	16	SMA PC mount vertical connectors
JU1–JU12	12	2-pin headers
JU13–JU19	7	3-pin headers
None	8	Shunts (JU11, JU13–JU19)
None	1	MAX5183 EV kit PC board

Evaluates: MAX5180/82/83/85/86/88/89/91



MAX5183 Evaluation Kit

Quick Reference

The EV kit is delivered fully assembled, tested, and sealed in an antistatic bag. To ensure proper operation, open the antistatic bag only at a static-safe work area and follow the instructions listed below. **Do not turn on the power supplies until all power connections to the EV kit are established.** Figure 1 shows a typical evaluation setup for single-ended output operation:

- 1) Connect a **-5V** power supply to the pad marked **VEE**. Connect the supply's ground to the AGND pad. This negative supply for the MAX4108 amplifiers may also be connected to ground for single-supply operation.
- 2) Connect a **3V** power supply to the pad marked **AVDD**. Connect the supply's ground to the pad marked AGND.
- 3) Connect a **5V** power supply to the pad marked **VCC**. Connect the supply's ground to the pad marked AGND.
- 4) Connect a **3V** power supply to the pad marked **DVDD**. Connect the supply's ground to the pad marked DGND.
- 5) Verify that a shunt is connected across jumper JU11 (chip select).
- 6) Connect a word or pattern generator (e.g., Tektronix/Sony DG2020A) with the 10-bit digitized pattern of a sinusoidal input signal to the SMA connectors labeled D0–D9.
- 7) Connect an appropriate low-phase-noise clock signal generator (e.g., HP 8662A) to the CLK SMA connector.
- 8) Verify that shunts are connected across pins 2 and 3 of jumpers JU16, JU17, JU18, and JU19.
- 9) Connect an oscilloscope or a spectrum analyzer (e.g., HP 8560E) to the VOUT1A and VOUT2A SMA connectors to analyze the output waveforms.
- 10) Ensure jumpers JU13, JU14, JU15 are configured to the default settings as shown in Tables 1, 2.
- 11) Turn on the supplies and signal sources.

Detailed Description

Digital Inputs

The MAX5183 EV kit board includes high-frequency SMA connectors and 2-pin headers JU1–JU12 for the digital data, clock, and control-line inputs (D0–D9, \overline{CS} , CLK). Each of these matched-impedance signal lines provides on-board series 50 Ω termination resistors

located in the signal path of the digital inputs to DGND. Optionally, 50 Ω termination resistors to DGND may be installed by the user.

DAC Differential Outputs

The MAX5180/MAX5182/MAX5186/MAX5188 current-output DACs are designed to supply full-scale output currents of 1mA into 400 Ω loads, in parallel with a capacitive load of 5pF. The MAX5183/MAX5185/MAX5189/MAX5191 voltage-output DACs have on-chip 400 Ω resistors that restore the array currents to proportional, differential voltages of ± 400 mV full scale. These differential output voltages are then used to drive a transformer or a low-distortion, high-speed operational amplifier (such as the MAX4108 devices and transformers supplied in the EV kit, Figure 2) to convert the differential voltage into a single-ended voltage.

The single-ended outputs may be derived from amplifiers outputs VOUT1A and VOUT2A or from transformers outputs VOUT1 and VOUT2 (Tables 3, 4).

The MAX5183 EV kit is shipped with the necessary external circuitry to operate the installed MAX5183 voltage-output DAC. The full-scale output current-set resistor (R37) and the 402 Ω conversion resistors (R25–R28) are not required for any of the voltage-output DACs and are therefore not installed on the MAX5183 EV kit.

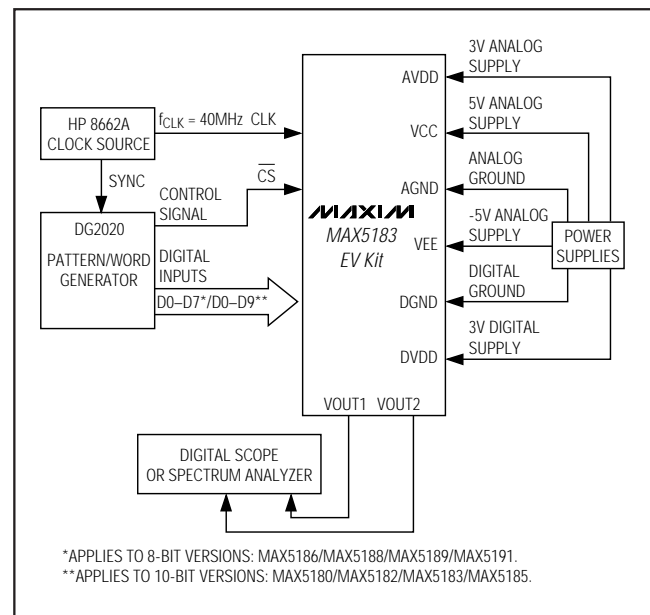

Figure 1. Typical EV Kit Test Setup for Single-Ended Operation

MAX5183 Evaluation Kit

Evaluates: MAX5180/82/83/85/86/88/89/91

DAC Reference Options

The MAX5183 family features an on-chip 1.2V precision bandgap reference, which can be activated by connecting the reference enable pin $\overline{\text{REN}}$ to DGND. For this purpose, jumper JU15 must remain in location 2-3 (Table 1), which is the default location used when the board is shipped.

To disable the internal reference, connect $\overline{\text{REN}}$ to DVDD by placing jumper JU15 in location 1-2. A temperature-stable external reference may now be applied at the REFO pad to set the full-scale current/voltage output.

Standby Mode

To place the DAC in standby mode (Table 2), connect digital inputs PD and DACEN to DGND by setting jumpers JU13 and JU14 to locations 2-3. In standby, both the reference and the control amplifier are active, with the current array inactive. To exit this condition, pull DACEN high with PD held at DGND by leaving jumper JU14 in location 2-3 and changing jumper JU13 to location 1-2.

Shutdown Mode

For lowest power consumption, the MAX5183 EV kit provides a shutdown mode (Table 2) in which the reference, control amplifier, and current array are inactive and the converter's supply current is reduced to 1 μ A. To enter this mode, connect PD to DVDD by changing jumper JU14 to location 1-2. To return to active mode, connect PD to DGND by changing jumper JU14 to location 2-3, and connect DACEN to DVDD by changing jumper JU13 to location 1-2.

Power Supplies

The EV kit features separate analog (AVDD) and digital (DVDD) power and ground connections for best dynamic performance. A 2.7V to 3.3V source connected to AVDD and DVDD is required for normal operation. It is not necessary to connect the analog and digital grounds together externally. The two grounds are connected together at a single point on the MAX5183 EV kit (at ferrite bead L1). An additional ± 5 V source is required when using the differential to single-ended operational amplifier conversion circuitry. Connect the +5V terminal to the VCC pad and the -5V terminal to the VEE pad. Connect the ground terminal to the AGND pad.

Evaluating the MAX518x Family

The MAX5183 EV kit may be used to evaluate other MAX518x family 8-bit and 10-bit dual DACs. The changes required for this are listed in Table 5.

When evaluating the MAX5186/MAX5189 (dual, 8-bit DACs with simultaneous update) and the MAX5188/MAX5191 (dual, 8-bit DACs with alternate-phase update), input data bits D0 and D1 must be connected to DGND to ensure proper operation. Install shunts on jumpers JU1 and JU2 to connect D0 and D1 to GND.

Table 1. Selecting Reference Mode

$\overline{\text{REN}}$ JUMPER (JU15) POSITION	REFERENCE MODE
1-2	Connect external precision reference at REFO.
2-3*	Internal 1.2V bandgap reference active

*Indicates default jumper state

Table 2. Selecting Operating Mode

PD JUMPER (JU14) POSITION	DACEN JUMPER (JU13) POSITION	OPERATING MODE
1-2	X	Shutdown
2-3	2-3	Standby
2-3*	1-2*	Normal operation

X = Don't care

*Indicates default jumper state

Table 3. Single-Ended Signal for DAC1 Selection

JU16 POSITION	JU17 POSITION	EV KIT FUNCTION
1-2	1-2	DAC1 differential output converted to single-ended signal using transformer configuration available at VOUT1 SMA connector
2-3	2-3	DAC1 differential output converted to single-ended signal using operational amplifier configuration available at VOUT1A SMA connector

Table 4. Single-Ended Signal for DAC2 Selection

JU18 POSITION	JU19 POSITION	EV KIT FUNCTION
1-2	1-2	DAC2 differential output converted to single-ended signal using transformer configuration available at VOUT2 SMA connector
2-3	2-3	DAC2 differential output converted to single-ended signal using operational amplifier configuration available at VOUT2A SMA connector

MAX5183 Evaluation Kit

Board Layout

The EV kit is a 4-layer board design (Table 6), optimized for high-speed signals. The EV kit board uses FR4 epoxy dielectric material with a relative dielectric constant of $\epsilon_r = 4.2$ to 4.9. A proper FR4 design requires 14mils foil thickness for each 1oz copper layer and 0.1mm dielectric thickness between the layers. All high-speed signals are routed through 50Ω impedance-matched transmission lines. The line width for these signal lines is 14mils, with a ground plane height of 8mils.

The board layout separates the analog and digital portions of the circuit. Matched 50Ω impedance transmission lines are used for all high-speed digital inputs. The digital inputs are arranged in a half circle to match the line lengths between DAC inputs and the pattern and clock generators' SMA connectors. The lengths of these 50Ω transmission lines are matched to within 50mils to minimize layout-dependent data skew.

Wherever large ground planes are used, care is taken to ensure that the analog planes do not overlap with any digital planes. This eliminates the possibility of capacitively coupling digital noise through the circuit board to sensitive analog areas.

Table 5. Evaluating All Dual, 8-Bit/10-Bit DACs in the MAX518x Family

DEVICE INSTALLED ON THE EV KIT	R25–R28, R37
MAX5180	Installed
MAX5182	Installed
MAX5183*	Not installed
MAX5185	Not installed
MAX5186	Installed
MAX5188	Installed
MAX5189	Not installed
MAX5191	Not installed

*As shipped

Table 6. EV Kit PC Board Layers

LAYER	DESCRIPTION
Layer I, top	Components, jumpers, SMA connectors, digital 50Ω microstrip lines, 50Ω termination resistors, DVDD, VCC
Layer II, analog and digital ground plane	Analog (AGND) and digital (DGND) ground
Layer III, analog and digital power plane	Analog (AVDD) and digital (DVDD) power
Layer IV, bottom	Components, 50Ω termination resistors, AVDD, VEE

Component Suppliers

SUPPLIER	PHONE	FAX	WEBSITE
AVX	843-946-0238	843-626-3123	www.avxcorp.com
Kemet	864-963-6300	864-963-6322	www.kemet.com
Panasonic	714-373-7366	714-737-7323	www.panasonic.com
Taiyo Yuden	800-348-2496	847-925-0899	www.t-yuden.com
TDK	847-803-6100	847-390-4405	www.component.tdk.com

Note: Please indicate that you are using the MAX5183 when contacting these component suppliers.

MAX5183 Evaluation Kit

Evaluates: MAX5180/82/83/85/86/88/89/91

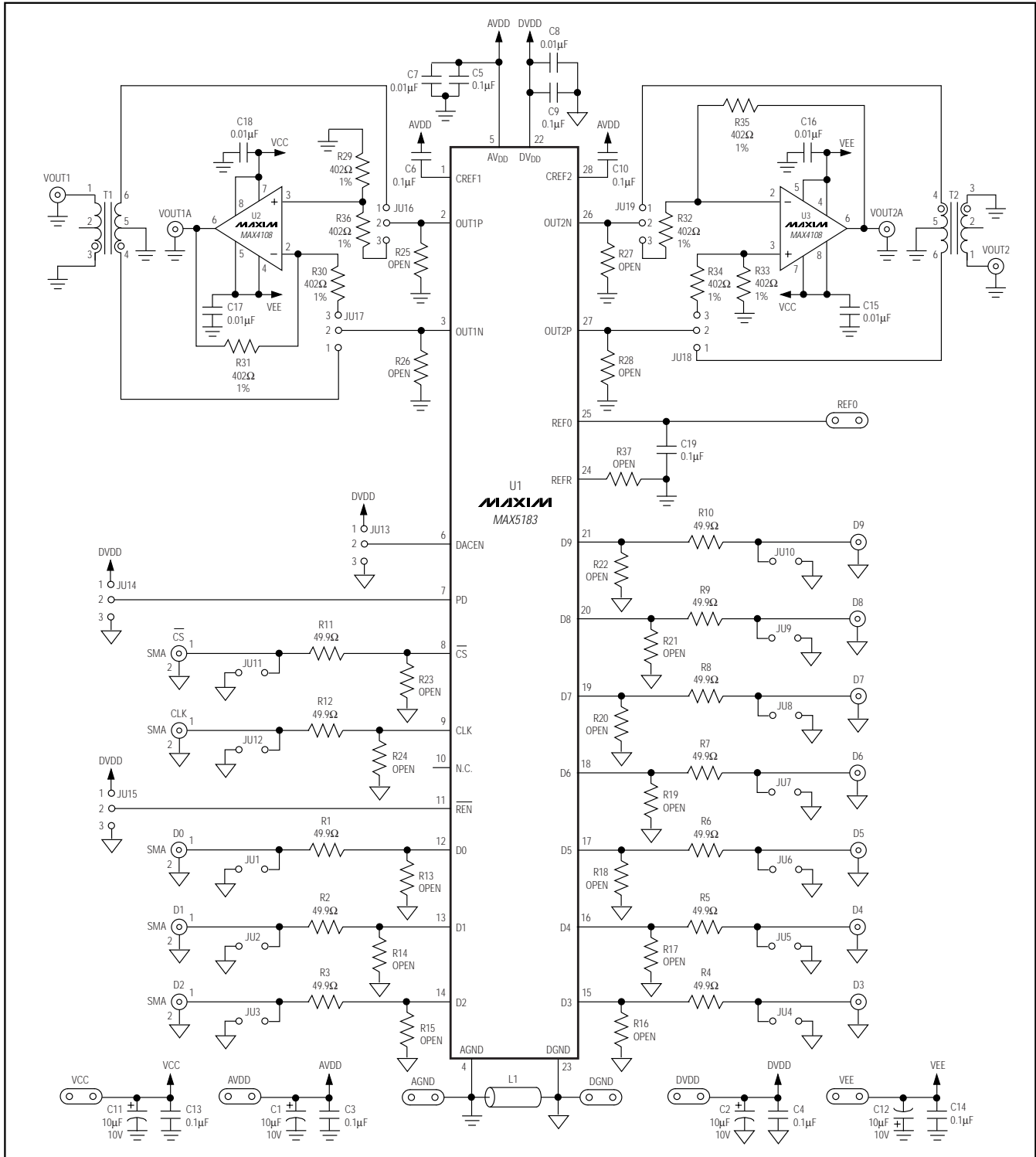

Figure 2. MAX5183 EV Kit Schematic

MAX5183 Evaluation Kit

Evaluates: MAX5180/82/83/85/86/88/89/91

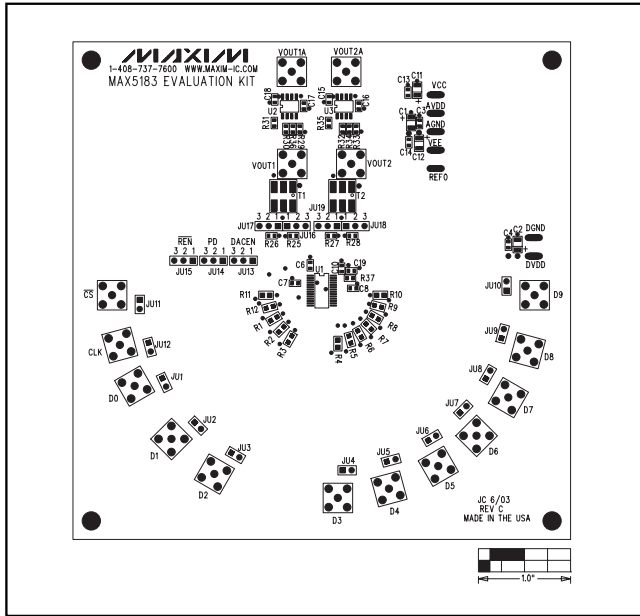

Figure 3. MAX5183 EV Kit Component Placement Guide—Component Side

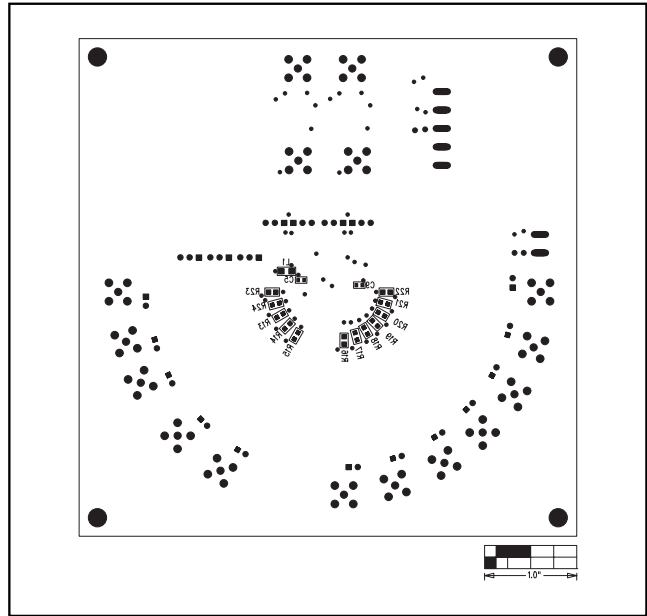

Figure 4. MAX5183 EV Kit Component Placement Guide—Solder Side

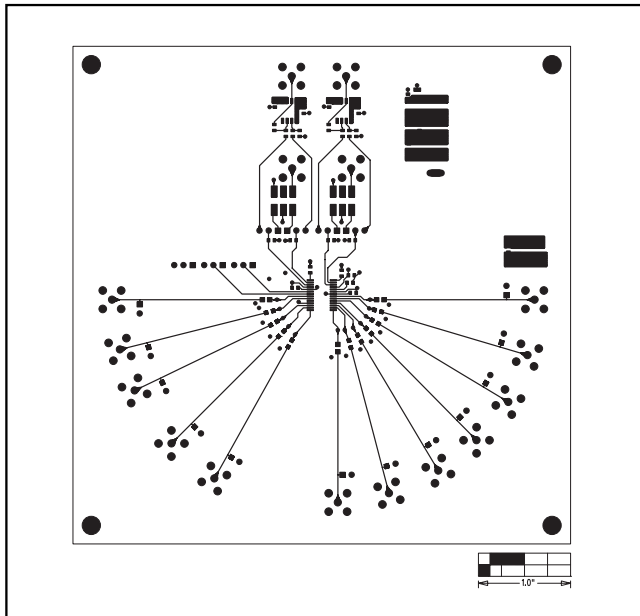

Figure 5. MAX5183 EV Kit PC Board Layout—Component Side (Layer I)

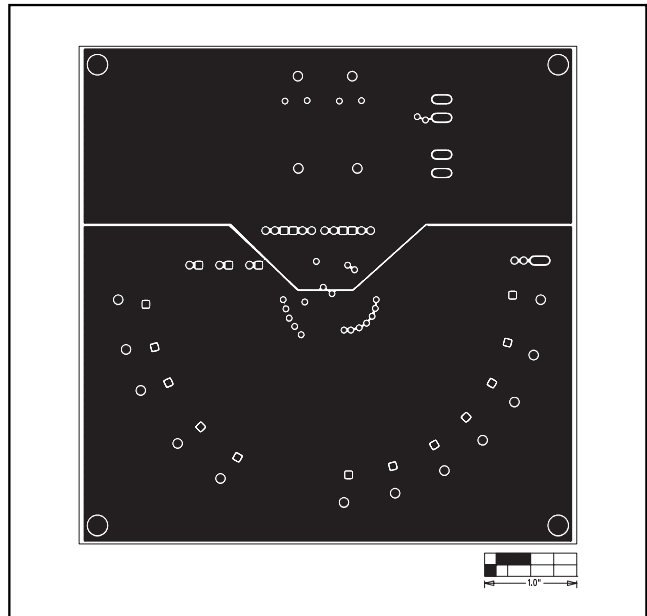

Figure 6. MAX5183 EV Kit PC Board Layout—Ground Planes (Layer II)

MAX5183 Evaluation Kit

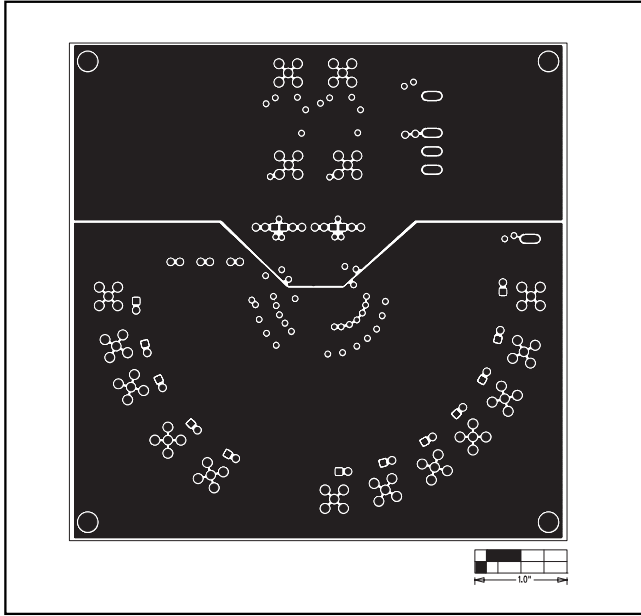

Figure 7. MAX5183 EV Kit PC Board Layout—Power Planes (Layer III)

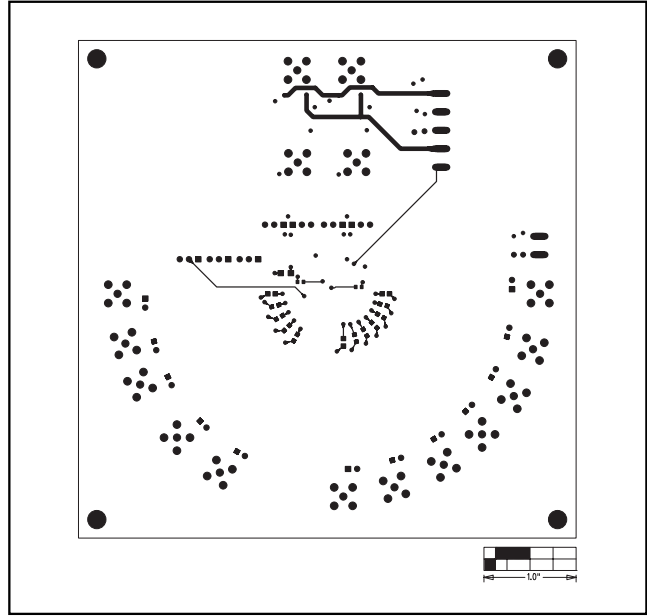

Figure 8. MAX5183 EV Kit PC Board Layout—Solder Side (Layer IV)

Evaluates: MAX5180/82/83/85/86/88/89/91

Maxim cannot assume responsibility for use of any circuitry other than circuitry entirely embodied in a Maxim product. No circuit patent licenses are implied. Maxim reserves the right to change the circuitry and specifications without notice at any time.

Maxim Integrated Products, 120 San Gabriel Drive, Sunnyvale, CA 94086 408-737-7600 _____ 7

© 2003 Maxim Integrated Products

Printed USA

MAXIM is a registered trademark of Maxim Integrated Products.