



MAX5873/MAX5874/MAX5875 Evaluation Kits

General Description

The MAX5873/MAX5874/MAX5875 evaluation kits (EV kits) are fully assembled and tested circuit boards that contain all the components necessary to evaluate the performance of the MAX5873 (12-bit), MAX5874 (14-bit), and MAX5875 (16-bit) dual digital-to-analog converters (DACs). The 200MSPS DACs integrate a 1.20V voltage reference and provide a differential current output. The EV kits operate with parallel CMOS-compatible digital data inputs, a single-ended clock input, and require a 3.3V/1.8V dual-output power supply for simple board operation. Each EV kit also contains an external 1.25V reference voltage that can be used to drive the input reference voltage pin of the DAC.

Part Selection Table

PART NUMBER	BITS	SPEED (MSPS)
MAX5873EGK+D	12	200
MAX5874EGK+D	14	200
MAX5875EGK+D	16	200

Features

- ◆ Fast Evaluation and Performance Testing
- ◆ CMOS-Compatible Inputs
- ◆ SMA Coaxial Connectors for Clock Input and Analog Outputs
- ◆ On-Board External 1.25V Reference Voltage
- ◆ 50Ω Matched Clock Input and Analog Output Signal Lines
- ◆ Single-Ended-to-Differential Clock Signal Conversion Circuitry
- ◆ Differential Current to Single-Ended Voltage Output Conversion Circuitry
- ◆ Full-Scale Current Output Configured for 20mA
- ◆ Fully Assembled and Tested

Ordering Information

PART	TEMP RANGE*	IC PACKAGE
MAX5873EVKIT	0°C to +70°C	68 QFN-EP†
MAX5874EVKIT	0°C to +70°C	68 QFN-EP†
MAX5875EVKIT	0°C to +70°C	68 QFN-EP†

*EV kit PC board temperature range only.

†EP = Exposed paddle.

Common Component List

DESIGNATION	QTY	DESCRIPTION
C1, C2, C4–C14, C37	14	0.1μF ±10%, 10V X5R ceramic capacitors (0402) TDK C1005X5R1A104K or Taiyo Yuden LMK105BJ104KV
C3	1	1μF ±10%, 6.3V X5R ceramic capacitor (0402) TDK C1005X5R0J105K
C15–C19	5	1μF ±10%, 10V X5R ceramic capacitors (0603) TDK C1608X5R1A105K
C20–C24	5	10μF ±10%, 10V tantalum capacitors (A) AVX TAJA106K010R or Kemet T494A106K010AS
C25–C29	5	47μF ±10%, 6.3V tantalum capacitors (B) AVX TAJB476K006R or Kemet T494B476K006AS

DESIGNATION	QTY	DESCRIPTION
C30–C36	0	Not installed, ceramic capacitors (0603)
CLK, OUTPUTI, OUTPUTQ	3	SMA PC-mount vertical connectors
J1, J2	2	2 x 20-pin surface-mount headers (0.1in)
JU1, JU2, JU3	3	3-pin headers
JU4, JU5	2	2-pin headers
L1–L5	5	Ferrite bead cores (0805) Fair-Rite 2508051217Z0
OUTIP, OUTIN, OUTQP, OUTQN	0	Not installed, SMA connectors
R1, R2, R4, R5	4	49.9Ω ±0.1% resistors (0603) IRC PFC-W0603R-03-49R9-B
R3, R6	2	100Ω ±1% resistors (0603)
R7	1	2kΩ ±1% resistor (0603)
R8, R9	2	24.9Ω ±1% resistors (0603)



For pricing, delivery, and ordering information, please contact Maxim/Dallas Direct! at 1-888-629-4642, or visit Maxim's website at www.maxim-ic.com.

MAX5873/MAX5874/MAX5875 Evaluation Kits

DESIGNATION	QTY	DESCRIPTION
R10–R47	0	Not installed, resistors (0603)
T1, T2, T3	3	1:1 RF transformers Mini-Circuits ADTL1-12
T4, T5	2	1:1 RF transformers Coilcraft TTWB3010-1
U1	1	See the <i>EV Kit Specific Component List</i>

EV Kit Specific Component List

EV KIT PART NUMBER	DESIGNATION	DESCRIPTION
MAX5873EVKIT	U1	MAX5873EGK (68-pin QFN-EP, 10mm x 10mm x 0.9mm)
MAX5874EVKIT		MAX5874EGK (68-pin QFN-EP, 10mm x 10mm x 0.9mm)
MAX5875EVKIT		MAX5875EGK (68-pin QFN-EP, 10mm x 10mm x 0.9mm)

Quick Start

Recommended Equipment

- Three 3.3V, 100mA DC power supplies
- Two 1.8V, 100mA DC power supplies
- Two signal generators with low phase noise and low jitter for clock inputs (e.g., Agilent 8644B)
- A dual, 12-bit (MAX5873), 14-bit (MAX5874), or 16-bit (MAX5875) digital pattern generator for data inputs (e.g., DG2020A)
- Spectrum analyzer (e.g., Rohde & Schwartz FSU)
- Voltmeter

The EV kit is a fully assembled and tested surface-mount board. Follow the steps below for board operation. **Do not turn on power supplies or enable signal generators until all connections are completed (Figure 1).**

- 1) Verify that a shunt is installed across pins 1 and 2 of jumper JU1 (dual-port input enabled).
- 2) Verify that shunts are installed across pins 2 and 3 of jumpers JU2 (normal operation), and JU3 (offset binary input mode).

Common Component List (continued)

DESIGNATION	QTY	DESCRIPTION
U2	1	1.25V voltage reference (8-pin SO) MAX6161AESA or MAX6161BESA
—	5	Shunts (JU1–JU5)
—	1	MAX5875 PC board

Component Suppliers

SUPPLIER	PHONE	WEBSITE
AVX	843-946-0238	www.avxcorp.com
Coilcraft	847-639-6400	www.coilcraft.com
Fair-Rite Products	845-895-2055	www.fair-rite.com
IRC	361-992-7900	www.ircct.com
Kemet	864-963-6300	www.kemet.com
Mini-Circuits	718-934-4500	www.minicircuits.com
Taiyo Yuden	800-348-2496	www.t-yuden.com
TDK	847-803-6100	www.component.tdk.com

Note: Indicate that you are using the MAX5873/MAX5874/MAX5875 when contacting these manufacturers.

- 3) Verify that no shunts are installed across jumpers JU4 and JU5 (internal reference).
- 4) Install a shunt across pin J1-37 (header J1) and ground (pin J1-38) (XOR disabled).
- 5) Install a shunt across pin J1-33 (header J1) and DGND (pin J1-34) to ground the SELIQ pin (recommended for dual-port input operation).
- 6) Synchronize the digital pattern generator (DG2020A) and the spectrum analyzer to the clock signal generator.
- 7) Connect the clock signal generator to the CLK SMA connector on the EV kit.
- 8) Verify that the digital pattern generator is programmed for valid CMOS output voltage levels and offset binary digital outputs.
- 9) Connect the digital pattern generator outputs to the J1 and J2 input header connectors on the EV kit board. See the *Pattern Generator Connection* section for proper connection.
- 10) Connect the spectrum analyzer to the OUTPUTQ SMA connector or to the OUTPUTI SMA connector.

MAX5873/MAX5874/MAX5875 Evaluation Kits

Evaluates: MAX5873/MAX5874/MAX5875

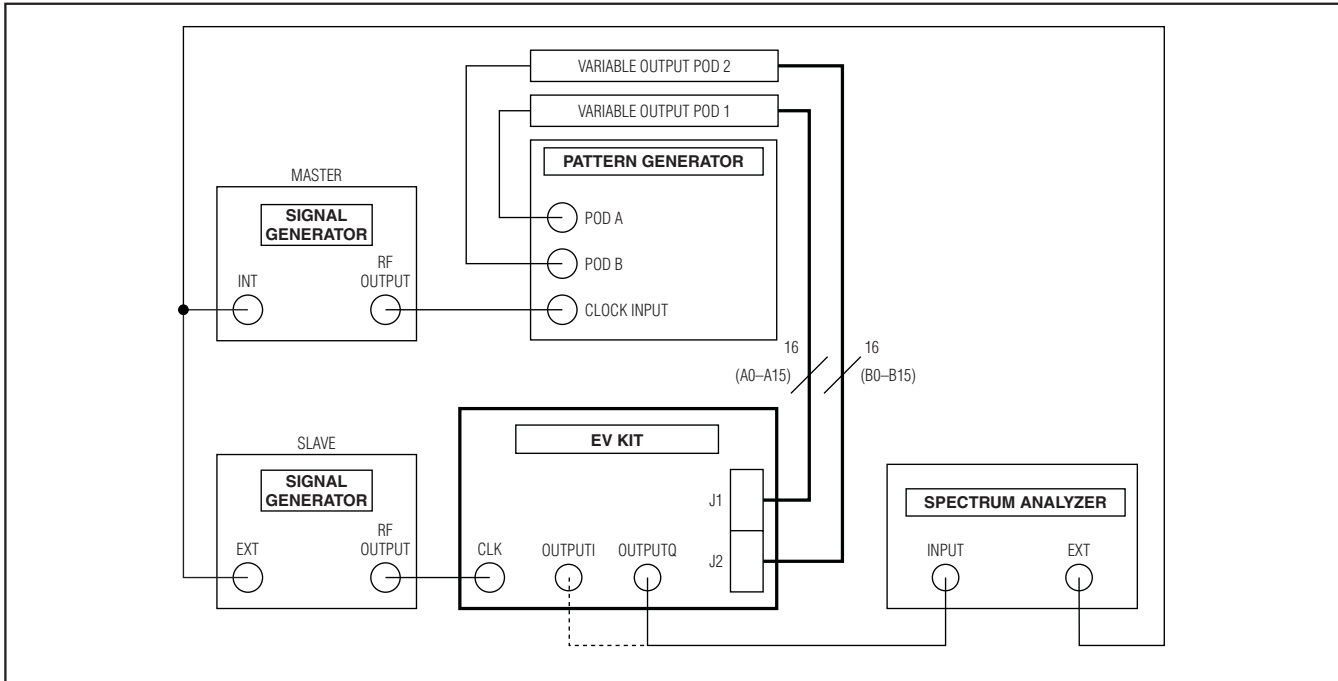

Figure 1. EV Kit Quick Start Setup

- 11) Connect a 1.8V, 100mA power supply to the AVDD1 PC board pad. Connect the ground terminal of this supply to AGND.
- 12) Connect a 3.3V, 100mA power supply to the AVDD2 PC board pad. Connect the ground terminal of this supply to AGND.
- 13) Connect a 1.8V, 100mA power supply to the DVDD1 PC board pad. Connect the ground terminal of this supply to DGND.
- 14) Connect a 3.3V, 100mA power supply to the DVDD2 PC board pad. Connect the ground terminal of this supply to DGND.
- 15) Connect a 3.3V, 100mA power supply to the VDD_CK PC board pad. Connect the ground terminal of this supply to CLKGND.
- 16) Turn on all five power supplies.
- 17) Enable the clock signal generators (HP 8664A) and the digital pattern generator.
- 18) Set the clock signal generator output power between +8dBm to +12dBm and the frequency (f_{CLK}) to ≤ 200 MHz.
- 19) Use the spectrum analyzer to view the DAC output spectrum or view the single-ended output waveforms using an oscilloscope on SMA connectors OUTPUTQ or OUTPUTI.

Detailed Description

The MAX5873/MAX5874/MAX5875 EV kits are designed to simplify the evaluation of the MAX5873 (12-bit), MAX5874 (14-bit), or MAX5875 (16-bit), 200MSPS, dual current-output DACs. The DACs operate with CMOS-compatible digital data inputs, a single-ended clock input signal, an internal 1.20V reference voltage, 3.3V and 1.8V power supplies.

The EV kits provide header connectors J1 and J2 to interface with a pattern generator, circuitry that converts the differential current outputs to single-ended voltage signals, and circuitry to convert a user-supplied single-ended clock signal to a differential clock signal. The EV kit circuit also includes an external 1.25V reference voltage source U2 (MAX6161) and a test point connector that can be used to overdrive the DACs' internal 1.20V bandgap reference. The EV kit board layout separates the circuit power into digital, analog, and clock planes to improve dynamic performance.

Power Supplies

The EV kits can operate from a single 1.8V power supply connected to the DVDD1 and AVDD1 input power pads, and a single 3.3V power supply connected to the DVDD2, AVDD2, and VDD_CK input power pads for board operation. However, five separate power supplies are recommended for optimum dynamic performance.

MAX5873/MAX5874/MAX5875 Evaluation Kits

The EV kit PC board layout is divided into three sections: digital, analog, and clock. Using separate power supplies for each section reduces crosstalk noise and improves the integrity of the output signal. When using separate power supplies, connect a 1.8V power supply across the DVDD1 and DGND pads and a 3.3V power supply across DVDD2 and DGND pads (digital). Connect a 1.8V power supply across the AVDD1 and AGND pads and a 3.3V power supply across the AVDD2 and AGND pads (analog). Connect a 3.3V power supply across the VDD_CK and CLKGND pads (clock).

CMOS Digital Input Data

The EV kits provide two 0.1in 2 x 20 headers (J1 and J2) to interface a dual CMOS pattern generator to the EV kit. The header data pins are labeled on the PC board for channel A (J1) and channel B (J2). See Table 5 for appropriate connections. Use the labels on the EV kit board to match the data bits from the pattern generator to the corresponding data pins on headers J1 and J2. The input data is latched on the rising edge of the clock signal.

The DAC SELIQ and XOR functions can also be controlled by applying a high or low logic signal to the corresponding J1 header pins. Refer to the *CMOS DAC Inputs* section in the MAX5873, MAX5874, or MAX5875 DAC data sheet for detailed information on the SELIQ and XOR functions.

Clock Signal

Each DAC operates with a differential clock input signal. However, the EV kit board only requires an external single-ended clock signal connected to the CLK SMA connector. The EV kit features circuitry that converts the single-ended clock signal to a differential clock signal. The clock signal can be either a sine or a square wave. A minimum signal power amplitude of +8dBm is recommended to drive the clock input.

Two's-Complement/Offset Binary Input Format

The DAC's two's-complement or offset binary input modes can be configured with jumper JU3. Apply either a two's-complement or offset binary formatted input code to connectors J1 and J2. See Table 1 for jumper JU3 configuration.

Dual-Port (Parallel)/Single-Port (Interleaved) Input Mode

The DAC's dual- or single-port input modes can be configured with jumper JU1. In dual-port input mode the digital input signal is captured on both input ports. In interleaved-port input mode the digital input signals are captured on channel B input port. A control signal on SELIQ indicates when I- or Q-channel data is available. See Table 2 for jumper JU1 configuration.

Table 1. TORB Configuration (Jumper JU3)

SHUNT POSITION	TORB PIN CONNECTION	EV KIT FUNCTION
1-2	Connected to DVDD2	Two's-complement digital signal input format
2-3	Connected to DGND	
Not Installed	The DAC has an internal pulldown resistor	Offset binary digital signal input format

Table 2. $\overline{\text{DORI}}$ Configuration Mode (Jumper JU1)

SHUNT LOCATION	$\overline{\text{DORI}}$ PIN CONNECTION	EV KIT FUNCTION
1-2	Connected to DVDD2	Dual-port (parallel) input mode
2-3	Connected to DGND	
Not Installed	The DAC has an internal pulldown resistor	Single-port (interleaved) input mode

MAX5873/MAX5874/MAX5875 Evaluation Kits

Evaluates: MAX5873/MAX5874/MAX5875

Reference Voltage

The DAC requires a reference voltage to set the full-scale output current. The DAC IC integrates a stable 1.20V on-chip bandgap reference that is selected by default during initial power-up. An external voltage reference must be connected to test point TP1 when the internal voltage reference is overdriven. The EV kit circuit also features an on-board external 1.25V reference voltage (U2, MAX6161) that can be used to overdrive the internal bandgap reference. U2 has a tighter voltage output tolerance and is less susceptible to temperature variations. See Table 3 to select the voltage reference source.

Full-Scale Output Current

The DAC requires an external resistor to set the full-scale output current. The EV kit full-scale current is set to 20mA by resistor R7 (2kΩ). Replace resistor R7 to adjust the full-scale output current. Refer to the *Reference Architecture and Operation* section in the respective DAC data sheet to select different values for resistor R7.

Outputs

The dual-output channels of each DAC are configured for differential current mode to achieve the best dynamic performance. The resistor and transformer networks at the DAC outputs are designed to convert the differential current signals into single-ended volt-

age signals with a 50Ω impedance. In dual-port mode, data at pins A₋ are loaded into Q-DAC and the reconstructed single-ended signal is available at OUTPUTQ SMA connector. Data at pins B₋ are loaded into I-DAC and the reconstructed single-ended signal is available at OUTPUTI SMA connector. When outputs OUTPUTQ and OUTPUTI are terminated with 50Ω external loads, the full-scale output signal level is equal to -2dBm.

To evaluate the converter's single-ended outputs, remove transformers T1 and T2. Then probe the single-ended signals at the OUTIP and OUTIN SMA connectors (must be installed) for the I-DAC. Probe the single-ended signals at the OUTQP and OUTQN SMA connectors (must be installed) for the Q-DAC. In single-ended configuration the DAC output signal amplitude is equal to 1V_{P-P} at each of the outputs.

Power-Down Mode

The DAC's EV kit power-down mode can be configured with jumper JU2. Install a shunt across pins 1 and 2 of jumper JU2 to power down the EV kit circuit. Install a shunt across pins 2 and 3 of jumper JU2 for normal operation. Removing the shunt from jumper JU2 will also place the circuit in normal operation mode, as the DAC IC contains an internal pulldown resistor at the PD pin. See Table 4 for jumper JU2 configuration.

Table 3. Reference Voltage (Jumpers JU4 and JU5)

SHUNT LOCATION ON JUMPER JU4	SHUNT LOCATION ON JUMPER JU5	REFIO PIN CONNECTION	EV KIT FUNCTION
Not Installed	Not Installed	Open (REFIO becomes the output of the internal bandgap reference)	Internal 1.20V reference enabled or connect an external reference to TP1
Installed	Installed	Connected to U2 (MAX6161)	U2 provides a precision 1.25V voltage reference

Note: Installing JU5 without JU4 is NOT allowed.

Table 4. Power-Down Configuration (Jumper JU2)

SHUNT LOCATION	PD PIN CONNECTION	EV KIT FUNCTION
1-2	Connected to DVDD2	Power-down
2-3	Connected to DGND	Normal operation
Not Installed	The DAC has an internal pulldown resistor	

MAX5873/MAX5874/MAX5875 Evaluation Kits

Pattern Generator Connection

The MAX5873, MAX5874, and MAX5875 EV kits are assembled using the same PC board. The input data connectors J1 and J2 are labeled on the PC board silk screen to accommodate connecting a 16-bit pattern generator to the MAX5875 EV kit. The silk screen input bit labels **DO NOT** match the input bit pins on the 12-bit MAX5873 and the 14-bit MAX5874 DACs. Use the connector guide (Table 5) to match the pattern generator digital output to the EV kit board connectors J1 and J2 when evaluating the MAX5873 or the MAX5874.

PC Board Layout

The MAX5873/MAX5874/MAX5875 EV kit is a four-layer PC board design optimized for high-speed signals. All high-speed signal lines are routed through 50Ω impedance-matched transmission lines. The length of these 50Ω transmission lines is matched to within 40 mils (1mm) to minimize layout-dependent data skew. The PC board layout separates the digital, analog, and clock sections of the circuit for optimum performance.

Table 5. MAX5873, MAX5874, MAX5875 EV Kit Board Connector Guide

EV KIT CONNECTOR PIN	MAX5875 INPUT	MAX5874 INPUT	MAX5873 INPUT
J1-37	XOR	XOR	XOR
J1-33	SELIQ	SELIQ	SELIQ
J2-9	A0 (LSB)	N.C.	N.C.
J2-11	A1	N.C.	N.C.
J2-13	A2	A0 (LSB)	N.C.
J2-15	A3	A1	N.C.
J2-17	A4	A2	A0 (LSB)
J2-19	A5	A3	A1
J2-21	A6	A4	A2
J2-23	A7	A5	A3
J2-25	A8	A6	A4
J2-27	A9	A7	A5
J2-29	A10	A8	A6
J2-31	A11	A9	A7
J2-33	A12	A10	A8
J2-35	A13	A11	A9
J2-37	A14	A12	A10
J2-39	A15 (MSB)	A13 (MSB)	A11 (MSB)
J1-1	B0 (LSB)	N.C.	N.C.
J1-3	B1	N.C.	N.C.
J1-5	B2	B0 (LSB)	N.C.
J1-7	B3	B1	N.C.
J1-9	B4	B2	B0 (LSB)
J1-11	B5	B3	B1
J1-13	B6	B4	B2
J1-15	B7	B5	B3
J1-17	B8	B6	B4
J1-19	B9	B7	B5
J1-21	B10	B8	B6
J1-23	B11	B9	B7
J1-25	B12	B10	B8
J1-27	B13	B11	B9
J1-29	B14	B12	B10
J1-31	B15 (MSB)	B13 (MSB)	B11 (MSB)

N.C. = No connection.

MAX5873/MAX5874/MAX5875 Evaluation Kits

Evaluates: MAX5873/MAX5874/MAX5875

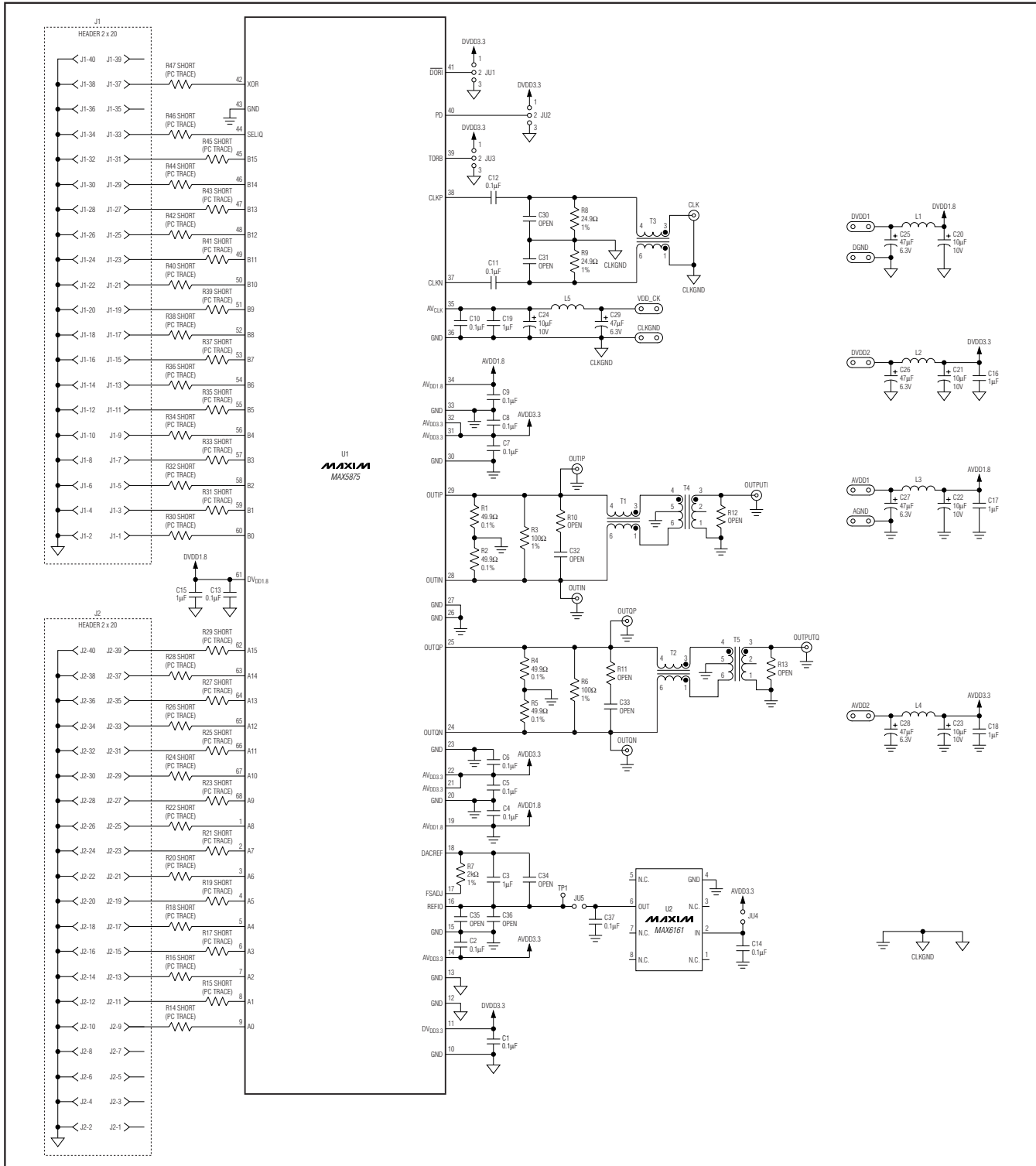

Figure 2. MAX5875 EV Kit Schematic



MAX5873/MAX5874/MAX5875 Evaluation Kits

Evaluates: MAX5873/MAX5874/MAX5875

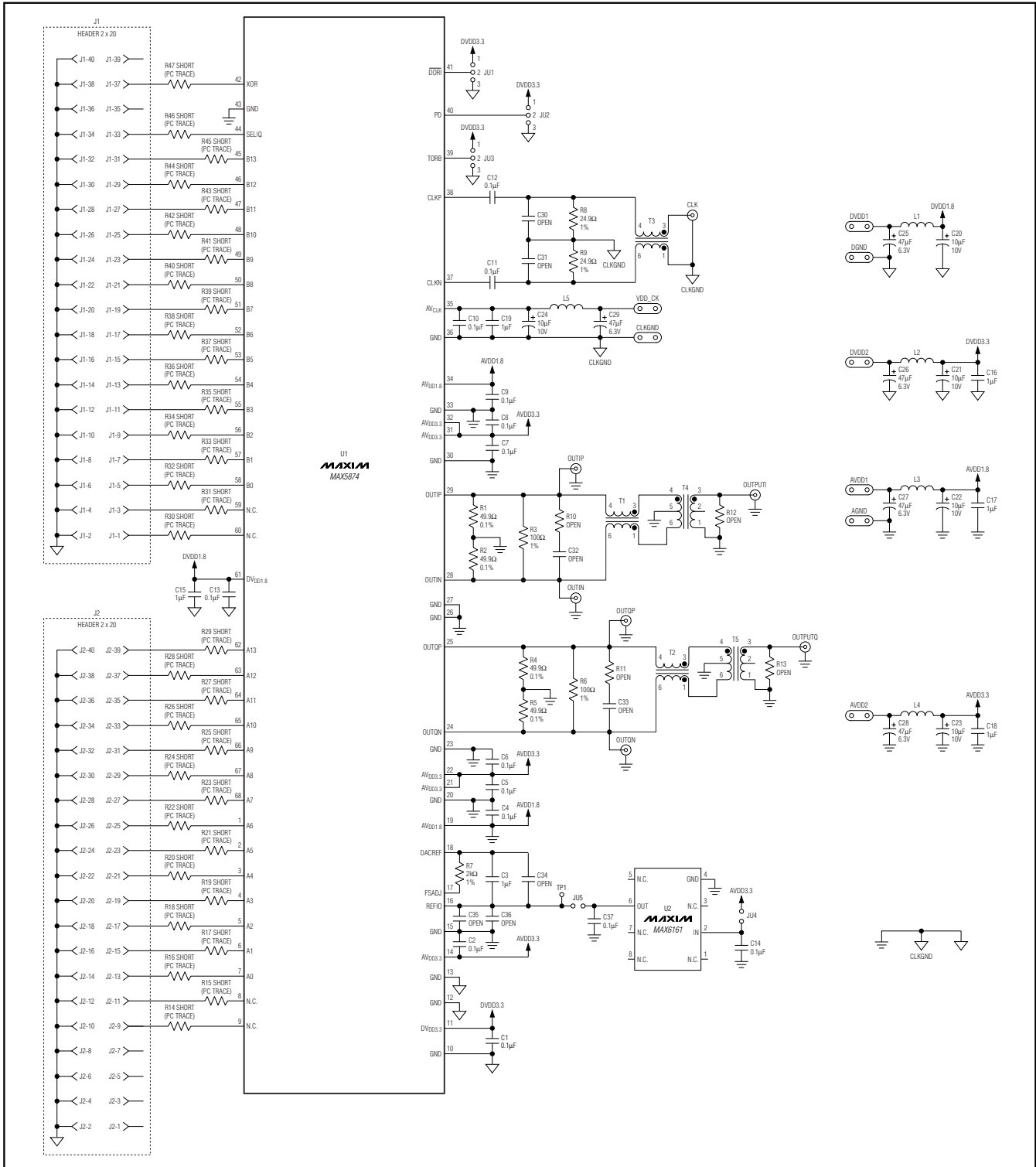

Figure 3. MAX5874 EV Kit Schematic

MAX5873/MAX5874/MAX5875 Evaluation Kits

Evaluates: MAX5873/MAX5874/MAX5875

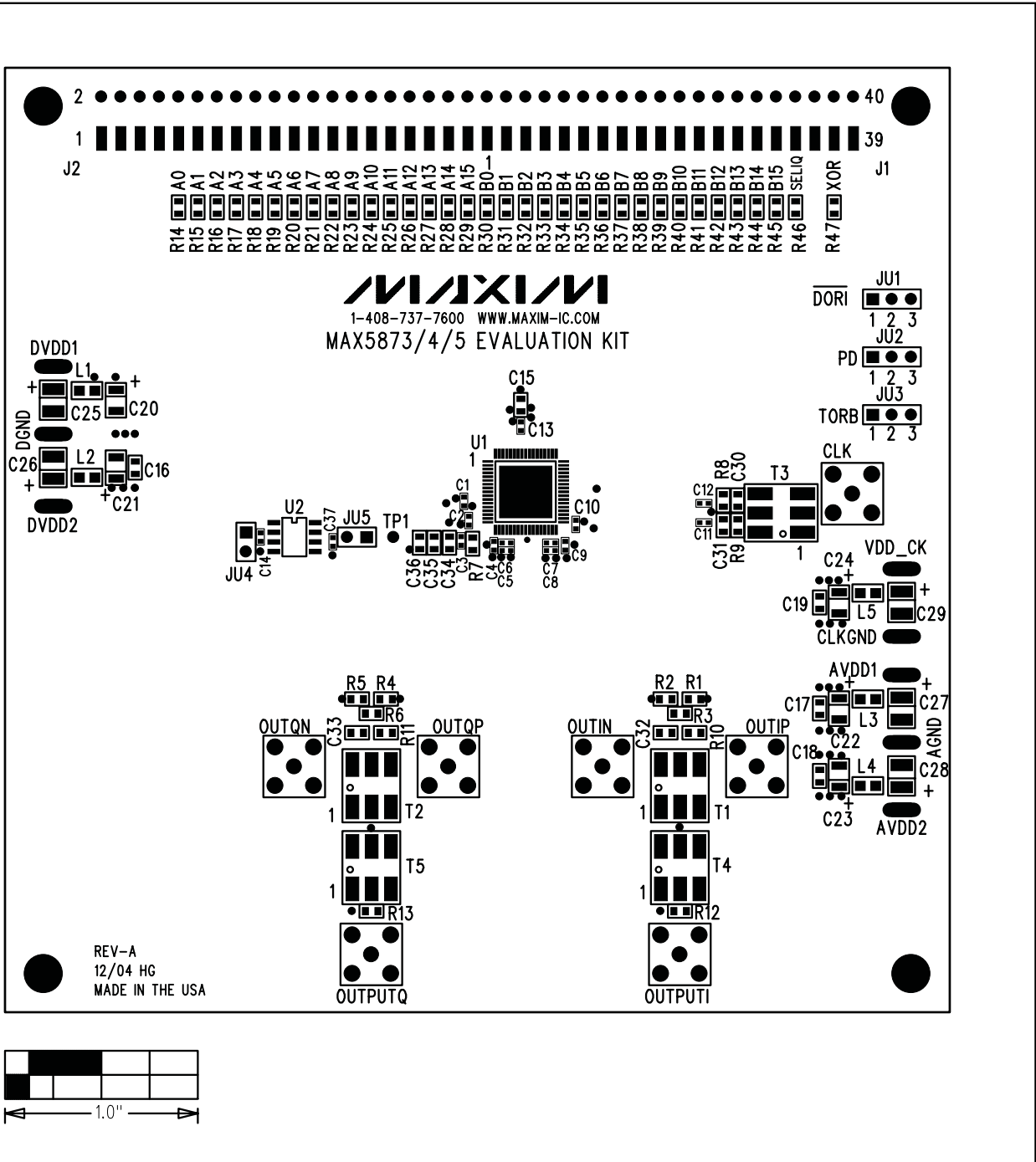

Figure 5. MAX5873/MAX5874/MAX5875 EV Kit Component Placement Guide—Component Side

MAX5873/MAX5874/MAX5875 Evaluation Kits

Evaluates: MAX5873/MAX5874/MAX5875

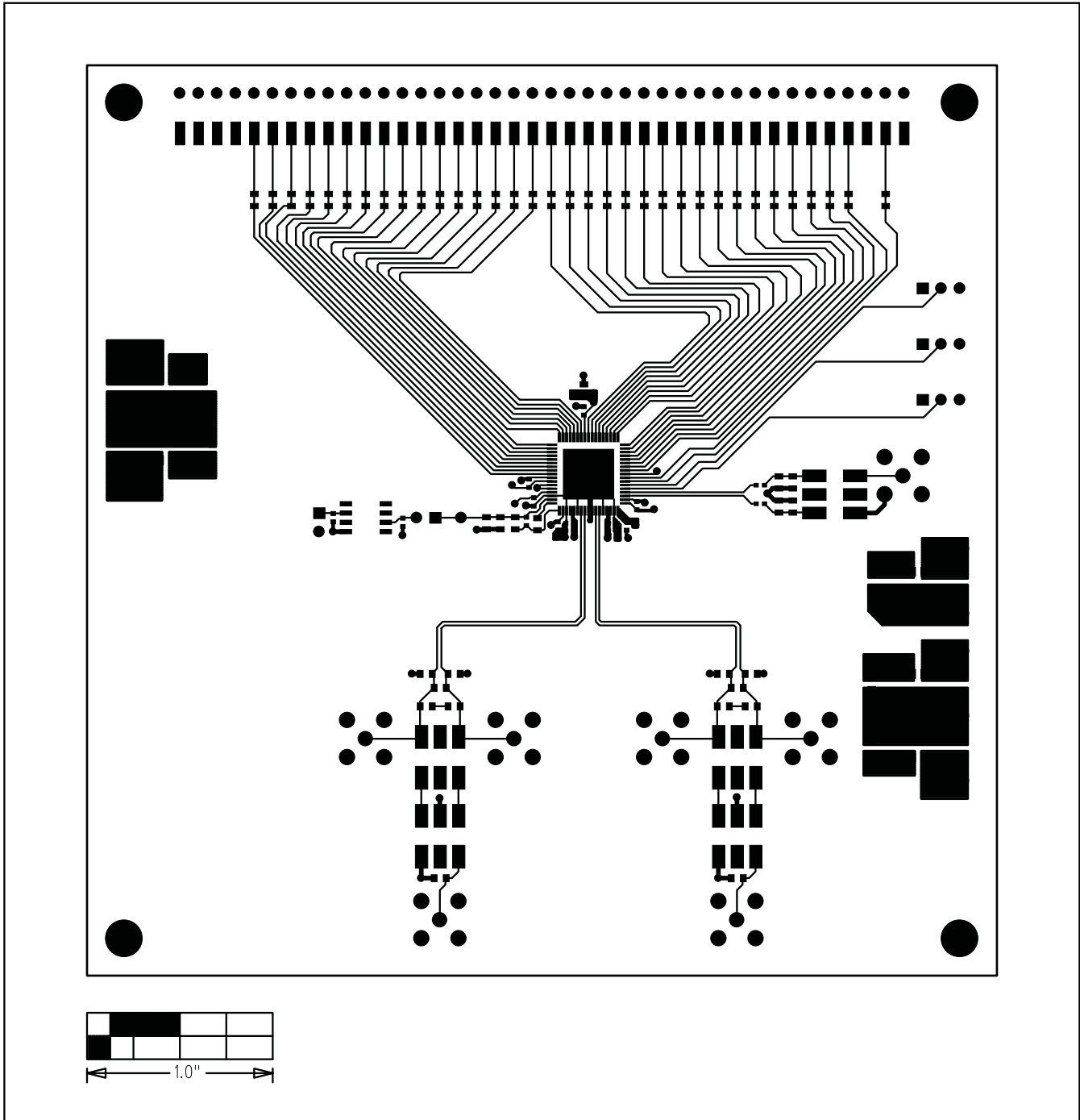

Figure 6. MAX5873/MAX5874/MAX5875 EV Kit PC Board Layout—Component Side (Layer 1)

MAX5873/MAX5874/MAX5875 Evaluation Kits

Evaluates: MAX5873/MAX5874/MAX5875

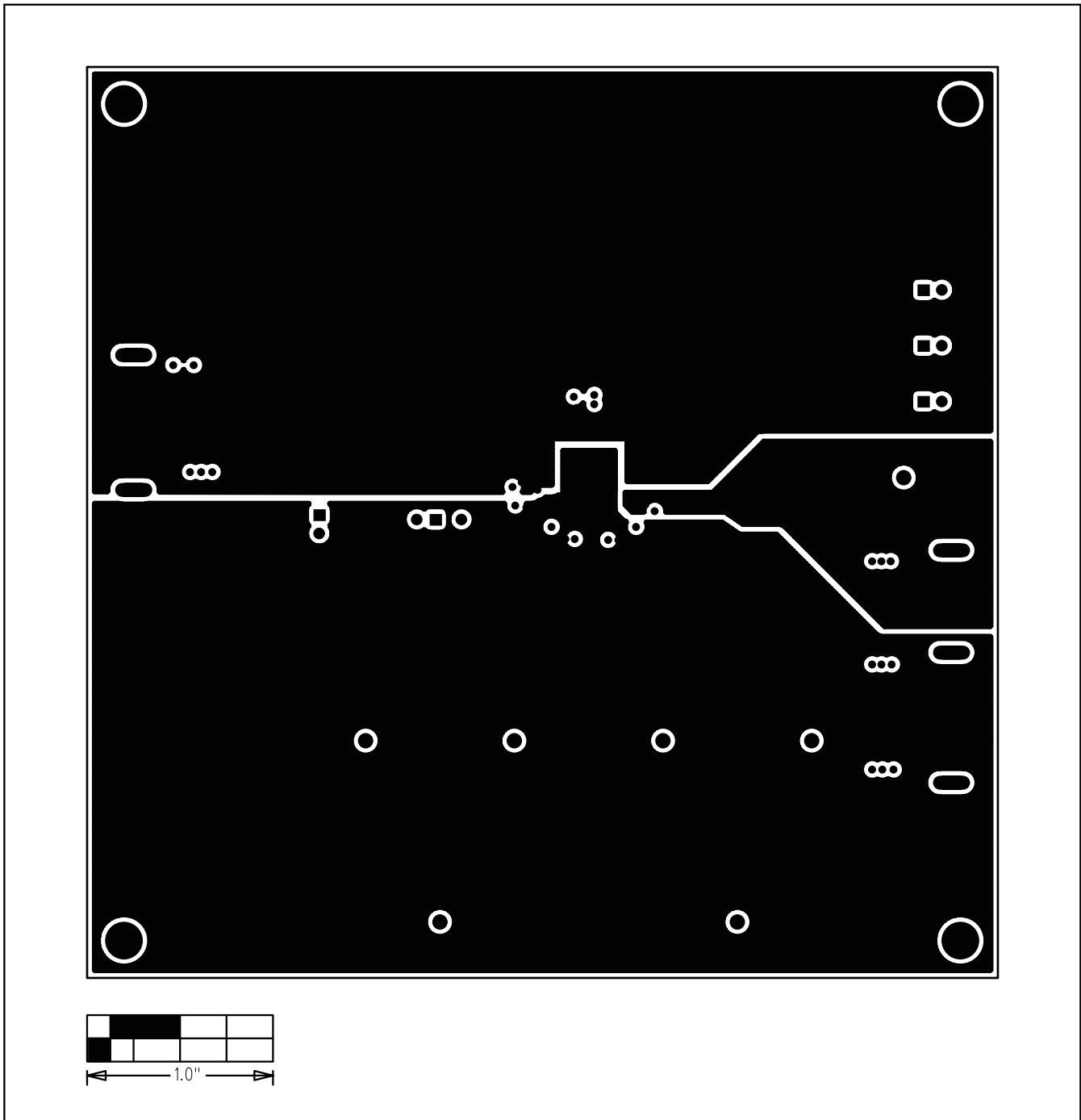

Figure 7. MAX5873/MAX5874/MAX5875 EV Kit PC Board Layout—Ground Planes (Layer 2)

MAX5873/MAX5874/MAX5875 Evaluation Kits

Evaluates: MAX5873/MAX5874/MAX5875

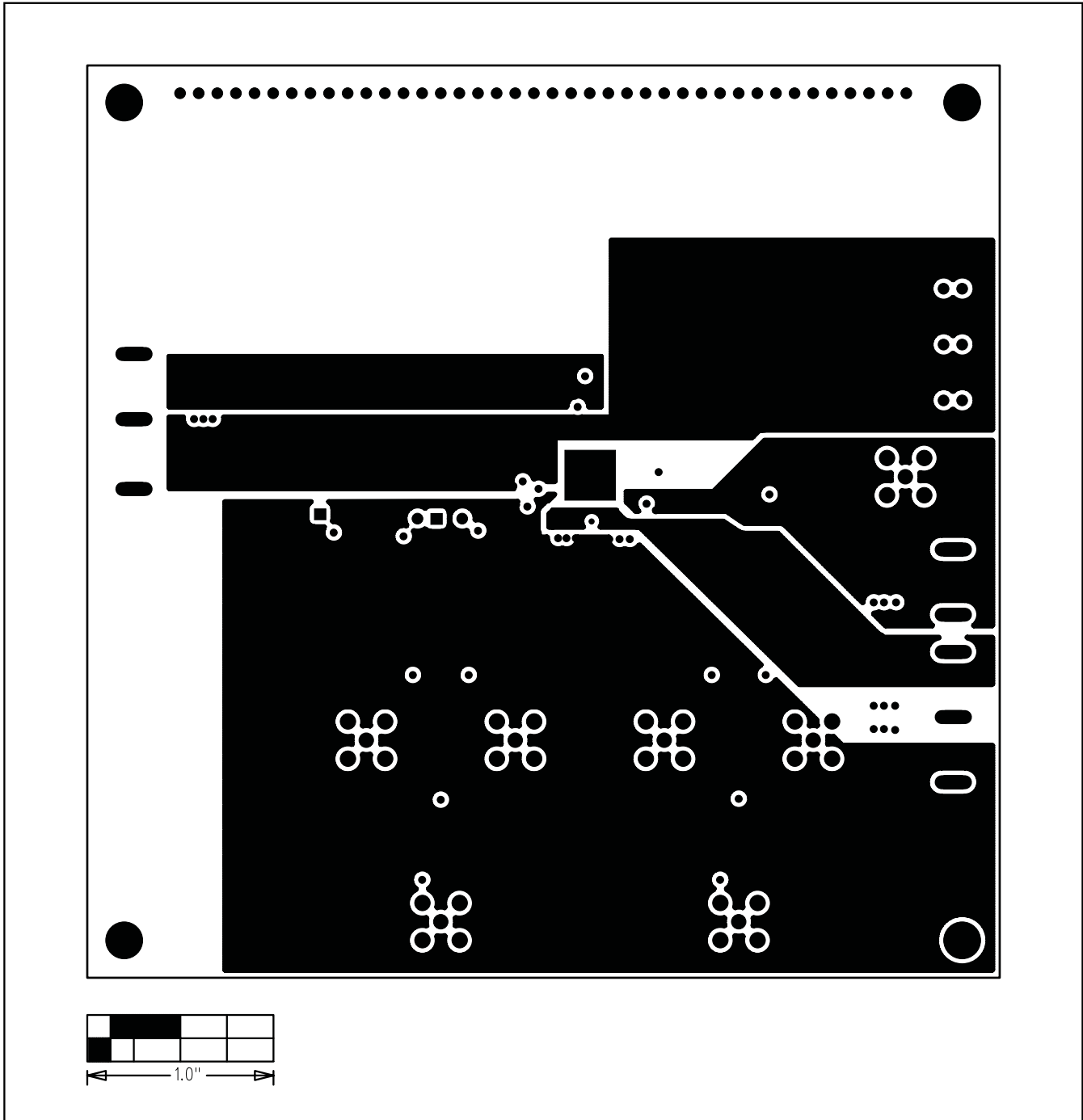

Figure 8. MAX5873/MAX5874/MAX5875 EV Kit PC Board Layout—Power Planes (Layer 3)

MAX5873/MAX5874/MAX5875 Evaluation Kits

Evaluates: MAX5873/MAX5874/MAX5875

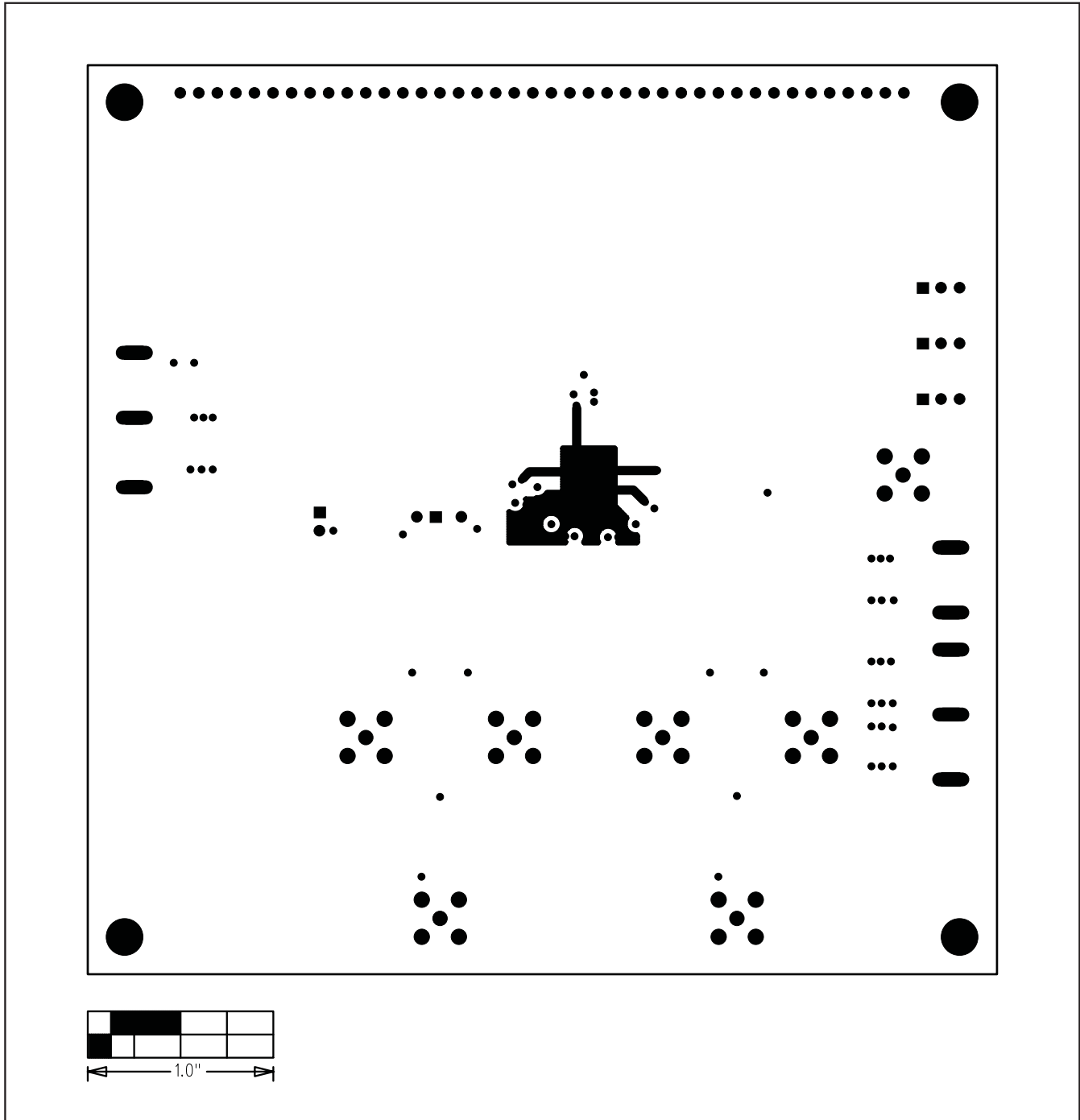

Figure 9. MAX5873/MAX5874/MAX5875 EV Kit PC Board Layout—Solder Side (Layer 4)

Maxim cannot assume responsibility for use of any circuitry other than circuitry entirely embodied in a Maxim product. No circuit patent licenses are implied. Maxim reserves the right to change the circuitry and specifications without notice at any time.

14 _____ **Maxim Integrated Products, 120 San Gabriel Drive, Sunnyvale, CA 94086 408-737-7600**

© 2006 Maxim Integrated Products

MAXIM is a registered trademark of Maxim Integrated Products, Inc.