

MAX5803/MAX5804/MAX5805

Ultra-Small, Single-Channel, 8-/10-/12-Bit Buffered Output Voltage DACs with Internal Reference and I²C Interface

ABSOLUTE MAXIMUM RATINGS

V _{DD} to GND.....	-0.3V to +6V	Maximum Continuous Current into Any Pin	±50mA
V _{DDIO} to GND	-0.3V to +6V	Operating Temperature Range	-40°C to +125°C
OUT, REF to GND	-0.3V to lower of (V _{DD} + 0.3V) and +6V	Storage Temperature Range.....	-65°C to +150°C
SCL, SDA, AUX, LDAC to GND	-0.3V to +6V	Lead Temperature (soldering, 10s)	+300°C
ADDR to GND	-0.3V to lower of (V _{DDIO} + 0.3V) and +6V	Soldering Temperature (reflow)	+260°C
Continuous Power Dissipation (T _A = +70°C)			
TDFN (derate 14.9mW/°C above +70°C).....	1188.7mW		
μMAX (derate 8.8mW/°C above +70°C)	707.3mW		

Stresses beyond those listed under "Absolute Maximum Ratings" may cause permanent damage to the device. These are stress ratings only, and functional operation of the device at these or any other conditions beyond those indicated in the operational sections of the specifications is not implied. Exposure to absolute maximum rating conditions for extended periods may affect device reliability.

PACKAGE THERMAL CHARACTERISTICS (Note 1)

TDFN	
Junction-to-Ambient Thermal Resistance (θ _{JA})	67.3°C/W
μMAX	
Junction-to-Ambient Thermal Resistance (θ _{JA})	113.1°C/W
Junction-to-Ambient Thermal Resistance (θ _{JC}).....	42°C/W

Note 1: Package thermal resistances were obtained using the method described in JEDEC specification JESD51-7, using a four-layer board. For detailed information on package thermal considerations, refer to www.maximintegrated.com/thermal-tutorial.

ELECTRICAL CHARACTERISTICS

(V_{DD} = 2.7V to 5.5V, V_{DDIO} = 1.8V to 5.5V, V_{GND} = 0V, C_L = 200pF, R_L = 2kΩ, T_A = -40°C to +125°C, unless otherwise noted.)
(Note 2)

PARAMETER	SYMBOL	CONDITIONS	MIN	TYP	MAX	UNITS
DC PERFORMANCE (Note 3)						
Resolution and Monotonicity	N	MAX5803	8			Bits
		MAX5804	10			
		MAX5805	12			
Integral Nonlinearity (Note 4)	INL	MAX5803, 8 bits	-0.25	±0.05	+0.25	LSB
		MAX5804, 10 bits	-0.5	±0.2	+0.5	
		MAX5805, 12 bits	-1	±0.5	+1	
Differential Nonlinearity (Note 4)	DNL	MAX5803, 8 bits	-0.25	±0.05	+0.25	LSB
		MAX5804, 10 bits	-0.5	±0.1	+0.5	
		MAX5805, 12 bits	-1	±0.2	+1	
Offset Error (Note 5)	OE		-5	±0.5	+5	mV
Offset Error Drift				±10		μV/°C
Gain Error (Note 5)	GE		-1.0	±0.1	+1.0	%FS
Gain Temperature Coefficient		With respect to V _{REF}		±2.5		ppm of FS/°C
Zero-Scale Error			0		+10	mV
Full-Scale Error		With respect to V _{REF}	-0.5		+0.5	%FS

MAX5803/MAX5804/MAX5805

Ultra-Small, Single-Channel, 8-/10-/12-Bit Buffered Output Voltage DACs with Internal Reference and I²C Interface

ELECTRICAL CHARACTERISTICS (continued)

(V_{DD} = 2.7V to 5.5V, V_{DDIO} = 1.8V to 5.5V, V_{GND} = 0V, C_L = 200pF, R_L = 2kΩ, T_A = -40°C to +125°C, unless otherwise noted.)
(Note 2)

PARAMETER	SYMBOL	CONDITIONS	MIN	TYP	MAX	UNITS
DAC OUTPUT CHARACTERISTICS						
Output Voltage Range (Note 6)		No load	0		V _{DD}	V
		2kΩ load to GND	0		V _{DD} - 0.2	
		2kΩ load to V _{DD}	0.2		V _{DD}	
Load Regulation		V _{OUT} = V _{FS} /2	V _{DD} = 3V ±10%, I _{OUT} ≤ 5mA	300		μV/mA
			V _{DD} = 5V ±10%, I _{OUT} ≤ 10mA	300		
DC Output Impedance		V _{OUT} = V _{FS} /2	V _{DD} = 3V ±10%, I _{OUT} ≤ 5mA	0.3		Ω
			V _{DD} = 5V ±10%, I _{OUT} ≤ 10mA	0.3		
Capacitive Load Handling	C _L			500		pF
Resistive Load Handling	R _L		2			kΩ
Short-Circuit Output Current		V _{DD} = 5.5V	Sourcing (output short to GND)	30		mA
			Sinking (output shorted to V _{DD})	40		
DYNAMIC PERFORMANCE						
Voltage-Output Slew Rate	SR	Positive and negative		2.0		V/μs
Voltage-Output Settling Time		1/4 scale to 3/4 scale, to ≤ 1 LSB, MAX5803		2.8		μs
			1/4 scale to 3/4 scale, to ≤ 1 LSB, MAX5804	5.2		
			1/4 scale to 3/4 scale, to ≤ 1 LSB, MAX5805	6.3		
DAC Glitch Impulse		Major code transition		5.0		nV·s
Digital Feedthrough		Code = 0, all digital inputs from 0V to V _{DDIO}		0.5		nV·s
Power-Up Time		Startup calibration time (Note 7)		200		μs
		From power-down mode		60		μs
DC Power-Supply Rejection		V _{DD} = 3V ±10% or 5V ±10%		100		μV/V

MAX5803/MAX5804/MAX5805

Ultra-Small, Single-Channel, 8-/10-/12-Bit Buffered Output Voltage DACs with Internal Reference and I²C Interface

ELECTRICAL CHARACTERISTICS (continued)

(V_{DD} = 2.7V to 5.5V, V_{DDIO} = 1.8V to 5.5V, V_{GND} = 0V, C_L = 200pF, R_L = 2kΩ, T_A = -40°C to +125°C, unless otherwise noted.)
(Note 2)

PARAMETER	SYMBOL	CONDITIONS		MIN	TYP	MAX	UNITS
Output Voltage-Noise Density (DAC Output at Midscale)		External reference	f = 1kHz		88		nV/√Hz
			f = 10kHz		79		
		2.048V internal reference	f = 1kHz		108		
			f = 10kHz		98		
		2.5V internal reference	f = 1kHz		117		
			f = 10kHz		110		
		4.096V internal reference	f = 1kHz		152		
			f = 10kHz		145		
Integrated Output Noise (DAC Output at Midscale)		External reference	f = 0.1Hz to 10Hz		10		μV _{P-P}
			f = 0.1Hz to 10kHz		72		
			f = 0.1Hz to 300kHz		298		
		2.048V internal reference	f = 0.1Hz to 10Hz		11		
			f = 0.1Hz to 10kHz		89		
			f = 0.1Hz to 300kHz		370		
		2.5V internal reference	f = 0.1Hz to 10Hz		12		
			f = 0.1Hz to 10kHz		99		
			f = 0.1Hz to 300kHz		355		
		4.096V internal reference	f = 0.1Hz to 10Hz		13		
			f = 0.1Hz to 10kHz		128		
			f = 0.1Hz to 300kHz		400		
Output Voltage-Noise Density (DAC Output at Full Scale)		External reference	f = 1kHz		113		nV/√Hz
			f = 10kHz		100		
		2.048V internal reference	f = 1kHz		172		
			f = 10kHz		157		
		2.5V internal reference	f = 1kHz		195		
			f = 10kHz		180		
		4.096V internal reference	f = 1kHz		279		
			f = 10kHz		258		
Integrated Output Noise (DAC Output at Full Scale)		External reference	f = 0.1Hz to 10Hz		12		μV _{P-P}
			f = 0.1Hz to 10kHz		88		
			f = 0.1Hz to 300kHz		280		
		2.048V internal reference	f = 0.1Hz to 10Hz		14		
			f = 0.1Hz to 10kHz		135		
			f = 0.1Hz to 300kHz		530		
		2.5V internal reference	f = 0.1Hz to 10Hz		15		
			f = 0.1Hz to 10kHz		160		
			f = 0.1Hz to 300kHz		550		
		4.096V internal reference	f = 0.1Hz to 10Hz		23		
			f = 0.1Hz to 10kHz		220		
			f = 0.1Hz to 300kHz		610		

MAX5803/MAX5804/MAX5805

Ultra-Small, Single-Channel, 8-/10-/12-Bit Buffered Output Voltage DACs with Internal Reference and I²C Interface

ELECTRICAL CHARACTERISTICS (continued)

(V_{DD} = 2.7V to 5.5V, V_{DDIO} = 1.8V to 5.5V, V_{GND} = 0V, C_L = 200pF, R_L = 2kΩ, T_A = -40°C to +125°C, unless otherwise noted.)
(Note 2)

PARAMETER	SYMBOL	CONDITIONS	MIN	TYP	MAX	UNITS
REFERENCE INPUT						
Reference Input Range	V _{REF}		1.24		V _{DD}	V
Reference Input Current	I _{REF}	V _{REF} = V _{DD} = 5.5V		55	75	μA
Reference Input Impedance	R _{REF}		75	100		kΩ
REFERENCE OUTPUT						
Reference Output Voltage	V _{REF}	V _{REF} = 2.048V, T _A = +25°C	2.043	2.048	2.053	V
		V _{REF} = 2.5V, T _A = +25°C	2.494	2.500	2.506	
		V _{REF} = 4.096V, T _A = +25°C	4.086	4.096	4.106	
Reference Output Noise Density	V _{REF}	V _{REF} = 2.048V	f = 1kHz	129		nV/√Hz
			f = 10kHz	122		
		V _{REF} = 2.500V	f = 1kHz	158		
			f = 10kHz	151		
		V _{REF} = 4.096V	f = 1kHz	254		
			f = 10kHz	237		
Integrated Reference Output Noise	V _{REF}	V _{REF} = 2.048V	f = 0.1Hz to 10Hz	12		μV _{P-P}
			f = 0.1Hz to 10kHz	110		
			f = 0.1Hz to 300kHz	390		
		V _{REF} = 2.500V	f = 0.1Hz to 10Hz	15		
			f = 0.1Hz to 10kHz	129		
			f = 0.1Hz to 300kHz	430		
		V _{REF} = 4.096V	f = 0.1Hz to 10Hz	20		
			f = 0.1Hz to 10kHz	205		
			f = 0.1Hz to 300kHz	525		
Reference Temperature Coefficient (Note 8)		MAX5805A		±4	±12	ppm/°C
		MAX5803/MAX5804/MAX5805B		±10	±25	
Reference Drive Capacity		External load		25		kΩ
Reference Capacitive Load Handling				200		pF
Reference Load Regulation		I _{SOURCE} = 0 to 500μA		1.0		mV/mA
Reference Line Regulation				0.1		mV/V

MAX5803/MAX5804/MAX5805

Ultra-Small, Single-Channel, 8-/10-/12-Bit Buffered Output Voltage DACs with Internal Reference and I²C Interface

ELECTRICAL CHARACTERISTICS (continued)

(V_{DD} = 2.7V to 5.5V, V_{DDIO} = 1.8V to 5.5V, V_{GND} = 0V, C_L = 200pF, R_L = 2kΩ, T_A = -40°C to +125°C, unless otherwise noted.)
(Note 2)

PARAMETER	SYMBOL	CONDITIONS		MIN	TYP	MAX	UNITS
POWER REQUIREMENTS							
Supply Voltage	V _{DD}	V _{REF} = 4.096V		4.5		5.5	V
		All other options		2.7		5.5	
I/O Supply Voltage	V _{DDIO}			1.8		5.5	V
Supply Current (DAC Output at Midscale) (Note 9)	I _{DD}	External reference	V _{REF} = 3V		135	190	μA
			V _{REF} = 5V		165	225	
		Internal reference, reference pin undriven	V _{REF} = 2.048V		190	265	
			V _{REF} = 2.5V		205	280	
			V _{REF} = 4.096V		250	340	
		Internal reference, reference pin driven	V _{REF} = 2.048V		215	300	
V _{REF} = 2.5V			225	315			
V _{REF} = 4.096V			275	375			
Supply Current (DAC Output at Full Scale) (Note 9)	I _{DD}	External reference	V _{REF} = 3V		155	210	μA
			V _{REF} = 5V		200	265	
		Internal reference, reference pin undriven	V _{REF} = 2.048V		205	280	
			V _{REF} = 2.5V		220	300	
			V _{REF} = 4.096V		275	375	
		Internal reference, reference pin driven	V _{REF} = 2.048V		225	310	
V _{REF} = 2.5V			240	330			
V _{REF} = 4.096V			300	410			
Power-Down Mode Supply Current (DAC Powered Down, Reference Remains Active) (Note 9)	I _{DD}	Internal reference, reference pin driven	V _{REF} = 2.048V		90	135	μA
			V _{REF} = 2.5V		93	135	
			V _{REF} = 4.096V		100	150	
Power-Down Mode Supply Current (Note 9)	I _{PD}	External reference, V _{DD} = V _{REF}			0.4	2	μA
Digital Supply Current (Note 9)	I _{DDIO}					1.0	μA
DIGITAL INPUT CHARACTERISTICS (SCL, SDA, ADDR, AUX, LDAC)							
Input High Voltage	V _{IH}	2.2V < V _{DDIO} < 5.5V		0.7 x			V
		1.8V < V _{DDIO} < 2.2V		0.8 x			
Input Low Voltage	V _{IL}	2.2V < V _{DDIO} < 5.5V				0.3 x	V
		1.8V < V _{DDIO} < 2.2V				0.2 x	

MAX5803/MAX5804/MAX5805

Ultra-Small, Single-Channel, 8-/10-/12-Bit Buffered Output Voltage DACs with Internal Reference and I²C Interface

ELECTRICAL CHARACTERISTICS (continued)

(V_{DD} = 2.7V to 5.5V, V_{DDIO} = 1.8V to 5.5V, V_{GND} = 0V, C_L = 200pF, R_L = 2kΩ, T_A = -40°C to +125°C, unless otherwise noted.)
(Note 2)

PARAMETER	SYMBOL	CONDITIONS	MIN	TYP	MAX	UNITS
Hysteresis Voltage	V _H			0.15		V
Input Leakage Current (Note 9)	I _{IN}			±0.1	±1	μA
Input Capacitance	C _{IN}			3		pF
ADDR Pullup/Pulldown Strength	R _{PU} , R _{PD}	(Note 10)	30	50	90	kΩ
DIGITAL OUTPUT (SDA)						
Output Low Voltage	V _{OL}	I _{SINK} = 3mA			0.2	V
I²C TIMING CHARACTERISTICS (SCL, SDA, AUX, LDAC)						
SCL Clock Frequency	f _{SCL}				400	kHz
Bus Free Time Between a STOP and a START Condition	t _{BUF}		1.3			μs
Hold Time Repeated for a START Condition	t _{HD;STA}		0.6			μs
SCL Pulse Width Low	t _{LOW}		1.3			μs
SCL Pulse Width High	t _{HIGH}		0.6			μs
Setup Time for Repeated START Condition	t _{SU;STA}		0.6			μs
Data Hold Time	t _{HD;DAT}		0		900	ns
Data Setup Time	t _{SU;DAT}		100			ns
SDA and SCL Receiving Rise Time	t _R		20 + C _B /10		300	ns
SDA and SCL Receiving Fall Time	t _F		20 + C _B /10		300	ns
SDA Transmitting Fall Time	t _F		20 + C _B /10		250	ns
Setup Time for STOP Condition	t _{SU;STO}		0.6			μs
Bus Capacitance Allowed	C _B	V _{DD} = 2.7V to 5.5V	10		400	pF
Pulse Width of Suppressed Spike	t _{SP}			50		ns
CL _R Removal Time Prior to a Recognized START	t _{CLRSTA}		100			ns
CL _R Pulse Width Low	t _{CLPW}		20			ns
LDAC Pulse Width Low	t _{LDPW}		20			ns
LDAC Fall to SCLK Fall to Hold	t _{LDH}	Applies to execution edge	400			ns

MAX5803/MAX5804/MAX5805

Ultra-Small, Single-Channel, 8-/10-/12-Bit Buffered Output Voltage DACs with Internal Reference and I²C Interface

ELECTRICAL CHARACTERISTICS (continued)

($V_{DD} = 2.7V$ to $5.5V$, $V_{DDIO} = 1.8V$ to $5.5V$, $V_{GND} = 0V$, $C_L = 200pF$, $R_L = 2k\Omega$, $T_A = -40^\circ C$ to $+125^\circ C$, unless otherwise noted.)
(Note 2)

Note 2: Electrical specifications are production tested at $T_A = +25^\circ C$. Specifications over the entire operating temperature range are guaranteed by design and characterization. Typical specifications are at $T_A = +25^\circ C$.

Note 3: DC Performance is tested without load.

Note 4: Linearity is tested with unloaded outputs to within 20mV of GND and V_{DD} .

Note 5: Gain and offset calculated from measurements made with $V_{REF} = V_{DD}$ at code 30 and 4065 for MAX5805, code 8 and 1016 for MAX5804, and code 2 and 254 for MAX5803.

Note 6: Subject to zero and full-scale error limits and V_{REF} settings.

Note 7: On power-up, the device initiates an internal 200 μs (typ) calibration sequence. All commands issued during this time will be ignored.

Note 8: Specification is guaranteed by design and characterization.

Note 9: Static logic inputs with $V_{IL} = V_{GND}$ and $V_{IH} = V_{DDIO}$.

Note 10: An unconnected condition on ADDR is sensed via a resistive pullup and pulldown operation; for proper operation, ADDR should be tied to V_{DDIO} , GND, or left unconnected with minimal capacitance.

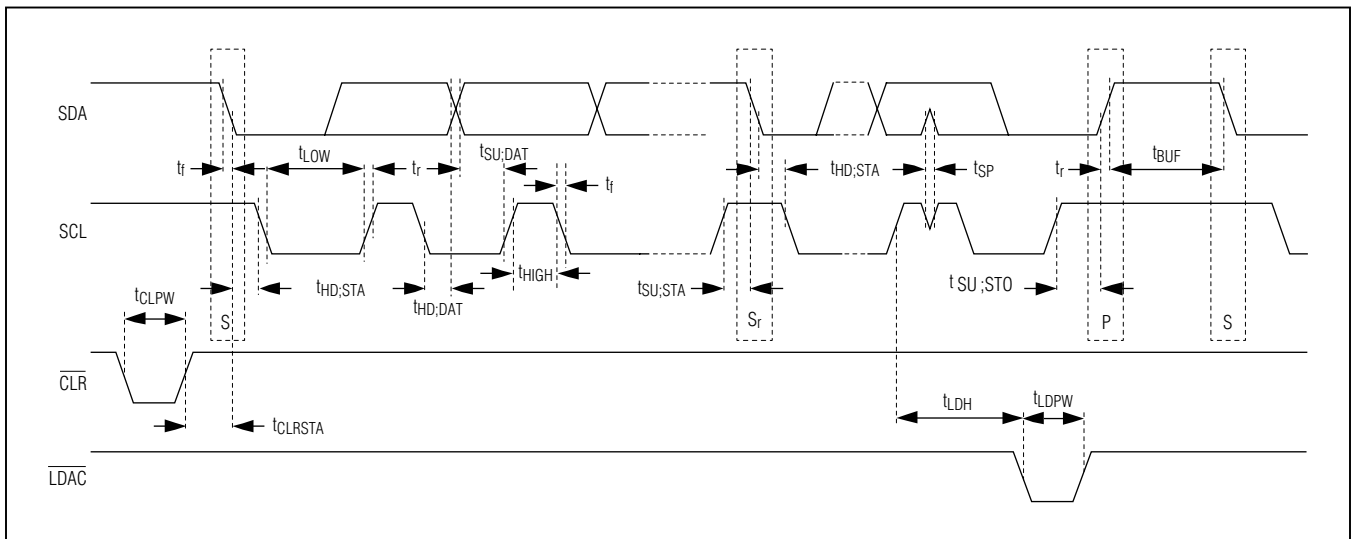

Figure 1. I²C Serial Interface Timing Diagram

MAX5803/MAX5804/MAX5805

Ultra-Small, Single-Channel, 8-/10-/12-Bit Buffered Output Voltage DACs with Internal Reference and I²C Interface

Typical Operating Characteristics

(MAX5805, 12-bit performance, $T_A = +25^\circ\text{C}$, unless otherwise noted.)

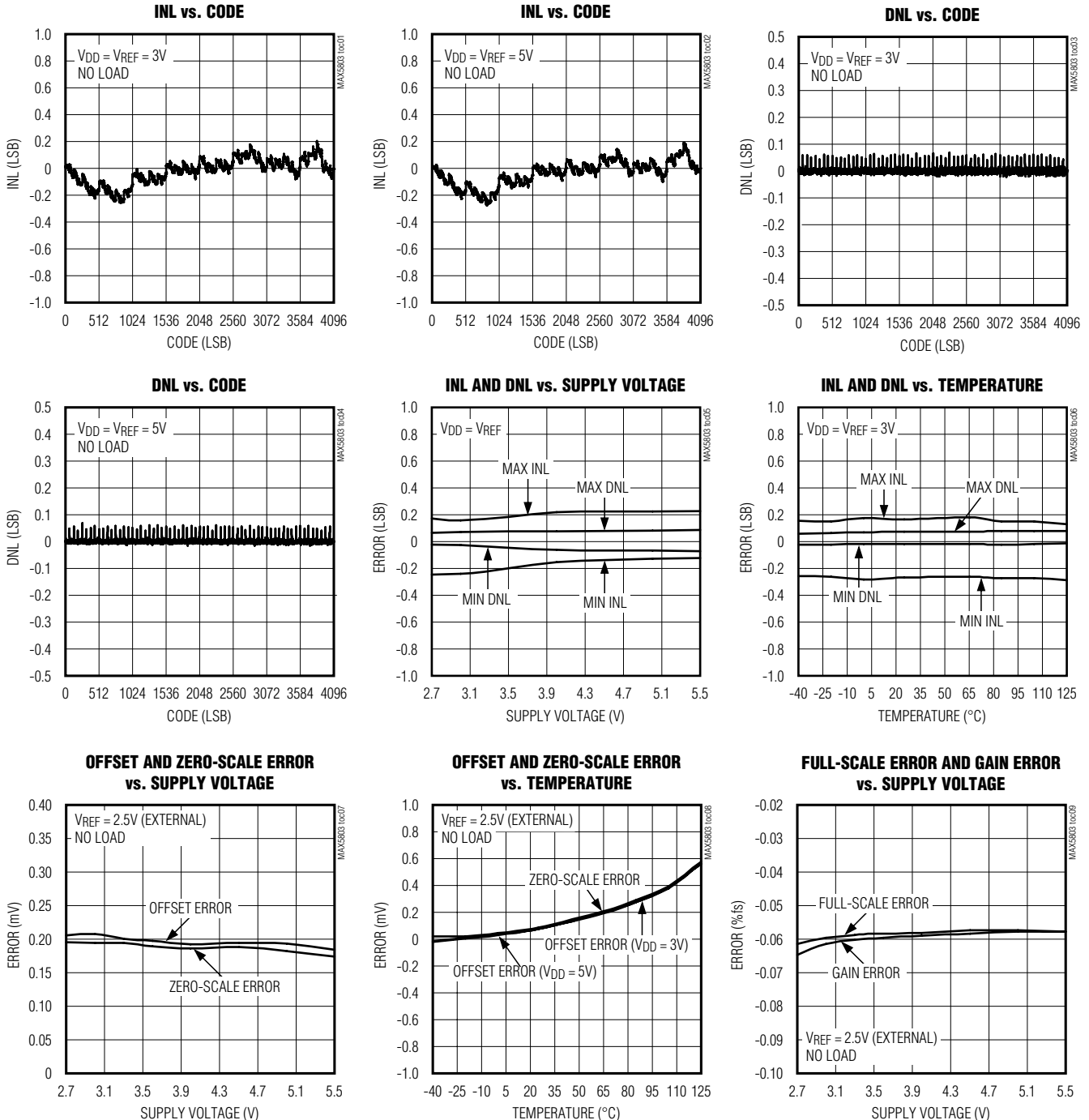

MAX5803/MAX5804/MAX5805

Ultra-Small, Single-Channel, 8-/10-/12-Bit Buffered Output Voltage DACs with Internal Reference and I²C Interface

Typical Operating Characteristics (continued)

(MAX5805, 12-bit performance, $T_A = +25^\circ\text{C}$, unless otherwise noted.)

FULL-SCALE ERROR AND GAIN ERROR vs. TEMPERATURE

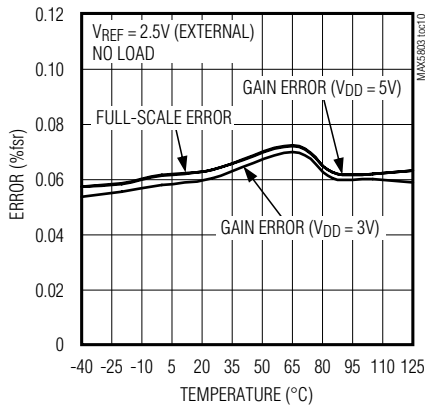

SUPPLY CURRENT vs. TEMPERATURE (PIN UNDRIVEN FOR INTERNAL REF MODES)

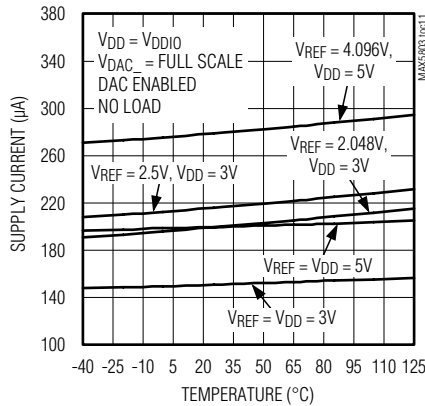

SUPPLY CURRENT vs. SUPPLY VOLTAGE (2.048V INTERNAL REFERENCE)

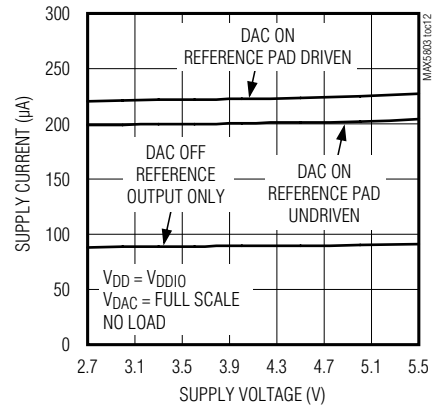

SUPPLY CURRENT vs. SUPPLY VOLTAGE (2.500V INTERNAL REFERENCE)

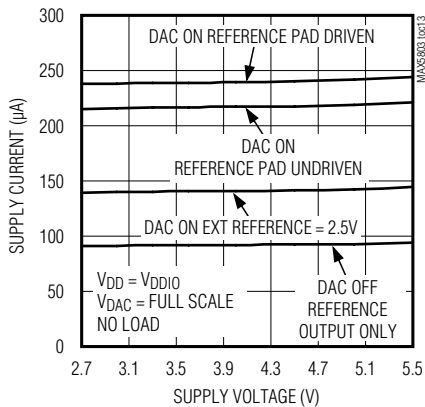

SUPPLY CURRENT vs. SUPPLY VOLTAGE (4.096V INTERNAL REFERENCE)

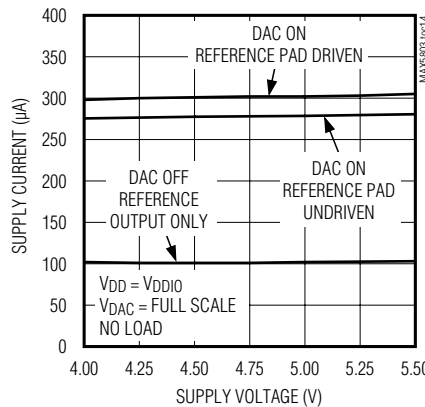

POWER-DOWN MODE SUPPLY CURRENT vs. SUPPLY VOLTAGE

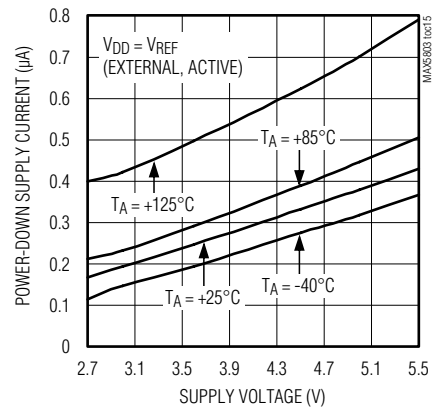

SUPPLY CURRENT vs. CODE (FOR INTERNAL REF, PIN IS UNDRIVEN)

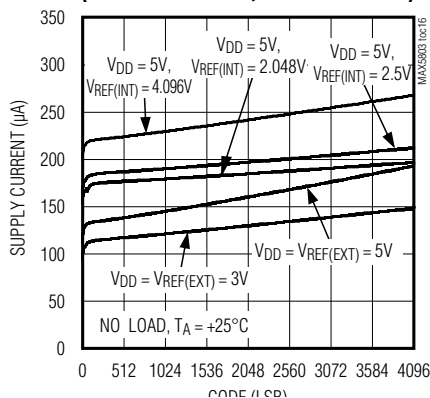

IREF (EXTERNAL) vs. CODE

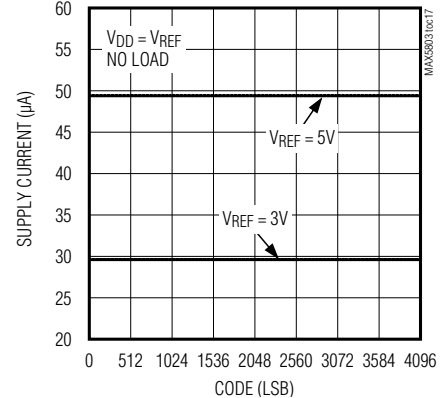

MAX5803/MAX5804/MAX5805

Ultra-Small, Single-Channel, 8-/10-/12-Bit Buffered Output Voltage DACs with Internal Reference and I²C Interface

Typical Operating Characteristics (continued)

(MAX5805, 12-bit performance, $T_A = +25^\circ\text{C}$, unless otherwise noted.)

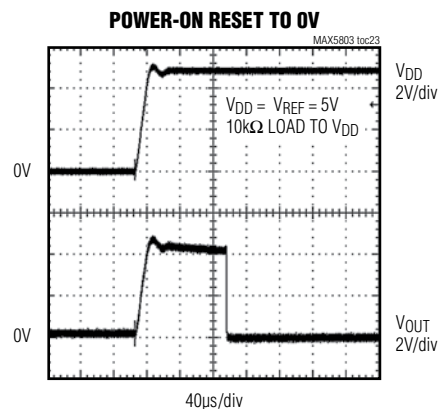
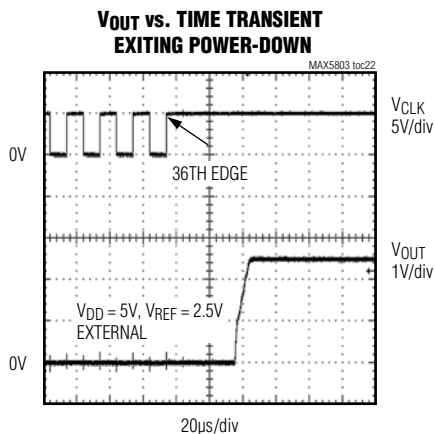
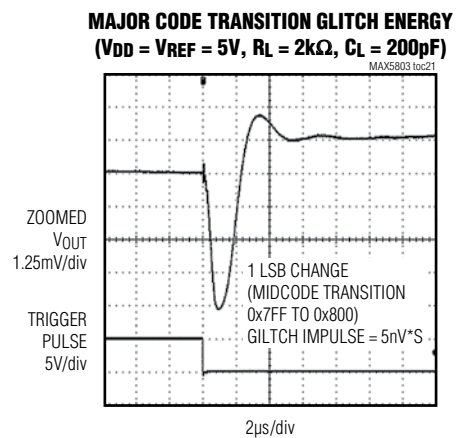
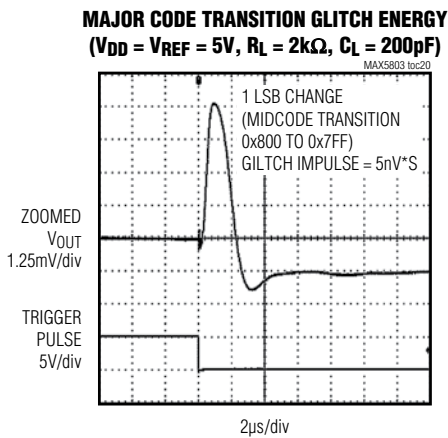
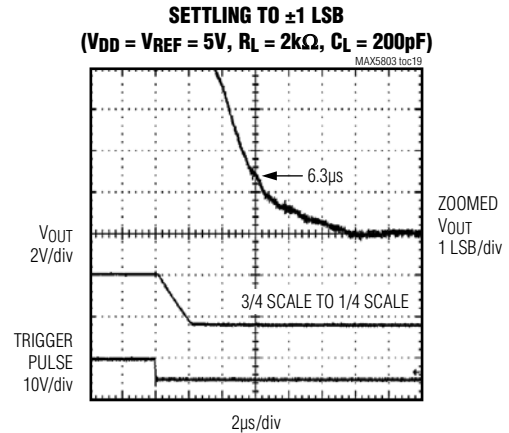
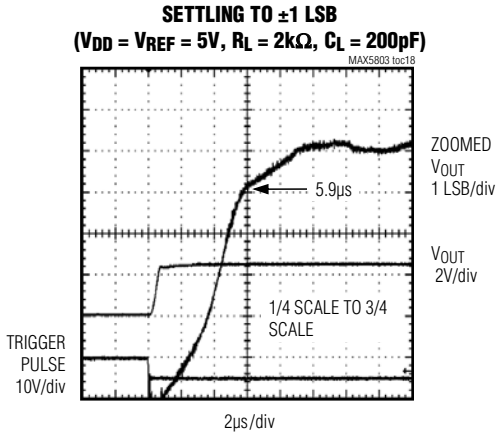

MAX5803/MAX5804/MAX5805

Ultra-Small, Single-Channel, 8-/10-/12-Bit Buffered Output Voltage DACs with Internal Reference and I²C Interface

Typical Operating Characteristics (continued)

(MAX5805, 12-bit performance, $T_A = +25^\circ\text{C}$, unless otherwise noted.)

DIGITAL FEEDTHROUGH
($V_{DD} = V_{REF} = 5\text{V}$, $R_L = 2\text{k}\Omega$, $C_L = 200\text{pF}$)

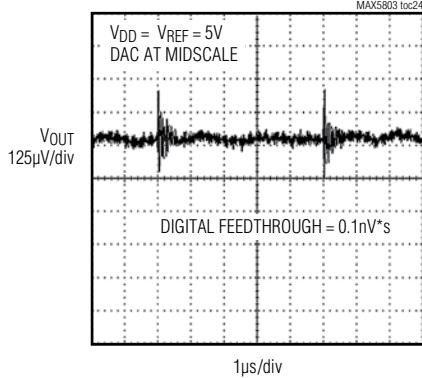

OUTPUT LOAD REGULATION

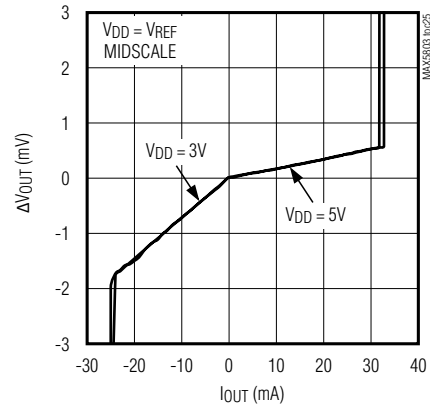

OUTPUT CURRENT LIMITING

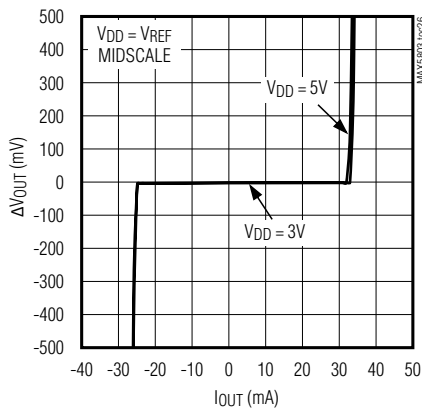

HEADROOM AT RAILS vs. OUTPUT CURRENT ($V_{DD} = V_{REF}$)

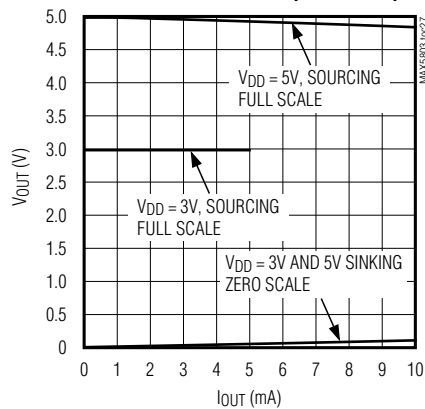

NOISE-VOLTAGE DENSITY vs. FREQUENCY (DAC AT MIDSCALE)

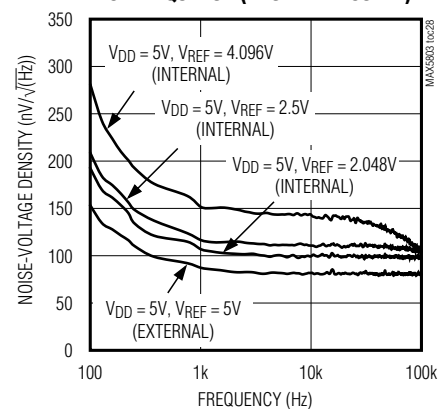

0.1Hz TO 10Hz OUTPUT NOISE, EXTERNAL REFERENCE ($V_{DD} = 5\text{V}$, $V_{REF} = 4.5\text{V}$)

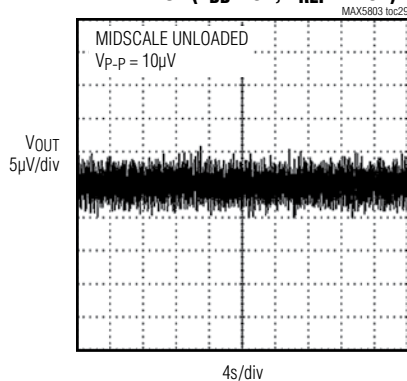

0.1Hz TO 10Hz OUTPUT NOISE, INTERNAL REFERENCE ($V_{DD} = 5\text{V}$, $V_{REF} = 2.048\text{V}$)

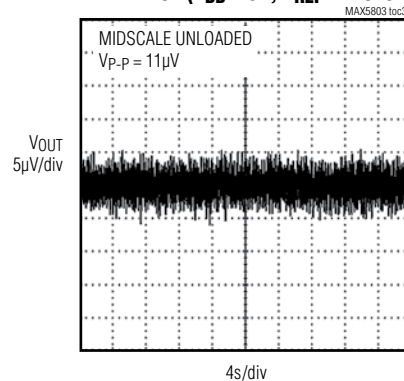

MAX5803/MAX5804/MAX5805

Ultra-Small, Single-Channel, 8-/10-/12-Bit Buffered Output Voltage DACs with Internal Reference and I²C Interface

Typical Operating Characteristics (continued)

(MAX5805, 12-bit performance, $T_A = +25^\circ\text{C}$, unless otherwise noted.)

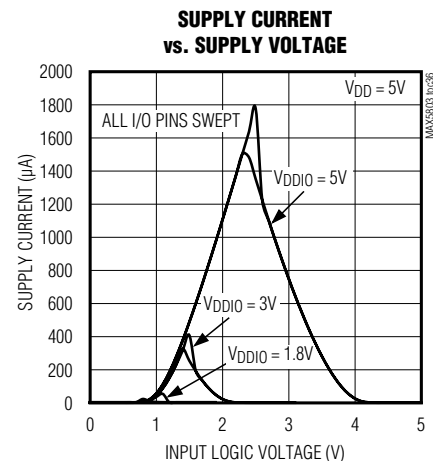
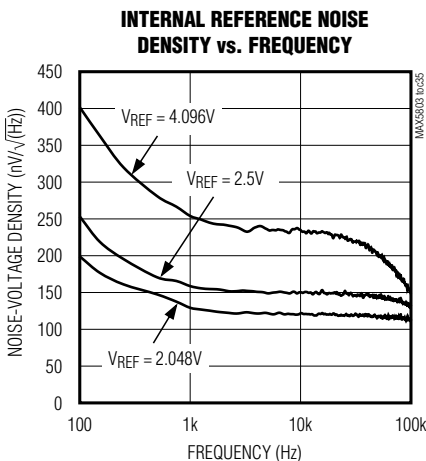
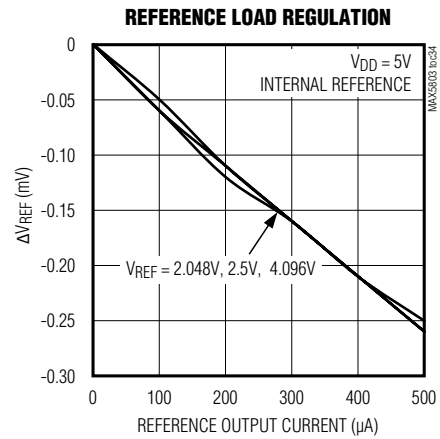
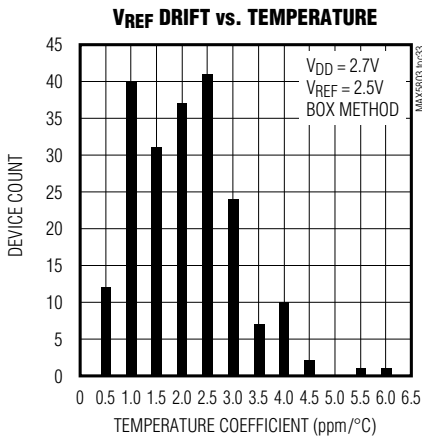
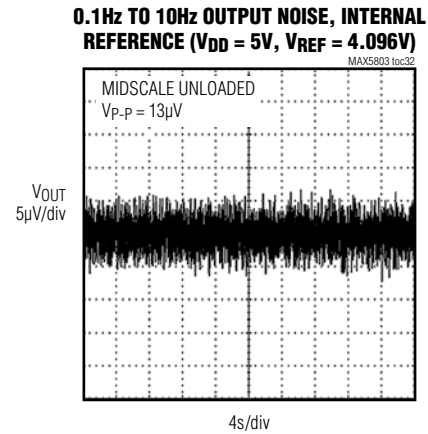
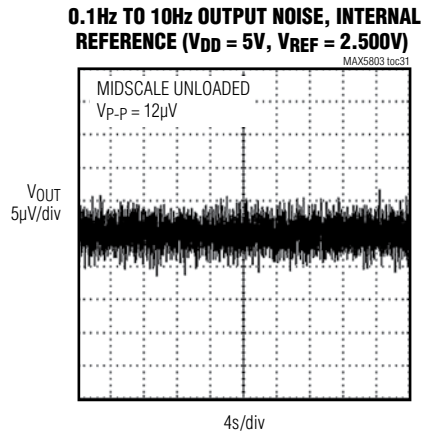

MAX5803/MAX5804/MAX5805

Ultra-Small, Single-Channel, 8-/10-/12-Bit Buffered Output Voltage DACs with Internal Reference and I²C Interface

Pin Configurations

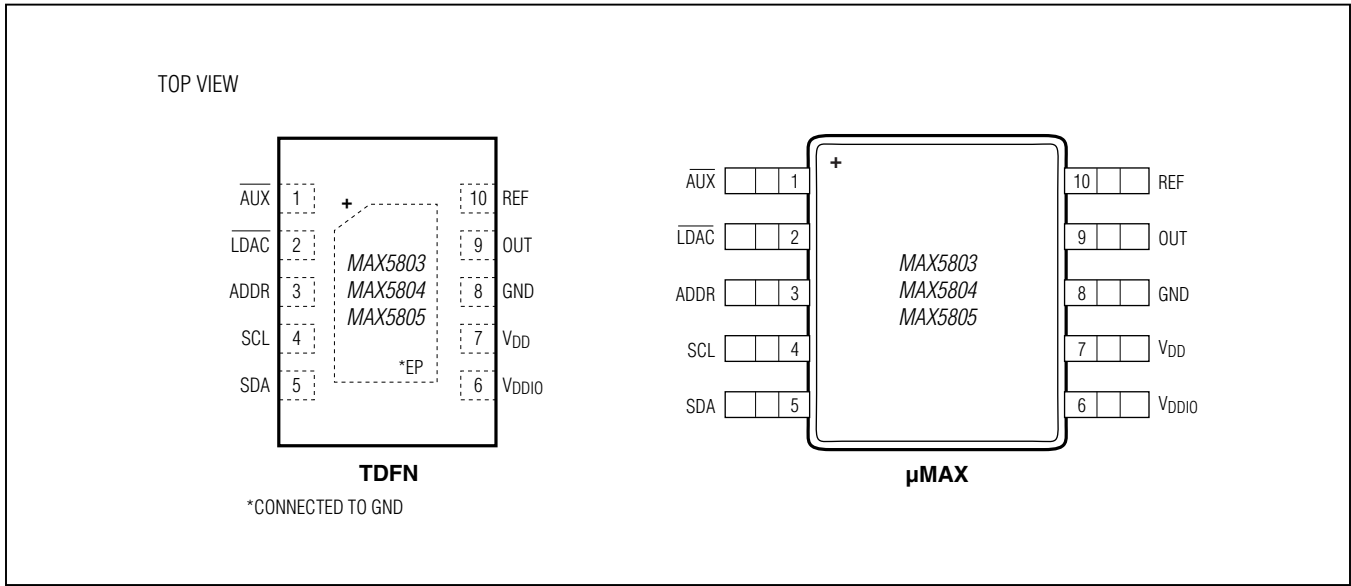

Pin Description

PIN	NAME	FUNCTION
1	$\overline{\text{AUX}}$	Active-Low Auxilliary Asynchronous Input. User Configurable, see Table 7.
2	$\overline{\text{LDAC}}$	Dedicated Active-Low Asynchronous Load DAC
3	ADDR	I ² C Interface Address Selection
4	SCL	I ² C Interface Clock Input
5	SDA	I ² C Bidirectional Serial Data
6	VDDIO	Digital Interface Power-Supply Input
7	VDD	Supply Voltage Input. Bypass VDD with a 0.1μF capacitor to GND.
8	GND	Ground
9	OUT	Buffered DAC Output
10	REF	Reference Voltage Input/Output
—	EP	Exposed Pad (TDFN Only). Connect to ground.

MAX5803/MAX5804/MAX5805

Ultra-Small, Single-Channel, 8-/10-/12-Bit Buffered Output Voltage DACs with Internal Reference and I²C Interface

Detailed Description

The MAX5803/MAX5804/MAX5805 are single-channel, low-power, 8-/10-/12-bit voltage-output digital-to-analog converters (DACs) with an internal output buffer. The wide supply voltage range of 2.7V to 5.5V and low power consumption accommodate low-power and low-voltage applications. The devices present a 100k Ω (typ) load to the external reference. The internal output buffer allows rail-to-rail operation. An internal voltage reference is available with software selectable options of 2.048V, 2.500V, or 4.096V. The devices feature a fast 400kHz I²C-compatible interface. The MAX5803/MAX5804/MAX5805 include a serial-in/parallel-out shift register, internal CODE and DAC registers, a power-on-reset (POR) circuit to initialize the DAC output to code zero, and control logic. A user-configurable $\overline{\text{AUX}}$ pin is available to asynchronously clear or gate the device output independent of the serial interface.

DAC Output (OUT)

The MAX5803/MAX5804/MAX5805 include an internal buffer on the DAC output. The internal output buffer provides improved load regulation for the DAC output. The output buffer slews at 1V/ μs (typ) and drives up to 2k Ω in parallel with 500pF. The analog supply voltage (V_{DD}) determines the maximum output voltage range of the devices as V_{DD} powers the output buffer. Under no-load conditions, the output buffer drives from GND to V_{DD} , subject to offset and gain errors. With a 2k Ω load to GND, the output buffer drives from GND to within and 200mV of V_{DD} . With a 2k Ω load to V_{DD} , the output buffer drives from V_{DD} to within 200mV of GND.

The DAC ideal output voltage is defined by:

$$V_{\text{OUT}} = V_{\text{REF}} \times \frac{D}{2^N}$$

Where D = code loaded into the DAC register, V_{REF} = reference voltage, N = resolution.

Internal Register Structure

The user interface is separated from the DAC logic to minimize digital feedthrough. Within the serial interface is an input shift register, the contents of which can be routed to control registers or the DAC itself, as determined by the user command.

Within the device there is a CODE register followed by a DAC Latch register (see the [Functional Diagram](#)).

The contents of the CODE register hold pending DAC output settings which can later be loaded into the DAC registers. The CODE register can be updated using both CODE and CODE_LOAD user commands. The contents of the DAC register hold the current DAC output settings. The DAC register can be updated directly from the serial interface using the CODE_LOAD commands or can upload the current contents of the CODE register using LOAD commands or the $\overline{\text{LDAC}}$ input.

The contents of both CODE and DAC registers are maintained during all software power-down states, so that when the DAC is returned to a normal operating mode, it returns to its previously stored output settings. Any CODE or LOAD commands issued during software power-down states continue to update the register contents. The SW_CLEAR command clears the contents of the CODE and DAC registers to the user-programmable default values. The SW_RESET command resets all configuration registers to their power-on default states, while resetting the CODE and DAC registers to zero scale.

Internal Reference

The MAX5803/MAX5804/MAX5805 include an internal precision voltage reference that is software selectable to be 2.048V, 2.500V, or 4.096V. When an internal reference is selected, that voltage is available on the REF pin for other external circuitry (see the [Typical Operating Circuits](#)) and can drive a 25k Ω load.

External Reference

The external reference input features a typical input impedance of 100k Ω and accepts an input voltage from +1.24V to V_{DD} . Connect an external voltage supply between REF and GND to apply an external reference. The MAX5803/4/5 power up and reset to external reference mode. Visit www.maximintegrated.com/products/references for a list of available external voltage-reference devices.

$\overline{\text{AUX}}$ Input

The MAX5803/MAX5804/MAX5805 provide an asynchronous $\overline{\text{AUX}}$ (active-low) input. Use the CONFIG command to program the device to use the input in one of the following modes: $\overline{\text{CLR}}$ (default), GATE, or disabled.

$\overline{\text{CLR}}$ Mode

In $\overline{\text{CLR}}$ mode, the $\overline{\text{AUX}}$ input performs an asynchronous level sensitive CLEAR operation when pulled low. If $\overline{\text{CLR}}$ is configured and asserted, all CODE and DAC

MAX5803/MAX5804/MAX5805

Ultra-Small, Single-Channel, 8-/10-/12-Bit Buffered Output Voltage DACs with Internal Reference and I²C Interface

data registers are cleared to their default/return values as defined by the configuration settings. Other user-configuration settings are not affected.

Some I²C interface commands are gated by $\overline{\text{CLR}}$ activity during the transfer sequence. If $\overline{\text{CLR}}$ is issued during a command write sequence, any gated commands within the sequence are ignored. If $\overline{\text{CLR}}$ is issued during an I²C command read sequence, the exchange continues as normal, however the data read back may be stale. The user may determine the state of the $\overline{\text{CLR}}$ input by issuing a status read. In all cases, the I²C interface continues to function according to protocol, however slave ACK pulses beyond the command acknowledge are not sent for gated write commands (notifying the μP that these instructions are being ignored). Any non-gated commands appearing in the transfer sequence are fully acknowledged and executed. In order for the gating condition to be removed, remove $\overline{\text{CLR}}$ prior to a recognized START condition, meeting t_{CLRSTA} requirements.

$\overline{\text{GATE}}$ Mode

Use of the $\overline{\text{GATE}}$ mode provides a means of momentarily holding the DAC in a user-selectable default/return state, returning the DAC to the last programmed state upon removal. The MAX5803/MAX5804/MAX5805 also feature a software-accessible GATE command. While asserted in $\overline{\text{GATE}}$ mode, the $\overline{\text{AUX}}$ pin does not interfere with RETURN, CODE, or DAC register updates and related load activity. The user may determine the gate status of the device by issuing a status read. I²C readbacks of CODE and DAC register content while gated continue to return the current register values, which may differ from the actual DAC output level.

$\overline{\text{LDAC}}$ Input

The MAX5803/MAX5804/MAX5805 provide a dedicated asynchronous $\overline{\text{LDAC}}$ (active-low) input. The $\overline{\text{LDAC}}$ input performs an asynchronous level sensitive LOAD operation when pulled low. Use of the $\overline{\text{LDAC}}$ input mode provides a means of updating multiple devices together as a group. Users wishing to control the DAC update instance independently of the I/O instruction should hold $\overline{\text{LDAC}}$ high during programming cycles. Once programming is complete, $\overline{\text{LDAC}}$ may be strobed and the new CODE register content is loaded into the DAC latch output. Users wishing to load new DAC data in direct response to I/O CODE register activity should connect $\overline{\text{LDAC}}$ permanently low; in this configuration, the MAX5803/

MAX5804/MAX5805 DAC output updates in response to each completed I/O CODE instruction update edge. A software LOAD command is also provided.

The $\overline{\text{LDAC}}$ operation does not interact with the user interface directly. However, in order to achieve the best possible glitch performance, timing with respect to the interface update edge should follow t_{LDH} specifications when issuing CODE commands. Using the software LOAD command with the Broadcast ID provides a software-based means of synchronously updating several MAX5803/MAX5804/MAX5805 devices on a shared bus.

V_{DDIO} Input

The MAX5803/MAX5804/MAX5805 feature a separate supply pin (V_{DDIO}) for the digital interface (1.8V to 5.5V). If present, connect V_{DDIO} to the I/O supply of the host processor.

I²C Serial Interface

The MAX5803/MAX5804/MAX5805 feature an I²C-/SMBus™-compatible, 2-wire serial interface consisting of a serial data line (SDA) and a serial clock line (SCL). SDA and SCL enable communication between the MAX5803/MAX5804/MAX5805 and the master at clock rates up to 400kHz. [Figure 1](#) shows the 2-wire interface timing diagram. The master generates SCL and initiates data transfer on the bus. The master device writes data to the MAX5803/MAX5804/MAX5805 by transmitting the proper slave address followed by the command byte and then the data word. Each transmit sequence is framed by a START (S) or Repeated START (Sr) condition and a STOP (P) condition. Each word transmitted to the MAX5803/MAX5804/MAX5805 is 8 bits long and is followed by an acknowledge clock pulse.

A master reading data from the MAX5803/MAX5804/MAX5805 must transmit the proper slave address followed by a series of nine SCL pulses for each byte of data requested. The MAX5803/MAX5804/MAX5805 transmit data on SDA in sync with the master-generated SCL pulses. The master acknowledges receipt of each byte of data. Each read sequence is framed by a START or Repeated START condition, a not acknowledge, and a STOP condition. SDA operates as both an input and an open-drain output. A pullup resistor, typically 4.7k Ω is required on SDA. SCL operates only as an input. A pullup resistor, typically 4.7k Ω , is required on SCL if there are multiple masters on the bus, or if the single master has an open-drain SCL output.

MAX5803/MAX5804/MAX5805

Ultra-Small, Single-Channel, 8-/10-/12-Bit Buffered Output Voltage DACs with Internal Reference and I²C Interface

Series resistors in line with SDA and SCL are optional. Series resistors protect the digital inputs of the MAX5803/MAX5804/MAX5805 from high voltage spikes on the bus lines and minimize crosstalk and undershoot of the bus signals. The MAX5803/MAX5804/MAX5805 can accommodate bus voltages higher than V_{DD} up to a limit of 5.5V; bus voltages lower than V_{DD} are not recommended and may result in significantly increased interface currents. The MAX5803/MAX5804/MAX5805 digital inputs are double buffered. Depending on the command issued through the serial interface, the CODE register(s) can be loaded without affecting the DAC register(s) using the write command. To update the DAC registers, either drive the \overline{AUX} input low while in \overline{LDAC} mode to asynchronously update the DAC output, or use the software LOAD command.

I²C START and STOP Conditions

SDA and SCL idle high when the bus is not in use. A master initiates communication by issuing a START condition on SDA with SCL high. A START condition is a high-to-low transition on SDA with SCL high. A STOP condition is a low-to-high transition on SDA while SCL is high (Figure 2). A START condition from the master signals the beginning of a transmission to the MAX5803/MAX5804/MAX5805. The master terminates transmission and frees the bus by issuing a STOP condition. The bus remains active if a Repeated START condition is generated instead of a STOP condition.

I²C Early STOP and Repeated START Conditions

The MAX5803/MAX5804/MAX5805 recognize a STOP condition at any point during data transmission except if the STOP condition occurs in the same high pulse as a START condition. Transmissions ending in an early STOP condition do not impact the internal device settings. If STOP occurs during a readback byte, the transmission is terminated and a later read mode request begins transfer of the requested register data from the beginning (this applies to combined format I²C read

mode transfers only, interface verification mode transfers will be corrupted, see Figure 2.)

I²C Slave Address

The slave address is defined as the seven most significant bits (MSBs) followed by the R/W bit. See Figure 4. The five most significant bits are 00110 with the 2 LSBs determined by ADDR as shown in Table 1. Setting the R/W bit to 1 configures the MAX5803/MAX5804/MAX5805 for read mode. Setting the R/W bit to 0 configures the MAX5803/MAX5804/MAX5805 for write mode. The slave address is the first byte of information sent to the MAX5803/MAX5804/MAX5805 after the START condition.

The MAX5803/MAX5804/MAX5805 have the ability to detect an unconnected state on the ADDR input for additional address flexibility; if leaving the ADDR input unconnected, be certain to minimize all loading on the pin (i.e. provide a landing for the pin, but do not allow any board traces). Using the ADDR input, up to three devices can be run on a single I²C bus

Table 1. I²C Slave Address LSBs

A[6:2] = 00110		
ADDR	A1	A0
V_{DD}	1	1
N.C.	1	0
GND	0	0

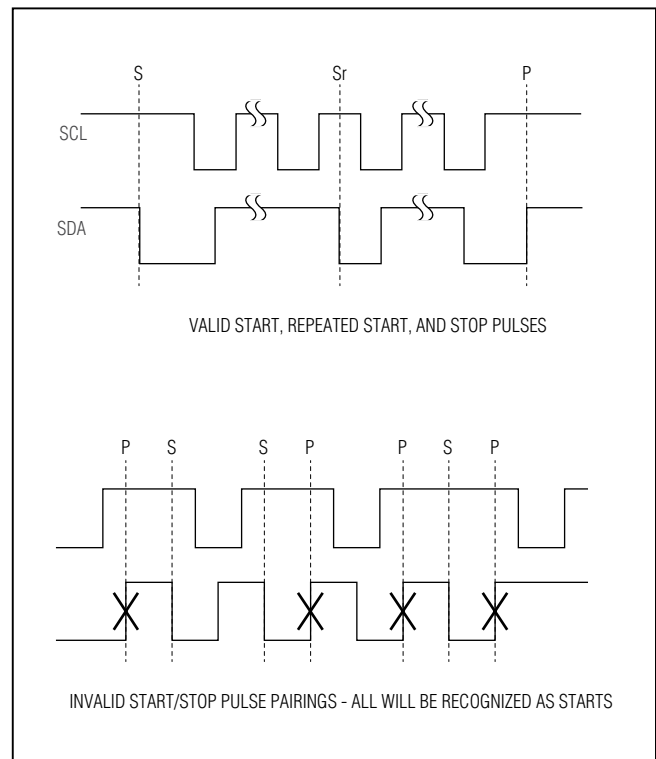

Figure 2. I²C START, Repeated START, and STOP Conditions

MAX5803/MAX5804/MAX5805

Ultra-Small, Single-Channel, 8-/10-/12-Bit Buffered Output Voltage DACs with Internal Reference and I²C Interface

I²C Broadcast Address

A broadcast address is provided for the purpose of updating or configuring all MAX5803/MAX5804/MAX5805 devices on a given I²C bus. All MAX5803/MAX5804/MAX5805 devices acknowledge and respond to the broadcast device address 00110010. The broadcast mode is intended for use in write mode only (as indicated by $R/\overline{W} = 0$ in the address given).

I²C Acknowledge

In write mode, the acknowledge bit (ACK) is a clocked 9th bit that the MAX5803/MAX5804/MAX5805 use to handshake receipt of each byte of data as shown in Figure 3. The MAX5803/MAX5804/MAX5805 pull down SDA during the entire master-generated 9th clock pulse if the previous byte is successfully received. Monitoring ACK allows for detection of unsuccessful data transfers. An unsuccessful data transfer occurs if a receiving device is busy or if a system fault has occurred. In the event of an unsuccessful data transfer, the bus master will retry communication.

In read mode, the master pulls down SDA during the 9th clock cycle to acknowledge receipt of data from the MAX5803/MAX5804/MAX5805. An acknowledge is sent by the master after each read byte to allow data transfer to continue. A not-acknowledge is sent when the master reads the final byte of data from the MAX5803/MAX5804/MAX5805, followed by a STOP condition.

I²C Command Byte and Data Bytes

A command byte follows the slave address. A command byte is typically followed by two data bytes unless it is the last byte in the transmission. If data bytes follow the command byte, the command byte indicates the address of the register that is to receive the following two data bytes. The data bytes are stored in a temporary

register and then transferred to the appropriate register during the ACK periods between bytes. This avoids any glitching or digital feedthrough to the DAC while the interface is active.

I²C Write Operations

A master device communicates with the MAX5803/MAX5804/MAX5805 by transmitting the proper slave address followed by command and data words. Each transmit sequence is framed by a START or Repeated START condition and a STOP condition as described above. Each word is 8 bits long and is always followed by an acknowledge clock (ACK) pulse as shown in Figure 4 and Figure 5. The first byte contains the address of the MAX5803/MAX5804/MAX5805 with $R/\overline{W} = 0$ to indicate a write. The second byte contains the register (or command) to be written and the third and fourth bytes contain the data to be written. By repeating the register address plus data pairs (Byte #2 through Byte #4 in Figure 4 and Figure 5), the user can perform multiple register writes using a single I²C command sequence. There is no limit as to how many registers the user can write with a single command. The MAX5803/MAX5804/MAX5805 support this capability for all user-accessible write mode commands.

Combined Format I²C Readback Operations

Each readback sequence is framed by a START or Repeated START condition and a STOP condition. Each word is 8 bits long and is followed by an acknowledge clock pulse as shown in Figure 6. The first byte contains the address of the MAX5803/MAX5804/MAX5805 with $R/\overline{W} = 0$ to indicate a write. The second byte contains the register that is to be read back. There is a Repeated START condition, followed by the device address with $R/\overline{W} = 1$ to indicate a read and an acknowledge clock. The master has control of the SCL line but the MAX5803/MAX5804/MAX5805 take over the SDA line. The final two bytes in the frame contain the register data readback followed by a STOP condition. If additional bytes beyond those required to readback the requested data are provided, the MAX5803/MAX5804/MAX5805 will continue to readback ones. Readback of the RETURN register is supported for the RETURN command ($B[23:20] = 0111$). Readback of the CODE register is supported for the CODE command ($B[23:20] = 1000$). Readback of the DAC register is supported for all LOAD commands ($B[23:20] = 1001, 1010, \text{ or } 1011$).

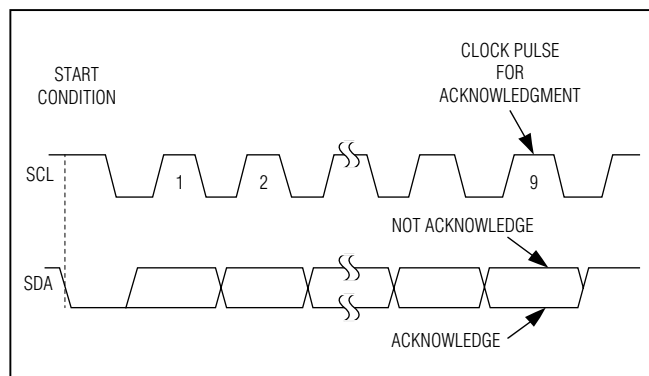

Figure 3. I²C Acknowledge

MAX5803/MAX5804/MAX5805

Ultra-Small, Single-Channel, 8-/10-/12-Bit Buffered Output Voltage DACs with Internal Reference and I²C Interface

Readback of all other registers is not directly supported. All requests to read unsupported registers read back the device's current status and configuration settings as shown in [Table 2](#). The status register contains information on the current clear, gate, and load status of the device (with a one indicating an asserted status), as well as user configuration settings for the reference, power-down, AUX mode, and default operation.

Interface Verification I²C Readback Operations

While the MAX5803/MAX5804/MAX5805 support standard I²C readback of selected registers, it is also capable of functioning in an interface verification mode. This mode is accessed any time a readback operation follows an executed write mode command. In this mode, the last executed three-byte command is read back in its entirety. This behavior allows verification of the interface.

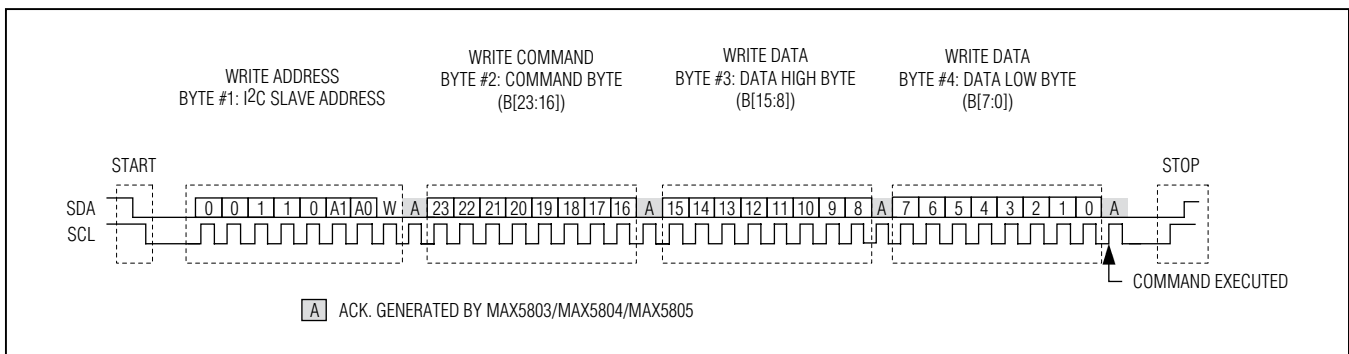

Figure 4. I²C Single Register Write Sequence

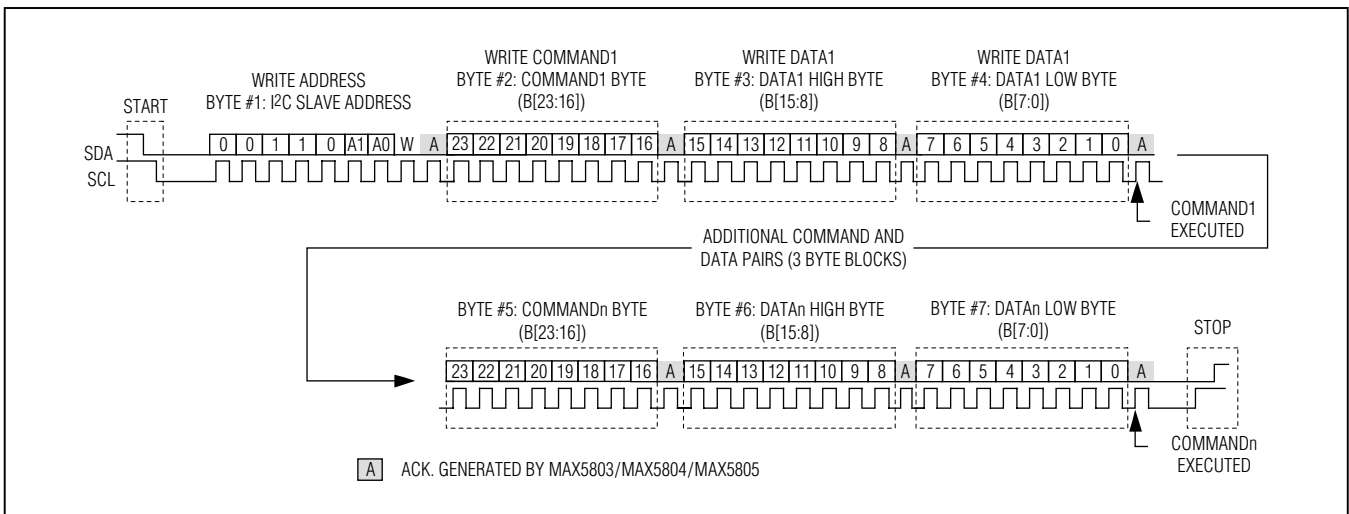

Figure 5. Multiple Register Write Sequence (Standard I²C Protocol)

MAX5803/MAX5804/MAX5805

Ultra-Small, Single-Channel, 8-/10-/12-Bit Buffered Output Voltage DACs with Internal Reference and I²C Interface

Sample command sequences are shown in Figure 7. The first command transfer is given in write mode with $R/\overline{W} = 0$ and must be run to completion to qualify for interface verification readback. There is now a STOP/START pair or Repeated START condition required, followed by the readback transfer with $R/\overline{W} = 1$ to indicate a read and an acknowledge clock from the MAX5803/MAX5804/MAX5805. The master still has control of the SCL line but the MAX5803/MAX5804/MAX5805 take over the SDA line. The final three bytes in the frame contain the command and register data written in the first transfer presented for readback, followed by a STOP condition. If additional bytes beyond those required to read back the requested

data are provided, the MAX5803/MAX5804/MAX5805 will continue to read back ones.

It is not necessary for the write and read mode transfers to occur immediately in sequence. I²C transfers involving other devices do not impact the MAX5803/MAX5804/MAX5805 readback mode. Toggling between readback modes is based on the length of the preceding write mode transfer. Combined format I²C readback operation is resumed if a write command greater than two bytes but less than four bytes is supplied. For commands written using multiple register write sequences, only the last command executed is read back. For each command written, the readback sequence can only be completed

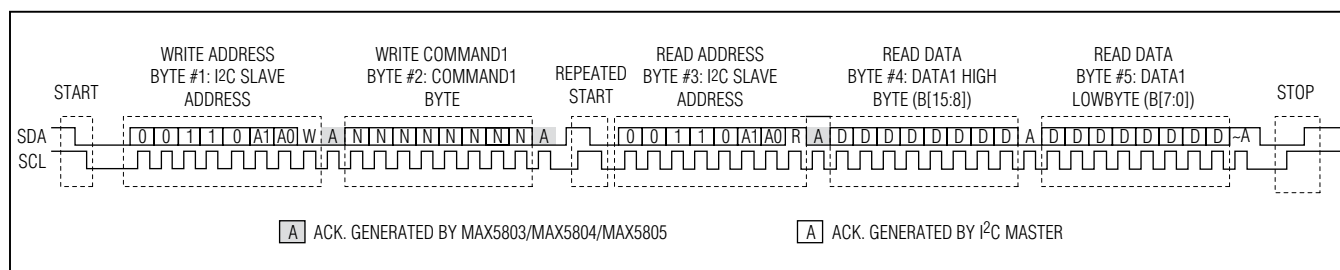

Figure 6. Standard I²C Register Read Sequence

Table 2. Standard I²C User Readback Data

COMMAND BYTE (REQUEST)								READBACK DATA HIGH BYTE								READBACK DATA LOW BYTE							
B23	B22	B21	B20	B19	B18	B17	B16	B15	B14	B13	B12	B11	B10	B9	B8	B7	B6	B5	B4	B3	B2	B1	B0
0	0	0	0	X	X	X	X	0	1	0	1	0	REV_ID[2:0] (000)		PART_ID[7:0] MAX5803 = 0x8A MAX5804 = 0x92 MAX5805 = 0x82								
0	1	1	1	X	X	X	X	RETURN[11:4]								RETURN[3:0]		0	0	0	0		
1	0	0	0	X	X	X	X	CODE[11:4]								CODE[3:0]		0	0	0	0		
1	0	0	1	X	X	X	X	DAC[11:4]								DAC[3:0]		0	0	0	0		
1	0	1	0	X	X	X	X	DAC[11:4]								DAC[3:0]		0	0	0	0		
1	0	1	1	X	X	X	X	DAC[11:4]								DAC[3:0]		0	0	0	0		
Any other command								CLR	LOAD	GATE	1	RF[3:0]			PD[1:0]		AB[2:0]		DF[2:0]				

Table 3. DAC Data Bit Positions

PART	B15	B14	B13	B12	B11	B10	B9	B8	B7	B6	B5	B4	B3	B2	B1	B0
MAX5803	D7	D6	D5	D4	D3	D2	D1	D0	X	X	X	X	X	X	X	X
MAX5804	D9	D8	D7	D6	D5	D4	D3	D2	D1	D0	X	X	X	X	X	X
MAX5805	D11	D10	D9	D8	D7	D6	D5	D4	D3	D2	D1	D0	X	X	X	X

MAX5803/MAX5804/MAX5805

Ultra-Small, Single-Channel, 8-/10-/12-Bit Buffered Output Voltage DACs with Internal Reference and I²C Interface

one time; partial and/or multiple attempts to readback executed in succession will not yield usable data.

I²C Compatibility

The MAX5803/MAX5804/MAX5805 are fully compatible with existing I²C systems. SCL and SDA are high-impedance inputs; SDA provides an open drain which pulls the data line low to transmit data or ACK pulses. [Figure 8](#) shows a typical I²C application.

I²C User-Command Register Map

This section lists the user-accessible commands and registers for the MAX5803/MAX5804/MAX5805.

[Table 4](#) provides detailed information about the I²C Command Registers.

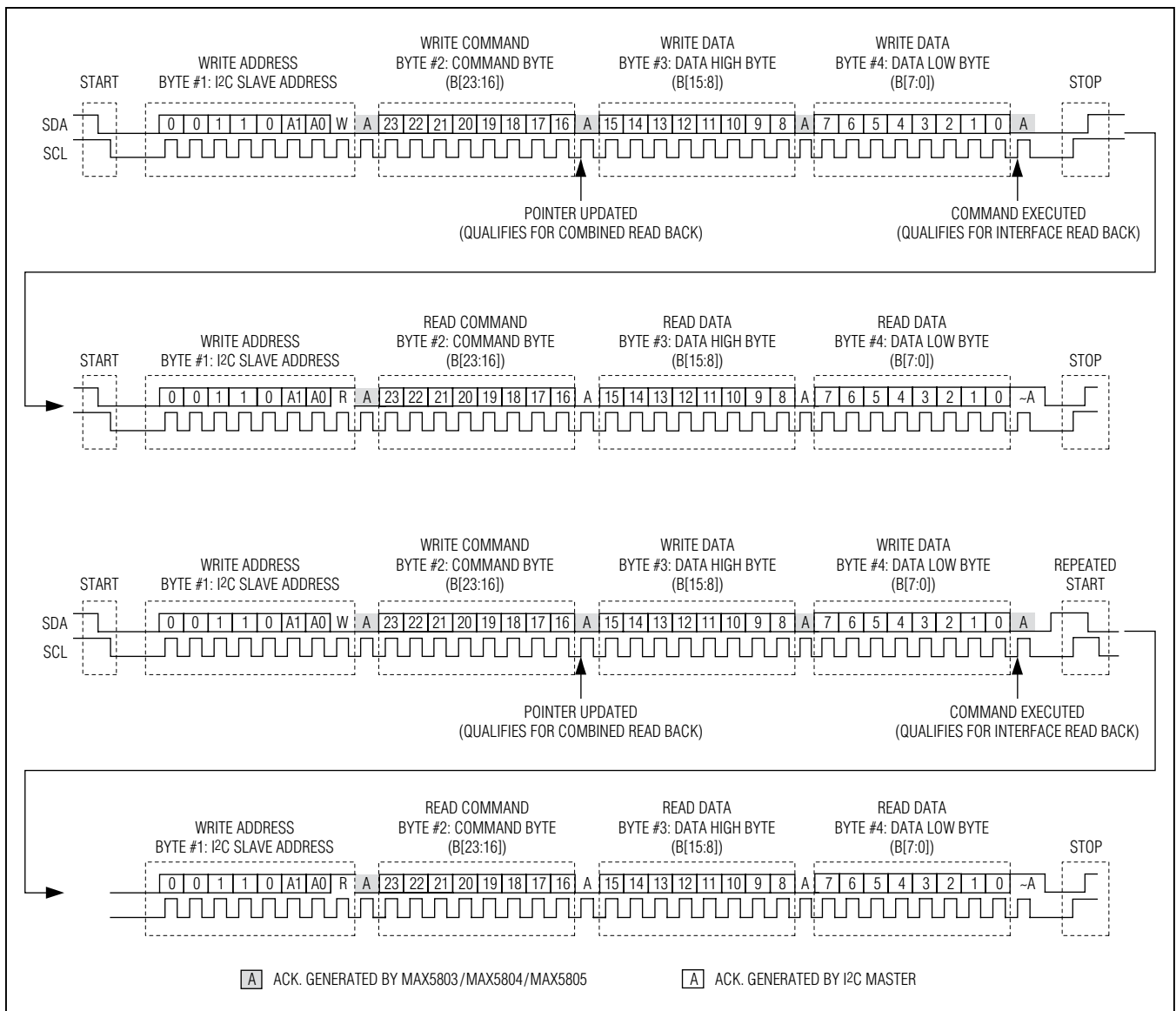

Figure 7. Interface Verification I²C Register Read Sequences

MAX5803/MAX5804/MAX5805

Ultra-Small, Single-Channel, 8-/10-/12-Bit Buffered Output Voltage DACs with Internal Reference and I²C Interface

CODE Command

The CODE command (B[23:20] = 1000) updates the CODE register content for the DAC. Changes to the CODE register content based on this command will not affect the DAC output directly unless the $\overline{\text{LDAC}}$ input is in a low state. Otherwise, a subsequent hardware or software LOAD operation will be required to move this content to the active DAC latch. This command is gated when $\overline{\text{CLR}}$ is asserted, updates to this register are ignored while the register is being cleared. See [Table 3](#) and [Table 4](#).

LOAD Command

The LOAD command (B[23:20] = 1001) updates the DAC latch register content by uploading the current contents of the CODE register. This command is gated when $\overline{\text{CLR}}$ is asserted, updates to this register are ignored while the register is being cleared. See [Table 3](#) and [Table 4](#).

CODE_LOAD Command

The CODE_LOAD command (B[23:20] = 1010 and 1011) updates the CODE register contents as well as the DAC register content of the DAC. This command is gated when $\overline{\text{CLR}}$ is asserted, updates to these registers are ignored while the register is being cleared. See [Table 3](#)

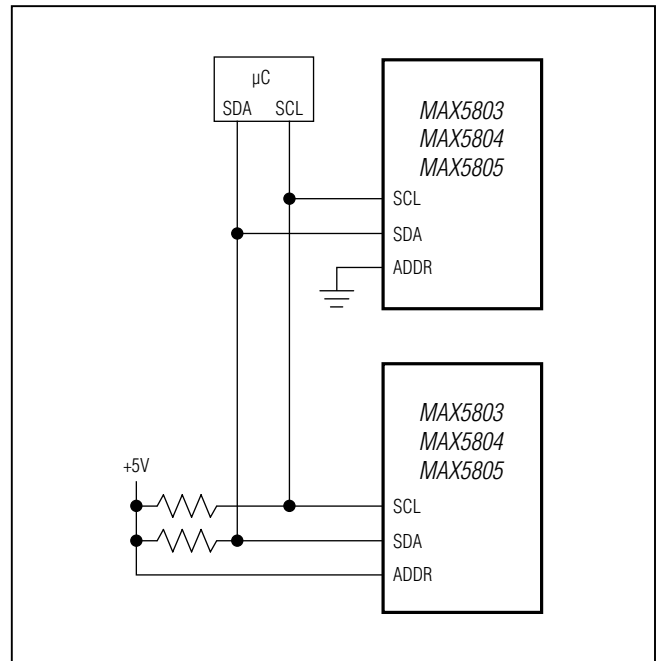

Figure 8. Typical I²C Application Circuit

MAX5803/MAX5804/MAX5805

Ultra-Small, Single-Channel, 8-/10-/12-Bit Buffered Output Voltage DACs with Internal Reference and I²C Interface

Table 4. I²C Commands Summary

COMMAND	B23	B22	B21	B20	B19	B18	B17	B16	B15	B14	B13	B12	B11	B10	B9	B8	B7	B6	B5	B4	B3	B2	B1	B0	DESCRIPTION
DAC COMMANDS																									
CODE	1	0	0	0	X	X	X	X	X	X	X	X	X	X	X	X	X	X	CODE REGISTER DATA[3:0]	X	X	X	X	X	Writes data to the CODE register
LOAD	1	0	0	1	X	X	X	X	X	X	X	X	X	X	X	X	X	X	X	X	X	X	X	X	Transfers data from the CODE registers to the DAC register
CODE_LOAD	1	0	1	0	X	X	X	X	X	X	X	X	X	X	X	X	X	X	CODE AND DAC REGISTER DATA[3:0]	X	X	X	X	X	Simultaneously writes data to the CODE register while updating DAC register
CODE_LOAD	1	0	1	1	X	X	X	X	X	X	X	X	X	X	X	X	X	X	CODE AND DAC REGISTER DATA[3:0]	X	X	X	X	X	Simultaneously writes data to the CODE register while updating DAC register
RETURN	0	1	1	1	X	X	X	X	X	X	X	X	X	X	X	X	X	X	RETURN REGISTER DATA[3:0]	X	X	X	X	X	Updates the RETURN register contents for the DAC

MAX5803/MAX5804/MAX5805

Ultra-Small, Single-Channel, 8-/10-/12-Bit Buffered Output Voltage DACs with Internal Reference and I²C Interface

Table 4. I²C Commands Summary (continued)

COMMAND	B23	B22	B21	B20	B19	B18	B17	B16	B15	B14	B13	B12	B11	B10	B9	B8	B7	B6	B5	B4	B3	B2	B1	B0	DESCRIPTION
CONFIGURATION COMMANDS																									
REF	0	0	1	0	0 = No Drive 1 = Drive Pin	0 = Default 1 = Always ON	Ref Mode 00 = EXT 01 = 2.5V 10 = 2.0V 11 = 4.1V	X	X	X	X	X	X	X	X	X	X	X	X	X	X	X	X	X	Sets the reference operating mode.
SOFTWARE	0	0	1	1	X	Type: 000 = END 001 = GATE 100 = CLR 101 = RST Other = No Effect	X	X	X	X	X	X	X	X	X	X	X	X	X	X	X	X	X	X	Executes a software operation of the type chosen
POWER	0	1	0	0	X	X	X	X	X	X	X	X	X	X	X	X	Power Mode: 00 = DAC 01 = 1kΩ 10 = 100kΩ 11 = HiZ	X	X	X	X	X	X	X	Sets the Power mode
CONFIG	0	1	0	1	X	X	X	X	X	X	X	X	X	X	X	X	AUX Mode: 011 = GATE 110 = CLEAR 111 = NONE Other = No Effect	X	X	X	X	X	X	X	Updates the function of the AUX input
DEFAULT	0	1	1	0	X	X	X	X	X	X	X	X	X	X	X	X	Default Values: 000 = POR 001 = ZERO 010 = MID 011 = FULL 100 = RETURN Other = No Effect	X	X	X	X	X	X	X	Sets the default value for the DAC
NO OPERATION COMMANDS																									
No Operation	0	0	0	0	X	X	X	X	X	X	X	X	X	X	X	X	X	X	X	X	X	X	X	X	These commands will have no effect on the part.
Reserved Commands: Any commands not specifically listed above are reserved for Maxim internal use only.																									

MAX5803/MAX5804/MAX5805

Ultra-Small, Single-Channel, 8-/10-/12-Bit Buffered Output Voltage DACs with Internal Reference and I²C Interface

REF Command

The REF (B[23:20] = 0010) command updates the global reference setting used for the DAC. Set B[17:16] = 00 to use an external reference for the DAC or set B[17:16] to 01, 10, or 11 to select either the 2.5V, 2.048V, or 4.096V internal reference, respectively.

If RF3 (B19) is set to zero (default) in the REF command, the REF I/O will not be driven by the internal reference circuit, saving current. If RF3 is set to one, the REF I/O will be driven by the internal reference circuit, consuming an additional 25µA (typ) of current when the reference is powered; when the reference is powered down, the REF I/O will be high-impedance.

If RF2 (B18) is set to zero (default) in the REF command, the reference will be powered down any time the DAC is powered down (in STANDBY mode). If RF2 (B18) is set to one, the reference will remain powered even if the DAC is powered down, allowing continued operation of external circuitry. In this mode, the 1µA shutdown state is not available. See [Table 5](#).

SOFTWARE Commands

The SOFTWARE (B[23:20] = 0011) commands provide a means of issuing several flexible software actions. See [Table 6](#).

The SOFTWARE Command Action Mode is selected by B[18:16]:

- END (000): Used to end any active gate operation, returning to normal operation (default).
- GATE (001): DAC contents will be gated to their DEFAULT selected values until the gate condition is removed.
- CLEAR (100): All CODE and DAC contents will be cleared to their DEFAULT selected values.
- RESET (101): All CODE, DAC, RETURN, and configuration registers reset to their power-up defaults (including REF, POWER, and CONFIG settings), simulating a power cycle reset.
- OTHER: No effect.

Table 5. REF (0010) Command Format

B23	B22	B21	B20	B19	B18	B17	B16	B15	B14	B13	B12	B11	B10	B9	B8	B7	B6	B5	B4	B3	B2	B1	B0
0	0	1	0	RF3	RF2	RF1	RF0	X	X	X	X	X	X	X	X	X	X	X	X	X	X	X	X
REF COMMAND				0 = REF Not Driven 1 = REF Driven	0 = Off in Standby 1 = On in Standby	Ref Mode: 00 = EXT 01 = 2.5V 10 = 2.0V 11 = 4.0V				Don't Care						Don't Care							
DEFAULT VALUES				0	0	0	0	X	X	X	X	X	X	X	X	X	X	X	X	X	X	X	X
COMMAND BYTE								DATA HIGH BYTE								DATA LOW BYTE							

Table 6. SOFTWARE (0011) Command Format

B23	B22	B21	B20	B19	B18	B17	B16	B15	B14	B13	B12	B11	B10	B9	B8	B7	B6	B5	B4	B3	B2	B1	B0
0	0	1	1	X	SW2	SW1	SW0	X	X	X	X	X	X	X	X	X	X	X	X	X	X	X	X
SOFTWARE COMMANDS				Don't Care	Mode: 000: END 001: GATE 100: CLR 101: RST Other: No Effect			Don't Care						Don't Care									
DEFAULT VALUES				X	0	0	0	X	X	X	X	X	X	X	X	X	X	X	X	X	X	X	X
COMMAND BYTE								DATA HIGH BYTE								DATA LOW BYTE							

MAX5803/MAX5804/MAX5805

Ultra-Small, Single-Channel, 8-/10-/12-Bit Buffered Output Voltage DACs with Internal Reference and I²C Interface

POWER Command

The MAX5803/MAX5804/MAX5805 feature a software-controlled POWER mode command (B[23:20] = 0100).

In power-down, the DAC output is disconnected from the buffer and is grounded with either one of the two selectable internal resistors or set to high impedance. See [Table 7](#) and [Table 8](#) for the selectable internal resistor values in power-down mode. In power-down

mode, the DAC register retains its value so that the output is restored when the device powers up. The serial interface remains active in power-down mode with all registers accessible.

In power-down mode, the internal reference can be powered down or it can be set to remain powered-on for external use. Also, in power-down mode, parts using the external reference do not load the REF pin. See [Table 7](#).

Table 7. POWER (0100) Command Format

B23	B22	B21	B20	B19	B18	B17	B16	B15	B14	B13	B12	B11	B10	B9	B8	B7	B6	B5	B4	B3	B2	B1	B0	
0	1	0	0	X	X	X	X	X	X	X	X	X	X	X	X	PD1	PD0	X	X	X	X	X	X	
POWER COMMAND				Don't Care				Don't Care								Power Mode: 00 = Normal 01 = 1kΩ 10 = 100kΩ 11 = Hi-Z		Don't Care						
DEFAULT VALUES				X	X	X	X	X	X	X	X	X	X	X	X	X	0	0	X	X	X	X	X	X
COMMAND BYTE								DATA HIGH BYTE								DATA LOW BYTE								

Table 8. Selectable DAC Output Impedance in Power-Down Mode

PD1 (B7)	PD0 (B6)	OPERATING MODE
0	0	Normal operation
0	1	Power-down with internal 1kΩ pulldown resistor to GND.
1	0	Power-down with internal 100kΩ pulldown resistor to GND.
1	1	Power-down with high-impedance output.

MAX5803/MAX5804/MAX5805

Ultra-Small, Single-Channel, 8-/10-/12-Bit Buffered Output Voltage DACs with Internal Reference and I²C Interface

CONFIG Command

The CONFIG command (B[23:20] = 0101) updates the function of the $\overline{\text{AUX}}$ input enabling its gate or clear (default) operation mode. See [Table 9](#).

$\overline{\text{AUX}}$ Config settings are written by B[5:3]:

- GATE (011): $\overline{\text{AUX}}$ functions as a $\overline{\text{GATE}}$. DAC code is gated to DEFAULT value input when pin is low.
- CLEAR (110): $\overline{\text{AUX}}$ functions as a $\overline{\text{CLR}}$ input (default). CODE and DAC content is cleared to DEFAULT value if pin is low.
- NONE (111): $\overline{\text{AUX}}$ functions are disabled.
- OTHER: $\overline{\text{AUX}}$ function is not altered.

DEFAULT Command

DEFAULT (0110): The DEFAULT command selects the default value for the DAC. These default values are used for all future clear and gate operations. The new default setting is determined by bits DF[2:0]. See [Table 10](#).

Available default values are:

- POR (000): DAC defaults to power-on reset value (default).
- ZERO (001): DAC defaults to zero scale.
- MID (010): DAC defaults to midscale.
- FULL (011): DAC defaults to full scale.
- RETURN (100): DAC defaults to value specified by the RETURN register
- OTHER: No effect, the default setting remains unchanged.

Note: The selected default values do not apply to resets initiated by SW_RESET commands or supply cycling, both of which return the DACs to the power-on reset state (zero scale).

Table 9. CONFIG (0101) Command Format

B23	B22	B21	B20	B19	B18	B17	B16	B15	B14	B13	B12	B11	B10	B9	B8	B7	B6	B5	B4	B3	B2	B1	B0	
0	1	0	1	X	X	X	X	X	X	X	X	X	X	X	X	X	X	AB2	AB1	AB0	X	X	X	
CONFIG COMMAND				Don't Care				Don't Care								Don't Care		AUXB Mode: 011 = GATE 110 = CLEAR 111 = NONE Other = No Effect			Don't Care			
DEFAULT VALUES				X	X	X	X	X	X	X	X	X	X	X	X	X	X	X	1	1	0	X	X	X
COMMAND BYTE								DATA HIGH BYTE								DATA LOW BYTE								

Table 10. DEFAULT (0110) Command Format

B23	B22	B21	B20	B19	B18	B17	B16	B15	B14	B13	B12	B11	B10	B9	B8	B7	B6	B5	B4	B3	B2	B1	B0	
0	1	1	0	X	X	X	X	X	X	X	X	X	X	X	X	DF2	DF1	DF0	X	X	X	X	X	
DEFAULT COMMAND				Don't Care				Don't Care								Default Values: 000: POR 001: ZERO 010: MID 011: FULL 100: RETURN Other: No Effect			Don't Care					
DEFAULT VALUES				X	X	X	X	X	X	X	X	X	X	X	X	X	0	0	0	X	X	X	X	X
COMMAND BYTE								DATA HIGH BYTE								DATA LOW BYTE								

MAX5803/MAX5804/MAX5805

Ultra-Small, Single-Channel, 8-/10-/12-Bit Buffered Output Voltage DACs with Internal Reference and I²C Interface

RETURN Command

The RETURN command (B[23:20] = 0111) updates the RETURN register content for the DAC. If the DEFAULT configuration register is set to RETURN mode, the DAC will be cleared or gated to the RETURN register value in the event of a SW or HW CLEAR or GATE condition. It is not necessary to program this register if the DEFAULT = RETURN mode will not be used. The data format for the RETURN register is identical to that used for CODE and LOAD operations. See [Table 3](#) and [Table 4](#).

Applications Information

Power-On Reset (POR)

When power is applied to V_{DD}, the DAC output is set to zero scale. To optimize DAC linearity, wait until the supplies have settled and the internal setup and calibration sequence completes (200µs, typ).

Power Supplies and Bypassing Considerations

Bypass V_{DD} with high-quality ceramic capacitors to a low-impedance ground as close as possible to the device. Minimize lead lengths to reduce lead inductance. Connect GND to the analog ground plane.

Layout Considerations

Digital and AC transient signals on GND can create noise at the output. Connect GND to form the star ground for the DAC system. Refer remote DAC loads to this system ground for the best possible performance. Use proper grounding techniques, such as a multilayer board with a low-inductance ground plane, or star connect all ground return paths back to the MAX5803/MAX5804/MAX5805 GND. Carefully layout the traces between channels to reduce AC cross-coupling. Do not use wire-wrapped boards and sockets. Use shielding to maximize noise immunity. Do not run analog and digital signals parallel to one another, especially clock signals. Avoid routing digital lines underneath the MAX5803/MAX5804/MAX5805 package.

Definitions

Integral Nonlinearity (INL)

INL is the deviation of the measured transfer function from a straight line drawn between two codes once offset and gain errors have been nullified.

Differential Nonlinearity (DNL)

DNL is the difference between an actual step height and the ideal value of 1 LSB. If the magnitude of the DNL ≤ 1 LSB, the DAC guarantees no missing codes and is monotonic. If the magnitude of the DNL ≥ 1 LSB, the DAC output may still be monotonic.

Offset Error

Offset error indicates how well the actual transfer function matches the ideal transfer function. The offset error is calculated from two measurements near zero code and near maximum code.

Gain Error

Gain error is the difference between the ideal and the actual full-scale output voltage on the transfer curve, after nullifying the offset error. This error alters the slope of the transfer function and corresponds to the same percentage error in each step.

Zero-Scale Error

Zero-scale error is the difference between the DAC output voltage when set to code zero and ground. This includes offset and other die level nonidealities.

Full-Scale Error

Full-scale error is the difference between the DAC output voltage when set to full scale and the reference voltage. This includes offset, gain error, and other die level nonidealities.

Settling Time

The settling time is the amount of time required from the start of a transition, until the DAC output settles to the new output value within the converter's specified accuracy.

Digital Feedthrough

Digital feedthrough is the amount of noise that appears on the DAC output when the DAC digital control lines are toggled.

Digital-to-Analog Glitch Impulse

A major carry transition occurs at the midscale point where the MSB changes from low to high and all other bits change from high to low, or where the MSB changes from high to low and all other bits change from low to high. The duration of the magnitude of the switching glitch during a major carry transition is referred to as the digital-to-analog glitch impulse.

The digital-to-analog power-up glitch is the duration of the magnitude of the switching glitch that occurs as the device exits power-down mode.

MAX5803/MAX5804/MAX5805

Ultra-Small, Single-Channel, 8-/10-/12-Bit Buffered Output Voltage DACs with Internal Reference and I²C Interface

Typical Operating Circuits

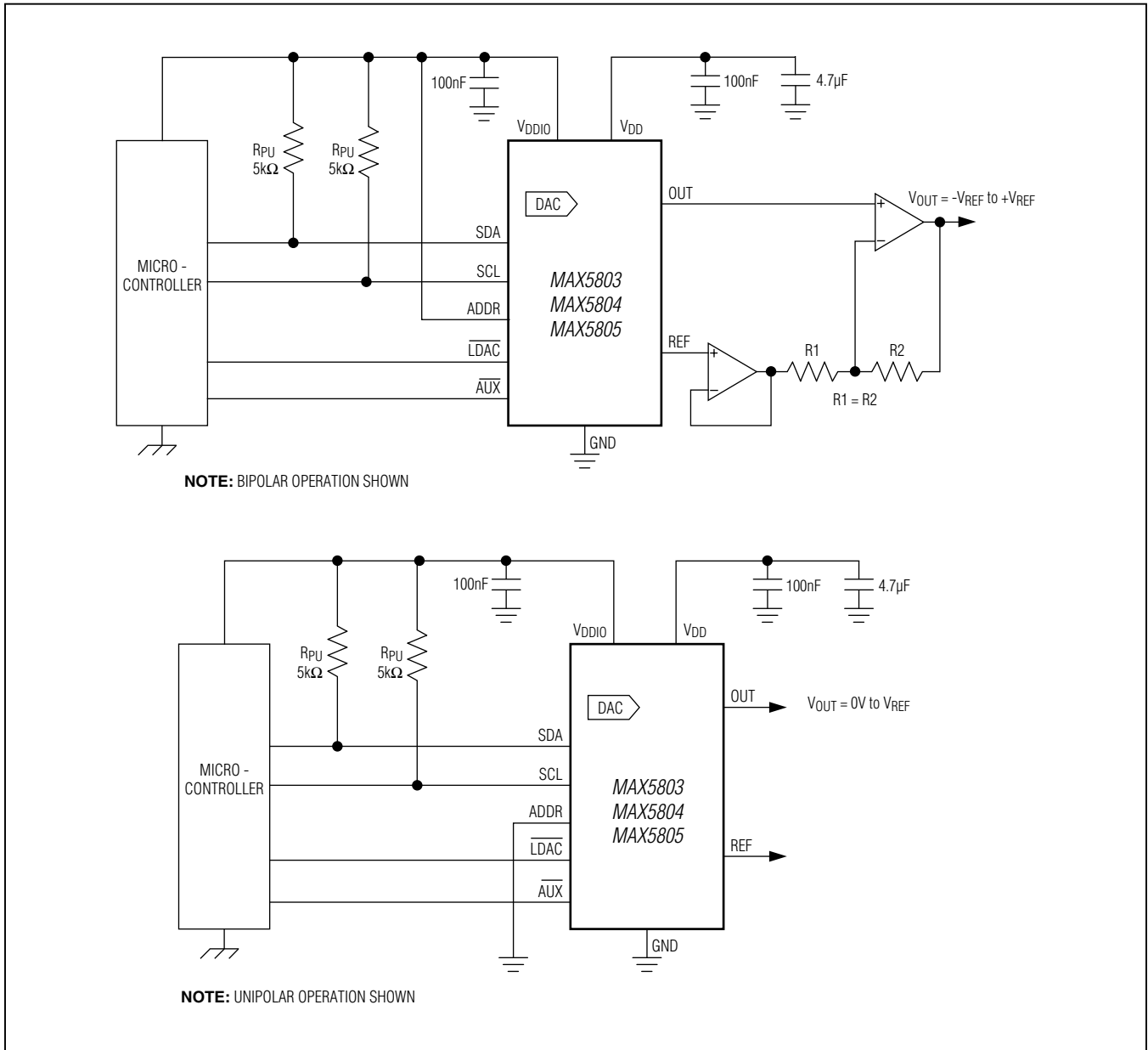

MAX5803/MAX5804/MAX5805

Ultra-Small, Single-Channel, 8-/10-/12-Bit Buffered Output Voltage DACs with Internal Reference and I²C Interface

Ordering Information

PART	PIN-PACKAGE	RESOLUTION (BIT)	INTERNAL REFERENCE TEMPCO (ppm/°C)
MAX5803ATB+T*	10 TDFN-EP**	8	10 (typ), 25 (max)
MAX5803AUB+	10 μMAX	8	10 (typ), 25 (max)
MAX5804ATB+T*	10 TDFN-EP**	10	10 (typ), 25 (max)
MAX5804AUB+	10 μMAX	10	10 (typ), 25 (max)
MAX5805AAUB+	10 μMAX	12	4 (typ), 12 (max)
MAX5805BATB+T*	10 TDFN-EP**	12	10 (typ), 25 (max)
MAX5805BAUB+	10 μMAX	12	10 (typ), 25 (max)

Note: All devices are specified over the -40°C to +125°C temperature range.

+Denotes a lead(Pb)-free/RoHS-compliant package.

T = Tape and reel.

*Future product—Contact factory for availability.

Chip Information

PROCESS: BiCMOS

Package Information

For the latest package outline information and land patterns (footprints), go to www.maximintegrated.com/packages. Note that a "+", "#", or "-" in the package code indicates RoHS status only. Package drawings may show a different suffix character, but the drawing pertains to the package regardless of RoHS status.

PACKAGE TYPE	PACKAGE CODE	OUTLINE NO.	LAND PATTERN NO.
10 TDFN-EP	T1032N+1	21-0429	90-0082
10 μMAX	U10+2	21-0061	90-0330

MAX5803/MAX5804/MAX5805

Ultra-Small, Single-Channel, 8-/10-/12-Bit Buffered Output Voltage DACs with Internal Reference and I²C Interface

Revision History

REVISION NUMBER	REVISION DATE	DESCRIPTION	PAGES CHANGED
0	11/12	Initial release	—
1	2/13	Released the MAX5703/MAX5704. Updated the <i>Electrical Characteristics</i> .	2–8, 30



Maxim Integrated cannot assume responsibility for use of any circuitry other than circuitry entirely embodied in a Maxim Integrated product. No circuit patent licenses are implied. Maxim Integrated reserves the right to change the circuitry and specifications without notice at any time. The parametric values (min and max limits) shown in the Electrical Characteristics table are guaranteed. Other parametric values quoted in this data sheet are provided for guidance.

Maxim Integrated 160 Rio Robles, San Jose, CA 95134 USA 1-408-601-1000

31

© 2013 Maxim Integrated Products, Inc.

Maxim Integrated and the Maxim Integrated logo are trademarks of Maxim Integrated Products, Inc.