

General Description

This preliminary specification provides a general guideline on the performance and the integration of W2CBW009Di, a complete wireless subsystem featuring full 802.11 b/g WLAN + BT capabilities in a small form factor module solution. Both radios are fully tested for coexistence, both internally and with other external radio technologies. A full menu of certifications will also be provided. Based on world-class silicon from Wi2Wi partner Marvell, the W2CBW009Di has also been fully optimized for throughput and receive sensitivity through careful design practices. State-of-the art software development resources are also available to create drivers for unique processors and operating systems if needed.

Features

- Compact design for easy integration: 16mm x 16mm
- 76 pin module
- Bluetooth & WLAN technology is based on Marvell's 88W8688
- Optimized RF and electrical design for better performance in co-existence with other wireless standards
- Operates in 2.4 GHz ISM band
- WEP, WPA, WPA2 (WiFi Protected Access)
- ROHS Compliant
- Fully integrated coexistence solution
- Industrial Temperature Range
- For Dual Antenna application

Applications

- Warehousing and Logistics Handhelds
- Automotive Aftermarket
- Medical Equipment
- Industrial Handhelds
- Defense
- MIDs, UMPCs and Netbooks
- M2M Applications
- POS Terminals
- Internet-Enabled Consumer Devices
- VoFi and Other Smart Phones
- WiFi Enabled Security Cameras

Target Specifications

- Package Dimensions
16mm x 16mm
- Power Ratings
200mA
- Temperature Range
-40C to +85C
- Interfaces - WiFi
SDIO, GSPI
- Interfaces - BT
UART
- Transmit Power
WiFi up to 15dBm
BT up to 10dBm
(Higher than Class 2)

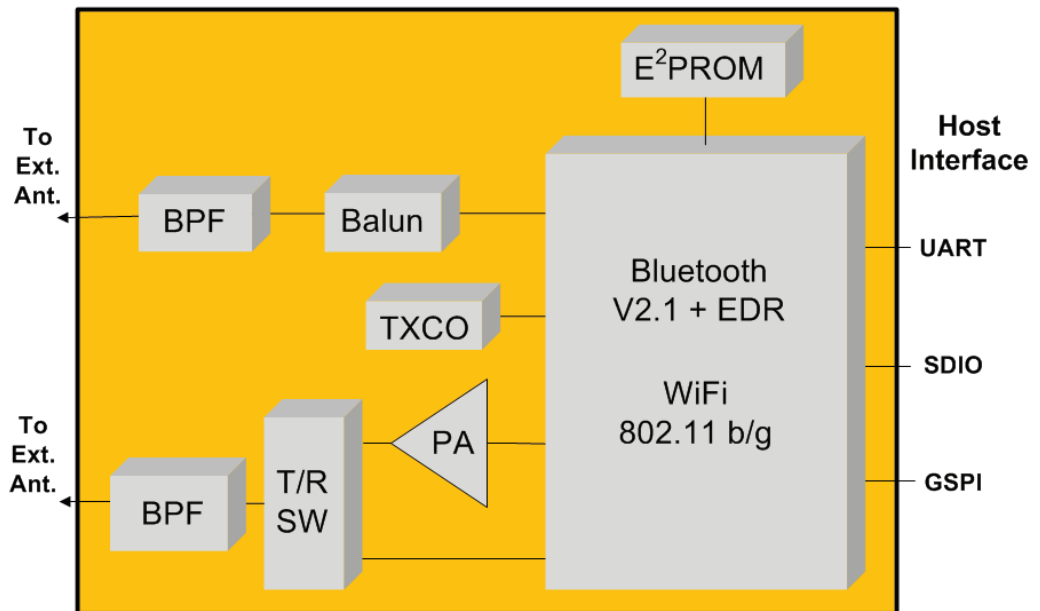

The preliminary specification is intended for advance information only, and is subject to change without notification.