

SX-PCEAN

802.11 a/b/g/n PCI Express Card Module



Robust & Highly integrated 2 stream 11n solution

Wireless Solutions from the Experts in Embedded Wireless

The SX-PCEAN is an IEEE 802.11 a/b/g/n compliant 2.4/5 GHz dual band PCI Express Half-Mini Card. Designed for the growing demand of PCIe compliant devices that require wireless connectivity in a small form factor combined with high data throughput.

The SX-PCEAN features two stream MIMO technology and 40 MHz band width mode with throughput up to 300 Mbps. Unlike the other similar solutions, the design, manufacturing, and tuning processes are strictly controlled in-house at the Silex state-of-the-art ISO9001 facility in Japan.

Each card is individually tested and inspected to ensure the industry's highest quality resulting greater performance and reliability. The SX-PCEAN is designed to meet the demanding performance requirements of critical embedded applications.

Silex Advanced Services

As a Qualcomm Atheros Authorized Design Center (ADC), Silex Technology America has the experience and expertise to provide all of the services necessary to enable embedded wireless networking in virtually any type product.

We specialize in embedded wireless solutions and services.

Our products and services include:

- Wireless Cards such as Mini-PCI, PCI Express and SDIO cards
- Intelligent wireless modules with Linux OS, robust protocols, web interface and enterprise security
- Wireless System in Package (SiP) for highly integrated applications
- Custom wireless module design and manufacturing
- Driver development and porting
- Certification, Manufacturing, and Logistics

In addition, Silex Technology America can engage with customers to execute a Qualcomm Atheros NDA which allows access to Qualcomm Atheros documentation and source code.

Key Features:

- Qualcomm Atheros AR9280 highly integrated chip set
- IEEE 802.11a/b/g/n compliant 2.4/5 GHz dual band
- Full MIMO performance with data rate up to 300 Mbps
- PCI Express Half-Mini Card compliant
- PCI Express Mini Card 1.2 compliant
- Driver offering includes Linux, Windows 7 and Embedded XP
- Linux supplicant available for WPA/WPA2-PSK & 802.1x EAP
- Custom Driver development available
- IEEE 802.11e QOS support

Benefits:

- Small form factor based by Industry's highest quality
- Robust proprietary Linux/Windows driver
- Wide range of wireless security options available

Target Applications:

Medical devices, Security Systems, Industrial, PoS, Digital Signs, Set-Top/ Net-Top Box, Embedded / Industrial / Tablet PC, Handheld devices, Thin Client devices, virtually any device supporting PCI Express interface.

Specifications:

Product Name	SX-PCEAN
Chipset	Qualcomm Atheros AR9280
Antenna Connector	U.FL Connector
Operating Voltage	3.3V +/- 10%
Power Consumption	TX: 810mA (Max), RX: 220A (Max)
Weight	4.5g
Dimensions	30.0 x 26.8 x 4.5 mm, PCB Thickness = 1.0 mm
Storage Conditions	Temperature: -20 - 85C, Humidity: 10 - 85% RH
Operating Conditions	Temperature: 0 - 60C, Humidity: 20 - 80% RH

Dimensions and Architecture

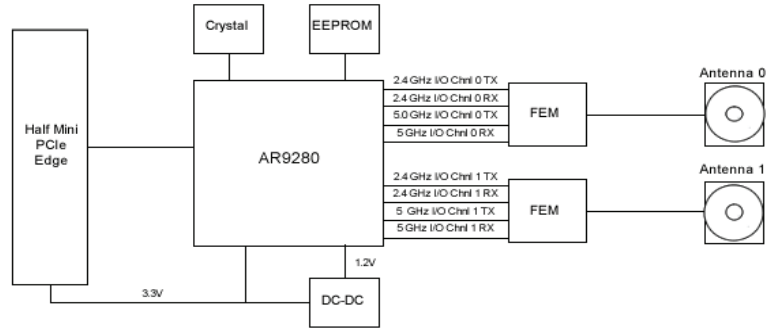
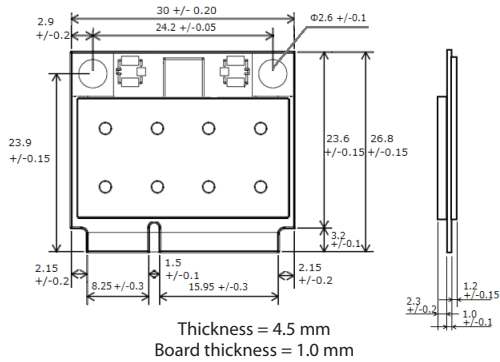

Radio Configuration & General Specifications

Center Frequency:

802.11a, na HT20	5180 - 5825 MHz
802.11na HT40	5190 - 5795 MHz
802.11b, g, ng HT20	2412 - 2472 (Ch. 1 - 13)
802.11ng HT40	2422 - 2462 (Ch. 3 - 11)

Channel Spacing:

802.11a, na HT20	20 MHz
802.11b, g, ng HT20/HT40	5 MHz
802.11na HT40	40 MHz

Modulation Type:

802.11a, na	OFDM (64QAM, 16QAM, QPSK, BPSK)
802.11b	DSSS (CCK, DQPSK, DBPSK)
802.11g, ng	DSSS-OFDM (64QAM, 16QAM, QPSK, BPSK)

Driver Support

Silex Linux Reference Driver:

- 802.11a/b/g/n supported
- Ad hoc, Infrastructure, Access Point mode

Silex WPA Software:

- WPA Supplicant (Station) / WPA Authenticator (AP)
- Customized based on Open Source WPA supplicant / hostapd
- WPA - TKIP/AES - PSK/EAP(TLS/TTLS/PEAP/FAST)
- WPA2 - AES - PSK/EAP (TLS/TTLS/PEAP/FAST)
- IEEE 802.1X - WEP / None - EAP (TLS/TTLS/PEAP/FAST)

Windows Embedded (Windows XP/Windows 7)

Standard Compliance

Device Interfaces:

- IEEE802.11a/b/g/n/e/h/i
- PCI Express Mini Card v1.2
(Single definitions: PCI Express v1.1)

Regulatory:

- Japan Radio Law Rule Article 2 Section 1 Number 19
- Japan Radio Law Rule Article 2 Section 1 Number 19-3
- Japan Radio Law Rule Article 2 Section 1 Number 19-3-2
- FCC Part15 (Subpart C, Subpart E)
- IC RSS (210, Gen)
- EU R&TTE Directive (EN300 328, EN301 893)

Recommended Antenna:

The following antenna part has been qualified for TELEC;
Part Number: TD17027A350 di-pole antenna (1.5 dBi @ 2.4 GHz)
(2.1 dBi @ 5.825 GHz)
Vendor: Sansel Electronic

Ordering Information

SX-PCEAN(P) +
Individually Packaged, 2 Antennas & Cables, MAC & EMI Labels
SX-PCEAN-BBNL +
Bulk Packaged, MAC Address Label Only

silex technology is a registered trademark of silex technology, Inc. Other product or brand names may be registered trademarks or trademarks of their respective owners. Technical information and specifications are subject to change without notice. © 2012 silex technology, Inc. All rights reserved.

silex global sales & support locations