

RS-XMEGA-220X Datasheet

Redpine Signals, Inc.

2107 N. First Street, #680

San Jose, CA 95131.

Tel: (408) 748-3385

Fax: (408) 705-2019

Email: info@redpinesignals.com

Website: www.redpinesignals.com

Overview

Overview

The RS-XMEGA-220x- is a IEEE 802.11bgn based Wi-Fi add-on card that can be interfaced with Atmel's XMEGA-A3BU kit. It integrates a MAC, baseband processor, RF transceiver with power amplifier, a frequency reference, and an antenna in hardware; and all WLAN protocol and configuration functionality, networking stack in embedded firmware to make a fully self-contained 802.11n WLAN connectivity solution for a variety of applications.

Device Features:

- Compliant to 802.11b/g and single stream 802.11n
- Fully self-contained serial-to-wireless functionality
- Supports WPA2-PSK, WEP (64 and 128 bit) and TKIP security in infrastructure mode
- Supports WEP (64 and 128 bit) security in ad-hoc mode
- Terminates TCP and UDP connections
- Configuration through UART
- Integrated antenna, frequency reference.
- Ultra-low-power operation with power-save modes
- Ad-hoc and infrastructure modes for maximum deployment flexibility
- Single supply – 3.1 to 3.6V operation

RS-XMEGA-220X System Block Diagram

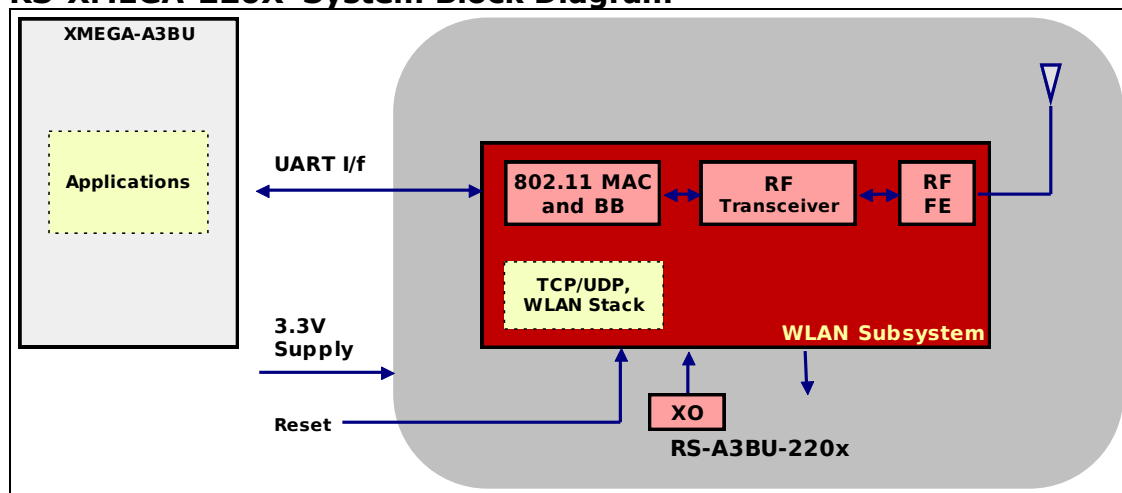

RS-RS-UC3L0-220X System Block Diagram

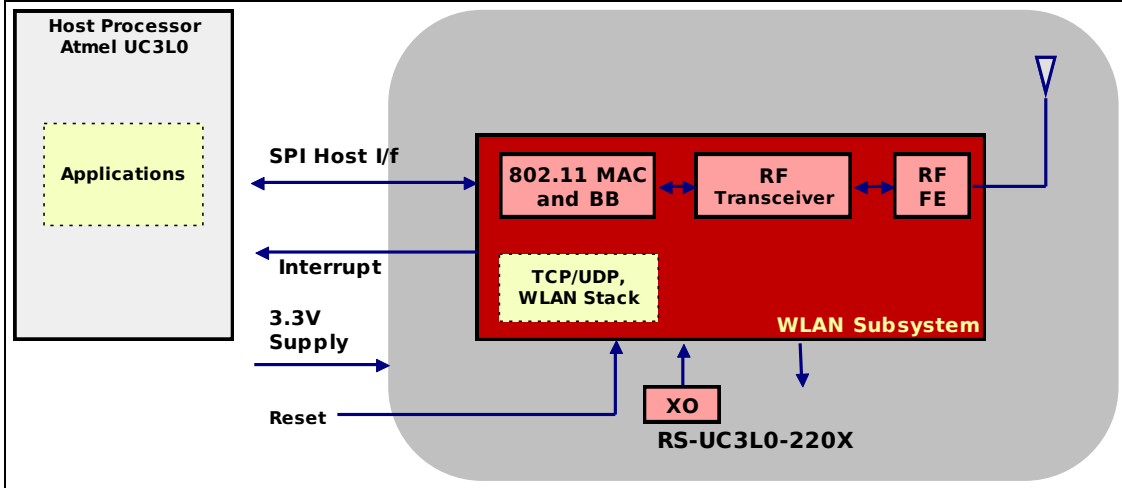

Table of Contents

1	Detailed Feature List.....	7
1.1	Host Interface	7
1.2	WLAN	7
1.3	Networking Protocols	7
1.4	Configuration.....	8
1.5	Software.....	8
2	Package Description	9
2.1	Top View	9
3	UART Interface Pin Description	10
3.1	Pin Description	11
4	Electrical Characteristics	12
4.1	Recommended Operating Conditions.....	12
4.2	Characteristics – Digital I/O Signals.....	12
5	Performance Specifications	13
5.1	Wireless Specifications	13
5.2	Receive Sensitivity.....	13
6	Software Architecture Overview	14
6.1	Host	15
6.1.1	UART	15
6.1.2	RS-XMEGA-220X	15
6.1.3	UART	15
6.1.4	Host Abstraction Layer (HAL)	15
6.1.5	Wireless Control Block (WCB).....	15
6.1.6	Wi-Fi Control Frames	15
6.1.7	TCP/IP Control Frames	15
6.1.8	Station Management Entity (SME)	15
6.1.9	WPA Supplicant.....	16
7	Creating Custom Hardware Designs.....	17
8	Ordering Information	18
8.1	Contact Information	18
8.2	Resources included with RS-XMEGA-220X	18

Table of Figures

Figure 1: Top View of the Module	9
Figure 2: Pinout of the UART Connector	10
Figure 3: Software Architecture Block Diagram.....	14

List of Tables

Table 1: Pin Description	11
Table 2: Recommended Operating Conditions	12
Table 3: Input/Output DC Characteristics	12
Table 4: Wireless Specifications	13
Table 5: Receive Characteristics – Sensitivity	13

1 Detailed Feature List

1.1 Host Interface

- UART
 - The UART forms the physical layer of the TCP/IP stack carrying SLIP-encapsulated frames
 - The UART interface supports standard baud rates from 9600 to 3686400 bps
 - AT Command Interface for configuration and operating the module

1.2 WLAN

MAC

- Conforms to IEEE 802.11b/g/n standards
- Dynamic selection of fragment threshold, data rate, and antenna depending on the channel statistics
- Hardware accelerated implementation of WEP 64/128-bit and AES
- Infrastructure and Ad-hoc modes
- Security - WPA2-PSK, WEP, WPA-TKIP

Baseband Processing

- Supports DSSS (1, 2 Mbps) and CCK (5.5, 11 Mbps) modes
- Supports all OFDM data rates (6, 9, 12, 18, 24, 36, 48, and 54 Mbps)
- Supports IEEE 802.11n single-stream modes with data rates up to 65 Mbps
- Supports long, short, and HT preamble modes
- High-performance multipath compensation in OFDM, DSSS, and CCK modes

RF

- Highly integrated 2.4 GHz transceiver and Power Amplifier with direct conversion architecture
- Integrated frequency reference and antenna

1.3 Networking Protocols

- TCP
- UDP
- ARP
- ICMP
- DHCP Client

1.4 Configuration

The RS-XMEGA-220X module can be configured by the Host using the UART interface. The following are some of the commands that can be given to the module:

- Scan
- Connect
- Pre-shared Keys
- SSID of hidden WLAN networks
- DHCP Enable/Disable
- Create/Join an IBSS (ad-hoc) network
- Open/Close sockets for TCP, UDP

1.5 Software

- Host driver for UART interface
- Device configuration and management GUI for Windows XP
- Embedded firmware for complete WLAN functionality.

2 Package Description

2.1 Top View

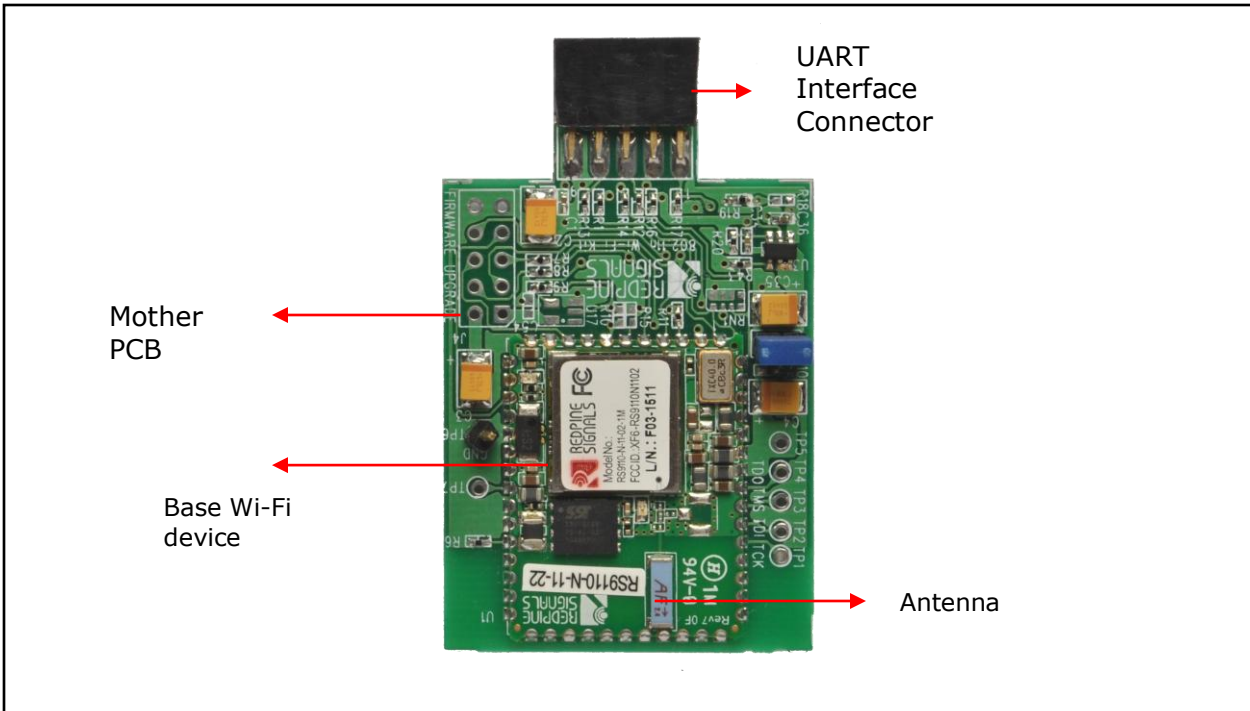

Figure 1:Top View of the Module

Note: The base Wi-Fi device is a Redpine Signals 802.11n module (RS9110-N-11-22-01, http://redpinesignals.com/Products/Modules/Connect-io-n/Wireless_Device_Server/RS9110-N-11-22.html) that is put on the mother PCB above to create the Wi-Fi add-on card.

3 UART Interface Pin Description

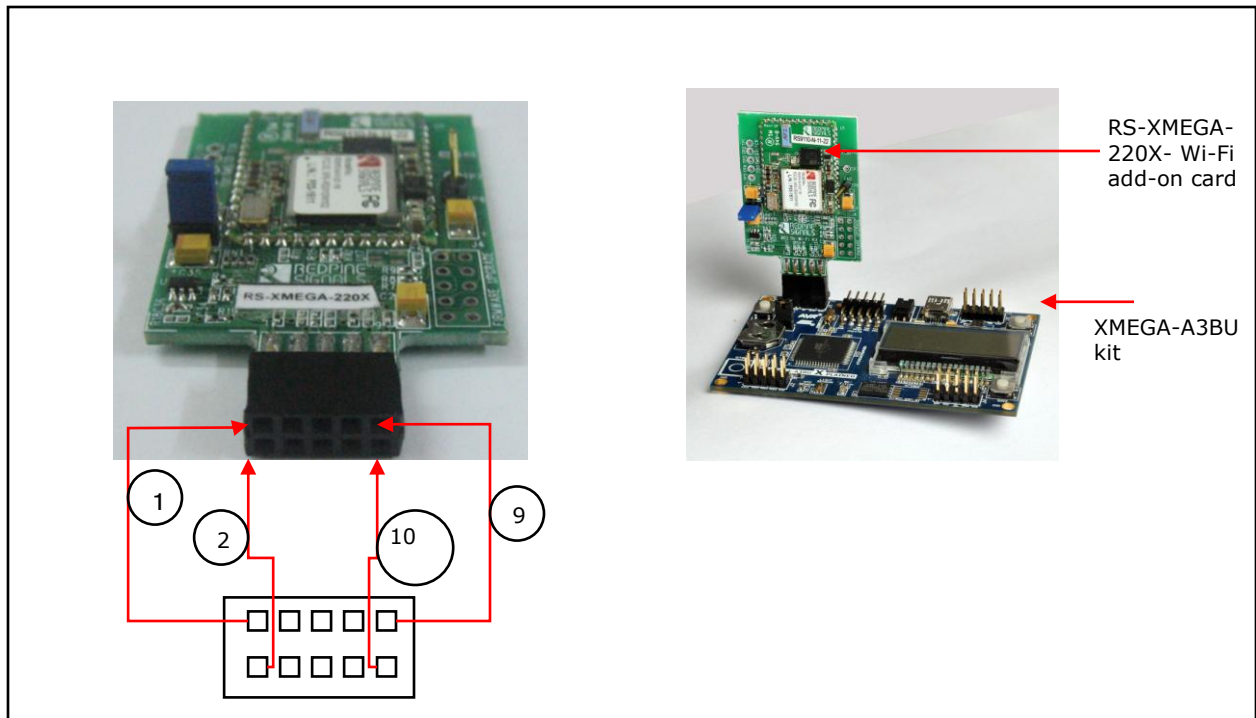

Figure 2: Pinout of the UART Connector

Note: For detailed description about the Kit , please visit www.atmel.com

3.1 Pin Description

Pin No.	Pin Name	Direction	Description
1	RESET_n	Input	Active Low reset input driving the reset of the Wi-Fi module
2	POWER_EN	Input	Driven from the XMEGA-A3BU Kit, enables power to the Wi-Fi add-on card.
3	UART_IN	Input	Data Input for UART
4	UART_OUT	Output	Data Output for UART
5	Reserved	-	No connect
6	Reserved	-	No connect
7	Reserved	-	No connect
8	Reserved	-	No connect
9	GND	Input	Should be connected to Ground
10	VCC	Input	To be connected to 3.3V Supply

Table 1: Pin Description

4 Electrical Characteristics

4.1 Recommended Operating Conditions

Parameter	Symbol	Min.	Typ.	Max.	Units
Input Supply voltage	V_{IN}	3.1	3.3	3.6	V
Ambient temperature	T_a	-40	25	85	°C

Table 2: Recommended Operating Conditions

4.2 Characteristics – Digital I/O Signals

Parameter	Min.	Typ.	Max.	Units
Input high voltage	2	-	3.6	V
Input low voltage	-0.3	-	0.8	V
Output low voltage	-	-	0.4	V
Output high voltage	3.0	-	-	V
Input leakage current (at 3.3V or 0V)	-	-	±10	μA
Tristate output leakage current (at 3.3V or 0V)	-	-	±10	μA

Table 3: Input/Output DC Characteristics

5 Performance Specifications

5.1 Wireless Specifications

Feature	Description
Frequency Band	2.400 – 2.500 GHz (2.4 GHz ISM band)
Modulation	OFDM with BPSK, QPSK, 16-QAM, and 64-QAM 802.11b with CCK and DSSS
Supported Data Rates	802.11n: 6.5, 13, 19.5, 26, 39, 52, 58.5, 65 Mbps 802.11a/g: 6, 9, 12, 18, 24, 36, 48, 54 Mbps 802.11b: 1, 2, 5.5, 11 Mbps
802.11n Features	MCS 0-7, STBC, RIFS, Greenfield Protection A-MPDU, A-MSDU Aggregation with Block-ack
Typical Transmit Power (+/- 2 dBm)	17 dBm for 802.11b DSSS 17 dBm for 802.11b CCK 15 dBm for 802.11g/n OFDM

Table 4: Wireless Specifications

5.2 Receive Sensitivity

Data Rate	Typical Sensitivity (+/- 1.5 dBm)	Sweep – PER Floor
1 Mbps	-97.0 dBm	< 0.1%
2 Mbps	-93.0 dBm	< 0.1%
11 Mbps	-88.0 dBm	< 0.1%
6 Mbps	-91.0 dBm	< 0.1%
54 Mbps	-75.0 dBm	< 0.1%
65 Mbps	-71.0 dBm	< 0.1%

Table 5: Receive Characteristics – Sensitivity

6 Software Architecture Overview

The following figure depicts the software architecture of the RS-XMEGA-220X module.

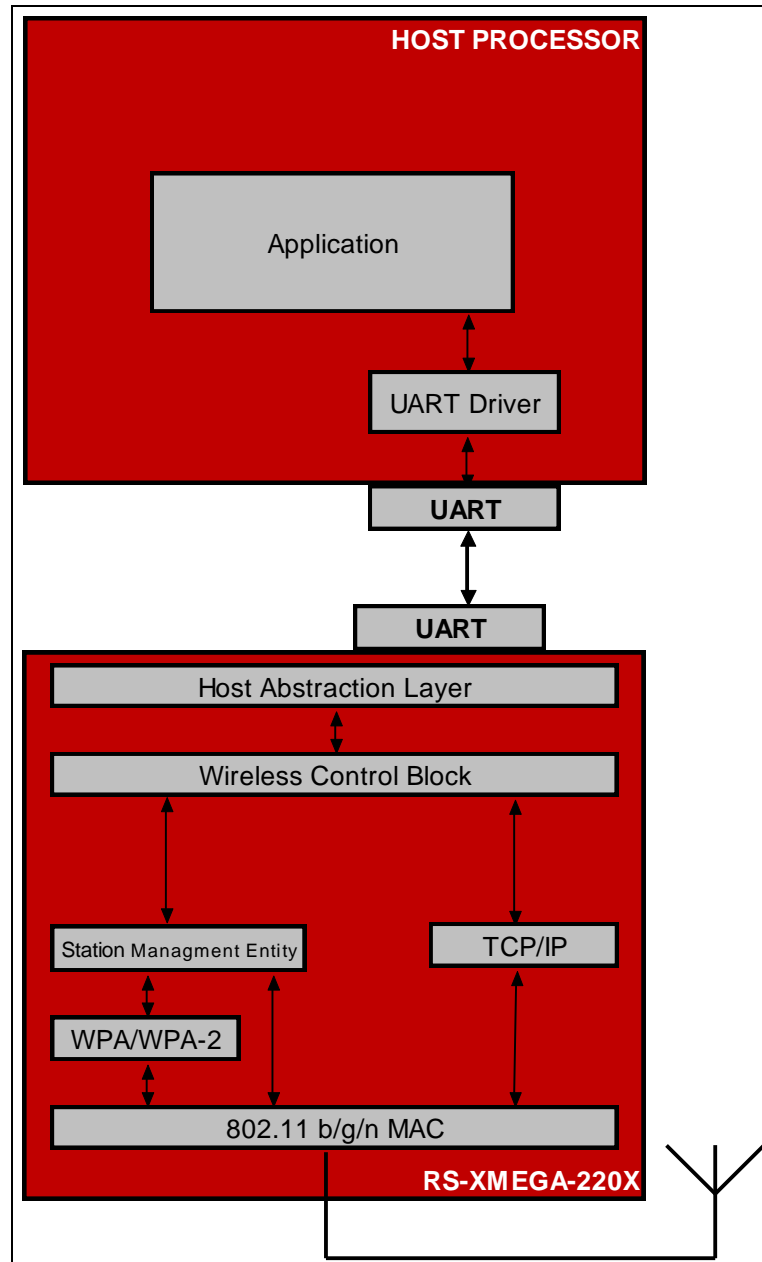

Figure 3: Software Architecture Block Diagram

The Host communicates with RS-XMEGA-220X using the UART interface.

The following sections explain in brief the various components.

6.1 Host

The Host is any system that has applications being executed on it and configures and operates the Wi-Fi module.

6.1.1.1 UART

The UART on the Host side provides an interface for the host to access the Wi-Fi module. UART is used to configure various parameters of the RS-XMEGA-220X module and also to send and receive data over the network by accessing the TCP/IP stack in the module.

6.1.2 RS-XMEGA-220X

6.1.2.1 UART

The UART on the RS-XMEGA-220X module is the physical interface which transmits/receives the data from the Host. It supports variable baud rates from 9600 to 3686400 bps. There is support for AT commands to configure and operate the module through UART interface.

6.1.2.2 Host Abstraction Layer (HAL)

The HAL abstracts the lower layers in the host interface with which the RS-XMEGA-220X module is connected. The HAL interacts with the Wireless Control Block layer for the processing of the frames obtained from or destined to the Host.

6.1.2.3 Wireless Control Block (WCB)

The data from/to the Host is classified as Wi-Fi specific frames and TCP/IP specific frames. The WCB layer processes the frame obtained and acts accordingly. The functionality of the WCB module depends on the type of the frame and the direction of the frame (in case of TCP/IP) as described below.

6.1.2.4 Wi-Fi Control Frames

The WCB interprets the Wi-Fi control information from the Host and interacts with the SME (Station Management Entity). Configuration of the RS-XMEGA-A3BU-220X module from the Host for Wi-Fi access is through AT commands.

6.1.2.5 TCP/IP Control Frames

If the frames from the host are interpreted as TCP/IP specific frames then the WCB interacts with the TCP/IP stack.

6.1.2.6 Station Management Entity (SME)

The SME is the core layer which manages the Wi-Fi connectivity. The SME maintains the state machine to detect the activity on the Wi-Fi network and indicates to the user accordingly. It also performs re-association to the configured access point in Infrastructure mode. It interacts with the WPA supplicant if Security is enabled in the Wi-Fi network.

6.1.2.7 WPA Supplicant

The WPA supplicant is used to initiate the 802.1x/E Access Point authentication if WPA/WPA2-PSK is used as the security parameter. It also plays a major part in performing the 4-way handshake to derive the PTK in WPA/WPA2-PSK modes.

7 Creating Custom Hardware Designs

The base Wi-Fi device shown in the figure [Top View of the Module](#) is a Redpine Signals 802.11n module (Part no. RS9110-N-11-22, http://redpinesignals.com/Products/Modules/Connect-io-n/Wireless_Device_Server/RS9110-N-11-22.html). The Wi-Fi module is put on the mother PCB above to create the Wi-Fi add-on card. This module can be added as a Wi-Fi component in any other custom designs using the RS9110-N-11-22 module and the Atmel XMEGA-A3BU Host processor. For guidance on integrating the module on an application board, please visit <http://www.redpinesignals.com/Products/Modules/Connect-io-n/index.html>.

8 Ordering Information

8.1 Contact Information

For additional information, please contact Sales at Redpine Signals, Inc.

Redpine Signals, Inc.

2107 North First Street, Suite 680,

San Jose, CA 95131 USA

Phone: +1 408 748 3385

E-mail: sales@redpinesignals.com

Website: <http://www.redpinesignals.com/atmel>

8.2 Resources included with RS-XMEGA-220X

The following documentation and software are available along with the RS-XMEGA-220X, downloadable from www.redpinesignals.com/atmel.

Documentation

- Wi-Fi add-on card datasheet
- Getting Started Guide
- Programming Reference Manual
- Application notes for example applications

Software

- GUI for demonstration application
- Binary image for demonstration application
- API Source Code

Source code for example application