

WizFi210/220 User Manual

(Version 1.01)



©2011 WIZnet Co., Ltd. All Rights Reserved.

☞ For more information, visit our website at <http://www.wiznet.co.kr>

Certification Information

CE for Class B ITE

INFORMATION TO THE USER

Hereby, WIZnet. Declares that this WizFi210 is in compliance with the essential requirements and other relevant provisions of directive 1999/5/EC.

WARNING: This is a class B product. In a domestic environment this product may cause radio interference in which case the user may be required to take adequate measures.

FCC for Class B ITE

INFORMATION TO THE USER

This equipment has been tested and found to comply with the limits for a Class B digital device, pursuant to part 15 of the FCC Rules. These limits are designed to provide reasonable protection against harmful interference in a residential installation. This equipment generates, uses and can radiate radio frequency energy and, if not installed and used in accordance with the instructions, may cause harmful interference to radio communications. However, there is no Guarantee that interference will not occur in a particular installation. If this equipment does cause harmful interference to radio or television reception, which can be determined by turning the equipment off and on, the user is encouraged to try to correct the interference by one more of the following measures:

- Reorient or relocate the receiving antenna.
- Increase the separation between the equipment and receiver.
- Connect the equipment into an outlet on a circuit different from that to which the receiver is connected.
- Consult the dealer or an experienced radio/TV technician for help.

WARNING: This equipment may generate or use radio frequency energy. Changes or modifications to this equipment may cause harmful interference unless the modifications are expressly approved in the instruction manual. The user could lose the authority to operate this equipment if an unauthorized change or modification is made.

KC for Class B ITE

INFORMATION TO THE USER

This equipment has been tested for a Class B digital device.

- Trade Name or Applicant : WIZnet, Co., Ltd.
- Equipment Name : Wireless LAN Module
- Model Number : WizFi210
- Manufacturer / Country of Origin : WIZnet, Co., Ltd. / KOREA
- Certification Number : KCC-CRM-WWW-WIZFI210

WARNING: This equipment may generate or use radio frequency energy. Changes or modifications to this equipment may cause harmful interference.

Document Revision History

Date	Revision	Changes
2011-03-24	V1.0	Official Release
2011-05-24	V1.01	Changed Power Consumption and RF Output Power Added Auto Reconnect AT Command(AT+XAR) Added Certification Information

<Contents>

1. Overview	1
(1) Benefits and Features	2
(2) Specifications.....	3
2. Hardware Specification	4
(1) Operating Conditions	4
(2) Digital Input Specifications	4
(3) Digital Output Specifications	4
(4) I/O Digital Specification (Tri-State).....	5
(5) RTC Input Specifications	6
(6) RTC Output Specifications	6
(7) Internal 1.8V regulator.....	7
(8) Power Consumption (VDDRTC=VDD=3.3V, VDDIO=1.8V, Temp=25°C).....	7
(9) Power Consumption (VDDRTC=VDD=3.3V, VDDIO=3.3V, Temp=25°C).....	8
(10) RF Specification	9
(11) Block Diagram	10
(12) Pin Description	11
(13) Module Dimension	15
(14) Recommend Pad Dimension.....	16
(15) LED Indications	17
(16) Application Circuit	18
(17) Interface	20
3. Application Guide	21
(1) AP Scanning	21
(2) Network Connection Management.....	21
(3) Auto Connection Operation.....	21
(4) Response Codes	22
(5) Use of GPIO10	23
(6) AT Command example	24
4. AT Commands	25
(1) Command interface	25
(2) UART / adapter interface configuration.....	25
(3) Profile management	26
(4) Wi-Fi interface	27
(5) Wi-Fi security.....	27
(6) Wireless configuration	29
(7) Network interface	29
(8) Connection management	30
(9) Battery check.....	31
(10) Power state management.....	31
(11) Auto connection	31
(12) Provisioning	32
(13) Miscellaneous	32
5. Warranty	34

<Table>

TABLE 1. SPECIFICATIONS	3
TABLE 2. OPERATING CONDITIONS	4
TABLE 3. DIGITAL INPUT SPECIFICATIONS	4
TABLE 4. DIGITAL OUTPUT SPECIFICATIONS	4
TABLE 5. I/O DIGITAL SPECIFICATION	5
TABLE 6. RTC INPUT SPECIFICATIONS	6
TABLE 7. RTC OUTPUT SPECIFICATIONS	6
TABLE 8. INTERNAL 1.8V REGULATOR	7
TABLE 9. POWER CONSUMPTION	7
TABLE 10. RF SPECIFICATION	9
TABLE 11. PIN DESCRIPTION	14
TABLE 12. LED INDICATIONS	17
TABLE 13. RESPONSE CODES	23
TABLE 14. AT COMMAND EXAMPLE	24
TABLE 15. COMMAND INTERFACE	25
TABLE 16. UART / ADAPTER INTERFACE CONFIGURATION	26
TABLE 17. PROFILE MANAGEMENT	26
TABLE 18. WI-FI INTERFACE	27
TABLE 19. WI-FI SECURITY	28
TABLE 20. WIRELESS CONFIGURATION	29
TABLE 21. NETWORK INTERFACE	29
TABLE 22. CONNECTION MANAGEMENT	31
TABLE 23. BATTERY CHECK	31
TABLE 24. POWER STATE MANAGEMENT	31
TABLE 25. AUTO CONNECTION	32
TABLE 26. PROVISIONING	32
TABLE 27. MISCELLANEOUS	33

<Figure>

FIGURE 1. BASIC DIAGRAM	1
FIGURE 2. BLOCK DIAGRAM.....	10
FIGURE 3. PIN DESCRIPTION.....	11
FIGURE 4. MODULE DIMENSION.....	15
FIGURE 5. RECOMMEND PAD DIMENSION	16
FIGURE 6. V_{IN} = BATTERY, STANDBY SUPPORT	18
FIGURE 7. V_{IN} = AC ADAPTOR, STANDBY SUPPORT.....	18
FIGURE 8. AC ADAPTOR, ALWAYS ON.....	19
FIGURE 8. FIRMWARE DOWNLOAD.....	19
FIGURE 9. INTERFACE	20
FIGURE 10. FACTORY DEFAULT AND AD HOC MODE	23

1. Overview

The WizFi210 family of fully certified modules offers a quick, easy, and cost effective way for device and appliance manufacturers to add Wi-Fi capabilities to their products. The module provides serial UART interface which enables connection to any embedded design utilizing an 8/16/32-bit microcontroller via simple commands. The WizFi210 is an ideal solution for organizations with limited or no Wi-Fi or RF expertise, as it not only dramatically reduces RF design time but also removes the burden of testing and certification; allowing customers to focus on their core application, product, or expertise. The module supports data rates up to 11 Mbps, and is compliant with 802.11b.

The WizFi210 provides customers the mean to evaluate the capabilities of ultra-low power wireless system-on-a-chip and the Serial to Wi-Fi embedded software for Wi-Fi networks. The Serial to Wi-Fi embedded software allows devices and appliance manufacturers to easily add Wi-Fi capabilities to their products with minor impact on the host microcontroller firmware.

The WizFi210 provides all the hardware and software necessary to quickly set up a serial (UART) based link to a PC or external microcontroller.

The WizFi220 is a RF-enhanced Product. Except for [RF Output Power], the WizFi220 is similar in management and development to the WizFi210. In other words, the WizFi220 will consume more power but it has the improved WiFi range.

(All documents for the WizFi210 apply to the WizFi220)

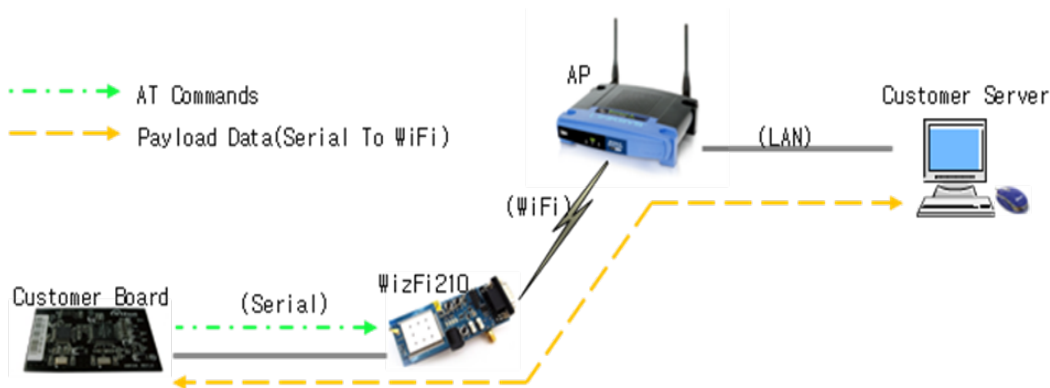

Figure 1. Basic Diagram

(1) Benefits and Features

- Brings Wi-Fi connectivity to any device with a microcontroller and serial HOST interface (UART)
- Minimal Serial to Wi-Fi "driver" footprint on host microcontroller and minor changes to existing host MCU firmware
- Offloading of smaller host microcontrollers from the Wi-Fi and TCP/ IP networking
- Simple AT commands for configuration and data communication
- DHCP/Static IP, TCP/UDP, Server/Client, DNS
- Reduces development time, testing and certification burden, accelerating time to market
- Easy device provisioning through our utility or Wi-Fi Protected Set-up (WPS)
- Ultra low power consumption through dynamic power management
- Operates with standard 802.11 b/g/n access points at speed up to 11 Mbps (802.11b)
- 802.11i Security (WEP, WPA, WPA2-PSK, Enterprise)
- Rich I/O interfaces (SPI, UART, GPIO, I2C, ADC, JTAG)
- Low power modes, Alarm Input for wake-up
- High-throughput hardware AES and RC4 encryption/decryption engines

(2) Specifications

Specifications	Description
Radio Protocol	IEEE 802.11b/g/n Compatible
Supported Data Rates	11, 5.5, 2, 1 Mbps (802.11 b)
Modulation	DSSS and CCK
RF Operating Frequency	2.4 - 2.497 GHz
Antenna Options	Chip antenna and U.FL connector for external antenna
Networking Protocols	UDP, TCP/IP (IPv4), DHCP, ARP, DNS, HTTP/HTTPS Client and Server(*)
Power Consumption (Typical)	Standby = 34.0 μ A(WizFi210), TBD (WizFi220) Receive = 125.0 mA(WizFi210), TBD (WizFi220) Transmit = 135.0 mA(WizFi210), TBD (WizFi220)
RF Output Power (Typical)	8 \pm 1 dBm (WizFi210) TBD (WizFi220)
Security Protocols	WEP, WPA/WPA2 – PSK, Enterprise, EAP-FAST, EAP-TLS, EAP-TTLS, PEAP
I/O Interface	UART, SPI(*), I2C(*), WAKE, ALARM, GPIOs
Power Source	3.3V
Dimensions	32 x 23.5 x 3 mm

Table 1. Specifications

(*) is supported by software customizing.

2. Hardware Specification

(1) Operating Conditions

	Min	Typ	Max	Unit
Operating Ambient Range	-40		+85	°C
RTC Supply Voltage	1.2	3.3	3.6	V
Single Supply Voltage	3.0	3.3	3.6	V

Table 2. Operating Conditions

(2) Digital Input Specifications

	Min	Typ	Max	Unit
IO Supply Voltage	1.62/3	1.8/3.3	1.98/3.63	V
Input Low Voltage (V_{IL})	-0.3		$0.25V_{DDIO}$	V
Input High Voltage (V_{IH})	$0.8V_{DDIO}$		V_{DDIO}	V
Schmitt trig. Low to High threshold point (V_{T+})	1.5			V
Schmitt trig. High to Low threshold point (V_{T-})			1	V

Table 3. Digital Input Specifications

(3) Digital Output Specifications

	Min	Typ	Max	Unit
IO Supply Voltage	1.62/3	1.8/3.3	1.98/3.63	V
Output Low Voltage (V_{OL})	0		0.4	V
Output High Voltage (V_{OH})	1.3		V_{DDIO}	V
Output rise time (t_{TLH})			7	ns
Output fall time (t_{THL})			7	ns

Table 4. Digital Output Specifications

(4) I/O Digital Specification (Tri-State)

	Min	Typ	Max	Unit
IO Supply Voltage	1.62/3	1.8/3.3	1.98/3.63	
Input Low Voltage (V_{IL})	-0.3		$0.25V_{DDIO}$	V
Input High Voltage (V_{IH})	$0.8V_{DDIO}$		V_{DDIO}	V
Schmitt trig. Low to High threshold point (V_{T+})	1.5			V
Schmitt trig. High to Low threshold point (V_{T-})			1	V
Pull-Up Resistor (R_u)	0.05		1	M Ω
Pull-Down Resistor (R_d)	0.05		1	V
Output Low Voltage (V_{OL})	0		0.4	V
Output High Voltage (V_{OH})	1.3		V_{DDIO}	V
Output rise time @ 3.3V (t_{ToLH})			7	ns
Output fall time @ 3.3V (t_{ToHL})			7	ns
Input rise time (t_{TiLH})			7	ns
Input fall time (t_{TiHL})			7	ns

Table 5. I/O Digital Specification

(5) RTC Input Specifications

	Min	Typ	Max	Unit
RTC Supply Voltage (V_{DDRTC})	1.2		3.6	V
Input Low Voltage (V_{IL})	-0.3		$0.25V_{DDRTC}$	V
Input High Voltage (V_{IH})	$0.8V_{DDRTC}$		V_{DDRTC}	V
Schmitt trig. Low to High threshold point (V_{T+})	$0.57V_{DDRTC}$		$0.68V_{DDRTC}$	V
Schmitt trig. High to Low threshold point (V_{T-})	$0.27V_{DDRTC}$		$0.35V_{DDRTC}$	V

Table 6. RTC Input Specifications

(6) RTC Output Specifications

	Min	Typ	Max	Unit
RTC Supply Voltage (V_{DDRTC})	1.2		3.6	V
Output Low Voltage (V_{OL})	0		0.4	V
Output High Voltage (V_{OH})	$0.8V_{DDRTC}$		V_{DDRTC}	V
Output rise time (t_{TLH})	19		142	ns
Output fall time (t_{THL})	21		195	ns

Table 7. RTC Output Specifications

(7) Internal 1.8V regulator

	Min	Typ	Max	Unit
Output Voltage (VOUT_1V8)		1.8		V
Maximum Output Current (IVOUT_1V8)		250	300	mA
1.8V Regulator Enable "H" Voltage (EN_1V8)	1.0		VIN_3V3	V
1.8V Regulator Enable "L" Voltage (EN_1V8)	0		0.25	V

Table 8. Internal 1.8V regulator

(8) Power Consumption (VDDRTC=VDD=3.3V, VDDIO=1.8V, Temp=25°C)

WizFi 210	Min	Typ	Max	Unit
Standby mode (Only V_{DDRTC} is active)		35	50	μA
Idle mode (CPU running, WLAN disconnected)			10	mA
Receive (-81dBm RX sensitivity)		125	130	mA
Transmit (+8dBm at antenna port)		135	140	mA

Table 9. Power Consumption

(9) Power Consumption (VDDRTC=VDD=3.3V, VDDIO=3.3V, Temp=25°C)

WizFi 210	Min	Type	Max	Unit
Standby mode (Only V _{DDRTC} is active)		35	50	μA
Idle mode (CPU running, WLAN disconnected)			11	mA
Receive (-81dBm RX sensitivity)		125	130	mA
Transmit (+8dBm at antenna port)		135	140	mA

(10) RF Specification

Specification	Description
Modulation Technique	DSSS for 1, 2Mbps CCK for 5.5, 11Mbps
Data Rate	IEEE 802.11b: 1, 2, 5.5 and 11Mbps
Receive Sensitivity	-84dBm ± 1dB @ 11Mbps -88dBm ± 1dB @ 5.5Mbps -90dBm ± 1dB @ 2Mbps -94dBm ± 1dB @ 1Mbps
Transmit power (Average)	WizFi 210 : 8dBm ± 1dB @ 11Mbps WizFi 220 : TBD
Frequency Range	USA: 2.400 ~ 2.483GHz Europe: 2.400 ~ 2.483GHz Japan: 2.400 ~ 2.497GHz China: 2.400 ~ 2.483GHz
Operating Channels	USA/Canada: 11 (1~11) Major Europe Countries: 13 (1~13) France: 4 (10~13) Japan: 14 for IEEE 802.11b (1~13 or 14th), 13 for IEEE 802.11g (1~13) Korea/China: 13 (1~13)
Antenna	U.FL External Antenna Support External Antenna Pad Support 1dBi Chip Antenna (Optional)

Table 10. RF Specification

(11) Block Diagram

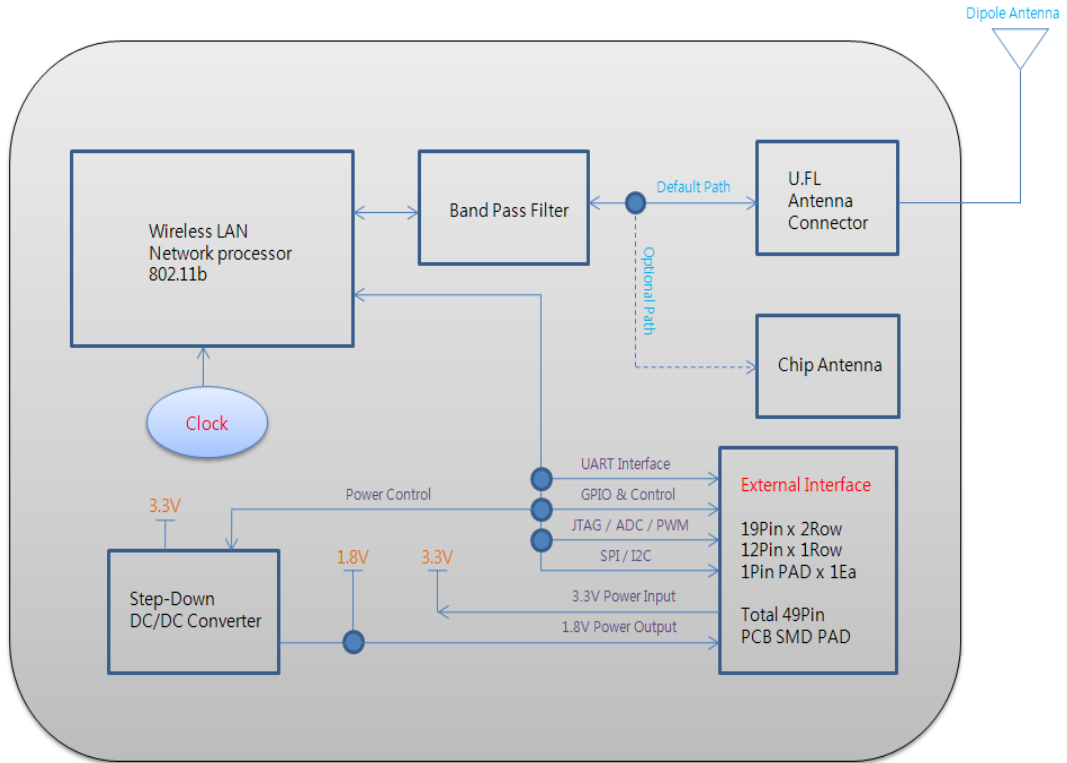

Figure 2. Block Diagram

(12) Pin Description

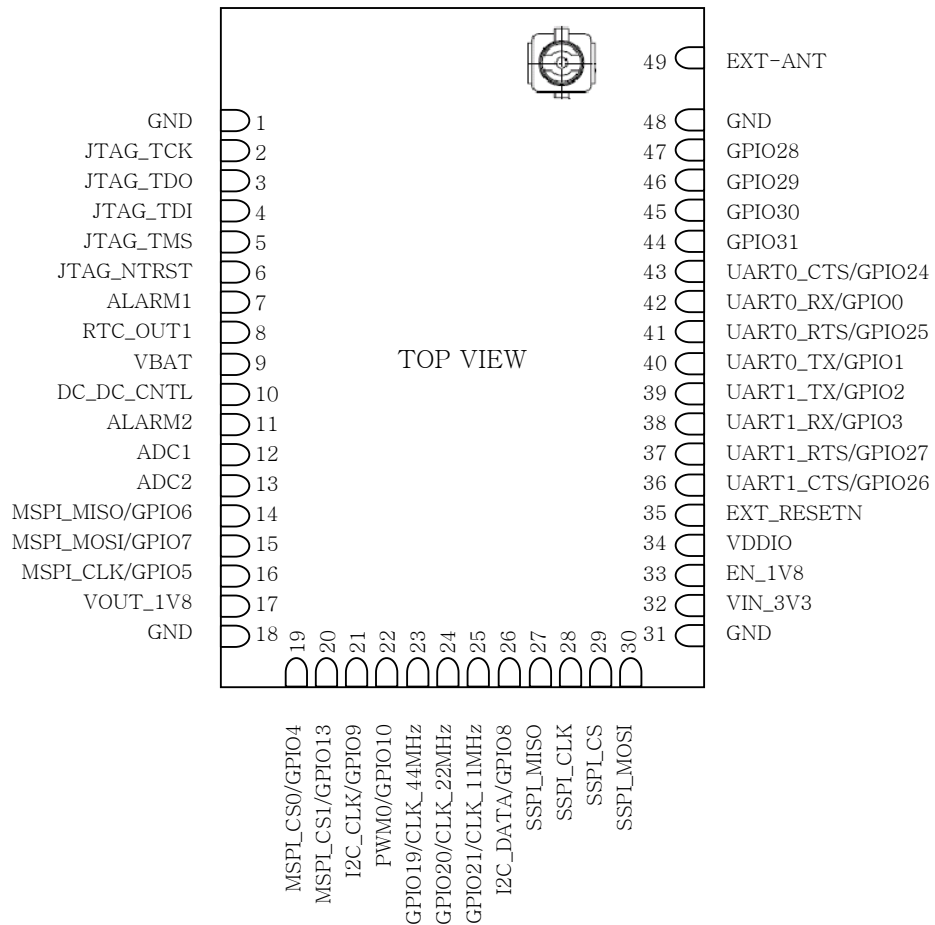

Figure 3. Pin description

PIN	NAME	I/O	IN BIAS	DESCRIPTION
1	GND	P	NA	Ground
2	JTAG_TCK (*)	I	Pull-up	Joint Test Action Group Test Clock
3	JTAG_TDO (*)	O	NA	Joint Test Action Group Test Data Out
4	JTAG_TDI (*)	I	NA	Joint Test Action Group Test Data In It should not be left floating
5	JTAG_TMS (*)	I	Pull-up	Joint Test Action Group Test Mode Select
6	JTAG_NTRST (*)	I	Pull-up	Joint Test Action Group Test Mode Reset Active Low
7	ALARM1	I	NA	Embedded Real Time Clock Wake Up Input 1
8	RTC_OUT1 (*)	O	NA	Embedded Real Time Clock Wake Up Output 1
9	VBAT	P	NA	Embedded Real Time Clock Power Supply
10	DC_DC_CNTL	O	NA	VIN_3V3 Regulator Control Output
11	ALARM2 (*)	I	NA	Embedded Real Time Clock Wake Up Input 2
12	ADC1 (*)	I	NA	General Analog to Digital Converter 1
13	ADC2 (*)	I	NA	General Analog to Digital Converter 2
14	MSPI_MISO/GPIO 6 (*)	I	Pull-down	Master Serial Peripheral Interface Bus Data Input / General Purpose Input Output
15	MSPI_MOSI/GPIO 7 (*)	O	Pull-down	Master Serial Peripheral Interface Bus Data Output / General Purpose Input Output
16	MSPI_CLK/GPIO5 (*)	O	Pull-down	Master Serial Peripheral Interface Bus Clock / General Purpose Input Output
17	VOUT_1V8 (*)	P	NA	Internal 1.8V Vout
18	GND	P	NA	Ground
19	MSPI_CS0/GPIO4 (*)	O	Pull-down	Master Serial Peripheral Interface Bus Chip Select 0 / General Purpose Input Output
20	MSPI_CS1/GPIO13 (*)	O	Pull-down	Master Serial Peripheral Interface Bus Chip Select 1 / General Purpose Input Output

21	I2C_CLK/GPIO9 (*)	IO	Pull-down	Inter-Integrated Circuit Clock / General Purpose Input Output
22	PWM0/GPIO10	O	Pull-down	Pulse Width Modulator / General Purpose Input Out-put
23	GPIO19/CLK_44M Hz (*)	I	Pull-down	Internal Clock Circuitry Test Point / General Purpose Input Output
24	GPIO20/CLK_22M Hz (*)	I	Pull-down	Internal Clock Circuitry Test Point / General Purpose Input Output
25	GPIO21/CLK_11M Hz (*)	I	Pull-down	Internal Clock Circuitry Test Point / General Purpose Input Output
26	I2C_DATA/GPIO8 (*)	IO	Pull-down	Inter-Integrated Circuit Data / General Purpose Input Output
27	SSPI_MISO (*)	O	Pull-up	SPI Slave Transmit Data Output to the HOST
28	SSPI_CLK (*)	I	Pull-up	SPI Slave Clock Input from the HOST
29	SSPI_CS (*)	I	Pull-up	SPI Slave Chip Select Input from the HOST
30	SSPI_MOSI (*)	I	Pull-down	SPI Slave Receive Data Input from the HOST
31	GND	P	NA	Ground
32	VIN_3V3	P	NA	Single Supply Port
33	EN_1V8	I	NA	Internal 1.8V regulator enable port-Active High
34	VDDIO(**)	P	NA	All I/O voltage domain (can be tied to VIN_3V3 or tied to HOST I/O supply)
35	EXT_RESETN (*)	IO	Pull-up	Module Hardware Reset Input and Power Supply Reset Monitor Indicator
36	UART1_CTS/GPIO 26 (*)	I	Pull-down	Universal Asynchronous Receiver Transmitter 1 Clear to Send Input / General Purpose Input Output
37	UART1_RTS/GPIO2 7	O	Pull-down	Universal Asynchronous Receiver Transmitter 1 Request to Send Output / General Purpose Input Out-put / Firmware Program Mode It support download mode at high during boot

38	UART1_RX/GPIO3 (*)	I	Pull-down	Universal Asynchronous Receiver Transmitter 1 Receive Input / General Purpose Input Output
39	UART1_TX/GPIO2 (*)	O	Pull-down	Universal Asynchronous Receiver Transmitter 1 Transmitter Output / General Purpose Input Output
40	UART0_TX/GPIO1	O	Pull-down	Universal Asynchronous Receiver Transmitter 0 Transmitter Output / General Purpose Input Output
41	UART0_RTS/GPIO2 5	O	Pull-down	Universal Asynchronous Receiver Transmitter 0 Request to Send Output / General Purpose Input Out-put
42	UART0_RX/GPIO0	I	Pull-down	Universal Asynchronous Receiver Transmitter 0 Receive Input / General Purpose Input Output
43	UART0_CTS/GPIO 24	I	Pull-down	Universal Asynchronous Receiver Transmitter 0 Clear to Send Input / General Purpose Input Output
44	GPIO31	IO	Pull-down	General Purpose Input Output
45	GPIO30	IO	Pull-down	General Purpose Input Output
46	GPIO29 (*)	IO	Pull-down	General Purpose Input Output
47	GPIO28	IO	Pull-down	General Purpose Input Output
48	GND	P	NA	Ground
49	EXT-ANT	IO	NA	External Antenna pad

Table 11. Pin description

(*) is not available in this version.

(**) To allow for design flexibility and support for multiple sensors with different voltages, the VDDIO banks are split, such that some of the VDDIO banks can be 1.8 V and some can be 3.3 V. If a VDDIO bank is connected to 1.8 V then the corresponding I/O signals for that bank should be driven at the same voltage.

VDDIO Bank 1 : GPIO28~29, JTAG,

VDDIO Bank 2 : SPI1(Master), Misc

VDDIO Bank 3 : GPIO18~23, PWM

VDDIO Bank 4 : I2C, SPI2(Slave), GPIO16~17

VDDIO Bank 5 : UART0~1

VDDIO Bank 6 : GPIO30~31

(13) Module Dimension

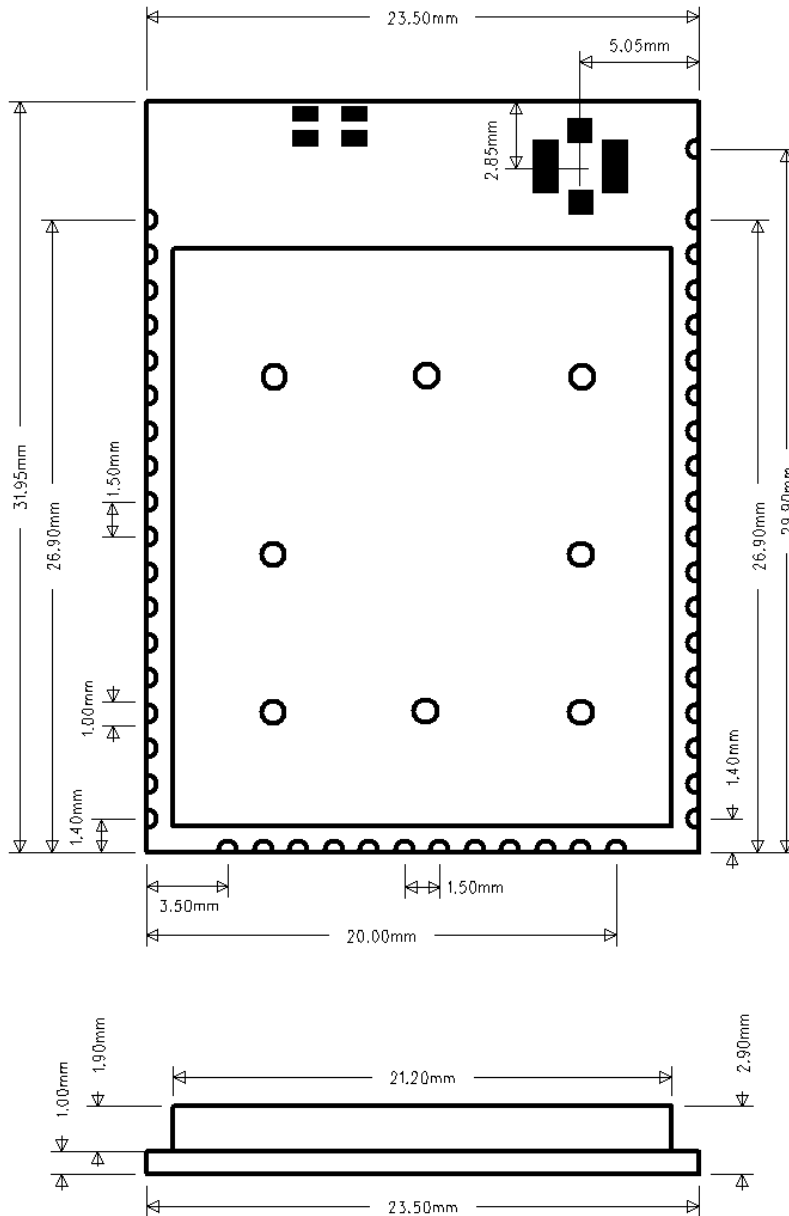

Figure 4. Module dimension

(14) Recommend Pad Dimension

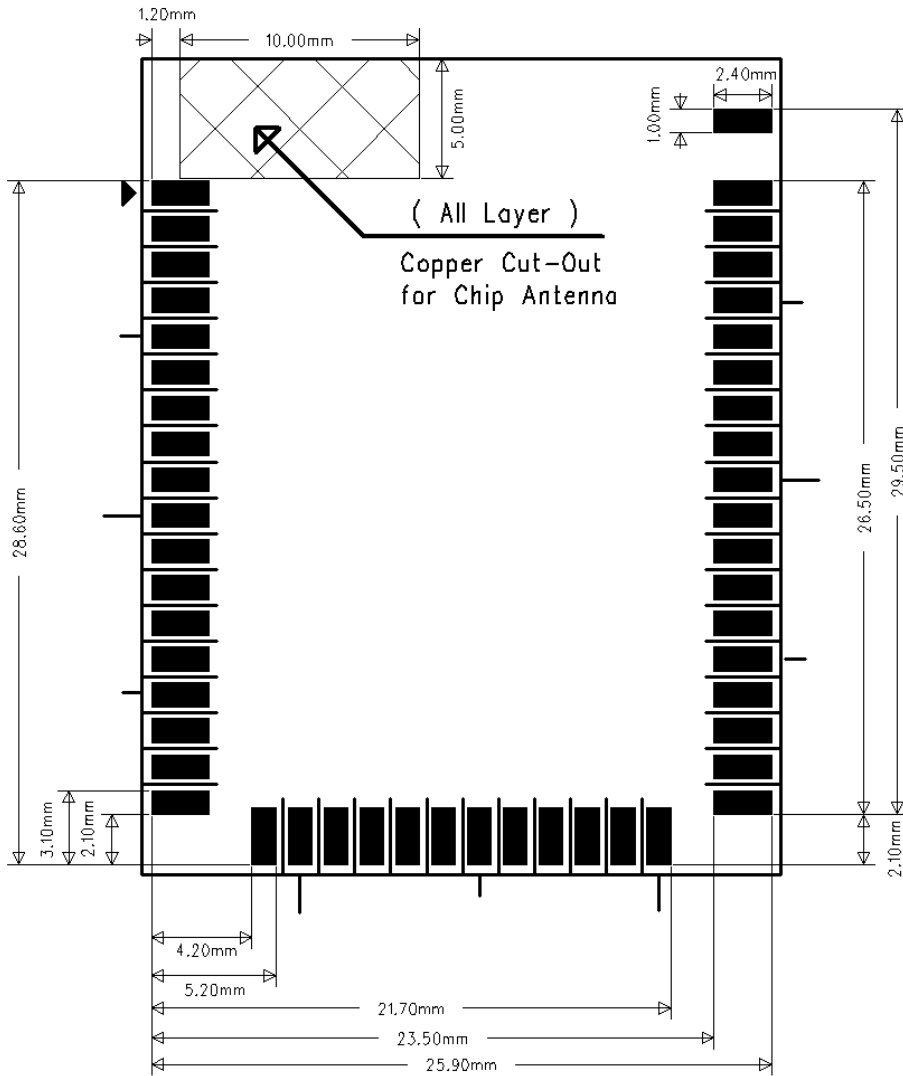

Figure 5. Recommend Pad Dimension

(15) LED Indications

Condition	D3(PWR)	D1(GPIO 30)	D2(GPIO 31)	D4 (GPIO 28)
ON Solid	Power On	-	Serial-To-WiFi OK	Associated
Blink(-1-)	-	Serial Data Rx (Data Mode)		-
Blink(-1-1-)	-	Serial Data Rx (AT Command Mode)	-	-
OFF	No Power	-	Serial-To-WiFi Error	Not Associated

Table 12. LED Indications

(16) Application Circuit

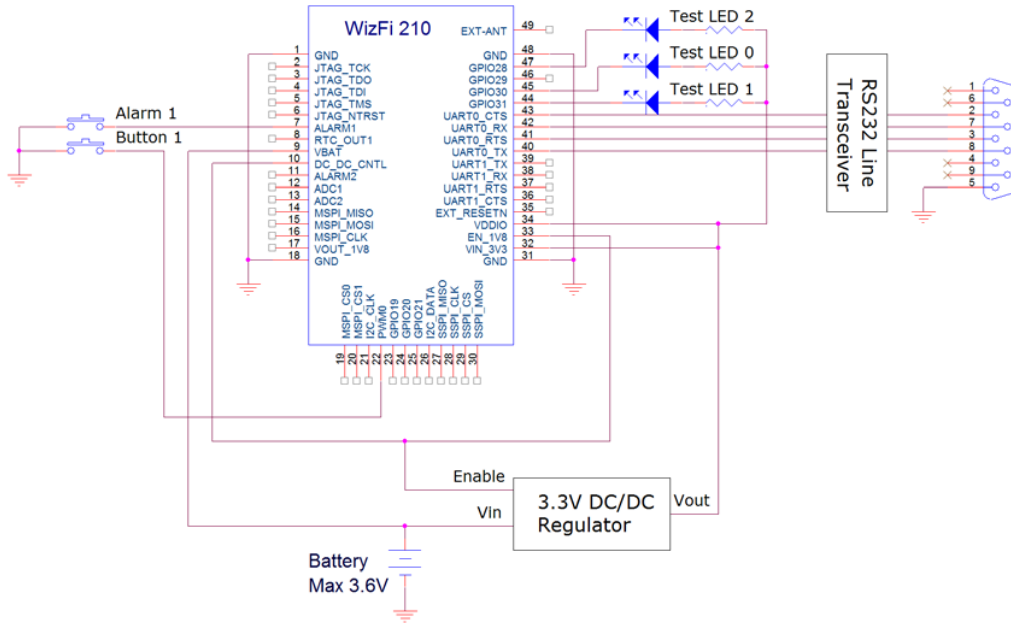

Figure 6. V_{IN} = Battery, Standby support

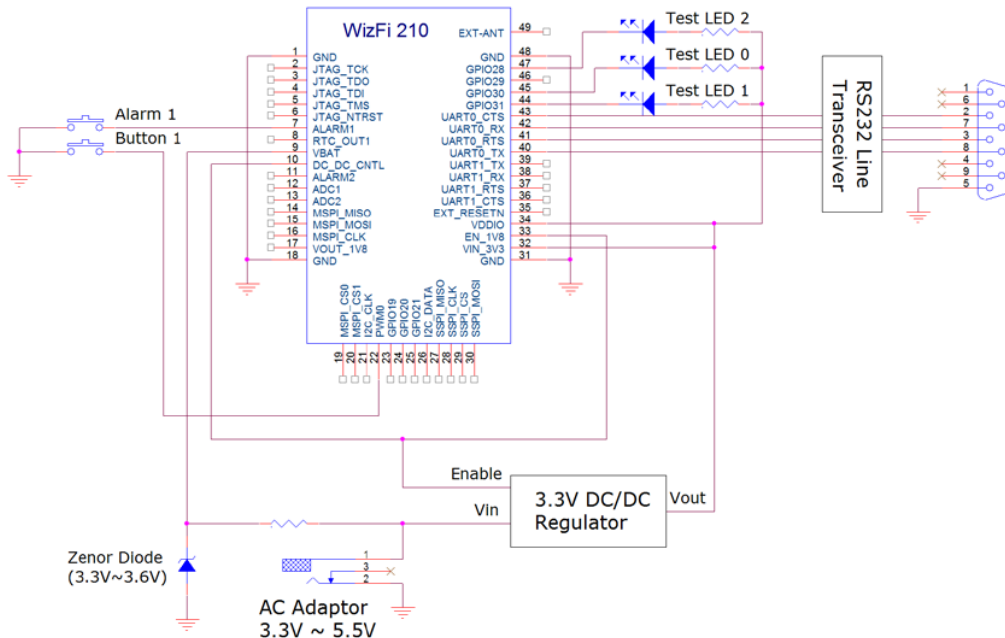

Figure 7. V_{IN} = AC Adaptor, Standby support

[Button 1](GPIO10) is used for mode transition between data/command mode, factory default and self test. So, this should be considered, except in special cases

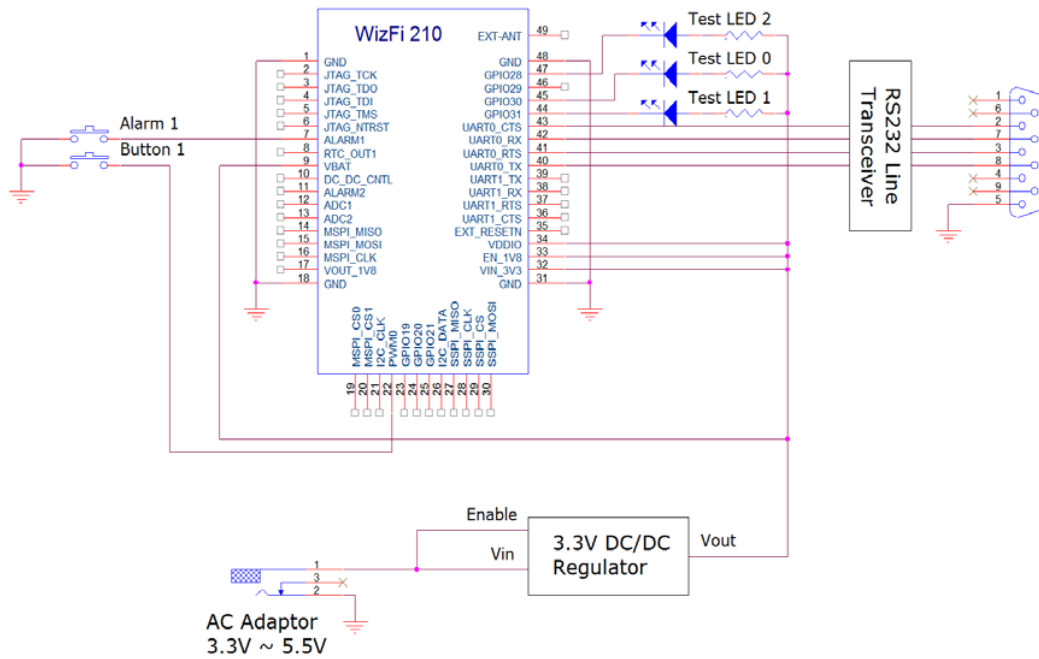

Figure 8. AC Adaptor, always ON

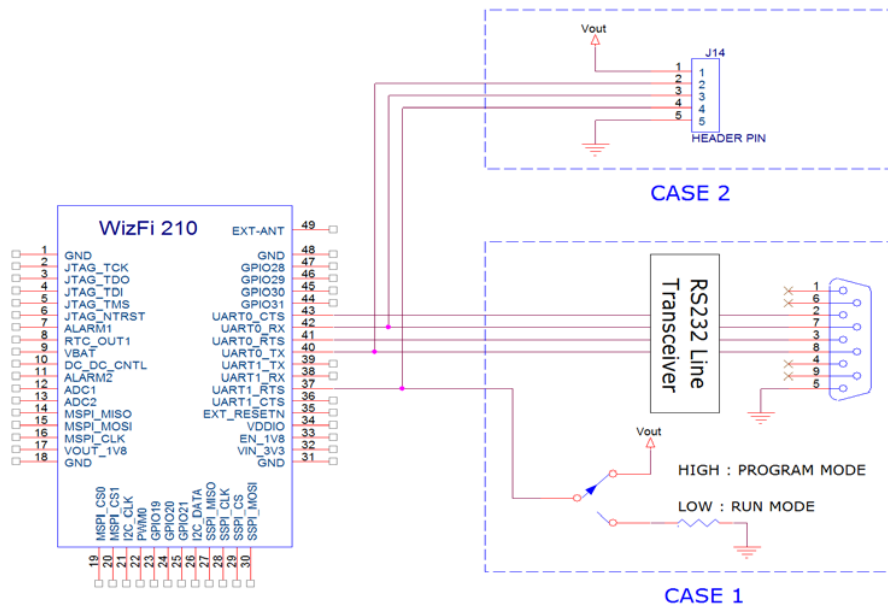

Figure 9. Firmware Download

In order to upgrade the firmware of the WizFi210, the hardware design to transit between run mode and program mode is required as shown as above.

(17) Interface

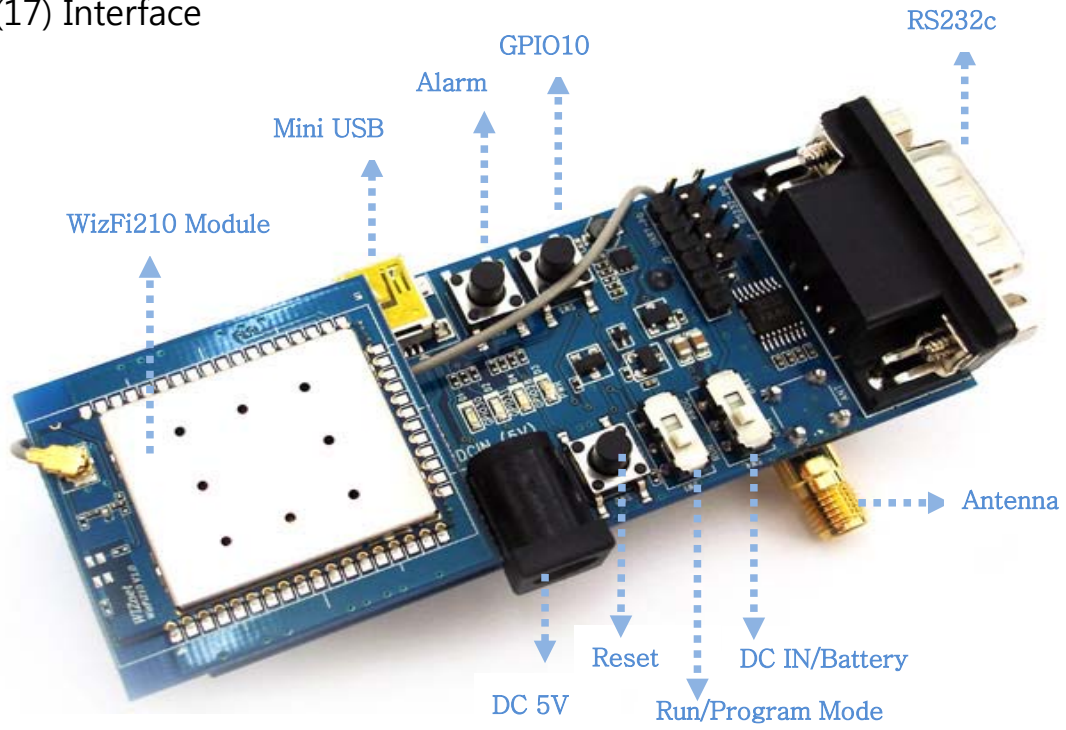

Figure 10. Interface

3. Application Guide

(1) AP Scanning

The Serial2WiFi interface can instruct the Wi-Fi radio to scan for access points and ad hoc networks with a specified SSID, BSSID and/or channel for a specified scan time. Scanning can be performed to find networks with a specific SSID, BSSID, networks operating on a specific radio channel, or a combination of these constraints.

(2) Network Connection Management

The connection management module is responsible for processing connection-related events. The interface provides UDP and TCP sockets (similar to the familiar BSD network sockets). Each socket may represent either a server or client connection. Each such connection has a unique, single-digit hexadecimal value (0 to 15) for the CID. The allowed maximum number of connections (up to 16) may be specified at compile time. Note that this single pool of CID's is used for TCP, UDP, Server and Client connections

(3) Auto Connection Operation

Auto Connection acts as a cable replacement insofar that the interface acts like a serial interface and no commands or user intervention are required for connection management. In this mode, the Station automatically builds the wireless and network connections by using parameter values from the current active Profile, then transfers data transparently between the Host and Target in data mode. No status information is sent to the Host.

The operation modes of WizFi210 are as below

Command Mode : in which data is interpreted as commands to control WizFi210

Data Mode : in which serial data is sent to the WiFi interface

In Data mode the Adapter:

- ▶ Receives characters from the serial port and transmits them over the connection
- ▶ Receives data from the connection and transmits it on the serial port

The serial host may gain control of the interface by issuing the escape sequence "+++", followed by a one-second gap where no characters are received on the serial port. When this sequence is encountered, the Adapter exits data mode and resumes command processing. The host then makes changes in the network configuration or other parameters

as needed. However, the Adapter does not accept any new TCP/UDP client/server or data connection requests.

The ATO command (terminated by the ASCII character "O", not the number 0) is used to return to data mode.

Applying the "AT+XEHT=1" command (Enable Hardware Trigger), you can change between data mode and command mode using GPIO 10, without escape sequence ("+++").

Using D2(GPIO 31), D4(GPIO 28) of WizFi210, you can see if the WizFi210 is associated to the AP and if serial-to-wifi network channel is normal.

And applying the "AT+XDUM=1" command (Disable UART Message), all UART messages are blocked in data mode. In this situation, you have to check the signal of GPIO 28 and GPIO 31 to know disassociation or network connection closed.

In data mode, the Nagle Algorithm Wait Time can be used to buffer any characters to be sent, in order to avoid sending a large number of packets with small payloads onto the network. The wait time is specified in units of 10 milliseconds. This functionality is available for both UDP and TCP connections.

(4) Response Codes

The possible responses sent by the Adapter to the serial host are described below.

The Response Codes can be distinguished into codes resulting from the AT Command or not. There are Carriage Return(␣, 0x0d) and Line Feed(␣, 0x0a) above and below ASCII STRING. If you send "at" string and Line Feed to the WizFi210,
at + Line Feed (0x61 0x74 0x0d)

You can see the following data.

at + Carriage Return (0x61 0x74 0x0d) + ␣␣[OK]␣␣ (0x0d 0x0a 0x5b 0x4f 0x4b 0x5d 0x0d 0x0a)

No	ASCII CHAR	Response	ASCII STRING	Meaning
1	0	S2W_SUCCESS	[OK]	Command Request Success.
2	1	S2W_FAILURE	[ERROR]	Command Request Failed.
3	2	S2W_EINVAL	[ERROR: INVALID INPUT]	Invalid Command or Option or Parameter.
4	3	S2W_SOCKET_FAIL	[ERROR: SOCKET FAILURE]	Socket Operation Failed.
5	4	S2W_ENOCID	[ERROR: NO CID]	All allowed CID's in use, so there was no CID to assign to the new

				connection.
6	5	S2W_EBADCID	[ERROR: INVALID CID]	Invalid Connection Identifier.
7	6	S2W_ENOTSUP	[ERROR: NOT SUPPORTED]	Operation or Feature not supported.
8	7	S2W_CON_SUCCESS	[CONNECT <CID> <info>]	TCP/IP connection successful. <CID> = the new CID in hexadecimal format.
9	8	S2W_ECIDCLOSE	[DISCONNECT <CID>]	TCP/IP connection with the given CID is closed. This response is sent to the host when a connection is closed either by the remote device or by the serial host.
10	9	S2W_LINK_LOST	[DISASSOCIATED]	Not associated to a wireless network.
11	A	S2W_DISASSO_EVT	[Disassociation Event]	Wireless network association lost.

Table 13. Response Codes

(5) Use of GPIO10

If you click the GPIO10 button twice consecutively, the WizFi210 is restored to factory default. And if you click the GPIO10 button three times consecutively, the WizFi210 is restored to factory default and will change to ad hoc mode to configure the WizFi210 via WiFi. (IP:192.168.1.254/Subnet:255.255.255.0/Gateway:192.168.1.1)

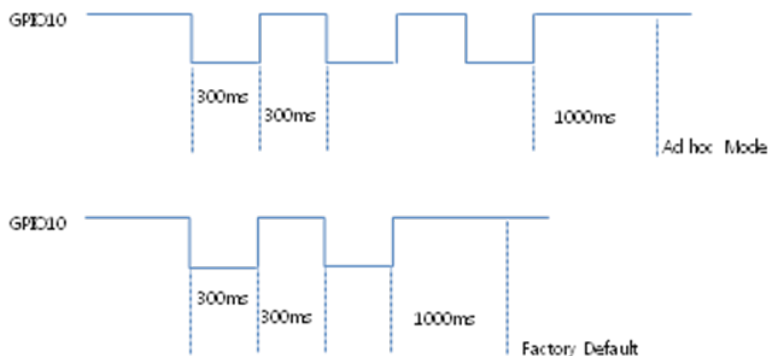

Figure 11. Factory Default and ad hoc mode

As previously described, GPIO10 is used for data/command mode transition by applying "AT+XEHT=1" command. But there should be no UART input in 300mS before and after sending signal to GPIO10 for mode transition time and buffer processing time.

(6) AT Command example

AT Command examples are described below. In this sample application, the WizFi210 associate to the AP and open the serial-to-wifi channel automatically after reboot. Description of each command is in the next chapter.

No	MCU → WizFi210 (AT Command)	WizFi210 → MCU (Echo and Result String)	Description
1	AT+WD	AT+WD [OK]	Disassociate
2	AT+WWPA=12345678	AT+WWPA=12345678 [OK]	Set WPA passphrase
3	AT+NDHCP=1	AT+NDHCP=1 [OK]	Enable DHCP
4	AT+WAUTO=0,WizFiAP,,0	AT+WAUTO=0,WizFiAP,,0 [OK]	Set WiFi Configuration
5	AT+NAUTO=1,1,,4000	AT+NAUTO=1,1,,4000 [OK]	TCP Server Mode(4000)
6	ATC1	ATC1 [OK]	Auto Connect on next reboot
7	AT+XEHT=0	AT+XEHT=0 [OK]	Disable Hardware Trigger
8	AT+XDUM=1	AT+XDUM=1 [OK]	Disable UART Message
9	AT&Y0	AT&Y0 [OK]	Set Default Profile
10	AT&W0	AT&W0 [OK]	Save Profile

Table 14. AT Command Example

4. AT Commands

This section provides a list of Serial2WiFi commands and their effects. Parameters are generally ASCII characters, e.g. ATEn with n=1 is the series of ASCII characters 'A', 'T', 'E', and '1'. Where some parameters are optional, mandatory parameters are denoted by < > and optional parameters by []. If a parameter is mandatory, any associated sub-parameters are also mandatory; sub-parameters of an optional parameter are optional. Parameters must always be provided in the order given in the command description. When an optional parameter is not supplied, the comma delimiters must still be included in the command. Every command starts with the characters "AT"; any other initial characters will cause an error to be returned.

Command Response: In most cases, valid commands return the characters OK. Invalid inputs return ERROR: INVALID INPUT.

Some commands may be not supported depending on the version

(1) Command interface

Command	Parameters	Responses / Effects
AT		"OK"
ATE	n=0 (disable) =1 (enable)	IF 1, echo all input. Ex) ATE0, ATE1
ATV	n=0 (disable) =1 (enable)	IF 1 responses are ASCII, else numerical codes. Ex) ATV0, ATV1

Table 15. Command interface

(2) UART / adapter interface configuration

Command	Parameters	Responses / Effects
ATB	<baudrate> [[,<bitsperchar>] [,<parity>],[,<stopbits>]]	UART parameters are immediately reset to values provided.(9600, 19200, 38400, 57600, 115200, 230400) Parity is n for no parity, e for even parity and o for odd parity. Allowed values are 5, 6, 7 or 8 bits/character, with 1 or 2 stop bits (1.5 in the case of a 5-bit character). Ex) ATB=9600,8,n,1

AT&K	n=0 (disable) =1 (enable)	IF 1, software flow control is enabled. Ex) AT&K0, AT&K1
AT&R	n=0 (disable) =1 (enable)	IF 1, hardware flow control is enabled. Ex) AT&R0, AT&R1
ATS	n=0 to 5; p=(parameter value)	Sets various timeout values; 0 (Network Connection Timeout, 10 milliseconds, 1~65535, default 1000) 1 (Auto Associate Timeout 10 milliseconds, 0~65535, default 500) 2 (TCP Connection Timeout 10 milliseconds, 0~65535, default 500) 3 (Association Retry Count Not currently supported) 4 (Nagle Algorithm Wait Time 10 milliseconds, 0~65535, default 10) 5 (Scan Time 1 milliseconds, 0~65535, default 20) Ex) ATS0=1000, ATS1=500
ATI	n=0 to 2;	Various Adapter ID information; 0 (OEM identification) 1 (Hardware version) 2 (Software version) Ex) ATI0, ATI2

Table 16. Uart / adapter interface configuration

(3) Profile management

Command	Parameters	Responses / Effects
AT&W	n=0 (profile 0) =1 (profile 1)	Save profile specified by n. Ex) AT&W0
ATZ	n=0 (profile 0) =1 (profile 1)	Load profile specified by n. Ex) ATZ0
AT&Y	n=0 (profile 0) =1 (profile 1)	Set default profile to the value n. AT&Y0
AT&F		Restore profile to factory default values.
AT&V		Current and saved profile parameter values as ASCII.

Table 17. Profile management

(4) Wi-Fi interface

Command	Parameters	Responses / Effects
AT+NMAC=?		Returns the current adapter MAC address.
AT+NMAC2=?		Returns the current adapter MAC address.
AT+WREGDOMAIN= MAIN=	<Regulatory Domain>	0: FCC : supported Channel range is 1 to 11. 1: ETSI : supported Channel range is 1 to 13. 2: TELEC : supported Channel range is 1 to 14. Ex) AT+WREGDOMAIN=? AT+WREGDOMAIN=2
AT+WS=	[<SSID>[,<BSSID>][,<Channel>][,<Scan Time>]]	Network scan, returns list of found networks in the format: <SSID>,<BSSID>,<Channel>,<RSSI>,<Mode>,<Security> Ex) AT+WS AT+WS=,,6
AT+WM=	n=0 (infrastructure) =1 (ad hoc)	Set 802.11 Station operating mode. Ex) AT+WM=0
AT+WA=	<SSID>[,<BSSID>][,<Ch>]]	Associate to specified SSID, BSSID, and channel. Ex)AT+WA=WizFiDemoAP
AT+WD		Disassociate from the current network.
ATH		Disassociate from the current network.
AT+WWPS=	<METHOD>[,<PIN>]	Associate to an AP using WPS METHOD is push button (1) or pin (2). PIN is the pin for PIN method. AT+WWPS=2,12345670
AT+NSTAT=?		Current wireless and network configuration.
AT+WSTATUS		Adapter reports the current network configuration to the serial host
AT+WRSSI=?		Current RSSI as ASCII.
AT+WRATE=?		Current transmit rate as ASCII.
AT+WRETRY=	<retrycount>	Value of 802.11 TX retry is reset. Ex) AT+WRETRY=5

Table 18. Wi-Fi interface

(5) Wi-Fi security

Command	Parameters	Responses / Effects
---------	------------	---------------------

AT+WAUTH=	n=0 to 2	Authentication mode setting; 0 : None 1 : Open 2 : Shared with WEP Ex) AT+WAUTH=0
AT+WWEpn=	n=1 to 4, <key>	WEP key n is set to the value in <key>. Ex) AT+WWEp1=123456abdc AT+WWEp3=abcdef12345678901234567890
AT+WWPA=	<passphrase>	WPA passphrase set to the value in <passphrase>. Ex) AT+WWPA=12345678
AT+WPAPSK=	<SSID>,<passphrase>	Computes and stores the WPA2 PSK value. Ex) AT+WPAPSK=WizFiDemoAP,12345678
AT+WPSK=	<PSK>	Sets the WPA2 pre-shared key to the <PSK>. Ex)AT+WPSK=0001020304050607080900010203040506070809000102030405060708090001
AT+WEAPCONF=	<Outer Authentication>,<Inner Authentication>,<user name>,<password>	Set the Outer authentication, Inner authentication, user name and password for EAP Security. This command returns the normal response codes. The valid outer authentication values are: Eap-FAST: 43 Eap-TLS: 13 Eap-TTLS: 21 Eap-PEAP: 25 The valid Inner Authentication values are: Eap-MSCHAP: 26 Eap-GTC: 6 Ex) AT+WEAPCONF=43,26,guest,1234
AT+WEAP=	<Type>,<Format>,<Size>,<Location> <ESC>W <data of size above>	Configure certificate for EAP-TLS Type: CA certificate(0)/ Client certificate(1)/ Private Key(2) Format: Binary(0)/Hex(1) Size: size of the file to be transferred. Location: Flash(0)/Ram(1) Ex) AT+WEAP=2,0,100,0 (cont.) <Esc>W<..data..>

Table 19. Wi-Fi security

(6) Wireless configuration

Command	Parameters	Responses / Effects
AT+WRXACTIVE=	n=0 (disable) =1 (enable)	If 1, 802.11 radio is enabled. Ex) AT+WRXACTIVE=1
AT+WRXPS=	n=0 (disable) =1 (enable)	If 1, Power Save mode is enabled. Ex) AT+WRXPS=1
AT+MCSTSET=	n=0 (disable) =1 (enable)	If 1, multicast reception is enabled.
AT+WP=	<power> 0 to 7 (WizFi210) 2 to 15 (WizFi220)	Transmit power set to <power>. Ex) AT+WP=0
AT+WSYNCINTRL=	<n> 1 to 65535.	Configure the sync loss interval Ex) AT+WSYNCINTRL=30
AT+EXTPA=	n=0 (disable) =1 (enable)	Enable/disable the external PA Ex) AT+EXTPA=0
AT+PSPOLLINTRL=	<n> 1 to 65535.	Configure the keep-alive timer interval Ex) AT+PSPOLLINTRL=45

Table 20. Wireless configuration

(7) Network interface

Command	Parameters	Responses / Effects
AT+NDHCP=	n=0 (disable) =1 (enable)	If 1, DHCP is enabled.
AT+NSET=	<Src Address>, <Net-mask>, <Gateway>	Static network parameters; overrides previous values. Ex) AT+NSET=192.168.3.100,255.255.255.0,192.168.3.1
AT+DNSLOOKUP=	<URL>,[<retry>],[<timeout=S>]	Query DNS server for address of hostname URL. Ex) AT+DNSLOOKUP=google.com
AT+DNSSET=	<DNS1 IP>,[<DNS2 IP>]	Set the DNS server addresses to be used. Ex) AT+DNSSET=192.168.3.1
AT+STORENWCONN		Store network connection parameters prior to transition to Standby.
AT+RESTORENWCONN		Restore network connection parameters after wake from Standby.

Table 21. Network interface

(8) Connection management

Command	Parameters	Responses / Effects
AT+NCTCP=	<Dest-Address>,<Port>	Attempt TCP client connection to Destination; CONNECT <CID> if successful. Ex) AT+NCTCP=192.168.3.200,5000
AT+NCUDP=	<Dest-Address>,<Port> [,<Src.Port>]	Open UDP client socket to Destination; CONNECT <CID> if successful. Ex) AT+NCUDP=192.168.3.200,5000
AT+NSTCP=	<Port>	Start a TCP server on Port; CONNECT <CID> if successful. Ex) AT+NSTCP=5000
AT+NSUDP=	<Port>	UDP server on Port; CONNECT <CID> if successful. Ex) AT+NSUDP=5000
AT+CID=?		Returns the current CID configuration.
AT+NCLOSE=	<CID>	Close connection identified by CID. Ex) AT+NCLOSE=1
AT+NCLOSEAL L		Close all open connections.
AT+SETSOCKO PT=	<Cid>,<Type>,<Parameter>,<Value>,<Length>	Configure a socket which is identified by a Cid
AT+SSLOPEN=	<cid>,<certificate name>	Open an SSL connection
AT+SSLCLOSE =	<cid>	Close an SSL connection
AT+HTTPCCO NF=	<Param>,<Value>	Configure an HTTP client
AT+HTTPCOPE N=	<host>,<Port Number>,[<SSL Flag>,<certificate name>]	Open an HTTP client connection. This command opens an HTTP client on the adaptor and connects to the server specified by the host name or IP address
AT+HTTPCSEN D=	<cid>,<Type>,<Timeout>,<Page>,[<Size of content>]	GET/POST HTTP data on the HTTP client connection
AT+HTTPCCLO SE=	<cid>	Close the HTTP client connection
AT+NRAW=	<0 1 2>	Enable / Disable Raw Ethernet support.
AT+UNSOlicit EDTX=	<Frame Control>,<Sequence Cntrl>,<Channel>,<Rate>,<WmmI nfo>,<Receiver Mac>,<Bssid of	Unsolicited data transmission

	AP>,<Frame Length>	
--	--------------------	--

Table 22. Connection management

(9) Battery check

Command	Parameters	Responses / Effects
AT+BCHKSTRT =	<Batt.chk.freq>	Start checking battery each $0 < \text{Batt.chk.freq} \leq 100$ packets transmitted.
AT+ BATTVLSET=	<Warning Level>,<Warning Freq>,<Standby Level>	Set the battery warning/standby level to enable the adaptor's internal battery measuring logic
AT+BCHK=	<Batt.chk.freq>	Reset value of battery check frequency.
AT+BCHKSTOP		Stop checking battery.
AT+BATTVALG ET		Retrieve the most recent battery check value.

Table 23. Battery check

(10) Power state management

Command	Parameters	Responses / Effects
AT+PSDPSLEE P		Enable SOC Deep Sleep power saving mode.
AT+PSSTBY=	<x>[,<DelayTime>,<Alarm1 pol.>,<Alarm2 pol.>]	Request transition to Standby for x milliseconds. Ex) AT+PSSTBY=60000,1000,1,1 AT+PSSTBY=5000

Table 24. Power state management

(11) Auto connection

Command	Parameters	Responses / Effects
AT+WAUTO=	<mode>,<SSID>,<BSSID>,[channel]	Sets WiFi parameters to be used for Auto Connect. Mode is 0 for Infrastructure and 1 for Ad-hoc mode Ex) AT+WAUTO=0,WizFiDemoAP
AT+NAUTO=	<Type>,<Protocol>,<Destination IP>,<Destination Port>	Sets network parameters to be used for Auto Connect. Type is 0 for Client and 1 for Server; Protocol is 0 for UDP and 1 for TCP;

		Ex) AT+NAUTO=0,1,192.168.3.101,5000 (TCP/Client) AT+NAUTO=1,1, ,5001 (TCP/Server) AT+NAUTO=0,0,192.168.3.101,5002 (UDP, Local/Remote Port is 5002)
ATC	n=0 (disable) =1 (enable)	IF 1, Auto Connect is enabled on next reboot or AT.
ATA		Start Auto Connect, including association.
ATA2		Start Auto Connect using existing association.
ATO		Return to a previous Auto Connect session; returns an error if no such session exists.
AT+XAR=	n=0 (disable) 5 to 3600 (interval, seconds)	Auto reconnect interval. Ex) AT+XAR=0, AT+XAR=10

Table 25. Auto connection

(12) Provisioning

Command	Parameters	Responses / Effects
AT+WEBPROV=	<user name>,<passwd>	Provisioning through web pages
AT+WEBLOGO ADD=	<size> maximum size is 1788 bytes	Adding the Logo that will appear on the web pages used for provisioning.

Table 26. Provisioning

(13) Miscellaneous

Command	Parameters	Responses / Effects
AT+FWUP=	<SrvIp>,<SrvPort>,<SrcPort>,<retry>]	Get a firmware upgrade from the server address/port to the adapter port SrcPort. Ex) AT+FWUP=192.168.3.200,667,667
AT+SETTIME=	<dd/mm/yyyy>,<HH:MM:SS>	Set the adaptor system time
AT+GETTIME=?		Upon reception of this command the adaptor sends the current system time in milliseconds since epoch(1970) to the serial interface. The time format comes on the serial interface as follows: "Current Time in msec since epoch=xxxxxxx"
AT+DGPIO=	<GPIO-NO>,<SET/RESET(0/1)>	Set or reset (high/low) a GPIO pin Ex) AT+DGPIO=31,0

AT+VER=?		Return the current adapter firmware versions.
AT+PING=	<IP>,[Trails],[<Interval>],[<Len>],[<TOS>],[<TTL>],[<PAYLOAD>]]	PING the IP address provided. Trails = 0 will ping until <Esc> C is issued. Ex) AT+PING=192.168.3.1,5
AT+TRACEROUTE=	<IP>,[Interval],[<MaxHops>],[<MinHops>],[<TOS>]]	Trace the route to the IP address provided. Ex) AT+TRACEROUTE=74.125.155.103
AT+XDUM=	n=1 (disable) =0 (enable)	If 1, UART Message is Disabled.(When Auto Connection Mode)
AT+XEHT=	n=0 (disable) =1 (enable)	If 1, Hardware Trigger is Enabled.

Table 27. Miscellaneous

5. Warranty

WIZnet Co., Ltd offers the following limited warranties applicable only to the original purchaser. This offer is non-transferable.

WIZnet warrants our products and its parts against defects in materials and workmanship under normal use for period of standard ONE(1) YEAR for the WizFi210 board and labor warranty after the date of original retail purchase. During this period, WIZnet will repair or replace a defective products or part free of charge.

Warranty Conditions:

1. The warranty applies only to products distributed by WIZnet or our official distributors.
2. The warranty applies only to defects in material or workmanship as mentioned above in 3.Warranty. The warranty applies only to defects which occur during normal use and does not extend to damage to products or parts which results from alternation, repair, modification, faulty installation or service by anyone other than someone authorized by WIZnet Co., Ltd. ; damage to products or parts caused by accident, abuse, or misuse, poor maintenance, mishandling, misapplication, or used in violation of instructions furnished by us ; damage occurring in shipment or any damage caused by an act of God, such as lightening or line surge.

Procedure for Obtaining Warranty Service

1. Contact an authorized distributors or dealer of WIZnet Co., Ltd. for obtaining an RMA (Return Merchandise Authorization) request form within the applicable warranty period.
2. Send the products to the distributors or dealers together with the completed RMA request form. All products returned for warranty must be carefully repackaged in the original packing materials.
3. Any service issue, please contact to sales@wiznet.co.kr