

PIN 1
INDEX AREA

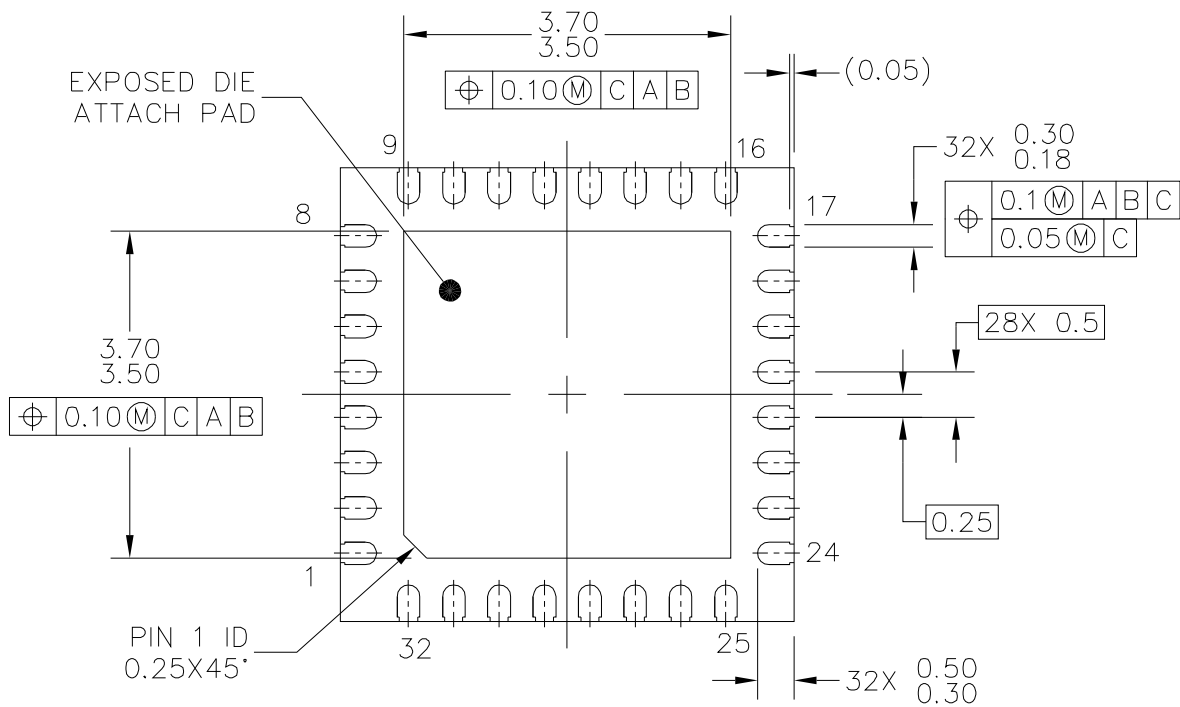
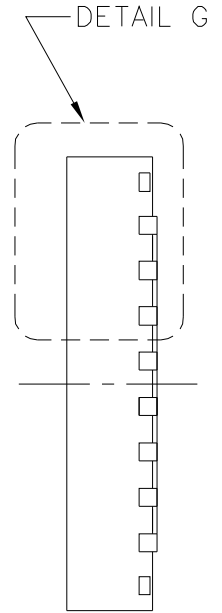
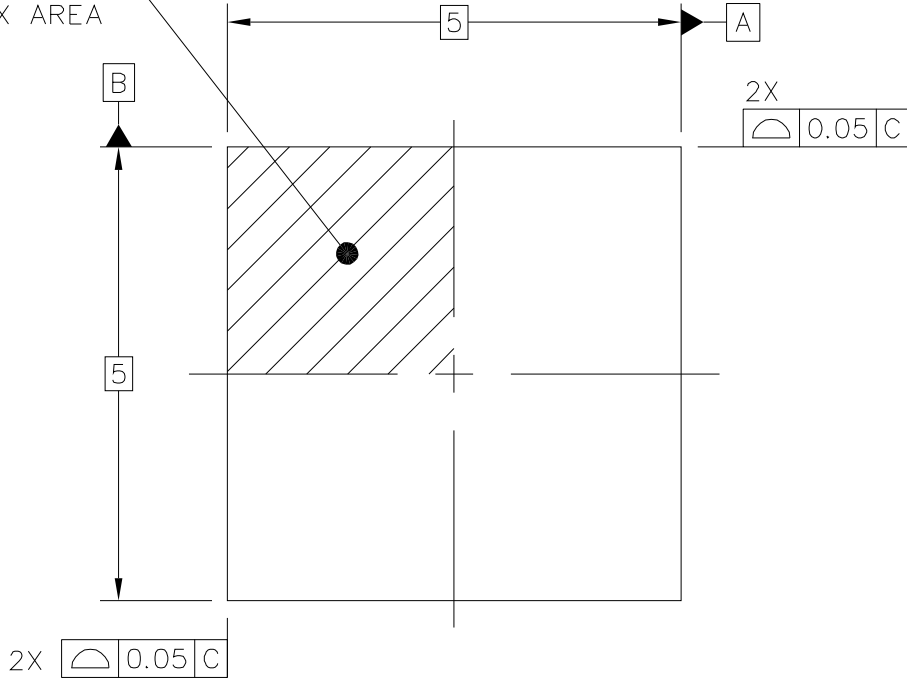

© FREESCALE SEMICONDUCTOR, INC.
ALL RIGHTS RESERVED.

MECHANICAL OUTLINE

PRINT VERSION NOT TO SCALE

TITLE:
QFN, THERMALLY ENHANCED
5 X 5 X 0.9, 0.5 PITCH, 32 TERMINAL

DOCUMENT NO: 98ASA00473D

REV: A

CASE NUMBER: 2295-02

11 OCT 2012

STANDARD: NON-JEDEC

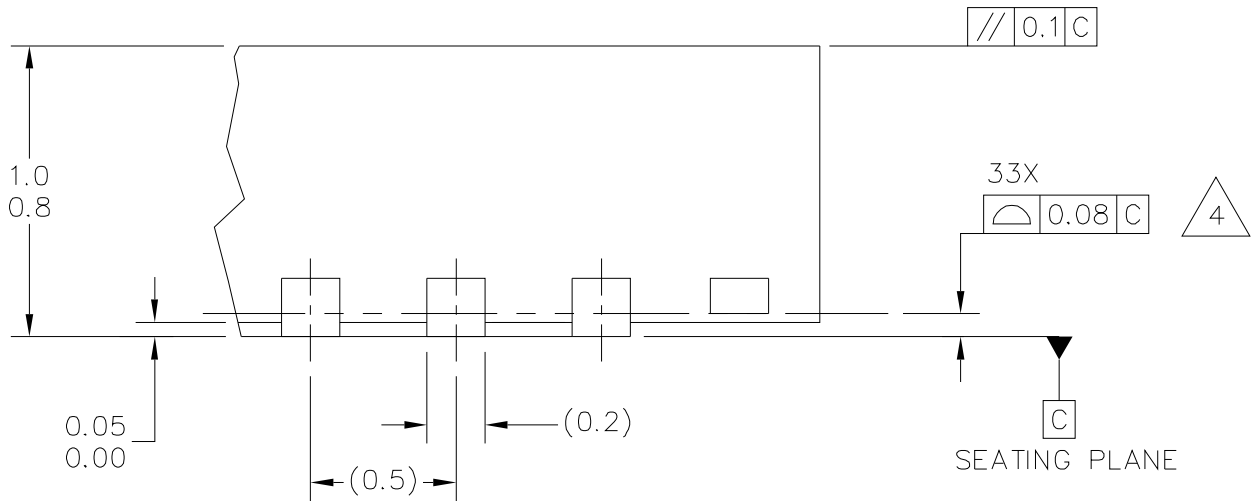

DETAIL G
VIEW ROTATED 90°CW

© FREESCALE SEMICONDUCTOR, INC. ALL RIGHTS RESERVED.	MECHANICAL OUTLINE	PRINT VERSION NOT TO SCALE	
TITLE: QFN, THERMALLY ENHANCED 5 X 5 X 0.9, 0.5 PITCH, 32 TERMINAL	DOCUMENT NO: 98ASA00473D	REV: A	
	CASE NUMBER: 2295-02	11 OCT 2012	
	STANDARD: NON-JEDEC		

NOTES:

1. ALL DIMENSIONS ARE IN MILLIMETERS.
2. DIMENSIONING AND TOLERANCING PER ASME Y14.5M-1994.
3. THIS IS A NON-JEDEC REGISTERED PACKAGE.
4.  COPLANARITY APPLIES TO LEADS AND DIE ATTACH FLAG.
5. MIN. METAL GAP SHOULD BE 0.2 MM.

© FREESCALE SEMICONDUCTOR, INC. ALL RIGHTS RESERVED.	MECHANICAL OUTLINE	PRINT VERSION NOT TO SCALE	
TITLE: QFN, THERMALLY ENHANCED 5 X 5 X 0.9, 0.5 PITCH, 32 TERMINAL	DOCUMENT NO: 98ASA00473D	REV: A	
	CASE NUMBER: 2295-02	11 OCT 2012	
	STANDARD: NON-JEDEC		