

10Gbps 1:16 Deserializer with Clock Recovery

General Description

The MAX3953 is a 9.953Gbps/10.3125Gbps 1:16 deserializer with clock recovery for 10Gbps Ethernet and OC192 SONET applications. The integrated phase-locked loop (PLL) recovers a clock from the serial data input, and the data is then retimed and demultiplexed into 16 parallel LVDS outputs. Using Maxim's SiGe bipolar process, the MAX3953 can achieve 0.75UI of high-frequency jitter tolerance comprised of 0.50UI of deterministic jitter and 0.25UI of random jitter.

The MAX3953 includes TTL-compatible loss-of-lock (LOL) and sync-error (SYNC_ERR) indicators that allow the user to verify that the part has locked on to incoming data. In case the incoming data becomes invalid, a clock holdover function is provided to maintain a valid reference clock to the upstream device. For proper operation, a reference clock of baud rate/64 or baud rate/16 is required.

The MAX3953 operates from a single +3.3V power supply and typically dissipates 1.5W. The operating temperature range is from 0°C to +85°C. The MAX3953 is available in a 68-pin QFN package.

Applications

10Gbps Ethernet LAN
10Gbps Ethernet WAN
Add/Drop Multiplexers
Digital Cross-Connects

Features

- ◆ **Serial Data Rate: 9.953Gbps/10.3125Gbps**
- ◆ **Clock Recovery with 1:16 Demultiplexer**
- ◆ **0.75UI_{p-p} High-Frequency Jitter Tolerance**
- ◆ **16-Bit Parallel LVDS Output**
- ◆ **OIF-Compliant Parallel Interface**
- ◆ **Loss-of-Lock (LOL) Indicator**
- ◆ **Differential Input Range: 100mV_{p-p} to 1.2V_{p-p}**
- ◆ **Clock Holdover**
- ◆ **Reference Clock: Baud Rate/64 or Baud Rate/16**
- ◆ **Temperature Range: 0°C to +85°C**
- ◆ **10mm × 10mm 68-Pin QFN Package**

MAX3953

Ordering Information

PART	TEMP RANGE	PIN-PACKAGE
MAX3953UGK	0°C to +85°C	68 QFN (10mm × 10mm)

Pin Configuration and Functional Diagram appear at end of data sheet.

Typical Operating Circuit

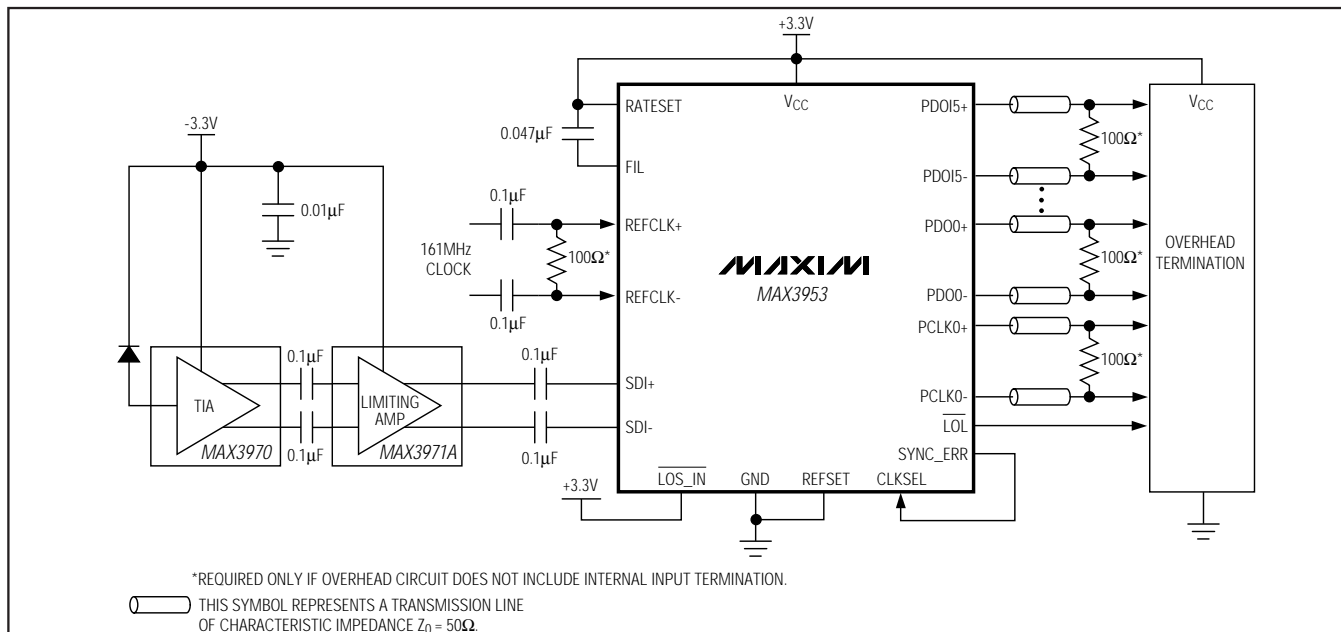

10Gbps 1:16 Deserializer with Clock Recovery

ABSOLUTE MAXIMUM RATINGS

Supply Voltage (V_{CC})-0.5V to +5.0V
 Input Voltage Levels
 (SDI+, SDI-)($V_{CC} - 1.0V$) to ($V_{CC} + 0.5V$)
 LVDS Output Voltage Levels
 (PDO[15..0] \pm , PCLKO+, PCLKO-)-0.5V to ($V_{CC} + 0.5V$)
 Voltage at LOL, SYNC_ERR, RATESET, CLKSEL, REFCLK+,
 REFCLK-, REFSET, LOS_IN, FIL-0.5V to ($V_{CC} + 0.5V$)

Continuous Power Dissipation ($T_A = 85^\circ\text{C}$)
 68-Lead QFN (derate 30.3mW/ $^\circ\text{C}$ above +85 $^\circ\text{C}$)2.5W
 Operating Temperature Range..... 0 $^\circ\text{C}$ to +85 $^\circ\text{C}$
 Storage Temperature Range-55 $^\circ\text{C}$ to +150 $^\circ\text{C}$
 Lead Temperature (soldering, 10s)+300 $^\circ\text{C}$
 Processing Temperature (die)+400 $^\circ\text{C}$

Stresses beyond those listed under "Absolute Maximum Ratings" may cause permanent damage to the device. These are stress ratings only, and functional operation of the device at these or any other conditions beyond those indicated in the operational sections of the specifications is not implied. Exposure to absolute maximum rating conditions for extended periods may affect device reliability.

DC ELECTRICAL CHARACTERISTICS

($V_{CC} = +3.0V$ to +3.6V, $T_A = 0^\circ\text{C}$ to +85 $^\circ\text{C}$. Typical values are at +3.3V and $T_A = +25^\circ\text{C}$, unless otherwise noted.)

PARAMETER	SYMBOL	CONDITIONS	MIN	TYP	MAX	UNITS
POWER SUPPLY						
Supply Current	I_{CC}			476	580	mA
INPUT SPECIFICATION (SDI+, SDI-) Figure 1						
Differential Input Voltage	V_{ID}	AC-coupled or DC-coupled input	100		1200	mVp-p
Common-Mode Input Range		DC-coupled	$V_{CC} - 0.3$		V_{CC}	V
Input Termination to V_{CC}	R_{IN}		40	50	60	Ω
REFERENCE CLOCK INPUT (REFCLK+, REFCLK-) (Note 1)						
Differential Input Voltage		AC-coupled or DC-coupled input	300		1600	mVp-p
LVPECL Input High Voltage			$V_{CC} - 1.16$		$V_{CC} - 0.88$	V
LVPECL Input Low Voltage			$V_{CC} - 1.81$		$V_{CC} - 1.48$	V
LVPECL Input Bias Voltage				$V_{CC} - 1.3$		V
Differential Input Impedance				2.6		k Ω
OUTPUT SPECIFICATION (PDO[15..0]\pm, PCLKO\pm)						
LVDS Output High Voltage	V_{OH}				1.475	V
LVDS Output Low Voltage	V_{OL}		0.925			V
LVDS Differential Output Voltage	$ V_{OD} $		250		400	mV
LVDS Change in Magnitude of Differential Output for Complementary States	$ \Delta V_{OD} $				25	mV
LVDS Offset Output Voltage	V_{OD}		1.125		1.275	V
LVDS Change in Magnitude of Output Offset Voltage for Complementary States	$ \Delta V_{OD} $				25	mV
LVDS Differential Output Impedance			80		140	Ω
LVDS Output Current		Short together or short to GND			20	mA

10Gbps 1:16 Deserializer with Clock Recovery

MAX3953

DC ELECTRICAL CHARACTERISTICS (continued)

($V_{CC} = +3.0V$ to $+3.6V$, $T_A = 0^{\circ}C$ to $+85^{\circ}C$. Typical values are at $+3.3V$ and $T_A = +25^{\circ}C$, unless otherwise noted.)

PARAMETER	SYMBOL	CONDITIONS	MIN	TYP	MAX	UNITS
LVTTTL INPUT AND OUTPUT (CLKSEL, SYN_ERR, RATESET, LOS_IN, LOL, REFSET)						
LVTTTL Input High Voltage	V_{IH}		2			V
LVTTTL Input Low Voltage	V_{IL}				0.8	V
LVTTTL Input Current			-50		+6	μA
LVTTTL Output High Voltage	V_{OH}	$I_{OH} = 20\mu A$	2.4		V_{CC}	V
LVTTTL Output Low Voltage	V_{OL}	$I_{OL} = 1mA$			0.4	V

Note 1: Reference clock duty cycle can range from 30% to 70%.

AC ELECTRICAL CHARACTERISTICS

($V_{CC} = +3.0V$ to $+3.6V$, $T_A = 0^{\circ}C$ to $+85^{\circ}C$. Typical values are at $+3.3V$ and $T_A = +25^{\circ}C$, unless otherwise noted.) (Note 2)

PARAMETER	SYMBOL	CONDITIONS	MIN	TYP	MAX	UNITS
Serial Input Data Rate		RATESET = GND		9.953		Gbps
		RATESET = V_{CC}		10.3125		
Sinusoidal Jitter Tolerance		$f = 400kHz$ (Notes 3, 4)		1.5		UIp-p
		$f = 4MHz$ (Note 3)		0.15		
Tolerated Consecutive Identical Digits		Bit-error ratio (BER) = 10-12		2000		Bits
Input Return Loss		$f < 10GHz$, differential		10		dB
		$f < 15GHz$, differential		8		
		$f < 15GHz$, common mode		9		
Frequency Difference when PLL Indicates Out of Lock				1000		ppm
Frequency Difference when PLL Indicates In Lock				500		ppm
LOL Assert Time		No transitions at input, Figure 2		30	100	μs
PLL Acquisition Time		Valid transitions at input, Figure 2			100	μs
Maximum PCLKO Deviation from REFCLK					2500	ppm
Output Clock to Data Delay	t_{CLK-Q}	Figure 3	-150		+150	ps
Output Clock Duty Cycle			45	50	55	%

10Gbps 1:16 Deserializer with Clock Recovery

AC ELECTRICAL CHARACTERISTICS

($V_{CC} = +3.0V$ to $+3.6V$, $T_A = 0^\circ C$ to $+85^\circ C$. Typical values are at $+3.3V$ and $T_A = +25^\circ C$, unless otherwise noted.) (Note 2)

PARAMETER	SYMBOL	CONDITIONS	MIN	TYP	MAX	UNITS
Output Clock and Data Rise/Fall Time	t_R, t_F	20% to 80%	100		250	ps
LVDS Differential Skew	t_{SKEW1}	Any differential pair			50	ps
LVDS Channel-to-Channel Skew	t_{SKEW2}	PDO[15..0] \pm			100	ps

Note 2: Guaranteed by design and characterization for $T_A = 0^\circ C$ to $+85^\circ C$.

Note 3: Measured with $0.45UI_{p-p}$ deterministic jitter and $0.15UI_{p-p}$ random jitter, on top of the specified sinusoidal jitter in a $2^{31} - 1$ PRBS pattern with a BER = 10^{-12} .

Note 4: The jitter tolerance exceeds IEEE 802.3AE specifications. The jitter tolerance outperforms the instrument's measurement capability.

Typical Operating Characteristics

($T_A = +25^\circ C$, unless otherwise noted.)

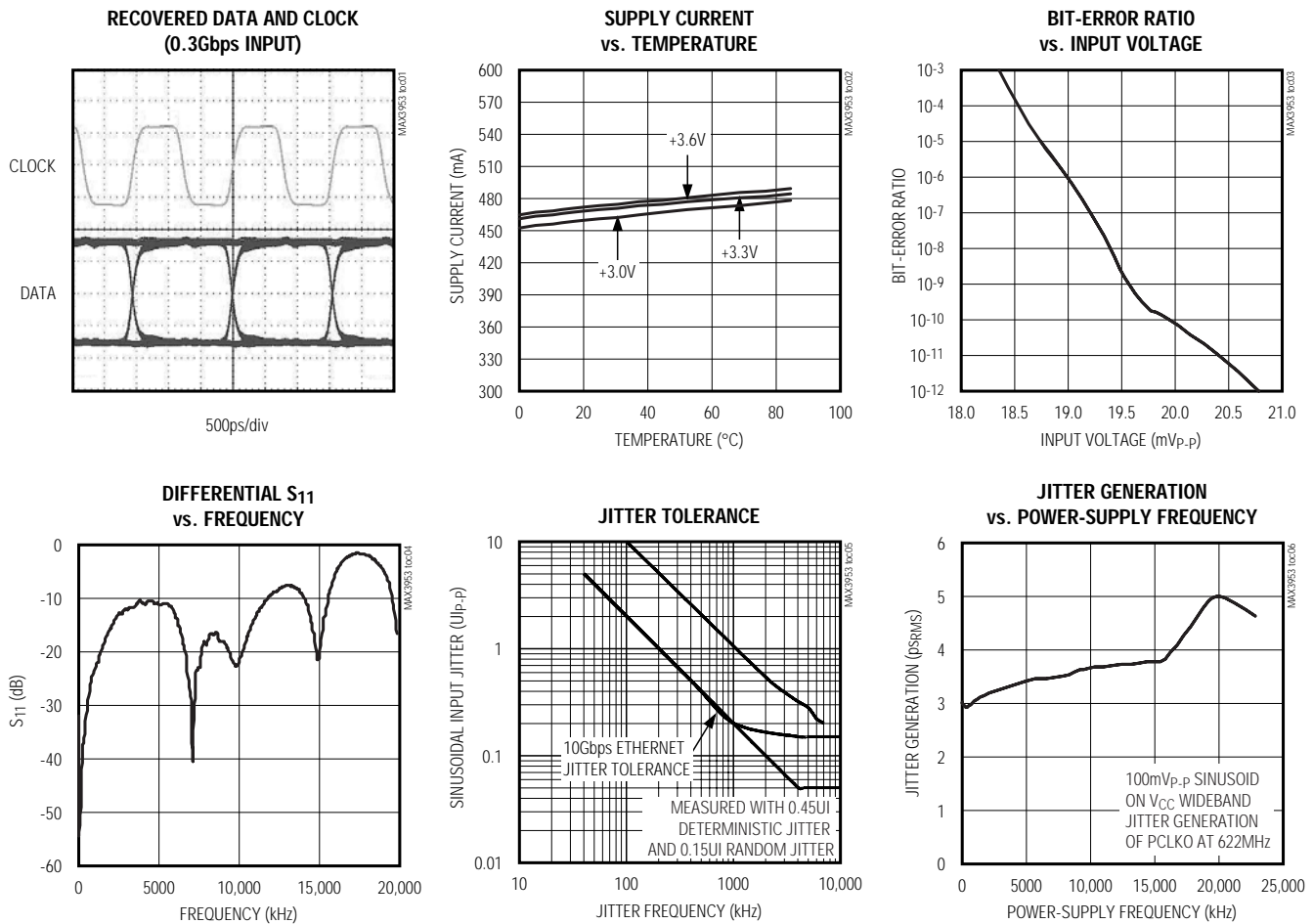

10Gbps 1:16 Deserializer with Clock Recovery

Pin Description

MAX3953

PIN	NAME	FUNCTION
1, 4, 5, 6, 14, 17, 18, 34, 35, 51, 52, 60, 68	GND	Ground
2	REFCLK+	Positive Reference Clock Input, LVPECL. Connect a baud rate/64 or baud rate/16 reference clock.
3	REFCLK-	Negative Reference Clock Input, LVPECL. Connect a baud rate/64 or baud rate/16 reference clock.
7	REFSET	Reference Clock Select Input, TTL. When the reference clock is baud rate/64, set REFSET to GND. When the reference clock is baud rate/16, set REFSET to V _{CC} .
8, 11, 12, 13, 15, 16, 27, 42, 59, 66	V _{CC}	+3.3V Supply Voltage
9	SDI+	Positive Serial Data Input, CML. 9.953Gbps/10.3125Gbps serial data stream.
10	SDI-	Negative Serial Data Input, CML. 9.953Gbps/10.3125Gbps serial data stream.
19	$\overline{\text{LOS_IN}}$	Loss-of-Signal Input, TTL. The $\overline{\text{LOS_IN}}$ is an external input. Clock holdover is activated when $\overline{\text{LOS_IN}}$ is TTL low. Connect to V _{CC} if $\overline{\text{LOS}}$ input is not available. See the <i>Acquisition Controls</i> section.
20	$\overline{\text{LOL}}$	Loss-of-Lock Indicator Output, TTL. $\overline{\text{LOL}}$ signals a TTL low when the VCO frequency is more than 1000ppm from the reference clock frequency. $\overline{\text{LOL}}$ signals a TTL high when the VCO frequency is within 500ppm of the reference clock frequency. See the <i>Acquisition Controls</i> section.
21	PCLKO+	Positive Parallel Clock Output, LVDS
22	PCLKO-	Negative Parallel Clock Output, LVDS
23, 25, 28, 30, 32, 36, 38, 40, 43, 45, 47, 53, 55, 57, 61, 63	PDO15+ to PDO0+	Positive Parallel Data Outputs, LVDS
24, 26, 29, 31, 33, 37, 39, 41, 44, 46, 48, 54, 56, 58, 62, 64	PDO15- to PDO0-	Negative Parallel Data Outputs, LVDS
49	SYNC_ERR	Synchronization Error Output, TTL. SYNC_ERR is intended to drive CLKSEL for acquisition. See the <i>Acquisition Controls</i> section.
50	CLKSEL	Output Clock Selector, TTL. CLKSEL is the control input for acquisition. When CLKSEL = GND, PCLKO is derived from the input data. When CLKSEL = V _{CC} , PCLKO is derived from the reference clock.
65	RATESET	Serial Data Rate Select Input, TTL. When the input serial data stream is 9.953Gbps, set RATESET to GND. When the input serial data stream is 10.312Gbps, set RATESET to V _{CC} .
67	FIL	PLL Loop Filter Capacitor Input. A capacitor between this pin and V _{CC} sets the loop to zero. A 0.047 μ F capacitor is recommended.
EP	Exposed Pad	Ground. This must be soldered to the circuit board ground for proper thermal and electrical performance. See the <i>Layout Considerations</i> section.

10Gbps 1:16 Deserializer with Clock Recovery

Detailed Description

The MAX3953 deserializer with clock recovery converts 9.953Gbps/10.3125Gbps serial data into 16-bit wide, 622Mbps/644Mbps parallel data. The device combines a fully integrated phase-locked loop (PLL), TTL-compatible status monitors, input amplifier, data retiming block, 16-bit demultiplexer, clock dividers, and LVDS output buffers. The PLL consists of a phase/frequency detector (PFD), a loop filter, and voltage-controlled oscillator (VCO). The PLL recovers the serial clock from the input data stream and retimes the data. The demultiplexer generates a 16-bit-wide 622Mbps/644Mbps parallel data output. The MAX3953 is designed to deliver the best jitter performance by using differential signal architecture and low-noise design techniques.

Input Amplifier

The serial data input (SDI) amplifier accepts differential input amplitudes from 100mV_{P-P} to 1200mV_{P-P}.

Phase-Frequency Detector

The digital phase-frequency detector (PFD) aids frequency acquisition during startup conditions. Depending on the polarity of the frequency input difference between REFCLK and the VCO clock, the PFD drives the VCO until the frequency difference is reduced to zero. False locking is eliminated by this digital phase-frequency detector.

The data phase detector is optimized to achieve 0.75UI high-frequency jitter tolerance.

Loop Filter and VCO

The phase detector and frequency detector outputs are summed into the loop filter. A 0.047μF capacitor (C_F) is required to set the PLL damping ratio. The loop filter output controls the on-chip VCO.

Loss-of-Lock Monitor

A loss-of-lock ($\overline{\text{LOL}}$) monitor is included in the MAX3953 frequency detector. A loss-of-lock condition is signaled with a TTL low. When the PLL is frequency locked, $\overline{\text{LOL}}$ switches to TTL high in approximately 56μs.

$\overline{\text{LOL}}$ signals a TTL low when the VCO frequency is more than 1000ppm from the reference clock frequency. $\overline{\text{LOL}}$ signals a TTL high when the VCO frequency is within 500ppm of the reference clock frequency.

Low-Voltage Differential Signal (LVDS) Outputs

The MAX3953 features LVDS outputs for interfacing with high-speed circuitry. The LVDS standard is based on the IEEE 1596.3 LVDS specification. This technology uses 500mV_{P-P} to 800mV_{P-P} differential low-voltage swings to achieve fast transition times, minimize power dissipation, and improve noise immunity.

Applications Information

Acquisition Controls

The MAX3953 has two phase-detector circuits, a Bang-Bang phase detector to lock the VCO to the serial input data (BB_PD), and a phase detector to lock the VCO to the reference clock (REF_PD). The pull-in range for the REF_PD is wide enough to accommodate the VCO turning range across the two valid data rates, while the pull-in range for the BB_PD is narrow. The REF_PD is activated by CLKSEL = HIGH. The BB_PD is activated by CLKSEL = LOW. For the MAX3953 CDR to lock to the serial input data, the frequency of the VCO must be pulled within 500ppm of the input data rate by first locking the VCO to the reference clock (RECLK) via the REF_PD. Once the VCO is within 500ppm, control can be transferred to the BB_PD.

For normal operation, connect the SYNC_ERR output to the CLKSEL input. This will force CLKSEL high when the MAX3953 frequency detector indicates that the VCO frequency is more than 500ppm from the REFCLK frequency. Once the VCO is pulled to within 500ppm of the REFCLK frequency, SYNC_ERR (and thus CLKSEL) will go low and the MAX3953 will lock to the SDI data stream.

If a loss-of-signal ($\overline{\text{LOS}}$) input from the system is available to the MAX3953, a clock holdover operation can be implemented by connecting the $\overline{\text{LOS}}$ output to the $\overline{\text{LOS_IN}}$ input. This will force the PLL to lock to REFCLK whenever the incoming data is lost. This keeps the frequency of PCLKO from drifting during a loss-of-signal condition. If the $\overline{\text{LOS}}$ signal from the system is not available, or if the clock-holdover mode is not required, the $\overline{\text{LOS_IN}}$ must be connected to VCC to disable the function.

Consecutive Identical Digits (CIDs)

The MAX3953 has a low phase and frequency drift in the absence of data transitions. As a result, long runs of consecutive zeros and ones can be tolerated while maintaining a BER of 1×10^{-12} . The CID tolerance is tested using a $2^{13} - 1$ pseudorandom bit stream (PRBS), substituting a long run of zeros to simulate worst case. A CID tolerance of greater than 2,000 bits is typical.

Exposed-Pad Package

The exposed pad, 68-pin QFN incorporates features that provide a very low thermal-resistance path for heat removal from the IC. The pad is electrical ground on the MAX3953 and should be soldered to the circuit board for proper thermal and electrical performance. See Maxim Application Note HFAN-08.1: *Thermal Considerations of QFN and Other Exposed-Paddle Packages* for further information.

10Gbps 1:16 Deserializer with Clock Recovery

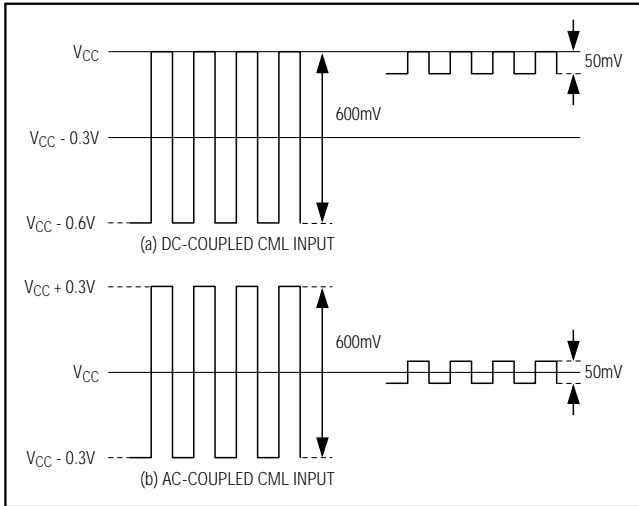

Figure 1. Input Amplitude

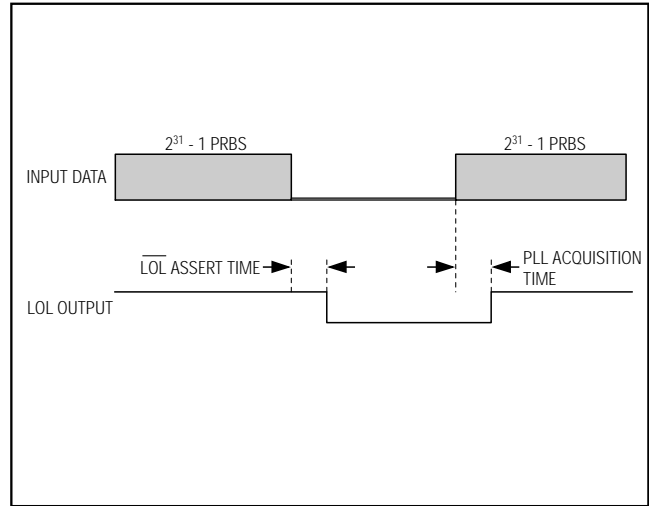

Figure 2. $\overline{\text{LOL}}$ Assert and Acquisition Time

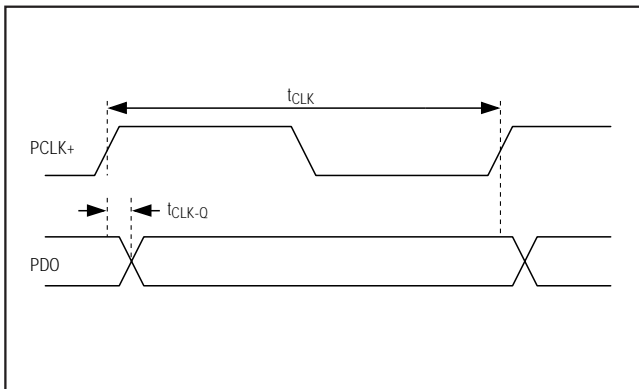

Figure 3. Timing Parameters

Layout Techniques

For best performance, use good high-frequency layout techniques. Filter voltage supplies, keep ground connections short, and use multiple vias where possible. Use controlled-impedance transmission lines to interface with the MAX3953 high-speed inputs and outputs. Power-supply decoupling should be placed as close to the V_{CC} as possible. To reduce feed-through, isolate input signals from output signals.

10Gbps 1:16 Deserializer with Clock Recovery

MAX3953

Functional Diagram

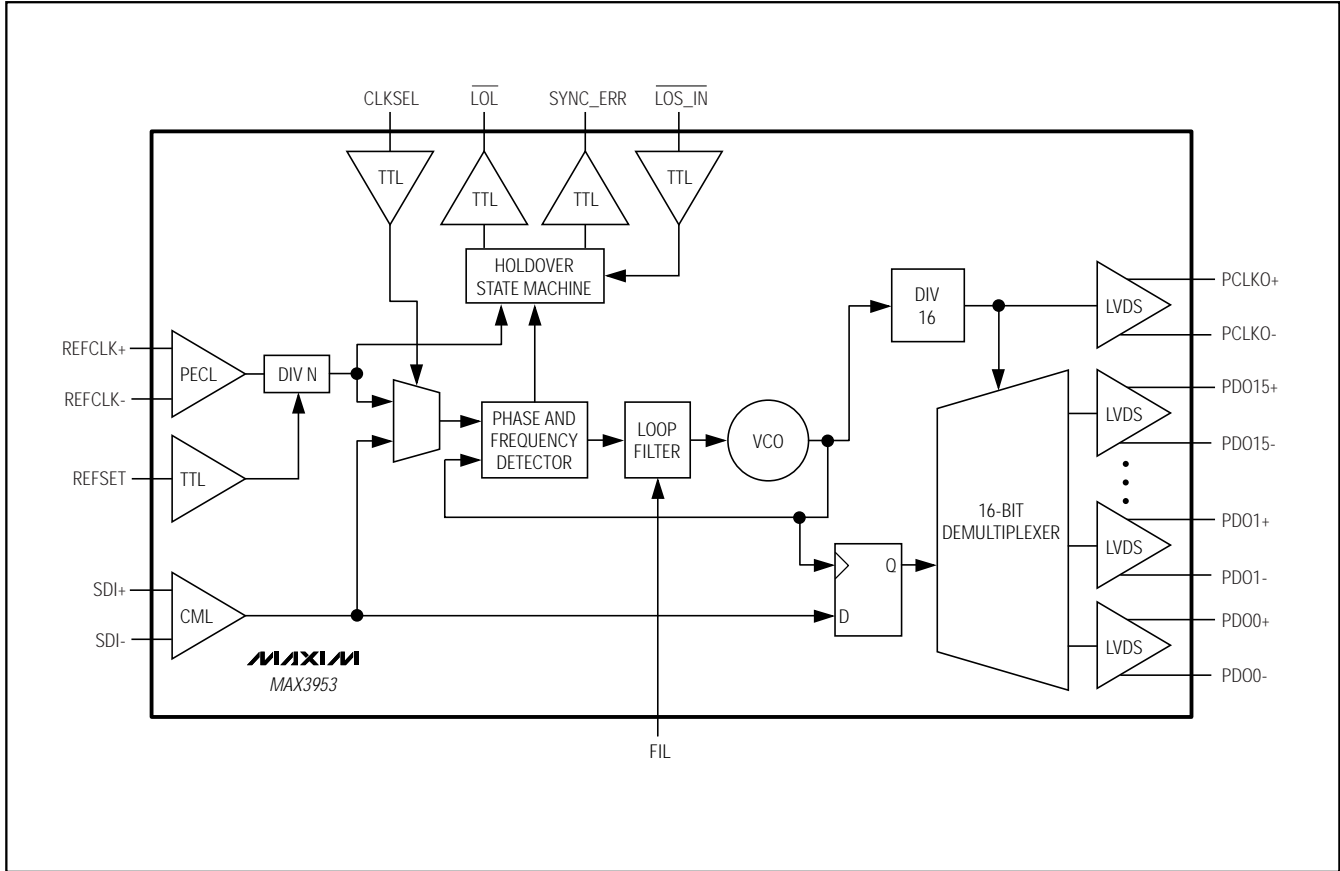

10Gbps 1:16 Deserializer with Clock Recovery

Pin Configuration

MAX3953

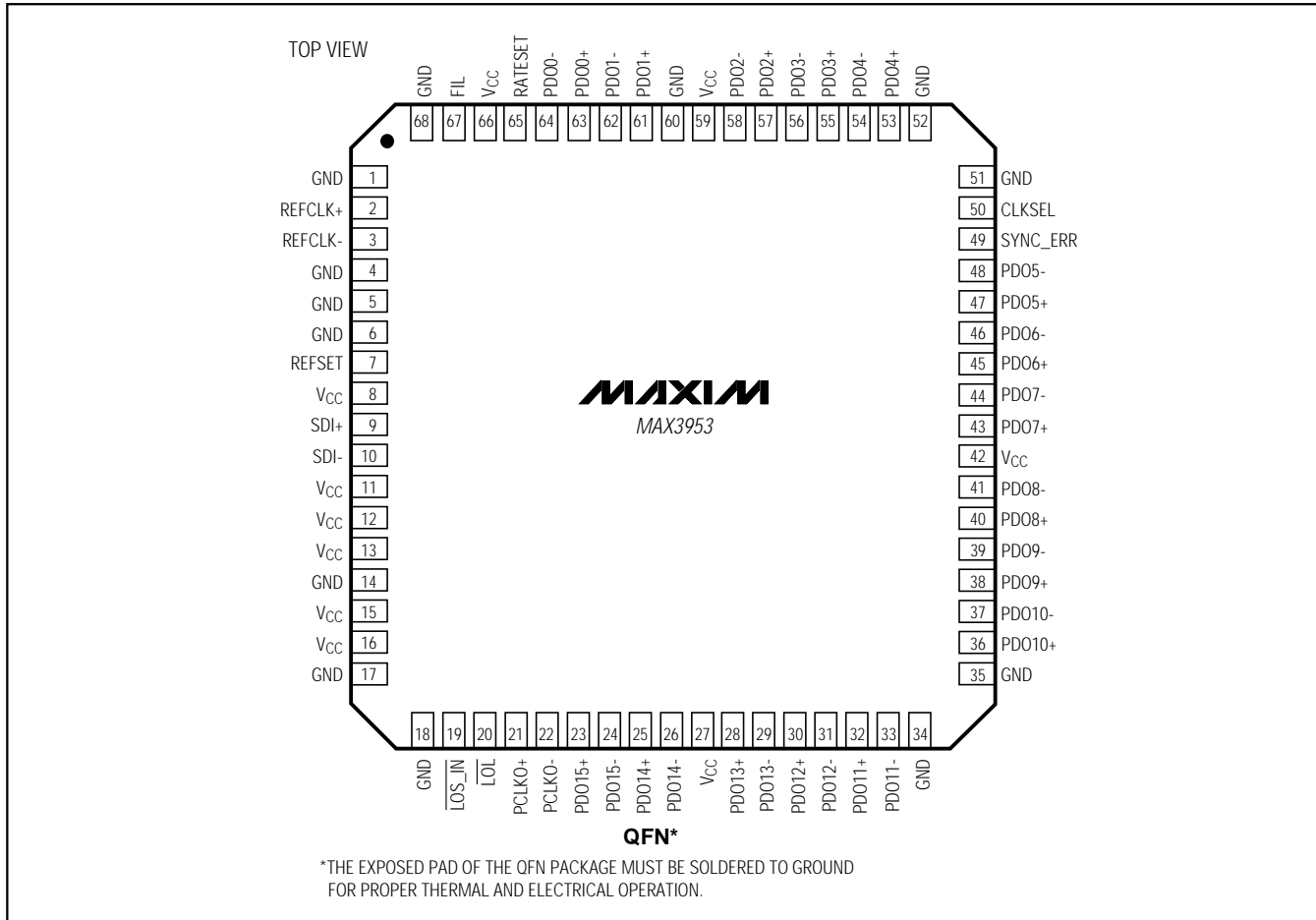

Chip Information

TRANSISTOR COUNT: 11,612

PROCESS: SiGe BIPOLAR

10Gbps 1:16 Deserializer with Clock Recovery

Package Information

(The package drawing(s) in this data sheet may not reflect the most current specifications. For the latest package outline information go to www.maxim-ic.com/packages.)

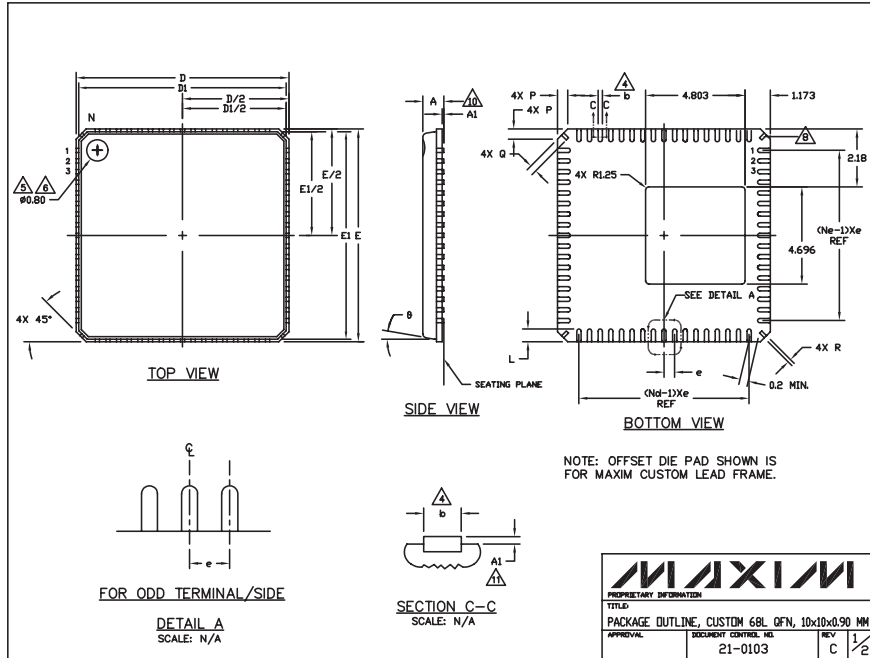

NOTES:

- DIE THICKNESS ALLOWABLE IS .012 INCHES MAXIMUM.
- DIMENSIONING & TOLERANCES CONFORM TO ASME Y14.5M. - 1994.
- N IS THE NUMBER OF TERMINALS.
 N_d IS THE NUMBER OF TERMINALS IN X-DIRECTION &
 N_e IS THE NUMBER OF TERMINALS IN Y-DIRECTION.
- DIMENSION b APPLIES TO PLATED TERMINAL AND IS MEASURED BETWEEN 0.20mm AND 0.25mm FROM TERMINAL.
- THE PIN #1 IDENTIFIER MUST BE LOCATED ON THE TOP SURFACE OF THE PACKAGE BY USING INDENTATION MARK OR OTHER FEATURE OF PACKAGE BODY.
- EXACT SHAPE AND SIZE OF THIS FEATURE IS OPTIONAL.
- ALL DIMENSIONS ARE IN MILLIMETERS.
- THE SHAPES SHOWN AT FOUR CORNERS ARE CONNECTED TO DIE PAD.
- PACKAGE WARPAGE MAX 0.10mm.
- APPLIED FOR EXPOSED PAD AND TERMINALS.
- APPLIED ONLY FOR TERMINALS.
- CUSTOM LEAD FRAME WITH OFFSET DIE PAD: REFER TO MAXIM 24-0718 (06800-1F).

SYMBOL	COMMON DIMENSIONS			N _d × N _e
	MIN.	NOM.	MAX.	
A	-	0.90	1.00	
A1	0.00	0.01	0.05	11
b	0.18	0.23	0.30	4
D	10.00BSC			
D1	9.75BSC			
F	10.00BSC			
E1	9.75BSC			
N	68			3
N _d	17			3
N _e	17			3
Ø	0.50 BSC			
L	0.50	0.60	0.75	
Ø	12°			
P	0.24	0.42	0.60	
Q	0.30	0.40	0.65	
R	0.13	0.17	0.23	

MAXIM			
PROPRIETARY INFORMATION			
TITLE: PACKAGE OUTLINE, CUSTOM 6BL GFN, 10x10x0.90 MM			
APPROVAL:	DOCUMENT CONTROL NO:	REV:	C
	21-0103	2/2	

Maxim cannot assume responsibility for use of any circuitry other than circuitry entirely embodied in a Maxim product. No circuit patent licenses are implied. Maxim reserves the right to change the circuitry and specifications without notice at any time.

10 _____ Maxim Integrated Products, 120 San Gabriel Drive, Sunnyvale, CA 94086 408-737-7600