

Helping Customers Innovate, Improve & Grow



## Description

The FX-702 is a low jitter precision frequency translator used to translate input frequencies such as 19.44, 38.88, 77.76 MHz, etc. to a binary multiple frequency as high as 850 MHz. The FX-702's superior jitter performance is achieved through the PLL's integrated VCISO. The FX-702 is housed in a hermetically sealed leadless surface mount package offered on tape and reel.

## Features

- 5 x 7.5 x 2.5 mm Package
- Frequency Translation up to 850 MHz
- VCISO based PLL for Ultra-Low Jitter
- CMOS / LVDS / LVPECL Inputs compatible
- Differential LVPECL or LVDS Output
- CMOS Lock Detect
- External Divider for Input Frequencies < 19 MHz
- 0°/70°C or -40°/+85°C Temperature Range
- Fully Compatible for Lead Free Assembly 

## Applications

- SONET/SDH
- 10GbE./10.3GbE
- Frequency Translation
- Clock Smoothing, Clock Switching
- FEC Scaling
- Medical Instrumentation
- Test and Measurement
- Military

## Block Diagram

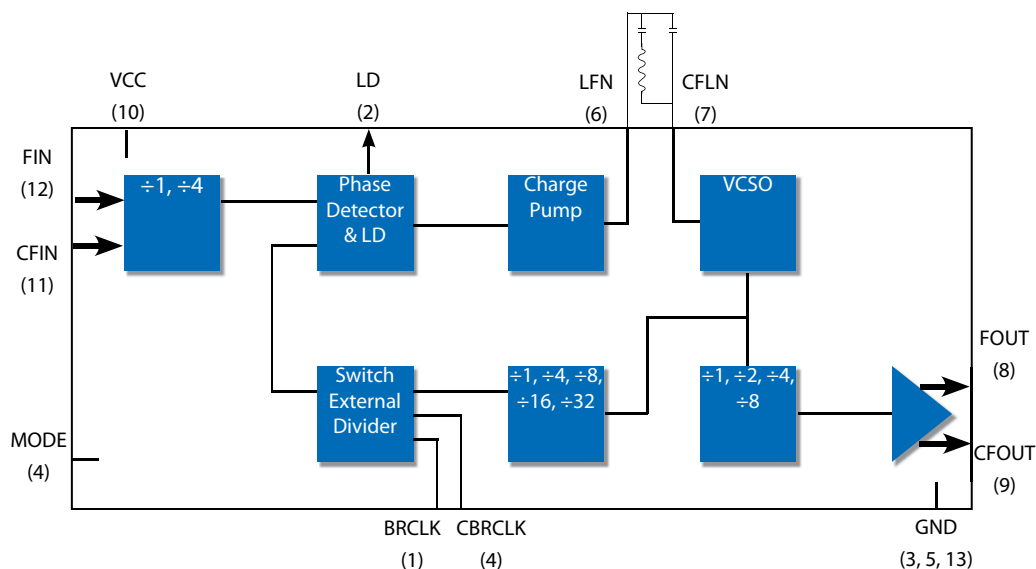

Figure 1. Functional block diagram

# Performance Specifications

Table 1. Electrical Performance					
Parameter	Symbol	Min	Typical	Maximum	Units
Frequency <sup>1,2,3</sup>					
Input Frequency	$F_{IN}$	1		850	MHz
Output Frequency	$F_{OUT}$	62.5		850	MHz
Capture Range (ordering option) <sup>1,2,3</sup>	APR	±32, ±50, or ±100			ppm
Supply					
Voltage <sup>2,3</sup>	$V_{CC}$	2.97	3.3	3.63	V
Current (No Load) <sup>3</sup>	$I_{CC}$			100	mA
LVC MOS Input <sup>2,3</sup>					
Input High Voltage	$V_{IH}$	2.0		$V_{CC}$	V
Input Low Voltage	$V_{IL}$	0		0.8	V
LVPECL Input					
Peal-Peak Amplitude Swing <sup>6,7</sup>		0.20		3.00	V
Lock Detect Output					
Output High Voltage	$V_{OH}$	$0.9 \cdot V_{CC}$			V
Logic Low Voltage	$V_{OL}$			$0.1 \cdot V_{CC}$	V
Outputs					
Mid Level - LVPECL <sup>2,3</sup>		$V_{CC}-1.5$	$V_{CC}-1.3$	$V_{CC}-1.1$	V
Single Ended Swing - LVPECL <sup>2,3</sup>			750		mV-pp
Differential Swing - LVPECL <sup>2,3</sup>			1.5		V-pp
Mid Level - LVDS <sup>2,3</sup>			$V_{CC}-1.2$		V
Single Ended Swing - LVDS <sup>2,3</sup>			450		mV-pp
Current <sup>5</sup>	$I_{OUT}$			20	mA
Rise Time <sup>4,5</sup>	$t_R$			400	ps
Fall Time <sup>4,5</sup>	$t_F$			400	ps
Symmetry <sup>2,3</sup>	SYM	45	50	55	%
Jitter Generation - 622.08MHz output (12kHz-20MHz BW) <sup>5</sup>	$\Phi_J$		0.21	0.5	ps-rms
(50kHz - 80MHz BW) <sup>5</sup>	$\Phi_J$		0.12	0.4	ps-rms
Operating Temp (ordering option) <sup>1,3</sup>	$T_{OP}$	0/70, -40/85			°C

1. See Standard Frequencies and Ordering Information.
2. Parameters are tested with production test circuit below (Fig 1).
3. Parameters are tested at ambient temperature with test limits guard banded for specified operating temperature.
4. Measured from 20% to 80% of a full output swing (Fig 2).
5. Not tested in production, guaranteed by design, verified at qualification.
6. Minimum Input Low Voltage not to exceed 2.125 V. Minimum Input High Voltage not to go below 1.49 V.
7. AC coupling is recommended. There is an internal pull-up and pull-down resistor on all clock inputs (Fin, BRCLK).
8. Measured using a Wavcrest SIA3300. Best results are realized with a differential input.

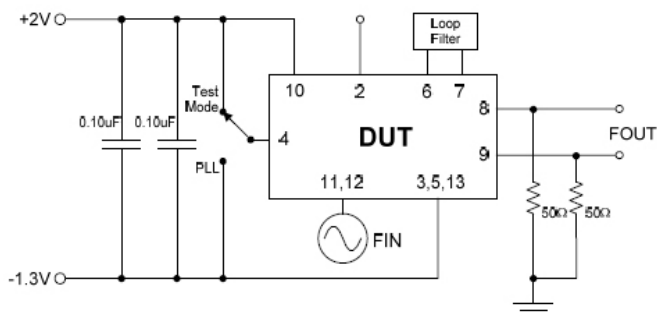

Figure 1. LVPECL Test Circuit

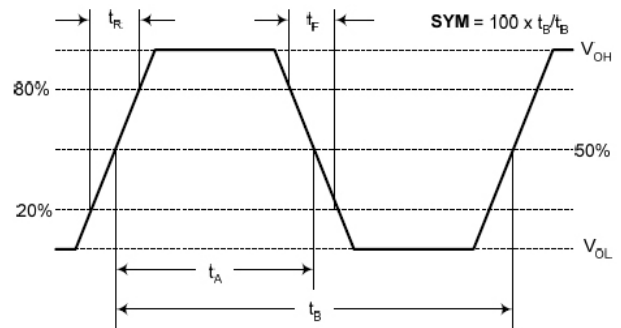

Figure 2. 10K LVPECL Waveform

## Absolute Maximum Ratings

Stresses in excess of the absolute maximum ratings can permanently damage the device. Functional operation is not implied at these or any other conditions in excess of conditions represented in the operational sections of this data sheet. Exposure to absolute maximum ratings for extended periods may adversely affect device reliability.

**Table 2. Absolute Maximum Ratings**

Parameter	Symbol	Ratings	Unit
Power Supply	$V_{CC}$	0 to 6	V
Input Current	$I_{IN}$	100	mA
Output Current	$I_{OUT}$	25	mA
Storage Temperature	$T_{STR}$	-55 to 125	°C
Soldering Temperature/Duration	$T_{PEAK}/t_P$	260 / 40	°C/sec

## Reliability

The FX-702 is capable of meeting the following qualification tests:

**Table 3. Environmental Compliance**

Parameter	Conditions
Mechanical Shock	MIL-STD-883, Method 2002
Mechanical Vibration	MIL-STD-883, Method 2007
Solderability	MIL-STD-883, Method 2003
Gross and Fine Leak	MIL-STD-883, Method 1014
Resistance to Solvents	MIL-STD-883, Method 2016
Moisture Sensitivity Level Rating	MSL 1

## Handling Precautions

Although ESD protection circuitry has been designed into the the FX-702, proper precautions should be taken when handling and mounting. VI employs a Human Body Model (HBM) and a Charged Device Model (CDM) for ESD susceptibility testing and design protection evaluation. ESD thresholds are dependent on the circuit parameters used to define the model.

**Table 4. Predicted ESD R\$atings**

Model	Class	Minimum	Conditions
Human Body Model	2	2000 V	MIL-STD 883, Method 3015
Charged Device Model	C5	1000 V	JEDEC, JESD22-C101
Machine Model	M3	200 V	ESD STM5.2-1999

**Table 5. Reflow Profile (IPC/JEDEC J-STD-020C)**

Parameter	Symbol	Value
PreHeat Time	$t_s$	60 sec Min, 180 sec Max
Ramp Up	$R_{UP}$	3 °C/sec Max
Time Above 217 °C	$t_L$	60 sec Min, 150 sec Max
Time To Peak Temperature	$t_{AMB-P}$	480 sec Max
Time At 260 °C	$t_p$	20 sec Min, 40 sec Max
Ramp Down	$R_{DN}$	6 °C/sec Max

The device has been qualified to meet the JEDEC standard for Pb-Free assembly. The temperatures and time intervals listed are based on the Pb-Free small body requirements. The temperatures refer to the topside of the package, measured on the package body surface. The FX-702 device is hermetically sealed so an aqueous wash is not an issue.

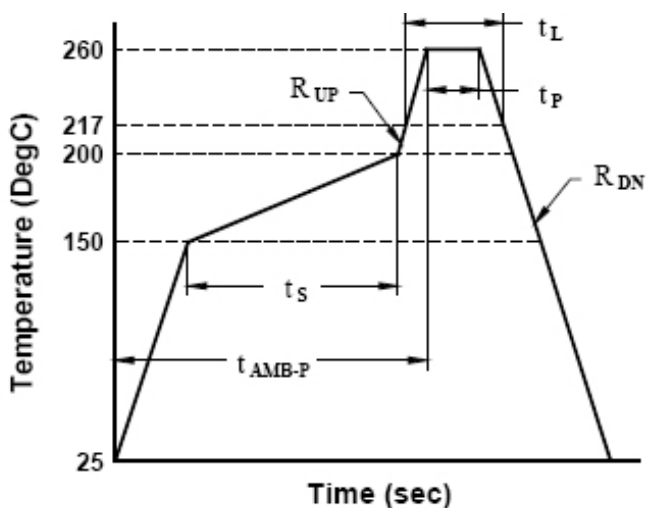

Figure 3. Suggested IR Profile

**Table 6. Tape and Reel Information**

Tape Dimensions (mm)					Reel Dimensions (mm)							
W	F	Do	Po	P1	A	B	C	D	N	W1	W2	#/Reel
16	7.5	1.5	4	8	178	1.5	13	20.2	50	16.4	22.4	200

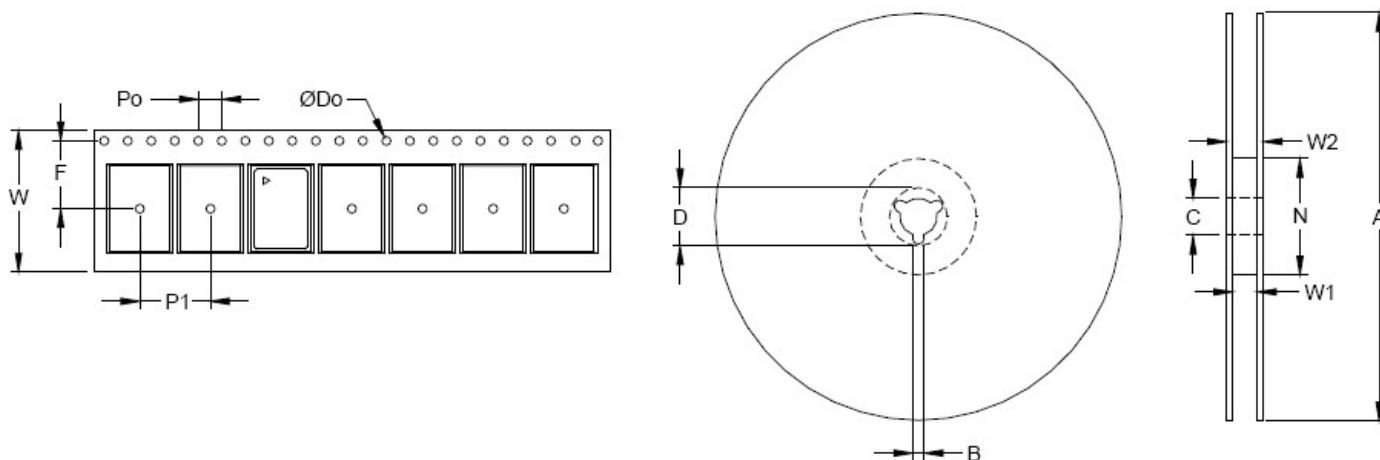

Figure 4. Tape and Reel

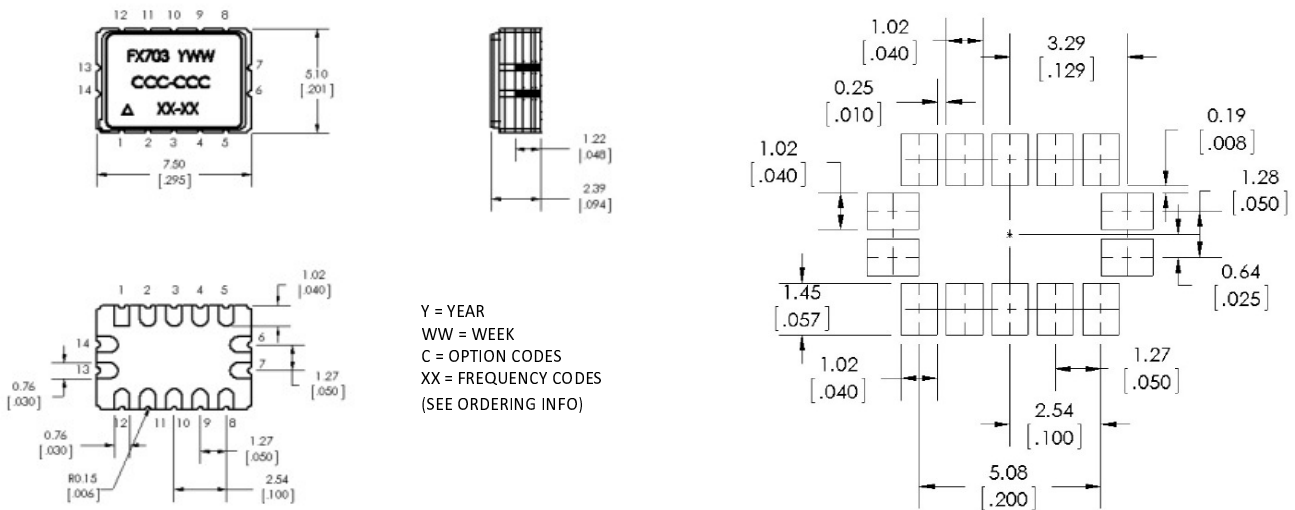

Figure 5. Outline Diagram & Suggested Pad Layout

Table 7. Pin Functions				
Pad #	Symbol	I/O	Level	Function
1	BRCLK	I	NC or LVPE-CL, LVDS	NC or For External divider application = PD Feedback Frequency
2	LD <sup>1</sup>	O	CMOS	Lock Detect Logic 0 = FX Locked Logic 1 - No Input Output transitioning = Out of Lock
3	GND	GND	Supply	Case and electrical ground
4	MODE <sup>2</sup>	I	CMOS	FX Operating Mode Logic 0 = Standard PLL (Normal Setting) Logic 1 = FIN coupled to FOUT
5	GND	GND	Supply	Case and electrical ground
6	LFN		Analog	Loop Filter Node
7	CLFN		Analog	Complementary Loop Filter Node
8	FOUT	O	LVPECL or LVDS	Frequency Output
9	CFOUT	O	LVPECL or LVDS	Complementary Frequency Output
10	VCC	I	Supply	Power Supply Voltage (+3.3V ±5%)
11	CFIN <sup>4,5</sup>	I	LVPECL	Complementary Input Frequency For CMOS inouts, AC-couple unused input to ground or negative supply
12	FIN <sup>4,5</sup>	I	CMOS or LVPECL	Input Frequency
13	GND	GND	Supply	Case and electrical ground
14	CBRCLK <sup>3,4</sup>	I	NC or LVPE-CL, LVDS	NC or For External divider applications = Comp. PD Feedback Frequency

1. It is recommended that a buffer driver is used for best noise isolation.
2. Do not leave the MODE pin floating, it should be set to logic 0 or ground for normal operation.
3. BRCLK and CBRCLK should be left floating if not used.
4. FIN, CFIN, BRCLK, and CBRCLK have internal pull-up/pull-down resistors and it is recommended to AC couple these inputs.
5. Best jitter is realized with a differential input.

**Table 8. Standard Frequencies (MHz)**

18.7500000	EE	39.0625000	HH	73.7280000	K8	172.500000	NU	600.000000	PR	779.568600	T8
19.2000000	DD	39.3216000	HD	74.1250000	K1	173.370748	ND	614.400000	RG	780.881000	TD
19.3926580	DX	39.8437500	HJ	74.1758000	KA	173.437500	NP	622.080000	P2	781.250000	T9
19.4400000	D6	40.0000000	JF	74.2500000	K7	176.838175	NA	624.693800	PD	796.875000	TB
19.5312500	DZ	40.2830630	KK	75.0000000	KH	182.016000	N8	624.704800	P6	800.000000	TK
19.6608000	DB	40.9600000	J1	76.8000000	K4	182.857142	NM	625.000000	P3	805.664100	TA
19.6989680	DK	41.0888870	KM	77.7600000	K2	184.000000	NG	627.329600	P7	809.063500	TE
19.7190000	DH	41.6571440	KP	78.0000000	LH	184.320000	NH	629.987800	PA	819.200000	TH
19.9218750	ED	41.6600000	LM	78.1250000	K3	187.500000	N5	637.500000	PG	821.777300	TF
20.0000000	E2	41.8329130	KT	78.6432000	K5	195.000000	N7	640.000000	PN	850.000000	TJ
20.1416000	E3	42.0000000	JB	79.6875000	KG	200.000000	NE	644.531250	P4	983.400000	TU
20.4800000	E4	42.0101690	KV	80.0000000	K9	200.192000	N6	645.120000	RJ	1,000.0000	TM
20.5444340	EF	42.5000000	JC	80.5664130	KJ	201.416020	N1	647.239400	PE		
20.7135000	E1	42.6600000	JZ	82.1777380	KL	212.500000	NF	647.250800	PK		
20.8285720	EG	44.2095440	KX	82.9440000	K6	219.429571	NL	649.970300	PF		
20.8286000	EB	44.4343000	LF	83.3142880	KN	240.000000	NR	657.421875	PB		
20.9165460	EH	44.6218000	JW	83.6658250	KR	243.000000	NC	665.625600	PC		
21.0050840	EJ	44.7360000	J3	84.0203380	KU	245.760000	N9	666.514286	P5		
22.0000000	E9	44.9280000	JE	86.6853740	LJ	250.000000	NT	669.128100	R2		
22.1047720	EK	45.1584000	JG	88.4190880	KW	252.571428	NJ	669.326582	R3		
22.2171000	E5	45.8240000	JM	95.7000000	LK	256.000000	NK	669.642900	R1		
22.5792000	E8	46.0379460	LG	97.5000000	KE	262.144000	NB	670.838600	R7		
24.0000000	EC	46.7200000	JK	100.000000	L8	292.571429	NN	672.000000	RT		
24.5760000	E6	46.8750000	JY	105.000000	L6	300.000000	PT	672.156250	TX		
24.7040000	E7	48.0000000	JV	106.250000	L9	307.200000	RX	672.162712	R5		
25.0000000	F7	49.1520000	J7	108.000000	LA	311.040000	P1	673.456600	RA		
25.1658000	F8	49.4080000	J2	110.000000	L1	312.500000	PU	684.255400	R9		
25.6000000	F6	50.0000000	JD	112.000000	L2	318.750000	PV	687.700000	TV		
25.9200000	F2	50.0480000	KD	114.000000	L3	320.000000	PP	690.569196	R4		
26.0000000	F3	51.2000000	LL	120.000000	LC	322.265650	PW	693.468750	RV		
27.0000000	F4	51.8400000	J4	122.880000	LB	328.710950	PX	693.482991	R6		
27.6480000	FB	52.0000000	JP	124.416000	L7	333.257150	PY	693.750000	R8		
28.7040000	F1	53.3300000	JU	125.000000	L4	333.625806	VX	696.390625	RW		
29.4912000	F5	54.7460000	JL	130.000000	LD	334.663300	RB	696.421478	V1		
29.5000000	F9	55.0000000	JX	131.072000	LN	336.081350	RC	696.421875	TY		
30.0000000	HE	60.0000000	JR	139.264000	L5	353.676350	RD	704.380600	TG		
30.7200000	H1	61.3800000	KY	150.000000	M8	368.640000	RY	707.352700	TC		
30.8800000	HF	61.4400000	J5	150.144000	M6	375.000000	RF	707.500000	V2		
31.2500000	H8	62.2080000	J8	153.600000	MA	382.800000	RU	710.948600	T2		
32.0000000	H2	62.5000000	J9	155.520000	M2	400.000000	RR	712.520000	TW		
32.7680000	H3	62.9145000	LE	156.250000	M3	409.600000	RE	716.573200	T1		
33.0000000	H7	63.3600000	JJ	159.375000	M7	491.520000	PM	718.750000	T5		
33.3330000	HC	63.8976000	JN	160.000000	M1	500.000000	RK	719.734400	T3		
34.3680000	H6	64.0000000	JT	161.132813	M4	505.000000	V3	737.280000	TL		
34.5600000	HB	64.1520000	JH	164.355475	M9	531.000000	PH	739.200000	TT		
36.8640000	HG	65.5360000	J6	166.628572	M5	531.250000	P8	742.500000	V4		
37.0560000	H4	66.0000000	JA	166.812903	NY	568.928600	PJ	748.070900	T6		
37.1250000	H9	70.0000000	KB	167.331646	N2	569.196400	P9	750.000000	T7		
37.5000000	HK	70.6560000	KC	168.040678	N3	588.000000	RH	768.000000	TN		
38.8800000	H5	71.6100000	KF	170.000000	N4	595.056000	PL	777.600000	T4		

## Ordering Information

# FX-702 - E C E - H M M M - XX - XX

**Product Family**

FX: Frequency Translator

**Package**

702: 5.0 x 7.5 x 2.0mm

**Input**

E: 3.3 Vdc ±10%

**Output**

C: LVPECL

D: LVDS

**Operating Temperature**

E: -40 to 85 °C

T: 0 to 70 °C

**Absolute Pull Range**

E: ± 20 ppm

H: ± 32 ppm

K: ± 50 ppm

S: ± 100 ppm

**Output Frequency**  
(See Above)**Input Frequency**  
(See Above)**Prescaler**

M: Factory Set

**Output 2 Divider**

M: Factory Set

**Feedback Divider**

L: Disabled (external required)

M: Factory Set

1. Not all combinations are possible. Please consult with your Vectron representative for application assistance. Other frequencies available upon request.
2. When ordering the FX-702 with the external divider option, the prescaler is set to 1. The Feedback Divider =  $F_{OUT}/F_{IN}$ .

Example: FX-702-ECE-KMMM-M3-M3 (156.25 MHz Jitter Attenuator)

Example: FX-702-EDT-SLMM-F7-L4 (25 MHz to 125 MHz Frequency Translator with external divide-by-5)

Revision History		
Date	Approved	Description
15Feb2013	BW	Updated the outline diagram shown in Figure 5.
06Oct2010	BW	Updated frequency code table.
01Jun2010	BW	Added $\pm 20$ ppm APR ordering option.
12Mar2010	BW	Added the "LN" frequency code to Table 8.
09Nov2009	BW	Added divide-by-8 to output divider. Minimum output frequency reduced from 125 MHz to 62.5 MHz. Input frequency reduced from 19.44 MHz to 1 MHz. LVPECL levels clarified.

## For Additional Information, Please Contact

### USA:

Vectron International  
 267 Lowell Road  
 Hudson, NH 03051  
 Tel: 1.888.328.7661  
 Fax: 1.888.329.8328

### Europe:

Vectron International  
 Landstrasse, D-74924  
 Neckarbischofsheim, Germany  
 Tel: +49 (0) 3328.4784.17  
 Fax: +49 (0) 3328.4784.30

### Asia:

Vectron International  
 1F-2F, No 8 Workshop, No 308 Fenju Road  
 WaiGaoQiao Free Trade Zone  
 Pudong, Shanghai, China 200131  
 Tel: 86.21.5048.0777  
 Fax: 86.21.5048.1881

### Disclaimer

Vectron International reserves the right to make changes to the product(s) and/or information contained herein without notice. No liability is assumed as a result of their use or application. No rights under any patent accompany the sale of any such product(s) or information.