



PCA2129T

Accurate RTC with integrated quartz crystal for automotive

Rev. 3 — 24 January 2013

Product data sheet

1. General description

The PCA2129T is a CMOS¹ Real Time Clock (RTC) and calendar with an integrated Temperature Compensated Crystal (Xtal) Oscillator (TCXO) and a 32.768 kHz quartz crystal optimized for very high accuracy and very low power consumption. The PCA2129T has a selectable I²C-bus or SPI-bus, a backup battery switch-over circuit, a programmable watchdog function, a timestamp function, and many other features.

2. Features and benefits

- AEC-Q100 compliant for automotive applications
- Temperature Compensated Crystal Oscillator (TCXO) with integrated capacitors
- Typical accuracy: ± 3 ppm from -30 °C to $+80$ °C
- Integration of a 32.768 kHz quartz crystal and oscillator in the same package
- Provides year, month, day, weekday, hours, minutes, seconds, and leap year correction
- Timestamp function
 - ◆ with interrupt capability
 - ◆ detection of two different events on one multilevel input pin (for example, for tamper detection)
- Two line bidirectional 400 kHz Fast-mode I²C-bus interface
- 3 line SPI-bus with separate data input and output (maximum speed 6.5 Mbit/s)
- Battery backup input pin and switch-over circuitry
- Battery backed output voltage
- Battery low detection function
- Extra power fail detection function with input and output pins
- Power-On Reset Override (PORO)
- Oscillator stop detection function
- Interrupt output (open-drain)
- Programmable 1 second or 1 minute interrupt
- Programmable watchdog timer with interrupt
- Programmable alarm function with interrupt capability
- Programmable square output
- Clock operating voltage: 1.8 V to 4.2 V
- Low supply current: typical 0.70 μ A at $V_{DD} = 3.3$ V

1. The definition of the abbreviations and acronyms used in this data sheet can be found in [Section 19](#).



3. Applications

- Electronic metering for electricity, water, and gas
- Precision timekeeping
- Access to accurate time of the day
- GPS equipment to reduce time to first fix
- Applications that require an accurate process timing
- Products with long automated unattended operation time

4. Ordering information

Table 1. Ordering information

Type number	Package		
	Name	Description	Version
PCA2129T/Q900/2	SO16	plastic small outline package; 16 leads; body width 7.5 mm	SOT162-1

4.1 Ordering options

Table 2. Ordering options

Product type number	Sales item (12NC)	Orderable part number	IC revision	Delivery form
PCA2129T/Q900/2	935296923518	PCA2129T/Q900/2,51	2	tape and reel, 13 inch, dry pack

5. Marking

Table 3. Marking codes

Product type number	Marking code
PCA2129T/Q900/2	PCA2129T/Q

6. Block diagram

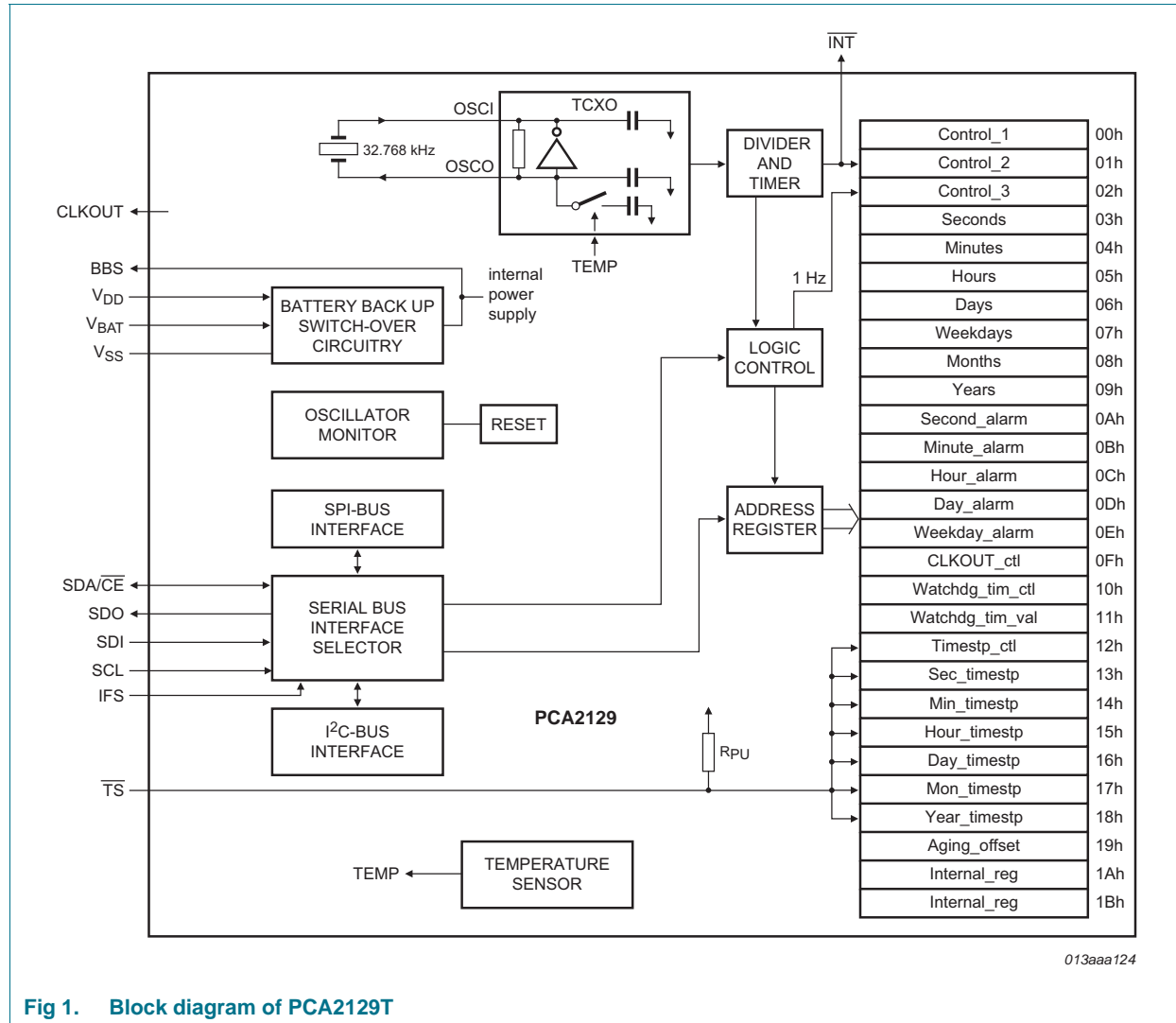
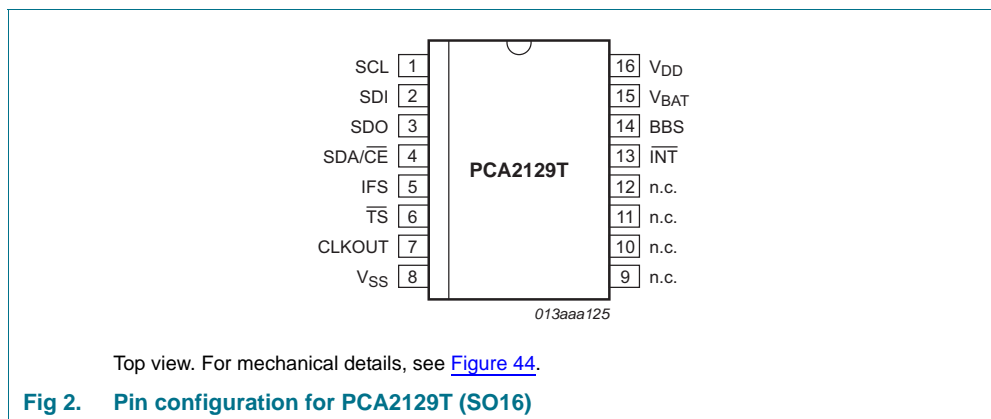

Fig 1. Block diagram of PCA2129T

7. Pinning information

7.1 Pinning



7.2 Pin description

Table 4. Pin description of PCA2129T

Symbol	Pin	Description
SCL	1	combined serial clock input for both I ² C-bus and SPI-bus; may float when SDA/CE inactive
SDI	2	serial data input for SPI-bus; may float when SDA/CE inactive
SDO	3	serial data output for SPI-bus, push-pull
SDA/CE	4	combined serial data input and output for the I ² C-bus and chip enable input (active LOW) for the SPI-bus
IFS	5	interface selector input connect to pin V _{SS} to select the SPI-bus connect to pin BBS to select the I ² C-bus
TS	6	timestamp input (active LOW) with 200 kΩ internal pull-up resistor (R _{PU})
CLKOUT	7	clock output (open-drain)
V _{SS}	8	ground supply voltage
n.c.	9 to 12	not connected; do not connect; do not use as feed through
INT	13	interrupt output (open-drain; active LOW)
BBS	14	output voltage (battery backed)
V _{BAT}	15	battery supply voltage (backup) connect to V _{SS} if battery switch over is not used
V _{DD}	16	supply voltage

8. Functional description

The PCA2129T is a Real Time Clock (RTC) and calendar with an on-chip Temperature Compensated Crystal (Xtal) Oscillator (TCXO) and a 32.768 kHz quartz crystal integrated into the same package (see [Section 8.3.2](#)).

Address and data are transferred by a selectable 400 kHz Fast-mode I²C-bus or a 3 line SPI-bus with separate data input and output (see [Section 9](#)). The maximum speed of the SPI-bus is 6.5 Mbit/s.

The PCA2129T has a backup battery input pin and backup battery switch-over circuit which monitors the main power supply. The backup battery switch-over circuit automatically switches to the backup battery when a power failure condition is detected (see [Section 8.5.1](#)). Accurate timekeeping is maintained even when the main power supply is interrupted.

A battery low detection circuit monitors the status of the battery (see [Section 8.5.3](#)). When the battery voltage drops below a certain threshold value, a flag is set to indicate that the battery must be replaced soon. This ensures the integrity of the data during periods of battery backup.

8.1 Register overview

The PCA2129T contains an auto-incrementing address register: the built-in address register will increment automatically after each read or write of a data byte up to the register 1Bh. After register 1Bh, the auto-incrementing will wrap around to address 00h (see [Figure 3](#)).

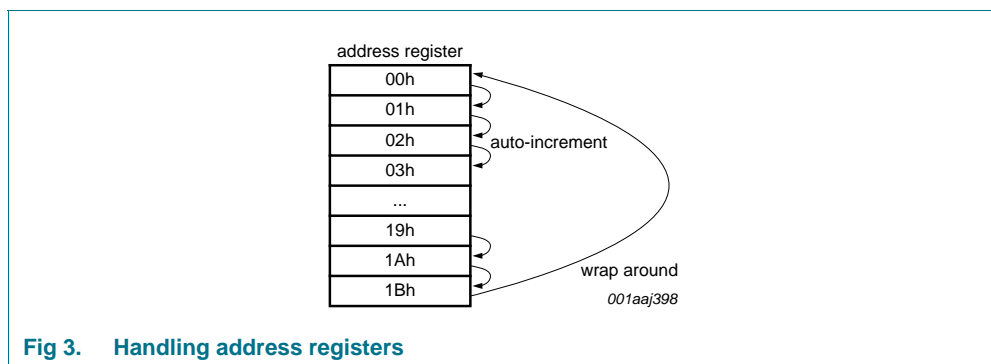

Fig 3. Handling address registers

- The first three registers (memory address 00h, 01h, and 02h) are used as control registers (see [Section 8.2](#)).
- The memory addresses 03h through to 09h are used as counters for the clock function (seconds up to years). The date is automatically adjusted for months with fewer than 31 days, including corrections for leap years. The clock can operate in 12-hour mode with an AM/PM indication or in 24-hour mode (see [Section 8.8](#)).
- The registers at addresses 0Ah through 0Eh define the alarm function. It can be selected that an interrupt is generated when an alarm event occurs (see [Section 8.9](#)).

- The register at address 0Fh defines the temperature measurement period and the clock out mode. The temperature measurement can be selected from every 4 minutes (default) down to every 30 seconds (see [Table 10](#)). CLKOUT frequencies of 32.768 kHz (default) down to 1 Hz for use as system clock, microcontroller clock, and so on, can be chosen (see [Table 11](#)).
- The registers at addresses 10h and 11h are used for the watchdog timer functions. The watchdog timer has four selectable source clocks allowing for timer periods from less than 1 ms to greater than 4 hours (see [Table 33](#)). An interrupt will be generated when the watchdog times out.
- The registers at addresses 12h to 18h are used for the timestamp function. When the trigger event happens, the actual time is saved in the timestamp registers (see [Section 8.11](#)).
- The register at address 19h is used for the correction of the crystal aging effect (see [Section 8.4.1](#)).
- The registers at addresses 1Ah and 1Bh are for internal use only.
- The registers Seconds, Minutes, Hours, Days, Months, and Years are all coded in Binary Coded Decimal (BCD) format to simplify application use. Other registers are either bit-wise or standard binary.

When one of the RTC registers is written or read, the content of all counters is temporarily frozen. This prevents a faulty writing or reading of the clock and calendar during a carry condition (see [Section 8.8.8](#)).

Table 5. Register overview

Bit positions labeled as - are not implemented and will return 0 when read. Bits labeled as T must always be written with logic 0. Bits labeled as X are undefined at power-on and unchanged by subsequent resets.

Address	Register name	Bit								Reset value	Reference
		7	6	5	4	3	2	1	0		
Control registers											
00h	Control_1	EXT_TEST	T	STOP	TSF1	POR_OVRD	12_24	MI	SI	0000 0000	Table 6 on page 9
01h	Control_2	MSF	WDTF	TSF2	AF	T	TSIE	AIE	T	0000 0000	Table 7 on page 10
02h	Control_3	PWRMNG[2:0]			BTSE	BF	BLF	BIE	BLIE	0000 0000	Table 8 on page 11
Time and date registers											
03h	Seconds	OSF	SECONDS (0 to 59)							1XXX XXXX	Table 16 on page 23
04h	Minutes	-	MINUTES (0 to 59)							- XXX XXXX	Table 18 on page 23
05h	Hours	-	-	AMPM	HOURS (1 to 12) in 12 h mode					- - XX XXXX	Table 19 on page 24
					HOURS (0 to 23) in 24 h mode					- - XX XXXX	
06h	Days	-	-	DAYS (1 to 31)					- - XX XXXX	Table 20 on page 24	
07h	Weekdays	-	-	-	-	-	WEEKDAYS (0 to 6)			- - - - XXX	Table 21 on page 24
08h	Months	-	-	-	MONTHS (1 to 12)				- - - X XXXX	Table 23 on page 25	
09h	Years	YEARS (0 to 99)							XXXX XXXX	Table 25 on page 25	
Alarm registers											
0Ah	Second_alarm	AE_S	SECOND_ALARM (0 to 59)							1XXX XXXX	Table 26 on page 27
0Bh	Minute_alarm	AE_M	MINUTE_ALARM (0 to 59)							1XXX XXXX	Table 27 on page 28
0Ch	Hour_alarm	AE_H	-	AMPM	HOUR_ALARM (1 to 12) in 12 h mode					1 - XX XXXX	Table 28 on page 28
					HOUR_ALARM (0 to 23) in 24 h mode					1 - XX XXXX	
0Dh	Day_alarm	AE_D	-	DAY_ALARM (1 to 31)					1 - XX XXXX	Table 29 on page 28	
0Eh	Weekday_alarm	AE_W	-	-	-	-	WEEKDAY_ALARM (0 to 6)			1 - - - XXX	Table 30 on page 29
CLKOUT control register											
0Fh	CLKOUT_ctl	TCR[1:0]	-	-	-	COF[2:0]		00 - - - 000		Table 9 on page 12	
Watchdog registers											
10h	Watchdg_tim_ctl	WD_CD	T	TI_TP	-	-	-	TF[1:0]	000 - - - 11		Table 31 on page 30
11h	Watchdg_tim_val	WATCHDG_TIM_VAL[7:0]							XXXX XXXX		Table 32 on page 30
Timestamp registers											
12h	Timestamp_ctl	TSM	TSOFF	-	1_O_16_TIMESTAMP[4:0]				00 - X XXXX		Table 38 on page 35

Table 5. Register overview ...continued

Bit positions labeled as - are not implemented and will return 0 when read. Bits labeled as T must always be written with logic 0. Bits labeled as X are undefined at power-on and unchanged by subsequent resets.

Address	Register name	Bit								Reset value	Reference	
		7	6	5	4	3	2	1	0			
13h	Sec_timestp	-	SECOND_TIMESTP (0 to 59)								- XXX XXXX	Table 39 on page 35
14h	Min_timestp	-	MINUTE_TIMESTP (0 to 59)								- XXX XXXX	Table 40 on page 35
15h	Hour_timestp	-	-	AMPM	HOUR_TIMESTP (1 to 12) in 12 h mode				-	- XX XXXX	Table 41 on page 36	
					HOUR_TIMESTP (0 to 23) in 24 h mode							
16h	Day_timestp	-	-	DAY_TIMESTP (1 to 31)						- - XX XXXX	Table 42 on page 36	
17h	Mon_timestp	-	-	-	MONTH_TIMESTP (1 to 12)				- - - X XXXX	Table 43 on page 36		
18h	Year_timestp	YEAR_TIMESTP (0 to 99)								XXXX XXXX	Table 44 on page 36	
Aging offset register												
19h	Aging_offset	-	-	-	-	AO[3:0]			- - - - 1000	Table 12 on page 14		
Internal registers												
1Ah	Internal_reg	-	-	-	-	-	-	-	-	- - - - - -	-	
1Bh	Internal_reg	-	-	-	-	-	-	-	-	- - - - - -	-	

All information provided in this document is subject to legal disclaimers.

8.2 Control registers

The first 3 registers of the PCA2129T, with the addresses 00h, 01h, and 02h, are used as control registers.

8.2.1 Register Control_1

Table 6. Control_1 - control and status register 1 (address 00h) bit description

Bit	Symbol	Value	Description	Reference
7	EXT_TEST	0	[1] normal mode	Section 8.13
		1	external clock test mode	
6	T	0	[2] unused	-
5	STOP	0	[1] RTC source clock runs	Section 8.14
		1	RTC clock is stopped; RTC divider chain flip-flops are asynchronously set logic 0; CLKOUT at 32.768 kHz, 16.384 kHz, or 8.192 kHz is still available	
4	TSF1	0	[1] no timestamp interrupt generated	Section 8.11.1
		1	flag set when \overline{TS} input is driven to an intermediate level between power supply and ground; flag must be cleared to clear interrupt	
3	POR_OVRD	0	[1] Power-On Reset Override (PORO) facility disabled; set logic 0 for normal operation	Section 8.7.2
		1	PORO enabled	
2	12_24	0	[1] 24 hour mode selected	Table 19
		1	12 hour mode selected	
1	MI	0	[1] minute interrupt disabled	Section 8.12.1
		1	minute interrupt enabled	
0	SI	0	[1] second interrupt disabled	
		1	second interrupt enabled	

[1] Default value.

[2] When writing to the register this bit always has to be set logic 0.

8.2.2 Register Control_2

Table 7. Control_2 - control and status register 2 (address 01h) bit description

Bit	Symbol	Value	Description	Reference
7	MSF	0	[1] no minute or second interrupt generated	Section 8.12
		1	flag set when minute or second interrupt generated; flag must be cleared to clear interrupt	
6	WDTF	0	[1] no watchdog timer interrupt or reset generated	Section 8.12.3
		1	flag set when watchdog timer interrupt or reset generated; flag cannot be cleared by command (read-only)	
5	TSF2	0	[1] no timestamp interrupt generated	Section 8.11.1
		1	flag set when \overline{TS} input is driven to ground; flag must be cleared to clear interrupt	
4	AF	0	[1] no alarm interrupt generated	Section 8.9.6
		1	flag set when alarm triggered; flag must be cleared to clear interrupt	
3	T	0	[2] unused	-
2	TSIE	0	[1] no interrupt generated from timestamp flag	Section 8.12.5
		1	interrupt generated when timestamp flag set	
1	AIE	0	[1] no interrupt generated from the alarm flag	Section 8.12.4
		1	interrupt generated when alarm flag set	
0	T	0	[2] unused	-

[1] Default value.

[2] When writing to the register this bit always has to be set logic 0.

8.2.3 Register Control_3

Table 8. Control_3 - control and status register 3 (address 02h) bit description

Bit	Symbol	Value	Description	Reference
7 to 5	PWRMNG[2:0]	[1]	control of the battery switch-over, battery low detection, and extra power fail detection functions	Section 8.5
4	BTSE	0	[2] no timestamp when battery switch-over occurs	Section 8.11.4
		1	time-stamped when battery switch-over occurs	
3	BF	0	[2] no battery switch-over interrupt generated	Section 8.5.1 and Section 8.11.4
		1	flag set when battery switch-over occurs; flag must be cleared to clear interrupt	
2	BLF	0	[2] battery status ok; no battery low interrupt generated	Section 8.5.3
		1	battery status low; flag cannot be cleared by command	
1	BIE	0	[2] no interrupt generated from the battery flag (BF)	Section 8.12.6
		1	interrupt generated when BF is set	
0	BLIE	0	[2] no interrupt generated from battery low flag (BLF)	Section 8.12.7
		1	interrupt generated when BLF is set	

[1] Values see [Table 14](#).

[2] Default value.

8.3 Register CLKOUT_ctl

Table 9. CLKOUT_ctl - CLKOUT control register (address 0Fh) bit description

Bit	Symbol	Value	Description
7 to 6	TCR[1:0]	see Table 10	temperature measurement period
5 to 3	-	-	unused
2 to 0	COF[2:0]	see Table 11	CLKOUT frequency selection

8.3.1 Temperature compensated crystal oscillator

The frequency of tuning fork quartz crystal oscillators is temperature-dependent. In the PCA2129T, the frequency deviation caused by temperature variation is corrected by adjusting the load capacitance of the crystal oscillator.

The load capacitance is changed by switching between two load capacitance values using a modulation signal with a programmable duty cycle. In order to compensate the spread of the quartz parameters every chip is factory calibrated.

The frequency accuracy can be evaluated by measuring the frequency of the square wave signal available at the output pin CLKOUT. However, the selection of $f_{\text{CLKOUT}} = 32.768$ kHz (default value) leads to inaccurate measurements. Accurate frequency measurement occurs when $f_{\text{CLKOUT}} = 16.384$ kHz or lower is selected (see [Table 11](#)).

8.3.1.1 Temperature measurement

The PCA2129T has a temperature sensor circuit used to perform the temperature compensation of the frequency. The temperature is measured immediately after power-on and then periodically with a period set by the temperature conversion rate TCR[1:0] in the register CLKOUT_ctl.

Table 10. Temperature measurement period

TCR[1:0]	Temperature measurement period
00	[1] 4 min
01	2 min
10	1 min
11	30 seconds

[1] Default value.

8.3.2 Clock output

A programmable square wave is available at pin CLKOUT. Operation is controlled by the COF[2:0] control bits in register CLKOUT_ctl. Frequencies of 32.768 kHz (default) down to 1 Hz can be generated for use as system clock, microcontroller clock, charge pump input, or for calibrating the oscillator.

CLKOUT is an open-drain output and enabled at power-on. When disabled, the output is high-impedance.

The duty cycle of the selected clock is not controlled, however, due to the nature of the clock generation all but the 32.768 kHz frequencies will be 50 : 50.

Table 11. CLKOUT frequency selection

COF[2:0]	CLKOUT frequency (Hz)	Typical duty cycle ^[1]
000 ^{[2][3]}	32768	60 : 40 to 40 : 60
001	16384	50 : 50
010	8192	50 : 50
011	4096	50 : 50
100	2048	50 : 50
101	1024	50 : 50
110	1	50 : 50
111	CLKOUT = high-Z	-

[1] Duty cycle definition: % HIGH-level time : % LOW-level time.

[2] Default value.

[3] The specified accuracy of the RTC can be only achieved with CLKOUT frequencies not equal to 32.768 kHz or if CLKOUT is disabled.

8.4 Register Aging_offset

Table 12. Aging_offset - crystal aging offset register (address 19h) bit description

Bit	Symbol	Value	Description
7 to 4	-	-	unused
3 to 0	AO[3:0]	see Table 13	aging offset value

8.4.1 Crystal aging correction

The PCA2129T has an offset register Aging_offset to correct the crystal aging effects².

The accuracy of the frequency of a quartz crystal depends on its aging. The aging offset adds an adjustment, positive or negative, in the temperature compensation circuit which allows correcting the aging effect.

At 25 °C, the aging offset bits allow a frequency correction of typically 1 ppm per AO[3:0] value, from -7 ppm to +8 ppm.

Table 13. Frequency correction at 25 °C, typical

AO[3:0]		ppm
Decimal	Binary	
0	0000	+8
1	0001	+7
2	0010	+6
3	0011	+5
4	0100	+4
5	0101	+3
6	0110	+2
7	0111	+1
8	1000	0 ^[1]
9	1001	-1
10	1010	-2
11	1011	-3
12	1100	-4
13	1101	-5
14	1110	-6
15	1111	-7

[1] Default value.

2. For further information, refer to the application note [Ref. 3 "AN11120"](#).

8.5 Power management functions

The PCA2129T has two power supply pins and one power output pin:

- V_{DD} - the main power supply input pin
- V_{BAT} - the battery backup input pin
- BBS - battery backed output voltage pin (equal to the internal power supply)

The PCA2129T has two power management functions implemented:

- Battery switch-over function
- Battery low detection function

The power management functions are controlled by the control bits PWRMNG[2:0] in register Control_3:

Table 14. Power management control bit description

PWRMNG[2:0]	Function
000	[1] battery switch-over function is enabled in standard mode; battery low detection function is enabled
001	battery switch-over function is enabled in standard mode; battery low detection function is disabled
010	battery switch-over function is enabled in standard mode; battery low detection function is disabled
011	battery switch-over function is enabled in direct switching mode; battery low detection function is enabled
100	battery switch-over function is enabled in direct switching mode; battery low detection function is disabled
101	battery switch-over function is enabled in direct switching mode; battery low detection function is disabled
111	[2] battery switch-over function is disabled, only one power supply (V_{DD}); battery low detection function is disabled

[1] Default value.

[2] When the battery switch-over function is disabled, the PCA2129T works only with the power supply V_{DD} . V_{BAT} must be put to ground and the battery low detection function is disabled.

8.5.1 Battery switch-over function

The PCA2129T has a backup battery switch-over circuit which monitors the main power supply V_{DD} . When a power failure condition is detected, it automatically switches to the backup battery.

One of two operation modes can be selected:

- **Standard mode:** the power failure condition happens when:
 $V_{DD} < V_{BAT}$ AND $V_{DD} < V_{th(sw)bat}$
 $V_{th(sw)bat}$ is the battery switch threshold voltage. Typical value is 2.5 V. The battery switch-over in standard mode works only for $V_{DD} > 2.5$ V.
- **Direct switching mode:** the power failure condition happens when $V_{DD} < V_{BAT}$.
 Direct switching from V_{DD} to V_{BAT} without requiring V_{DD} to drop below $V_{th(sw)bat}$

When a power failure condition occurs and the power supply switches to the battery, the following sequence occurs:

1. The battery switch flag BF (register Control_3) is set logic 1.
2. An interrupt is generated if the control bit BIE (register Control_3) is enabled (see [Section 8.12.6](#)).
3. If the control bit BTSE (register Control_3) is logic 1, the timestamp registers store the time and date when the battery switch occurred (see [Section 8.11.4](#)).
4. The battery switch flag BF is cleared by command; it must be cleared to clear the interrupt.

The interface is disabled in battery backup operation:

- Interface inputs are not recognized, preventing extraneous data being written to the device
- Interface outputs are high-impedance

8.5.1.1 Standard mode

If $V_{DD} > V_{BAT}$ OR $V_{DD} > V_{th(sw)bat}$, the internal power supply is V_{DD} .

If $V_{DD} < V_{BAT}$ AND $V_{DD} < V_{th(sw)bat}$, the internal power supply is V_{BAT} .

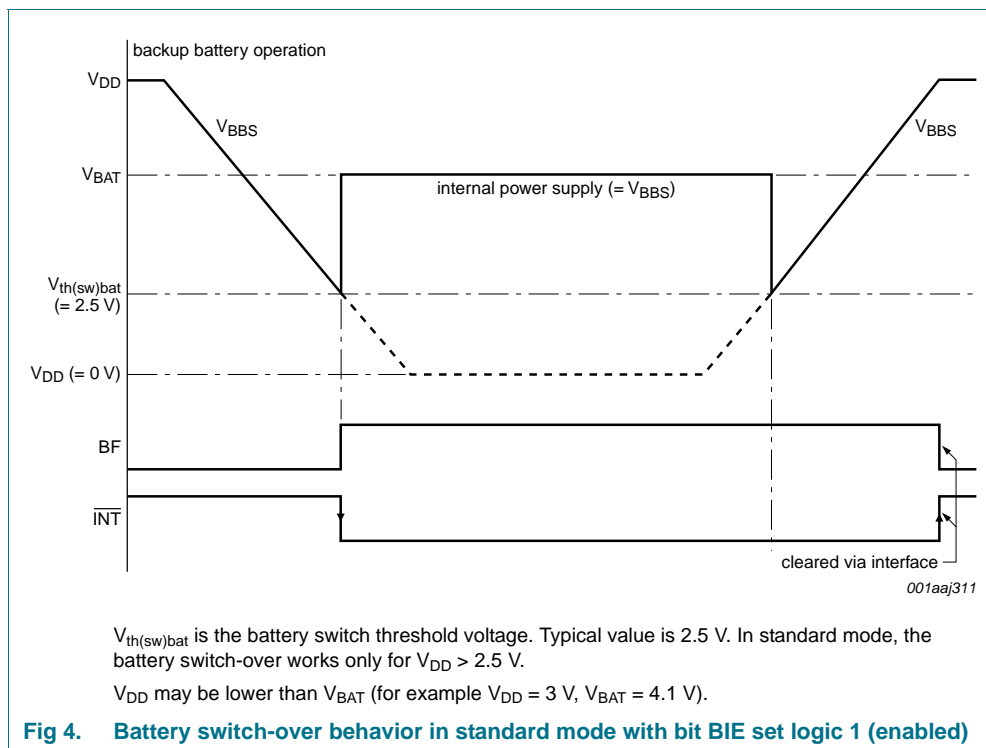

8.5.1.2 Direct switching mode

If $V_{DD} > V_{BAT}$ the internal power supply is V_{DD} .

If $V_{DD} < V_{BAT}$ the internal power supply is V_{BAT} .

The direct switching mode is useful in systems where V_{DD} is higher than V_{BAT} at all times. This mode is not recommended if the V_{DD} and V_{BAT} values are similar (for example, $V_{DD} = 3.3\text{ V}$, $V_{BAT} \geq 3.0\text{ V}$). In direct switching mode, the power consumption is reduced compared to the standard mode because the monitoring of V_{DD} and $V_{th(sw)bat}$ is not performed.

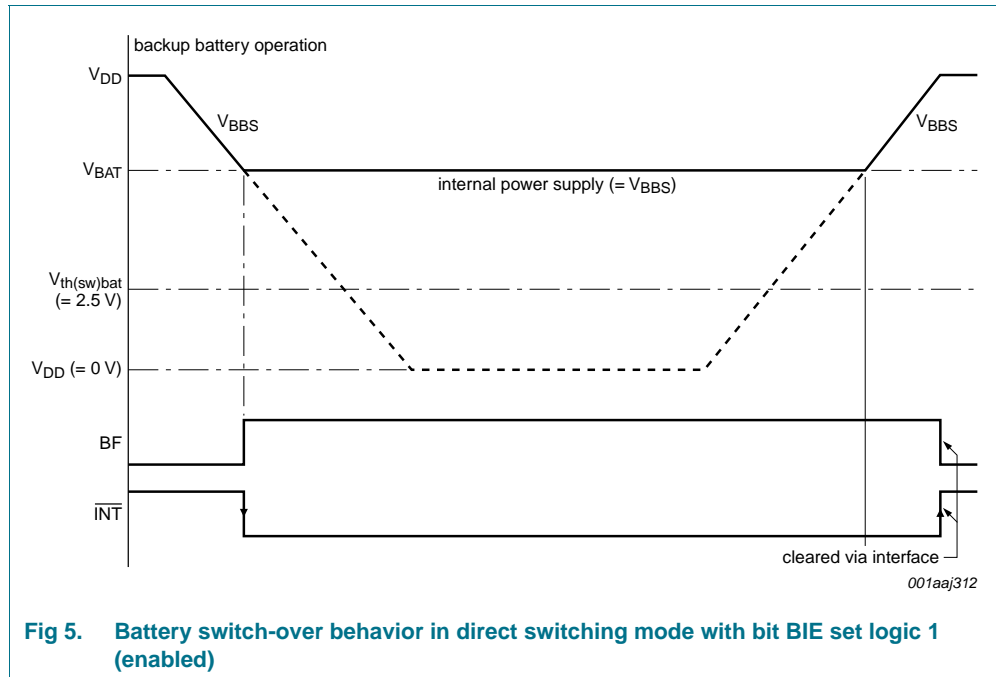

8.5.1.3 Battery switch-over disabled: only one power supply (V_{DD})

When the battery switch-over function is disabled:

- The power supply is applied on the V_{DD} pin
- The V_{BAT} pin must be connected to ground
- The internal power supply, available at the output pin BBS, is equal to V_{DD}
- The battery flag (BF) is always logic 0

8.5.1.4 Battery switch-over architecture

The architecture of the battery switch-over circuit is shown in [Figure 6](#).

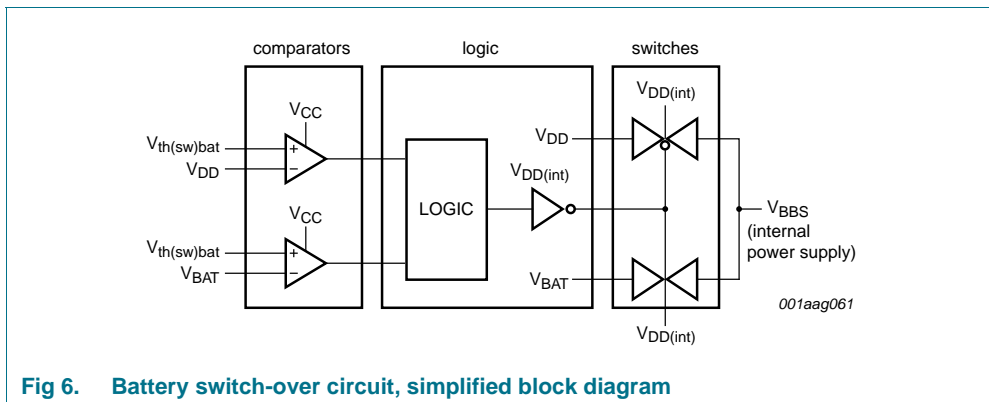

Fig 6. Battery switch-over circuit, simplified block diagram

The internal power supply (available on pin BBS) is equal to V_{DD} or V_{BAT} . It has to be assured that there are decoupling capacitors on the pins V_{DD} , V_{BAT} , and BBS.

8.5.2 Battery backup supply

The V_{BBS} voltage on the output pin BBS is equal to the internal power supply, depending on the selected battery switch-over function mode:

Table 15. Output pin BBS

Battery switch-over function mode	Conditions	V_{BBS} equals
standard	$V_{DD} > V_{BAT}$ OR $V_{DD} > V_{th(sw)bat}$	V_{DD}
	$V_{DD} < V_{BAT}$ AND $V_{DD} < V_{th(sw)bat}$	V_{BAT}
direct switching	$V_{DD} > V_{BAT}$	V_{DD}
	$V_{DD} < V_{BAT}$	V_{BAT}
disabled	only V_{DD} available, V_{BAT} must be put to ground	V_{DD}

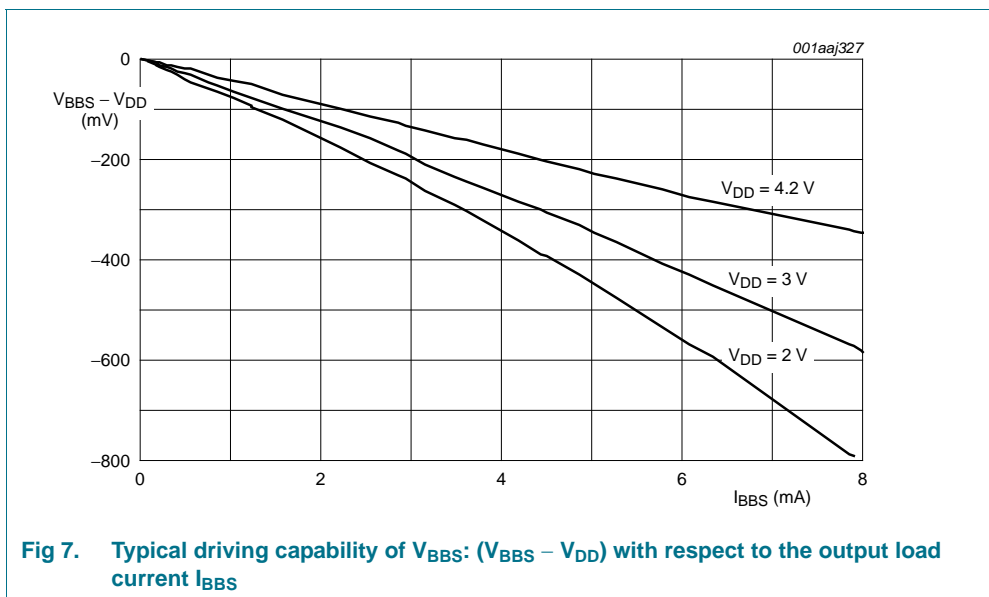

Fig 7. Typical driving capability of V_{BBS} : ($V_{BBS} - V_{DD}$) with respect to the output load current I_{BBS}

The output pin BBS can be used as a supply for external devices with battery backup needs, such as SRAM (see [Ref. 3 "AN11120"](#)). For this case, [Figure 7](#) shows the typical driving capability when V_{BBS} is driven from V_{DD} .

8.5.3 Battery low detection function

The PCA2129T has a battery low detection circuit which monitors the status of the battery V_{BAT} .

When V_{BAT} drops below the threshold value $V_{th(bat)low}$ (typically 2.5 V), the BLF flag (register Control_3) is set to indicate that the battery is low and that it must be replaced. Monitoring of the battery voltage also occurs during battery operation.

An unreliable battery cannot prevent that the supply voltage drops below V_{low} (typical 1.2 V) and with that the data integrity gets lost.

When V_{BAT} drops below the threshold value $V_{th(bat)low}$, the following sequence occurs (see [Figure 8](#)):

1. The battery low flag BLF is set logic 1.
2. An interrupt is generated if the control bit BLIE (register Control_3) is enabled (see [Section 8.12.7](#)).
3. The flag BLF remains logic 1 until the battery is replaced. BLF cannot be cleared by command. It is cleared automatically by the battery low detection circuit when the battery is replaced.

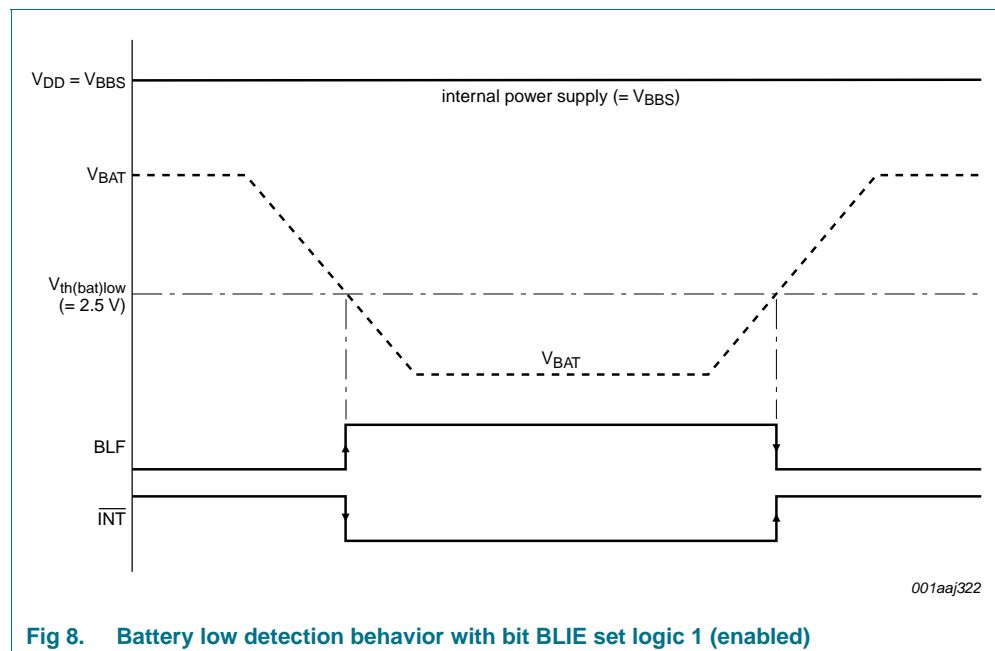

Fig 8. Battery low detection behavior with bit BLIE set logic 1 (enabled)

8.6 Oscillator stop detection function

The PCA2129T has an on-chip oscillator detection circuit which monitors the status of the oscillation: whenever the oscillation stops, a reset occurs and the oscillator stop flag OSF (in register Seconds) is set logic 1.

- **Power-on:**
 - a. The oscillator is not running, the chip is in reset (OSF is logic 1).
 - b. When the oscillator starts running and is stable after power-on, the chip exits from reset.
 - c. The flag OSF is still logic 1 and can be cleared (OSF set logic 0) by command.
- **Power supply failure:**
 - a. When the power supply of the chip (V_{BBS} , see [Section 8.5.2](#)) drops below a certain value (V_{low}), typically 1.2 V, the oscillator stops running and a reset occurs.
 - b. When the power supply returns to normal operation, the oscillator starts running again, the chip exits from reset.
 - c. The flag OSF is still logic 1 and can be cleared (OSF set logic 0) by command.

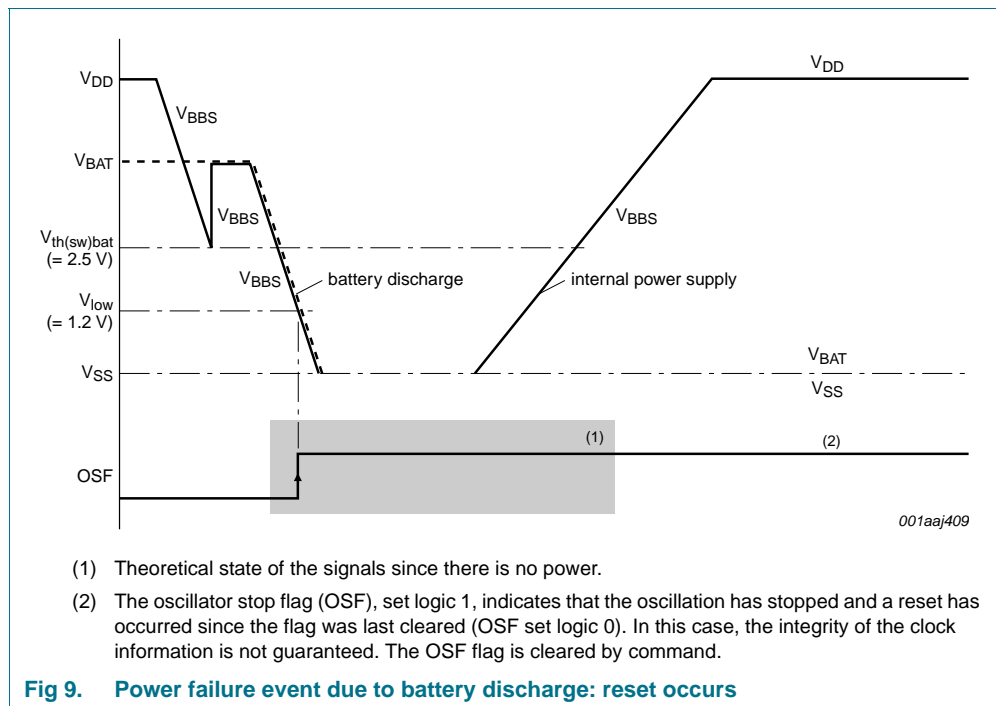

Fig 9. Power failure event due to battery discharge: reset occurs

8.7 Reset function

The PCA2129T has a Power-On Reset (POR) and a Power-On Reset Override (PORO) function implemented.

8.7.1 Power-On Reset (POR)

The POR is active whenever the oscillator is stopped. The oscillator is also considered to be stopped during the time between power-on and stable crystal resonance (see [Figure 10](#)). This time may be in the range of 200 ms to 2 s depending on temperature and supply voltage. Whenever an internal reset occurs, the oscillator stop flag is set (OSF set logic 1).

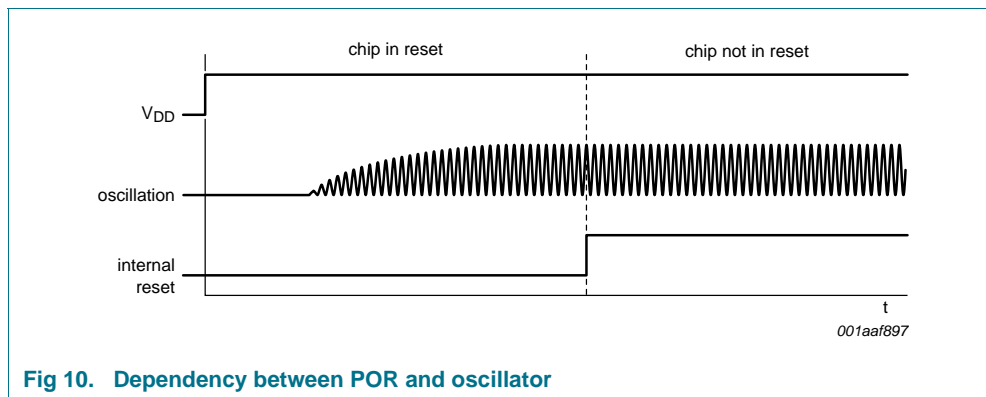

Fig 10. Dependency between POR and oscillator

After POR, the following mode is entered:

- 32.768 kHz CLKOUT active
- Power-On Reset Override (PORO) available to be set
- 24 hour mode is selected
- Battery switch-over is enabled
- Battery low detection is enabled

The register values after power-on are shown in [Table 5](#).

8.7.2 Power-On Reset Override (PORO)

The POR duration is directly related to the crystal oscillator start-up time. Due to the long start-up times experienced by these types of circuits, a mechanism has been built in to disable the POR and therefore speed up the on-board test of the device.

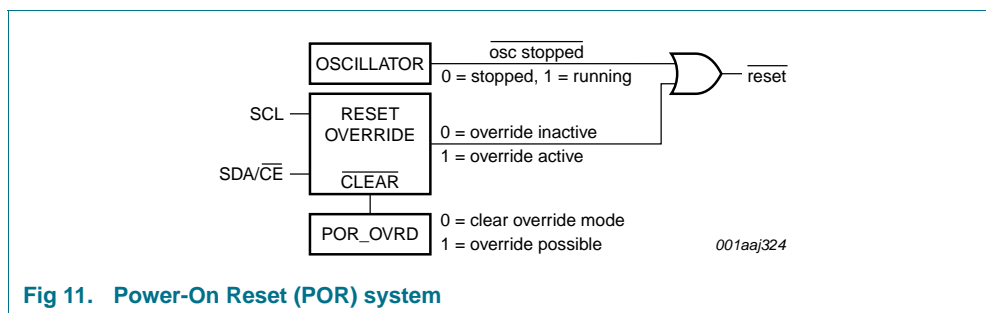

Fig 11. Power-On Reset (POR) system

The setting of the PORO mode requires that POR_OVRD in register Control_1 is set logic 1 and that the signals at the interface pins SDA/ $\overline{\text{CE}}$ and SCL are toggled as illustrated in [Figure 12](#). All timings shown are required minimum.

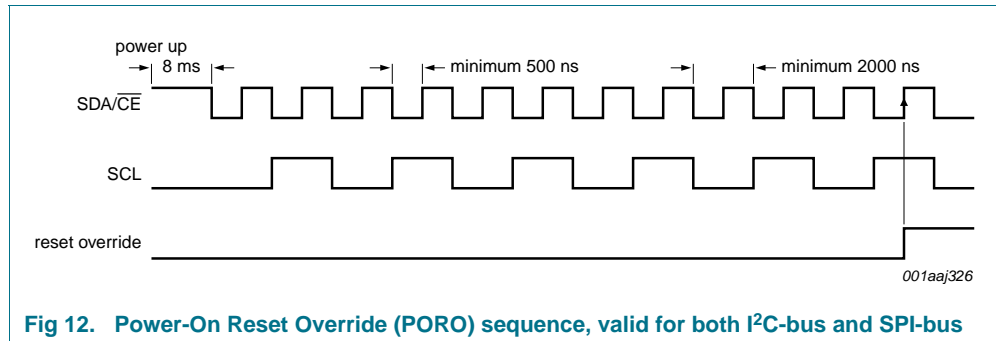

Fig 12. Power-On Reset Override (PORO) sequence, valid for both I²C-bus and SPI-bus

Once the override mode is entered, the device is immediately released from the reset state and the set-up operation can commence.

The PORO mode is cleared by writing logic 0 to POR_OVRD. POR_OVRD must be logic 1 before a re-entry into the override mode is possible. Setting POR_OVRD logic 0 during normal operation has no effect except to prevent accidental entry into the PORO mode.

8.8 Time and date function

Most of these registers are coded in the Binary Coded Decimal (BCD) format.

8.8.1 Register Seconds

Table 16. Seconds - seconds and clock integrity register (address 03h) bit description

Bit	Symbol	Value	Place value	Description
7	OSF	0	-	clock integrity is guaranteed
		1 ^[1]	-	clock integrity is not guaranteed: oscillator has stopped and chip reset has occurred since flag was last cleared
6 to 4	SECONDS	0 to 5	ten's place	actual seconds coded in BCD format
3 to 0		0 to 9	unit place	

[1] Start-up value.

Table 17. Seconds coded in BCD format

Seconds value in decimal	Upper-digit (ten's place)			Digit (unit place)			
	Bit 6	Bit 5	Bit 4	Bit 3	Bit 2	Bit 1	Bit 0
00	0	0	0	0	0	0	0
01	0	0	0	0	0	0	1
02	0	0	0	0	0	1	0
:	:	:	:	:	:	:	:
09	0	0	0	1	0	0	1
10	0	0	1	0	0	0	0
:	:	:	:	:	:	:	:
58	1	0	1	1	0	0	0
59	1	0	1	1	0	0	1

8.8.2 Register Minutes

Table 18. Minutes - minutes register (address 04h) bit description

Bit	Symbol	Value	Place value	Description
7	-	-	-	unused
6 to 4	MINUTES	0 to 5	ten's place	actual minutes coded in BCD format
3 to 0		0 to 9	unit place	

8.8.3 Register Hours

Table 19. Hours - hours register (address 05h) bit description

Bit	Symbol	Value	Place value	Description
7 to 6	-	-	-	unused
12 hour mode^[1]				
5	AMPM	0	-	indicates AM
		1	-	indicates PM
4	HOURS	0 to 1	ten's place	actual hours coded in BCD format when in 12 hour mode
3 to 0		0 to 9	unit place	
24 hour mode^[1]				
5 to 4	HOURS	0 to 2	ten's place	actual hours coded in BCD format when in 24 hour mode
3 to 0		0 to 9	unit place	

[1] Hour mode is set by the bit 12_24 in register Control_1.

8.8.4 Register Days

Table 20. Days - days register (address 06h) bit description

Bit	Symbol	Value	Place value	Description
7 to 6	-	-	-	unused
5 to 4	DAYS ^[1]	0 to 3	ten's place	actual day coded in BCD format
3 to 0		0 to 9	unit place	

[1] If the year counter contains a value which is exactly divisible by 4, including the year 00, the RTC compensates for leap years by adding a 29th day to February.

8.8.5 Register Weekdays

Table 21. Weekdays - weekdays register (address 07h) bit description

Bit	Symbol	Value	Description
7 to 3	-	-	unused
2 to 0	WEEKDAYS	0 to 6	actual weekday value, see Table 22

Although the association of the weekdays counter to the actual weekday is arbitrary, the PCA2129T will assume that Sunday is 000 and Monday is 001 for the purposes of determining the increment for calendar weeks.

Table 22. Weekday assignments

Day ^[1]	Bit		
	2	1	0
Sunday	0	0	0
Monday	0	0	1
Tuesday	0	1	0
Wednesday	0	1	1
Thursday	1	0	0
Friday	1	0	1
Saturday	1	1	0

[1] Definition may be reassigned by the user.

8.8.6 Register Months

Table 23. Months - months register (address 08h) bit description

Bit	Symbol	Value	Place value	Description
7 to 5	-	-	-	unused
4	MONTHS	0 to 1	ten's place	actual month coded in BCD format, see Table 24
3 to 0		0 to 9	unit place	

Table 24. Month assignments in BCD format

Month	Upper-digit (ten's place)	Digit (unit place)			
	Bit 4	Bit 3	Bit 2	Bit 1	Bit 0
January	0	0	0	0	1
February	0	0	0	1	0
March	0	0	0	1	1
April	0	0	1	0	0
May	0	0	1	0	1
June	0	0	1	1	0
July	0	0	1	1	1
August	0	1	0	0	0
September	0	1	0	0	1
October	1	0	0	0	0
November	1	0	0	0	1
December	1	0	0	1	0

8.8.7 Register Years

Table 25. Years - years register (address 09h) bit description

Bit	Symbol	Value	Place value	Description
7 to 4	YEARS	0 to 9	ten's place	actual year coded in BCD format
3 to 0		0 to 9	unit place	

8.8.8 Setting and reading the time

[Figure 13](#) shows the data flow and data dependencies starting from the 1 Hz clock tick.

During read/write operations, the time counting circuits (memory locations 03h through 09h) are blocked.

This prevents

- Faulty reading of the clock and calendar during a carry condition
- Incrementing the time registers during the read cycle

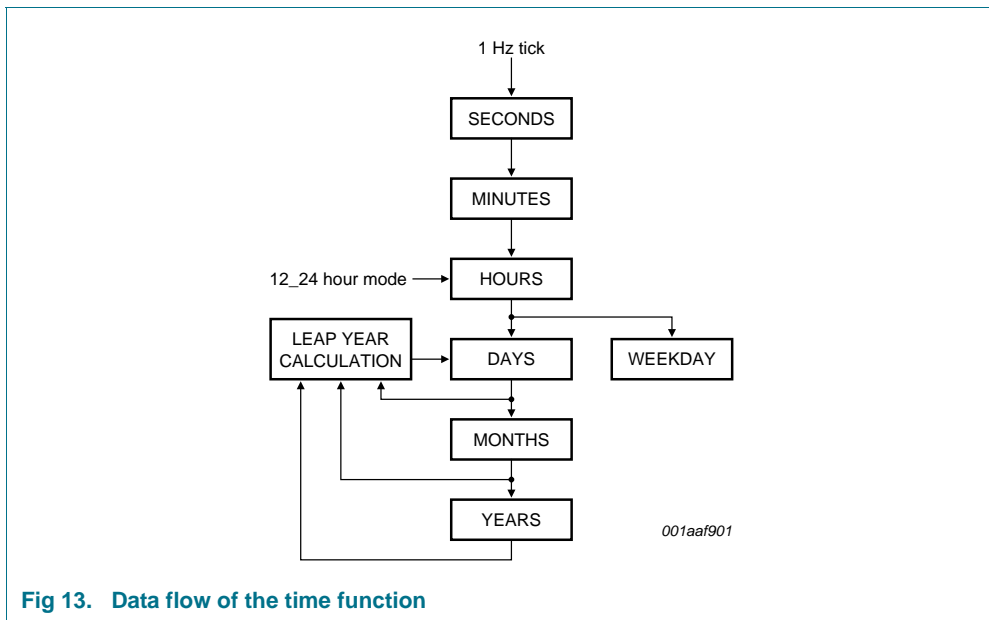

Fig 13. Data flow of the time function

After this read/write access is completed, the time circuit is released again. Any pending request to increment the time counters that occurred during the read/write access is serviced. A maximum of 1 request can be stored; therefore, all accesses must be completed within 1 second (see Figure 14).

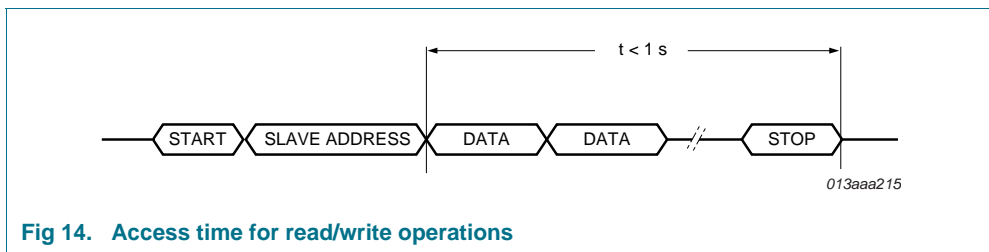

Fig 14. Access time for read/write operations

As a consequence of this method, it is very important to make a read or write access in one go, that is, setting or reading seconds through to years should be made in one single access. Failing to comply with this method could result in the time becoming corrupted.

As an example, if the time (seconds through to hours) is set in one access and then in a second access the date is set, it is possible that the time may increment between the two accesses. A similar problem exists when reading. A roll-over may occur between reads thus giving the minutes from one moment and the hours from the next. Therefore it is advised to read all time and date registers in one access.

8.9 Alarm function

When one or more of the alarm bit fields are loaded with a valid second, minute, hour, day, or weekday and its corresponding alarm enable bit (AE_x) is logic 0, then that information is compared with the actual second, minute, hour, day, and weekday (see [Figure 15](#)).

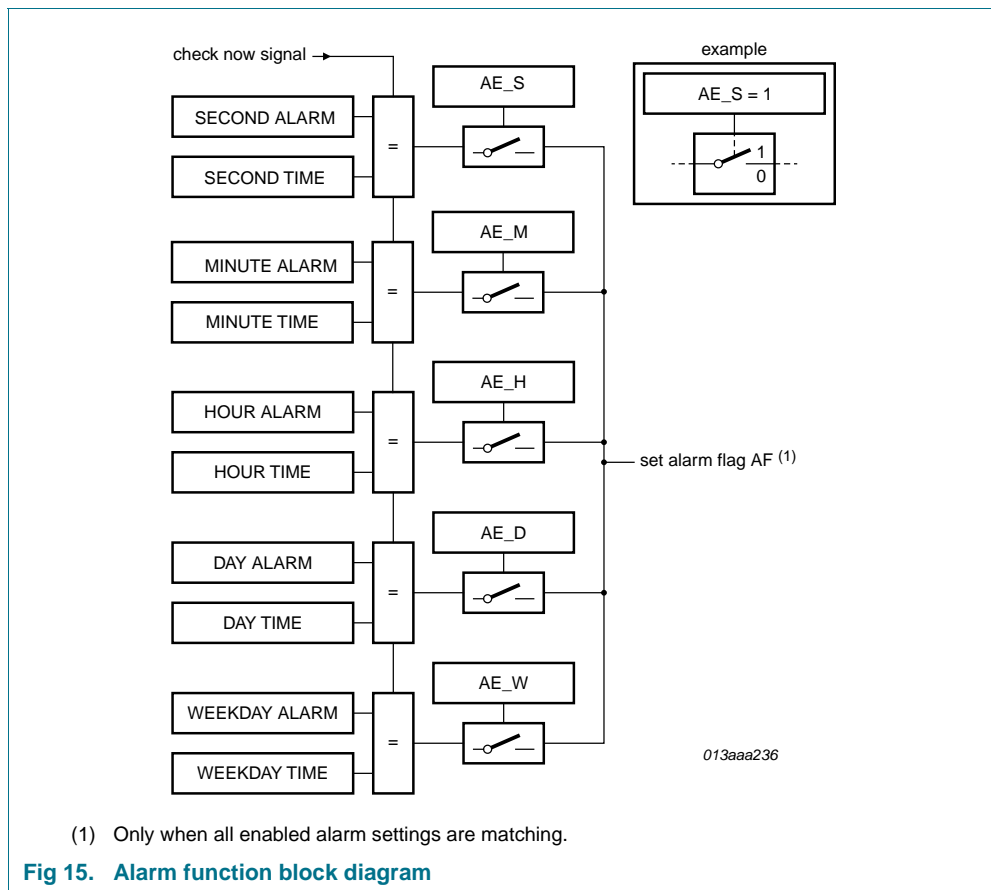

The generation of interrupts from the alarm function is described in [Section 8.12.4](#).

8.9.1 Register Second_alarm

Table 26. Second_alarm - second alarm register (address 0Ah) bit description

Bit	Symbol	Value	Place value	Description
7	AE_S	0	-	second alarm is enabled
		1 ^[1]	-	second alarm is disabled
6 to 4	SECOND_ALARM	0 to 5	ten's place	second alarm information coded in BCD format
3 to 0		0 to 9	unit place	

[1] Default value.

8.9.2 Register Minute_alarm

Table 27. Minute_alarm - minute alarm register (address 0Bh) bit description

Bit	Symbol	Value	Place value	Description
7	AE_M	0	-	minute alarm is enabled
		1 ^[1]	-	minute alarm is disabled
6 to 4	MINUTE_ALARM	0 to 5	ten's place	minute alarm information coded in BCD format
3 to 0		0 to 9	unit place	

[1] Default value.

8.9.3 Register Hour_alarm

Table 28. Hour_alarm - hour alarm register (address 0Ch) bit description

Bit	Symbol	Value	Place value	Description
7	AE_H	0	-	hour alarm is enabled
		1 ^[1]	-	hour alarm is disabled
6	-	-	-	unused
12 hour mode^[2]				
5	AMPM	0	-	indicates AM
		1	-	indicates PM
4	HOUR_ALARM	0 to 1	ten's place	hour alarm information coded in BCD format when in 12 hour mode
3 to 0		0 to 9	unit place	
24 hour mode^[2]				
5 to 4	HOUR_ALARM	0 to 2	ten's place	hour alarm information coded in BCD format when in 24 hour mode
3 to 0		0 to 9	unit place	

[1] Default value.

[2] Hour mode is set by the bit 12_24 in register Control_1.

8.9.4 Register Day_alarm

Table 29. Day_alarm - day alarm register (address 0Dh) bit description

Bit	Symbol	Value	Place value	Description
7	AE_D	0	-	day alarm is enabled
		1 ^[1]	-	day alarm is disabled
6	-	-	-	unused
5 to 4	DAY_ALARM	0 to 3	ten's place	day alarm information coded in BCD format
3 to 0		0 to 9	unit place	

[1] Default value.

8.9.5 Register Weekday_alarm

Table 30. Weekday_alarm - weekday alarm register (address 0Eh) bit description

Bit	Symbol	Value	Description
7	AE_W	0	weekday alarm is enabled
		1 ^[1]	weekday alarm is disabled
6 to 3	-	-	unused
2 to 0	WEEKDAY_ALARM	0 to 6	weekday alarm information

[1] Default value.

8.9.6 Alarm flag

When all enabled comparisons first match, the alarm flag AF (register Control_2) is set. AF will remain set until cleared by command. Once AF has been cleared, it will only be set again when the time increments to match the alarm condition once more. For clearing the flags. see [Section 8.10.5](#)

Alarm registers which have their alarm enable bit AE_x at logic 1 are ignored.

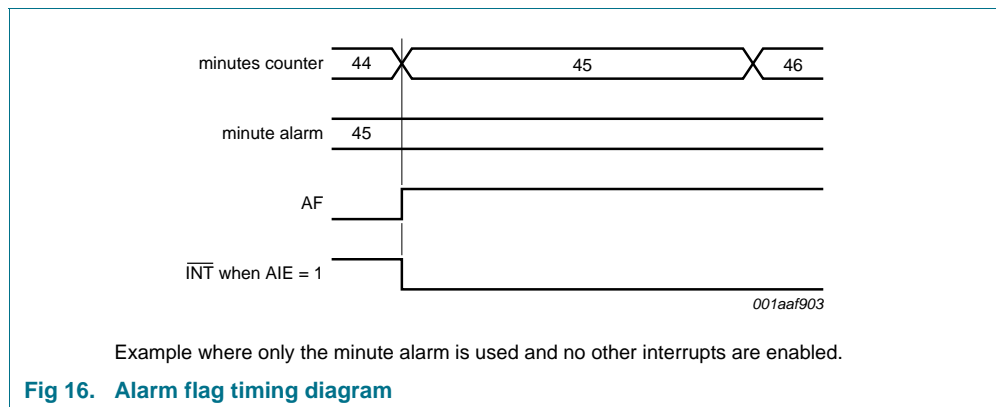

8.10 Timer functions

The PCA2129T has a watchdog timer function. The timer can be switched on and off by using the control bit WD_CD in the register Watchdg_tim_ctl.

The watchdog timer has four selectable source clocks. It can, for example, be used to detect a microcontroller with interrupt and reset capability which is out of control (see [Section 8.10.3](#))

To control the timer function and timer output, the registers Control_2, Watchdg_tim_ctl, and Watchdg_tim_val are used.

8.10.1 Register Watchdg_tim_ctl

Table 31. Watchdg_tim_ctl - watchdog timer control register (address 10h) bit description

Bit	Symbol	Value	Description
7	WD_CD	0 ^[1]	watchdog timer disabled
		1	watchdog timer enabled; the interrupt pin $\overline{\text{INT}}$ is activated when timed out
6	T	0 ^[2]	unused
5	TI_TP	0 ^[1]	the interrupt pin $\overline{\text{INT}}$ is configured to generate a permanent active signal when MSF (register Control_2) is set
		1	the interrupt pin $\overline{\text{INT}}$ is configured to generate a pulsed signal when MSF flag is set (see Figure 19)
4 to 2	-	-	unused
1 to 0	TF[1:0]	-	timer source clock for watchdog timer
		00	4.096 kHz
		01	64 Hz
		10	1 Hz
		11 ^[1]	$\frac{1}{60}$ Hz

[1] Default value.

[2] When writing to the register this bit always has to be set logic 0.

8.10.2 Register Watchdg_tim_val

Table 32. Watchdg_tim_val - watchdog timer value register (address 11h) bit description

Bit	Symbol	Value	Description
7 to 0	WATCHDG_TIM_VAL[7:0]	00 to FF	timer period in seconds: $\text{TimerPeriod} = \frac{n}{\text{SourceClockFrequency}}$ where n is the timer value

Table 33. Programmable watchdog timer

TF[1:0]	Timer source clock frequency	Units	Minimum timer period (n = 1)	Units	Maximum timer period (n = 255)	Units
00	4.096	kHz	244	μs	62.256	ms
01	64	Hz	15.625	ms	3.984	s
10	1	Hz	1	s	255	s
11	$\frac{1}{60}$	Hz	60	s	15300	s

8.10.3 Watchdog timer function

The watchdog timer function is enabled or disabled by the WD_CD bit of the register Watchdog_tim_ctl (see [Table 31](#)).

The two bits TF[1:0] in register Watchdog_tim_ctl determine one of the four source clock frequencies for the watchdog timer: 4.096 kHz, 64 Hz, 1 Hz, or $\frac{1}{60}$ Hz (see [Table 33](#)).

When the watchdog timer function is enabled, the 8-bit timer in register Watchdog_tim_val determines the watchdog timer period (see [Table 33](#)).

The watchdog timer counts down from the software programmed 8-bit binary value n in register Watchdog_tim_val. When the counter reaches 1, the watchdog timer flag WDTF (register Control_2) is set logic 1 and an interrupt will be generated.

The counter does not automatically reload.

When WD_CD is logic 0 (watchdog timer disabled) and the microcontroller unit (MCU) loads a watchdog timer value n, then:

- the flag WDTF is reset
- $\overline{\text{INT}}$ is cleared
- the watchdog timer starts again

Loading the counter with 0 will:

- reset the flag WDTF
- clear $\overline{\text{INT}}$
- stop the watchdog timer

Remark: WDTF is read only and cannot be cleared by command. WDTF can be cleared by:

- loading a value in register Watchdog_tim_val
- reading of the register Control_2

Writing a logic 0 or logic 1 to WDTF has no effect.

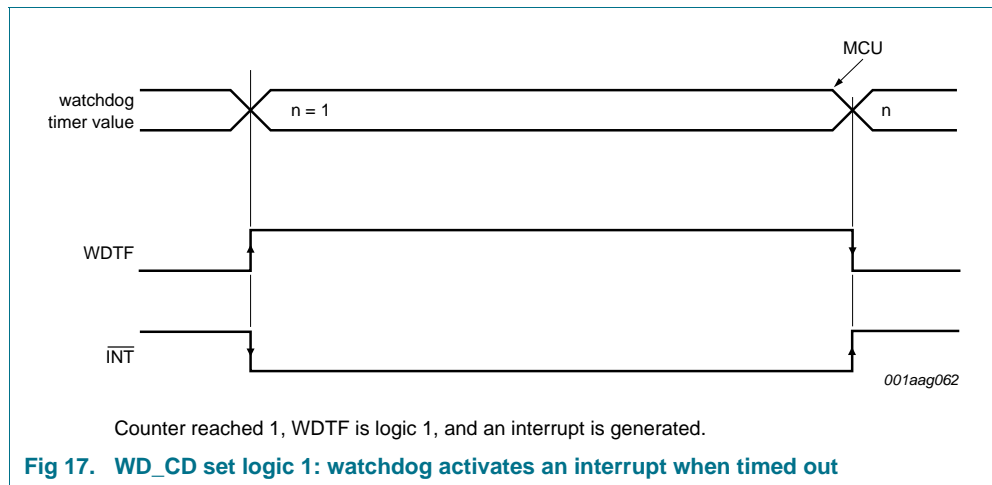

- When the watchdog timer counter reaches 1, the watchdog timer flag WDTF (register Control_2) is set logic 1
- When a minute or second interrupt occurs, the minute/second flag MSF (register Control_2) is set logic 1 (see [Section 8.12.1](#)).

8.10.4 Pre-defined timers: second and minute interrupt

PCA2129T has two pre-defined timers which are used to generate an interrupt either once per second or once per minute. The pulse generator for the minute or second interrupt operates from an internal 64 Hz clock. It is independent of the watchdog timer. Each of these timers can be enabled by the bits SI (second interrupt) and MI (minute interrupt) in register Control_1.

8.10.5 Clearing flags

The flags MSF, AF, and TSFx can be cleared by command. To prevent one flag being overwritten while clearing another, a logic AND is performed during the write access. A flag is cleared by writing logic 0 while a flag is not cleared by writing logic 1. Writing logic 1 will result in the flag value remaining unchanged.

Two examples are given for clearing the flags. Clearing a flag is made by a write command:

- Bits labeled with - must be written with their previous values
- Bits labeled with T have to be written with logic 0
- WDTF is read only and has to be written with logic 0

Repeatedly rewriting these bits has no influence on the functional behavior.

Table 34. Flag location in register Control_2

Register	Bit							
	7	6	5	4	3	2	1	0
Control_2	MSF	WDTF	TSF2	AF	T	-	-	T

Table 35. Example values in register Control_2

Register	Bit							
	7	6	5	4	3	2	1	0
Control_2	1	0	1	1	0	0	0	0

The following tables show what instruction must be sent to clear the appropriate flag.

Table 36. Example to clear only AF (bit 4)

Register	Bit							
	7	6	5	4	3	2	1	0
Control_2	1	0	1	0	0	0 ^[1]	0 ^[1]	0

[1] The bits labeled as - have to be rewritten with the previous values.

Table 37. Example to clear only MSF (bit 7)

Register	Bit							
	7	6	5	4	3	2	1	0
Control_2	0	0	1	1	0	0 ^[1]	0 ^[1]	0

[1] The bits labeled as - have to be rewritten with the previous values.

8.11 Timestamp function

The PCA2129T has an active LOW timestamp input pin $\overline{\text{TS}}$, internally pulled with an on-chip pull-up resistor to the internal power supply of the device. It also has a timestamp detection circuit which can detect two different events:

1. Input on pin $\overline{\text{TS}}$ is driven to an intermediate level between power supply and ground.
2. Input on pin $\overline{\text{TS}}$ is driven to ground.

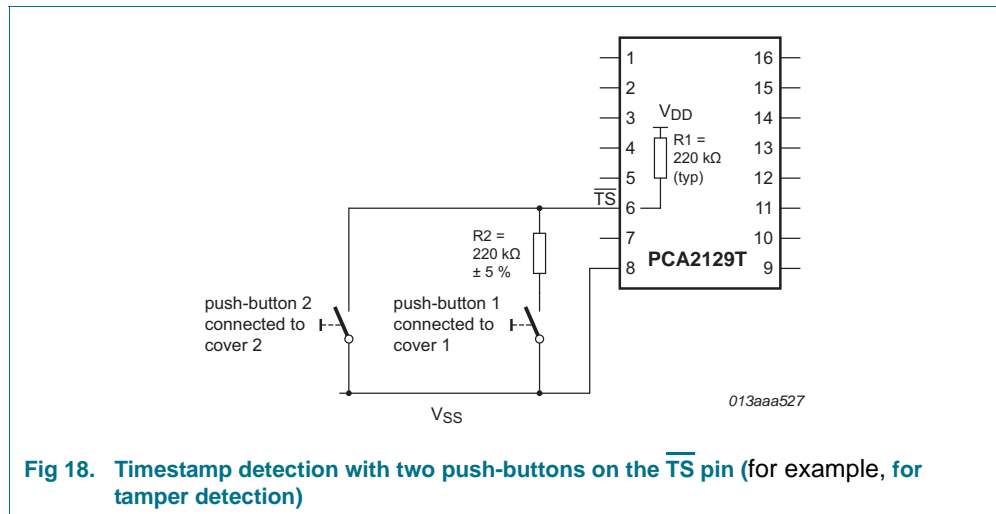

Fig 18. Timestamp detection with two push-buttons on the $\overline{\text{TS}}$ pin (for example, for tamper detection)

The timestamp function is enabled by default after power-on and it can be switched off by setting the control bit TSOFF (register `Timestamp_ctl`).

A most common application of the timestamp function is described in [Ref. 3 "AN11120"](#).

See [Section 8.12.5](#) for a description of interrupt generation from the timestamp function.

8.11.1 Timestamp flag

1. When the $\overline{\text{TS}}$ input pin is driven to an intermediate level between the power supply and ground, then the following sequence occurs:
 - a. The actual date and time are stored in the timestamp registers.
 - b. The timestamp flag TSF1 (register `Control_1`) is set.
 - c. If the TSIE bit (register `Control_2`) is active, an interrupt on the $\overline{\text{INT}}$ pin is generated.

The TSF1 flag can be cleared by command. Clearing the flag will clear the interrupt. Once TSF1 is cleared, it will only be set again when a new negative edge on pin $\overline{\text{TS}}$ is detected.

2. When the $\overline{\text{TS}}$ input pin is driven to ground, the following sequence occurs:
 - a. The actual date and time are stored in the timestamp registers.
 - b. In addition to the TSF1 flag, the TSF2 flag (register `Control_2`) is set.
 - c. If the TSIE bit is active, an interrupt on the $\overline{\text{INT}}$ pin is generated.

The TSF1 and TSF2 flags can be cleared by command; clearing both flags will clear the interrupt. Once TSF2 is cleared, it will only be set again when \overline{TS} pin is driven to ground once again.

8.11.2 Timestamp mode

The timestamp function has two different modes selected by the control bit TSM (timestamp mode) in register Timestp_ctl:

- If TSM is logic 0 (default): in subsequent trigger events without clearing the timestamp flags, the last timestamp event is stored
- If TSM is logic 1: in subsequent trigger events without clearing the timestamp flags, the first timestamp event is stored

The timestamp function also depends on the control bit BTSE in register Control_3, see [Section 8.11.4](#).

8.11.3 Timestamp registers

8.11.3.1 Register Timestp_ctl

Table 38. Timestp_ctl - timestamp control register (address 12h) bit description

Bit	Symbol	Value	Description
7	TSM	0 ^[1]	in subsequent events without clearing the timestamp flags, the last event is stored
		1	in subsequent events without clearing the timestamp flags, the first event is stored
6	TSOFF	0 ^[1]	timestamp function active
		1	timestamp function disabled
5	-	-	unused
4 to 0	1_O_16_TIMESTP[4:0]		$\frac{1}{16}$ second timestamp information coded in BCD format

[1] Default value.

8.11.3.2 Register Sec_timestp

Table 39. Sec_timestp - second timestamp register (address 13h) bit description

Bit	Symbol	Value	Place value	Description
7	-	-	-	unused
6 to 4	SECOND_TIMESTP	0 to 5	ten's place	second timestamp information coded in BCD format
3 to 0		0 to 9	unit place	

8.11.3.3 Register Min_timestp

Table 40. Min_timestp - minute timestamp register (address 14h) bit description

Bit	Symbol	Value	Place value	Description
7	-	-	-	unused
6 to 4	MINUTE_TIMESTP	0 to 5	ten's place	minute timestamp information coded in BCD format
3 to 0		0 to 9	unit place	

8.11.3.4 Register Hour_timestp

Table 41. Hour_timestp - hour timestamp register (address 15h) bit description

Bit	Symbol	Value	Place value	Description
7 to 6	-	-	-	unused
12 hour mode^[1]				
5	AMPM	0	-	indicates AM
		1	-	indicates PM
4	HOUR_TIMESTP	0 to 1	ten's place	hour timestamp information coded in BCD format when in 12 hour mode
3 to 0		0 to 9	unit place	
24 hour mode^[1]				
5 to 4	HOUR_TIMESTP	0 to 2	ten's place	hour timestamp information coded in BCD format when in 24 hour mode
3 to 0		0 to 9	unit place	

[1] Hour mode is set by the bit 12_24 in register Control_1.

8.11.3.5 Register Day_timestp

Table 42. Day_timestp - day timestamp register (address 16h) bit description

Bit	Symbol	Value	Place value	Description
7 to 6	-	-	-	unused
5 to 4	DAY_TIMESTP	0 to 3	ten's place	day timestamp information coded in BCD format
3 to 0		0 to 9	unit place	

8.11.3.6 Register Mon_timestp

Table 43. Mon_timestp - month timestamp register (address 17h) bit description

Bit	Symbol	Value	Place value	Description
7 to 5	-	-	-	unused
4	MONTH_TIMESTP	0 to 1	ten's place	month timestamp information coded in BCD format
3 to 0		0 to 9	unit place	

8.11.3.7 Register Year_timestp

Table 44. Year_timestp - year timestamp register (address 18h) bit description

Bit	Symbol	Value	Place value	Description
7 to 4	YEAR_TIMESTP	0 to 9	ten's place	year timestamp information coded in BCD format
3 to 0		0 to 9	unit place	

8.11.4 Dependency between Battery switch-over and timestamp

The timestamp function depends on the control bit BTSE in register Control_3:

Table 45. Battery switch-over and timestamp

BTSE	BF	Description
0	-	[1] the battery switch-over does not affect the timestamp registers
1		If a battery switch-over event occurs:
	0	[1] the timestamp registers store the time and date when the switch-over occurs; after this event occurred BF is set logic 1
	1	the timestamp registers are not modified; in this condition subsequent battery switch-over events or falling edges on pin \overline{TS} are not registered

[1] Default value.

8.12 Interrupt output, $\overline{\text{INT}}$

PCA2129T has an interrupt output pin $\overline{\text{INT}}$ which is open-drain, active LOW (requiring a pull-up resistor if used). Interrupts may be sourced from different places:

- second or minute timer
- watchdog timer
- alarm
- timestamp
- battery switch-over
- battery low detection

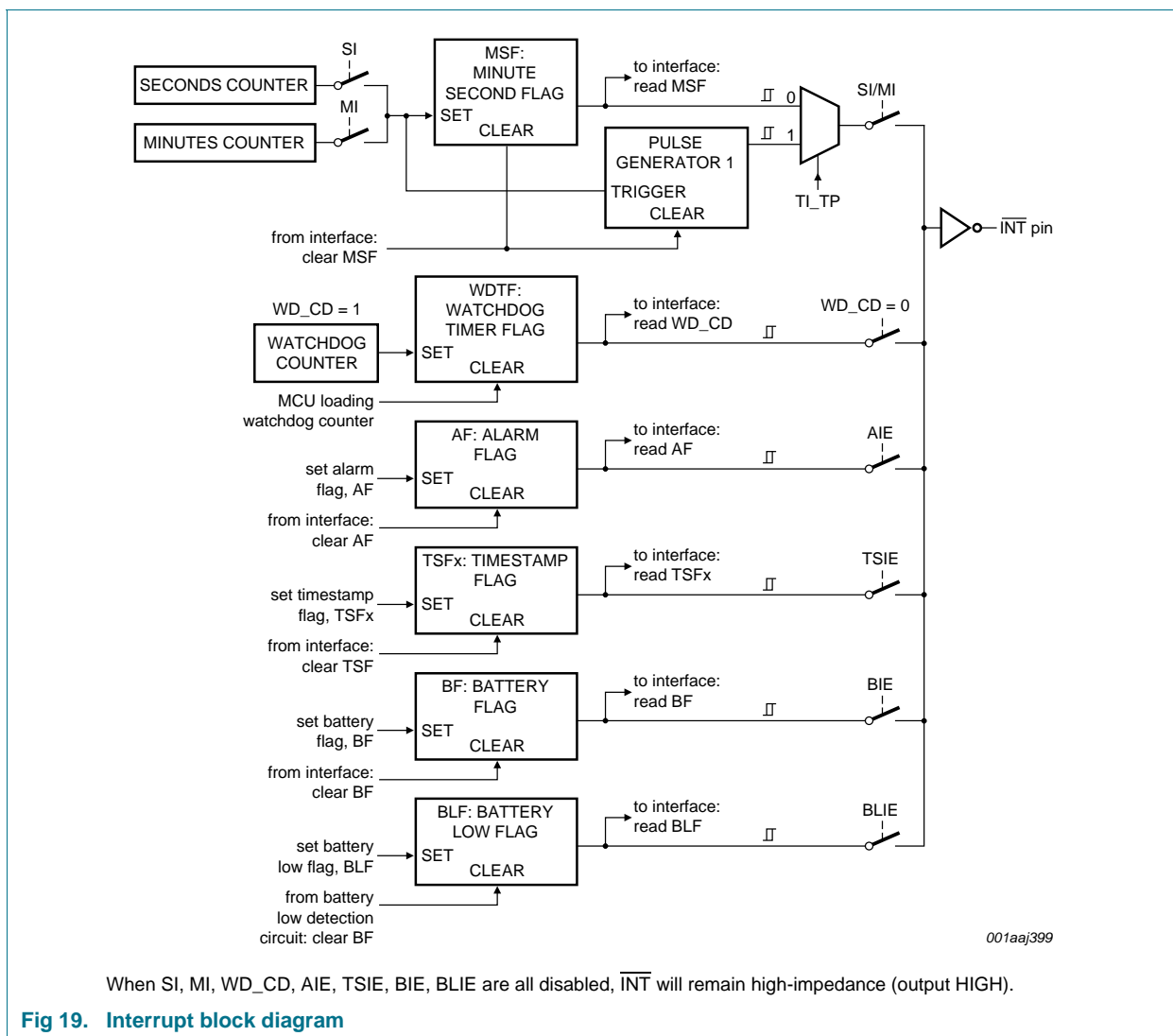

Fig 19. Interrupt block diagram

The control bit TI_TP (register Watchdg_tim_ctl) is used to configure whether the interrupts generated from the second/minute timer (flag MSF in register Control_2) are pulsed signals or a permanently active signal. All the other interrupt sources generate a permanently active interrupt signal which follows the status of the corresponding flags. When the interrupt sources are all disabled, $\overline{\text{INT}}$ remains high-impedance.

- The flags MSF, AF, TSFx, and BF can be cleared by command.
- The flag WDTF is read only. How it can be cleared is explained in [Section 8.10.5](#).
- The flag BLF is read only. It is cleared automatically from the battery low detection circuit when the battery is replaced.

8.12.1 Minute and second interrupts

Minute and second interrupts are generated by predefined timers. The timers can be enabled independently from one another by the bits MI and SI in register Control_1. However, a minute interrupt enabled on top of a second interrupt will not be distinguishable since it will occur at the same time.

The minute/second flag MSF (register Control_2) is set logic 1 when either the seconds or the minutes counter increments according to the enabled interrupt (see [Table 46](#)). The MSF flag can be cleared by command.

Table 46. Effect of bits MI and SI on pin $\overline{\text{INT}}$ and bit MSF

MI	SI	Result on $\overline{\text{INT}}$	Result on MSF
0	0	no interrupt generated	MSF never set
1	0	an interrupt once per minute	MSF set when minutes counter increments
0	1	an interrupt once per second	MSF set when seconds counter increments
1	1	an interrupt once per second	MSF set when seconds counter increments

When MSF is set logic 1:

- If TI_TP is logic 1, the interrupt is generated as a pulsed signal.
- If TI_TP is logic 0, the interrupt is permanently active signal that remains until MSF is cleared.

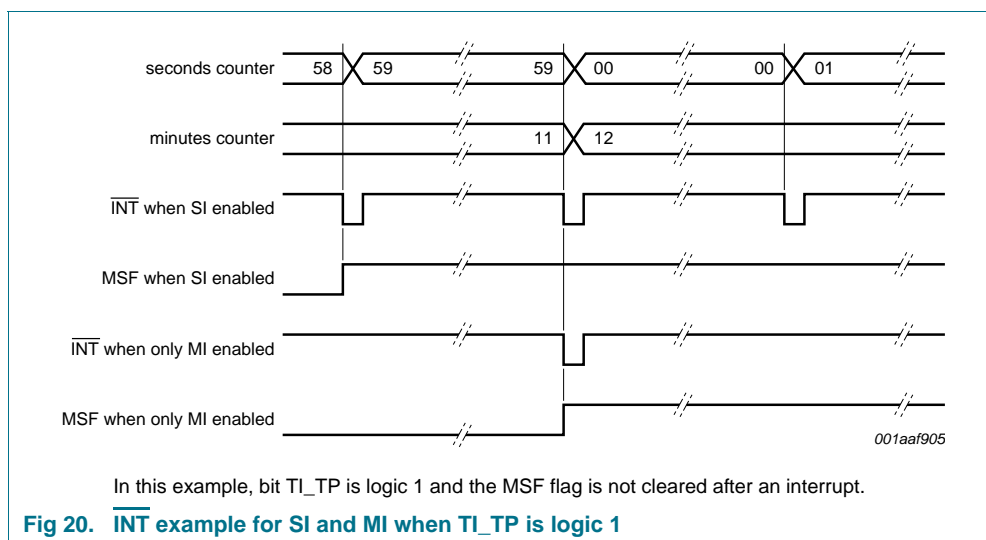

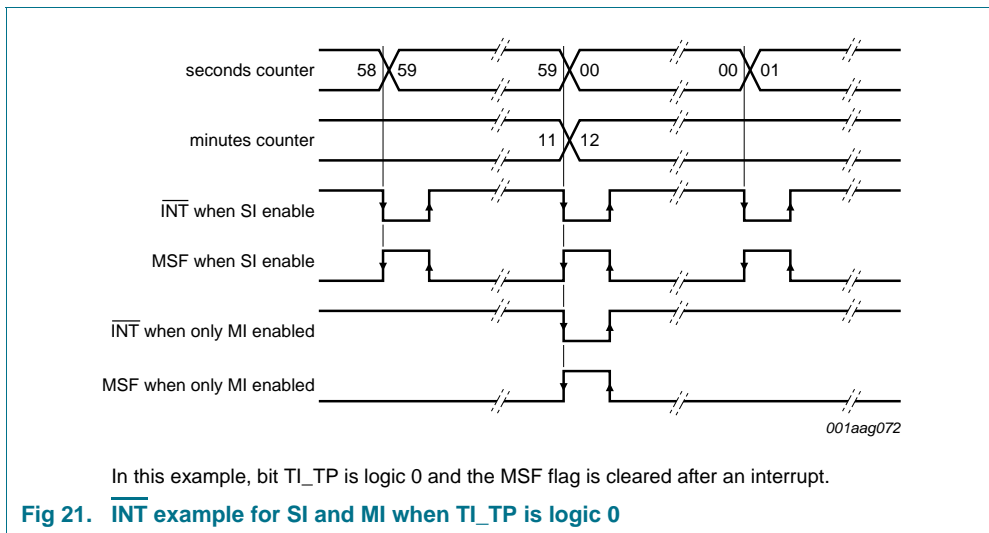

The pulse generator for the minute/second interrupt operates from an internal 64 Hz clock and generates a pulse of $1/64$ seconds in duration.

8.12.2 INT pulse shortening

If the MSF flag (register Control_2) is cleared before the end of the INT pulse, then the INT pulse is shortened. This allows the source of a system interrupt to be cleared immediately when it is serviced, that is, the system does not have to wait for the completion of the pulse before continuing; see Figure 22. Instructions for clearing the bit MSF can be found in Section 8.10.5.

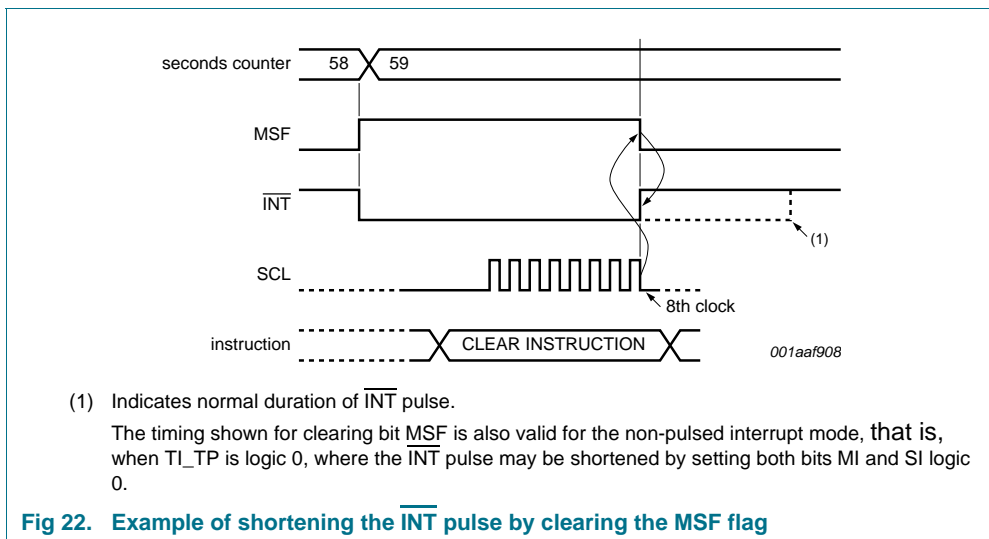

8.12.3 Watchdog timer interrupts

The generation of interrupts from the watchdog timer is controlled using the WD_CD bit (register Watchdog_tim_ctl). The interrupt is generated as an active signal which follows the status of the watchdog timer flag WDTF (register Control_2). No pulse generation is possible for watchdog timer interrupts.

The interrupt is cleared when the flag WDTF is reset. WDTF is a read only bit and cannot be cleared by command. Instructions for clearing it can be found in [Section 8.10.5](#).

8.12.4 Alarm interrupts

Generation of interrupts from the alarm function is controlled by the bit AIE (register Control_2). If AIE is enabled, the $\overline{\text{INT}}$ pin will follow the status of bit AF (register Control_2). Clearing AF will immediately clear $\overline{\text{INT}}$. No pulse generation is possible for alarm interrupts.

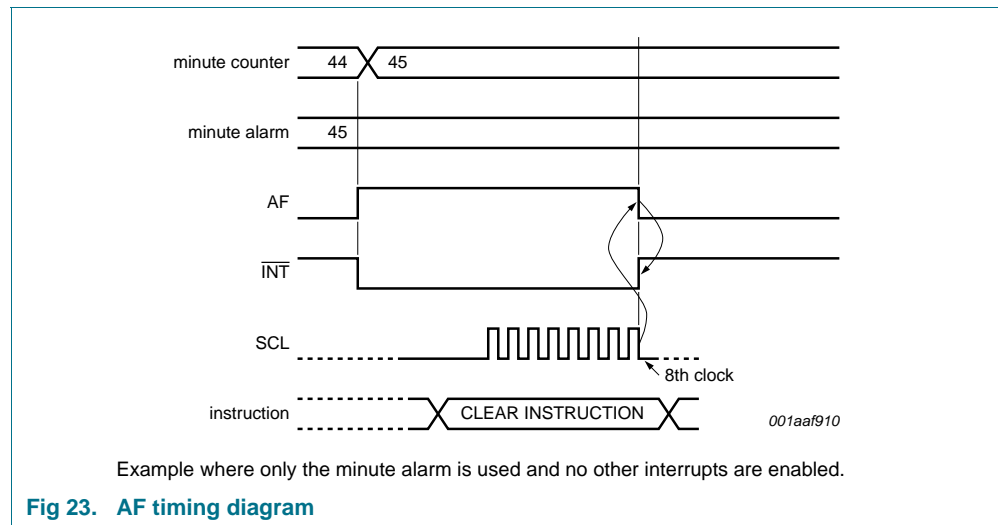

8.12.5 Timestamp interrupts

Interrupt generation from the timestamp function is controlled using the TSIE bit (register Control_2). If TSIE is enabled, the $\overline{\text{INT}}$ pin follows the status of the flags TSF_x. Clearing the flags TSF_x immediately clears $\overline{\text{INT}}$. No pulse generation is possible for timestamp interrupts.

8.12.6 Battery switch-over interrupts

Generation of interrupts from the battery switch-over is controlled by the BIE bit (register Control_3). If BIE is enabled, the $\overline{\text{INT}}$ pin follows the status of bit BF in register Control_3 (see [Table 45](#)). Clearing BF immediately clears $\overline{\text{INT}}$. No pulse generation is possible for battery switch-over interrupts.

8.12.7 Battery low detection interrupts

Generation of interrupts from the battery low detection is controlled by the BLIE bit (register Control_3). If BLIE is enabled, the $\overline{\text{INT}}$ pin will follow the status of bit BLF (register Control_3). The interrupt is cleared when the battery is replaced (BLF is logic 0) or when bit BLIE is disabled (BLIE is logic 0). BLF is read only and therefore cannot be cleared by command.

8.13 External clock test mode

A test mode is available which allows on-board testing. In this mode, it is possible to set up test conditions and control the operation of the RTC.

The test mode is entered by setting bit EXT_TEST logic 1 (register Control_1). Then pin CLKOUT becomes an input. The test mode replaces the internal clock signal (64 Hz) with the signal applied to pin CLKOUT. Every 64 positive edges applied to pin CLKOUT generate an increment of one second.

The signal applied to pin CLKOUT should have a minimum pulse width of 300 ns and a maximum period of 1000 ns. The internal clock, now sourced from CLKOUT, is divided down by a 2^6 divider chain called prescaler (see [Table 47](#)). The prescaler can be set into a known state by using bit STOP. When bit STOP is logic 1, the prescaler is reset to 0. STOP must be cleared before the prescaler can operate again.

From a stop condition, the first 1 second increment will take place after 32 positive edges on pin CLKOUT. Thereafter, every 64 positive edges will cause a 1 second increment.

Remark: Entry into test mode is not synchronized to the internal 64 Hz clock. When entering the test mode, no assumption as to the state of the prescaler can be made.

Operating example:

1. Set EXT_TEST test mode (register Control_1, EXT_TEST is logic 1).
2. Set bit STOP (register Control_1, STOP is logic 1).
3. Set time registers to desired value.
4. Clear STOP (register Control_1, STOP is logic 0).
5. Apply 32 clock pulses to CLKOUT.
6. Read time registers to see the first change.
7. Apply 64 clock pulses to CLKOUT.
8. Read time registers to see the second change.

Repeat 7 and 8 for additional increments.

8.14 STOP bit function

The function of the STOP bit is to allow for accurate starting of the time circuits. STOP will cause the upper part of the prescaler (F_9 to F_{14}) to be held in reset and thus no 1 Hz ticks are generated. The time circuits can then be set and will not increment until the STOP bit is released. STOP will not affect the CLKOUT signal but the output of the prescaler in the range of 32 Hz to 1 Hz (see [Figure 24](#)).

The lower stages of the prescaler, F_0 to F_8 , are not reset and because the I²C-bus and the SPI-bus are asynchronous to the crystal oscillator, the accuracy of restarting the time circuits is between 0 and one 64 Hz cycle (0.484375 s and 0.500000 s), see [Table 47](#) and [Figure 25](#).

Table 47. First increment of time circuits after stop release

Bit STOP	Prescaler bits ^[1] F_0 to F_8 - F_9 to F_{14}	1 Hz tick	Time hh:mm:ss	Comment
Clock is running normally				
0	010000111-010100		12:45:12	prescaler counting normally
STOP bit is activated by user. F_0 to F_8 are not reset and values cannot be predicted externally				
1	xxxxxxxx-000000		12:45:12	prescaler is reset; time circuits are frozen
New time is set by user				
1	xxxxxxxx-000000		08:00:00	prescaler is reset; time circuits are frozen
STOP bit is released by user				
0	xxxxxxxx-000000		08:00:00	prescaler is now running
0	xxxxxxxx-100000		08:00:00	
0	xxxxxxxx-100000		08:00:00	
0	xxxxxxxx-110000		08:00:00	
:	:		:	
0	11111111-111110		08:00:00	
0	00000000-000001		08:00:01	0 to 1 transition of F_{14} increments the time circuits
0	10000000-000001		08:00:01	
:	:		:	
0	11111111-111111		08:00:01	
0	00000000-000000		08:00:01	
0	10000000-000000		08:00:01	
:	:		:	
0	11111111-111110		08:00:01	
0	00000000-000001		08:00:02	0 to 1 transition of F_{14} increments the time circuits

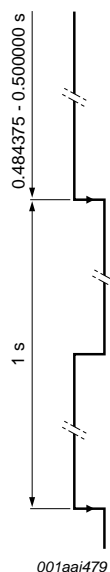

[1] F_0 is clocked at 32.768 kHz.

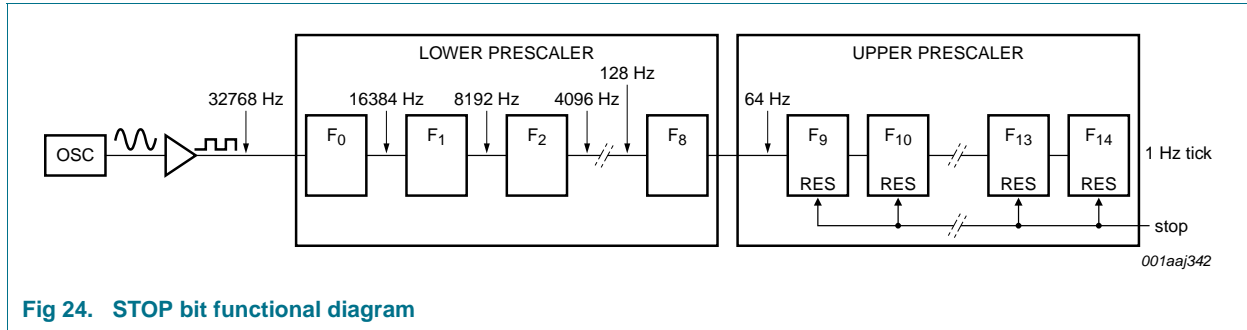

Fig 24. STOP bit functional diagram

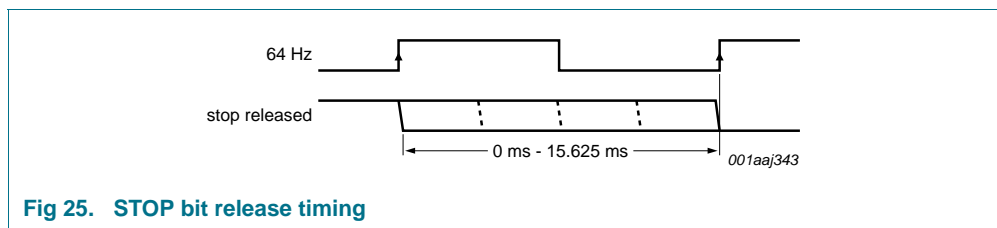

Fig 25. STOP bit release timing

9. Interfaces

The PCA2129T has an I²C-bus or SPI-bus interface using the same pins. The selection is done using the interface selection pin IFS (see [Table 48](#)).

Table 48. Interface selection input pin IFS

Pin	Connection	Bus interface	Reference
IFS	V _{SS}	SPI-bus	Section 9.1
	BBS	I ² C-bus	Section 9.2

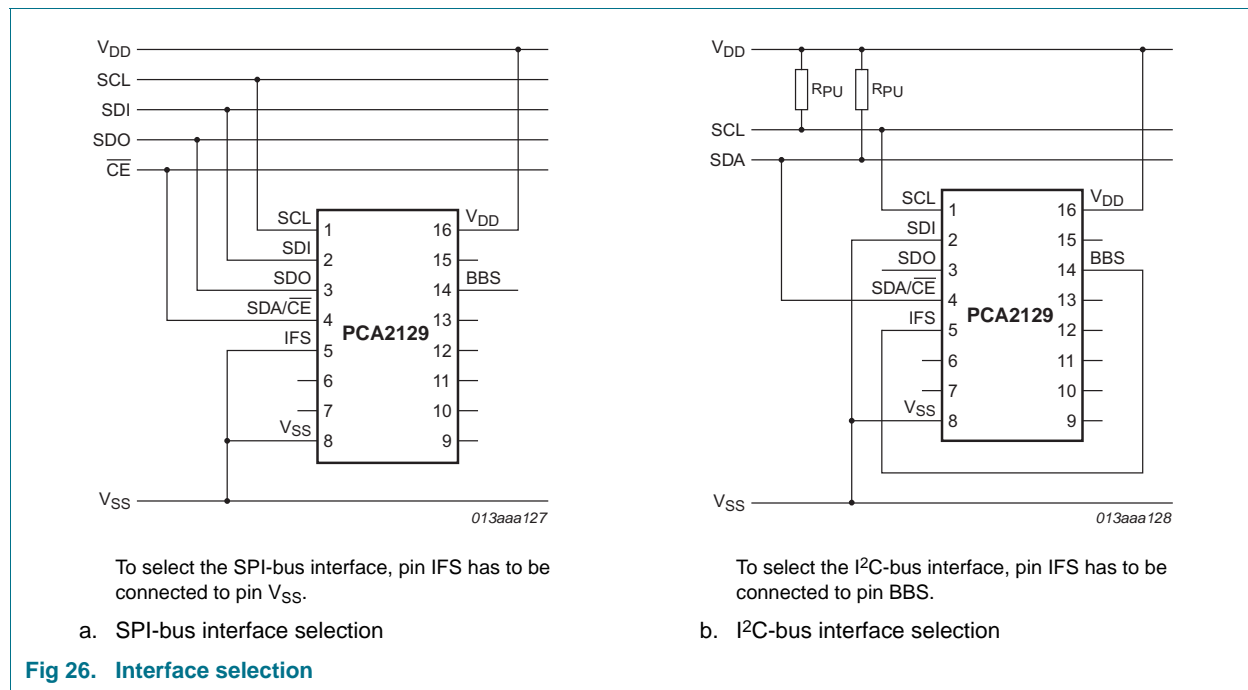

9.1 SPI-bus interface

Data transfer to and from the device is made by a 3 line SPI-bus (see Table 49). The data lines for input and output are split. The data input and output line can be connected together to facilitate a bidirectional data bus (see Figure 27). The SPI-bus is initialized whenever the chip enable line pin SDA/CE is inactive.

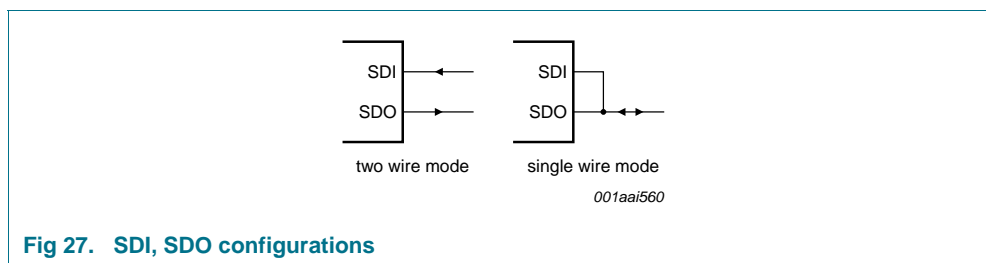

Fig 27. SDI, SDO configurations

Table 49. Serial interface

Symbol	Function	Description
SDA/CE	chip enable input; active LOW	[1] when HIGH, the interface is reset; input may be higher than V _{DD}
SCL	serial clock input	when SDA/CE is HIGH, input may float; input may be higher than V _{DD}
SDI	serial data input	when SDA/CE is HIGH, input may float; input may be higher than V _{DD} ; input data is sampled on the rising edge of SCL
SDO	serial data output	push-pull output; drives from V _{SS} to V _{BBS} ; output data is changed on the falling edge of SCL

[1] The chip enable must not be wired permanently LOW.

9.1.1 Data transmission

The chip enable signal is used to identify the transmitted data. Each data transfer is a whole byte, with the Most Significant Bit (MSB) sent first.

The transmission is controlled by the active LOW chip enable signal SDA/CE. The first byte transmitted is the command byte. Subsequent bytes will be either data to be written or data to be read (see Figure 28).

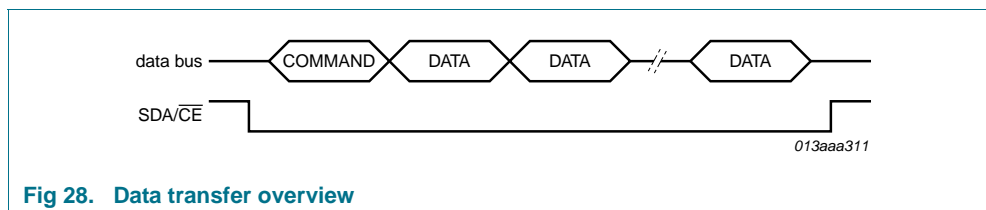

Fig 28. Data transfer overview

The command byte defines the address of the first register to be accessed and the read/write mode. The address counter will auto increment after every access and will reset to zero after the last valid register is accessed. The R/W bit defines if the following bytes will be read or write information.

Table 50. Command byte definition

Bit	Symbol	Value	Description
7	R/W		data read or write selection
		0	write data
		1	read data
6 to 5	SA	01	subaddress; other codes will cause the device to ignore data transfer
4 to 0	RA	00h to 1Bh	register address

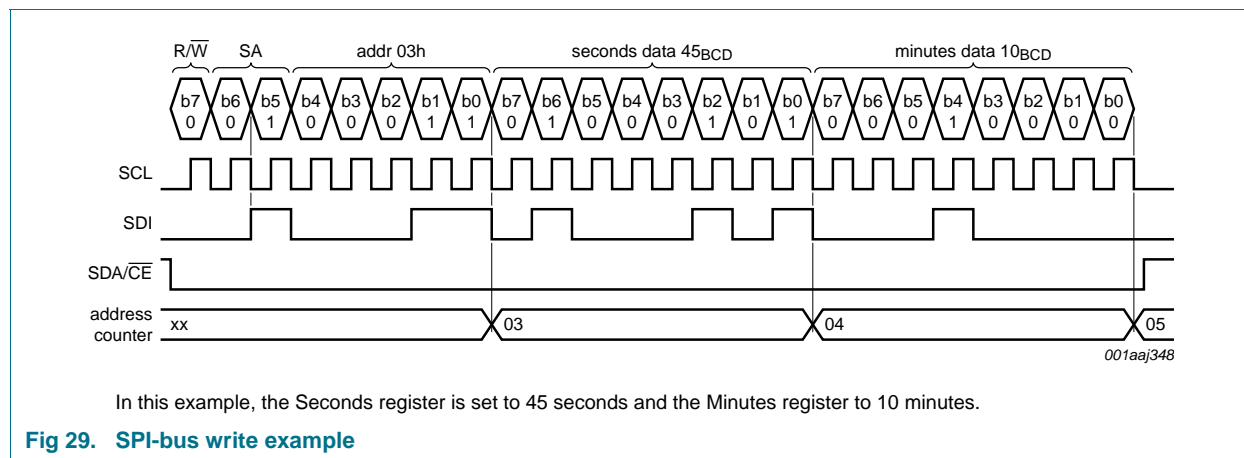

Fig 29. SPI-bus write example

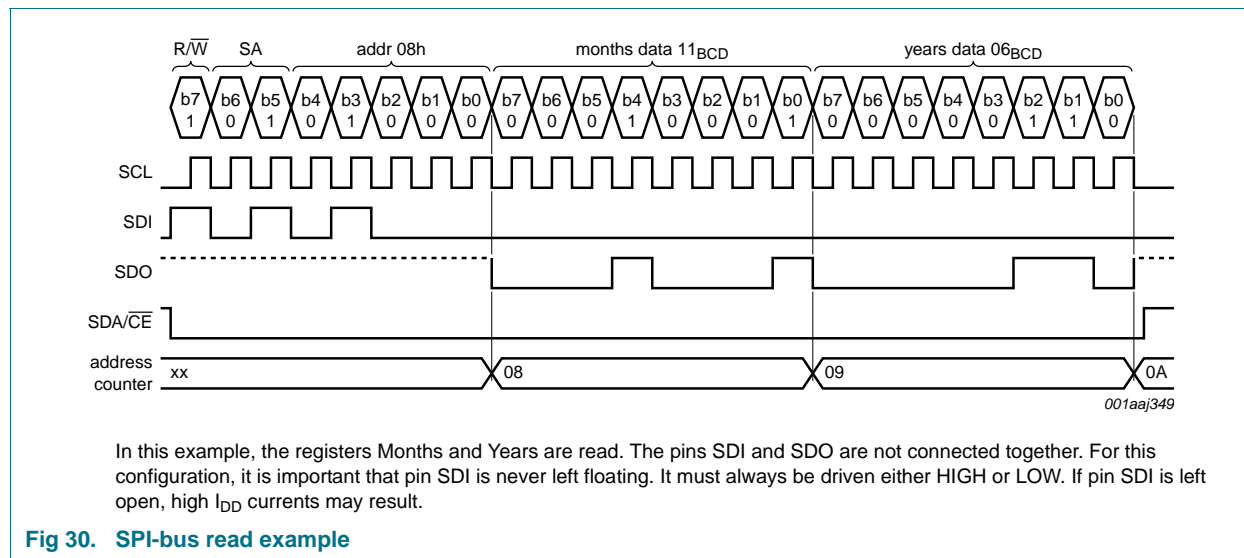

Fig 30. SPI-bus read example

9.2 I²C-bus interface

The I²C-bus is for bidirectional, two-line communication between different ICs or modules. The two lines are a Serial DATA line (SDA) and a Serial CLOCK line (SCL). Both lines are connected to a positive supply by a pull-up resistor. Data transfer is initiated only when the bus is not busy.

9.2.1 Bit transfer

One data bit is transferred during each clock pulse. The data on the SDA line remains stable during the HIGH period of the clock pulse as changes in the data line at this time are interpreted as control signals (see [Figure 31](#)).

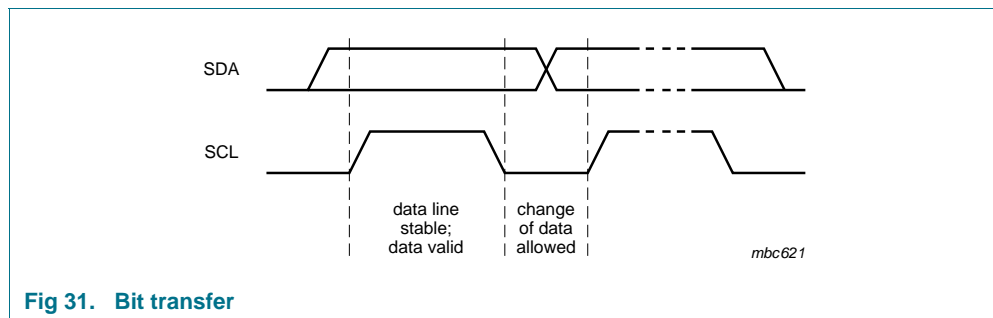

Fig 31. Bit transfer

9.2.2 START and STOP conditions

Both data and clock lines remain HIGH when the bus is not busy. A HIGH-to-LOW transition of the data line, while the clock is HIGH, is defined as the START condition S. A LOW-to-HIGH transition of the data line while the clock is HIGH is defined as the STOP condition P (see [Figure 32](#)).

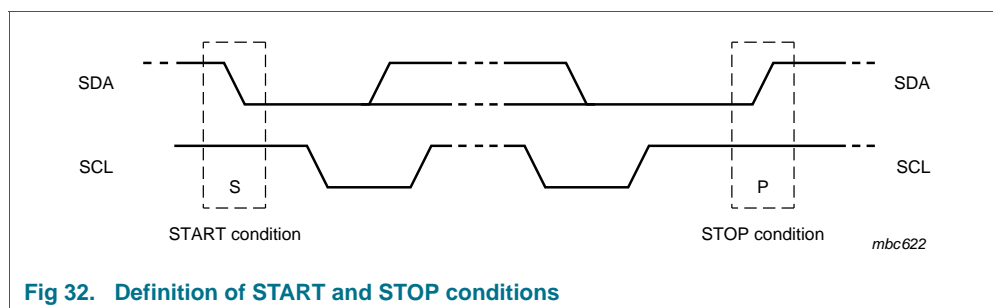

Fig 32. Definition of START and STOP conditions

Remark: For the PCA2129T, a repeated START is not allowed. Therefore a STOP has to be released before the next START.

9.2.3 System configuration

A device generating a message is a transmitter; a device receiving a message is the receiver. The device that controls the message is the master; and the devices which are controlled by the master are the slaves.

The PCA2129T can act as a slave transmitter and a slave receiver.

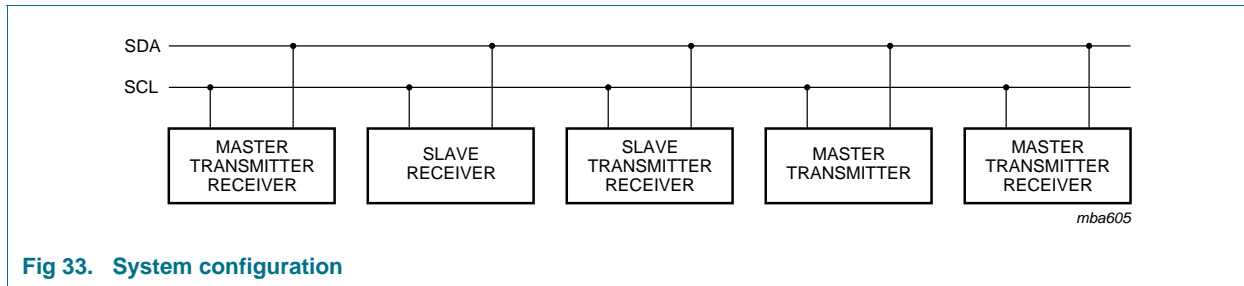

Fig 33. System configuration

9.2.4 Acknowledge

The number of data bytes transferred between the START and STOP conditions from transmitter to receiver is unlimited. Each byte of eight bits is followed by an acknowledge cycle.

- A slave receiver which is addressed must generate an acknowledge after the reception of each byte.
- Also a master receiver must generate an acknowledge after the reception of each byte that has been clocked out of the slave transmitter.
- The device that acknowledges must pull-down the SDA line during the acknowledge clock pulse, so that the SDA line is stable LOW during the HIGH period of the acknowledge related clock pulse (set-up and hold times must be considered).
- A master receiver must signal an end of data to the transmitter by not generating an acknowledge on the last byte that has been clocked out of the slave. In this event, the transmitter must leave the data line HIGH to enable the master to generate a STOP condition.

Acknowledgement on the I²C-bus is illustrated in [Figure 34](#).

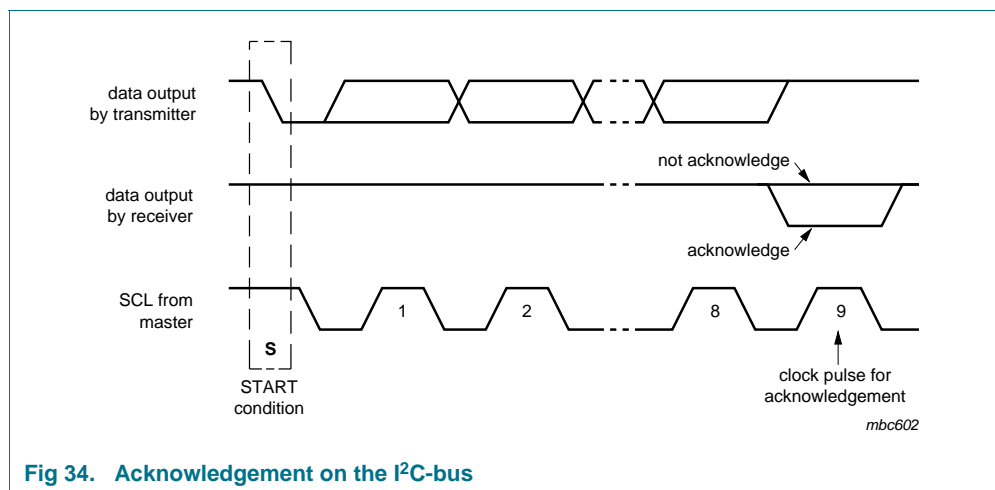

Fig 34. Acknowledgement on the I²C-bus

9.2.5 I²C-bus protocol

After a start condition, a valid hardware address has to be sent to a PCA2129T device. The appropriate I²C-bus slave address is 1010001. The entire I²C-bus slave address byte is shown in [Table 51](#).

Table 51. I²C slave address byte

Bit	Slave address							0 LSB
	7 MSB	6	5	4	3	2	1	
	1	0	1	0	0	0	1	R/W

The R/W bit defines the direction of the following single or multiple byte data transfer (read is logic 1, write is logic 0).

For the format and the timing of the START condition (S), the STOP condition (P), and the acknowledge (A) refer to the I²C-bus specification [Ref. 11 “UM10204”](#) and the characteristics table ([Table 56](#)). In the write mode, a data transfer is terminated by sending either a STOP condition or the START condition of the next data transfer.

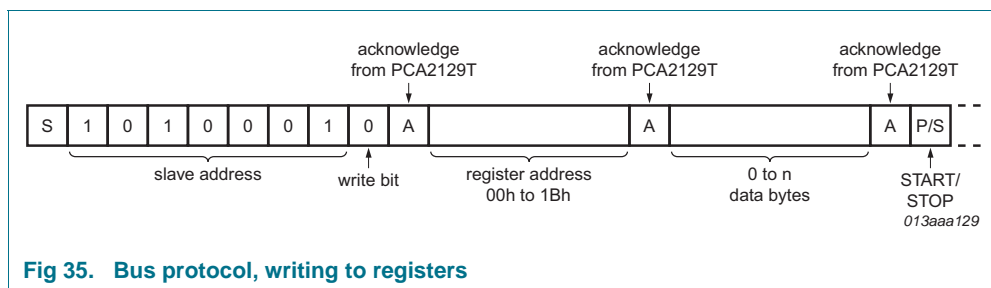

Fig 35. Bus protocol, writing to registers

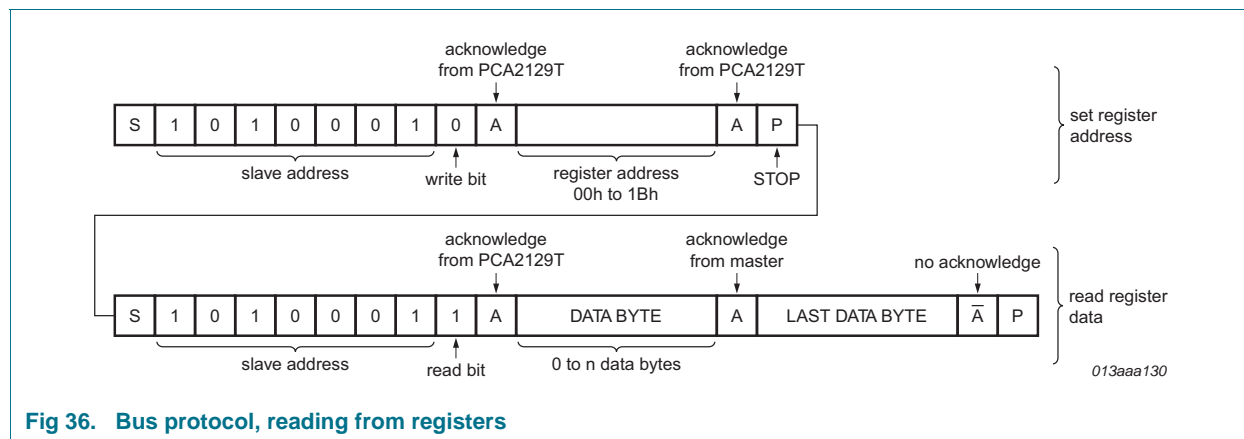

Fig 36. Bus protocol, reading from registers

10. Internal circuitry

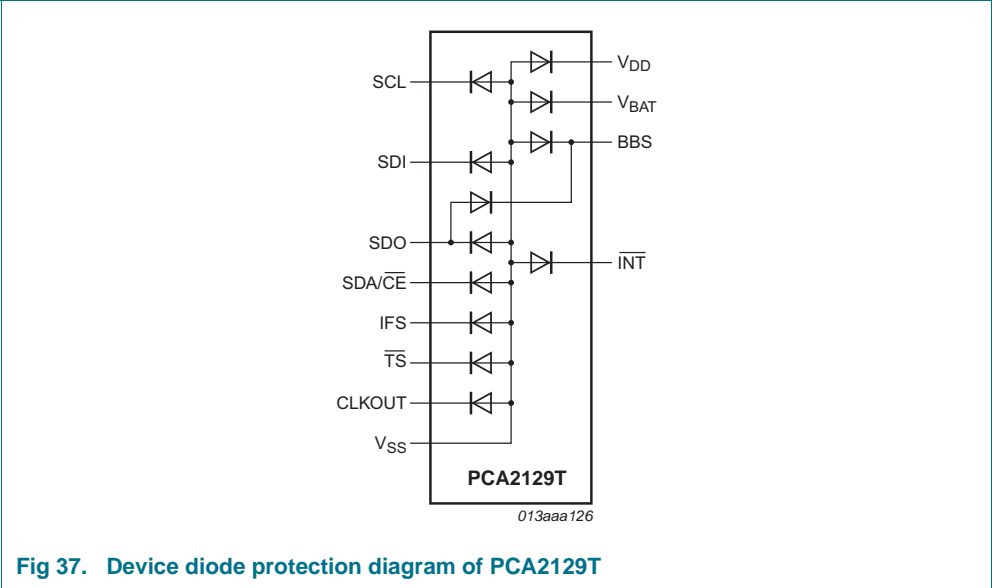

Fig 37. Device diode protection diagram of PCA2129T

11. Limiting values

Table 52. Limiting values

In accordance with the Absolute Maximum Rating System (IEC 60134).

Symbol	Parameter	Conditions	Min	Max	Unit
V_{DD}	supply voltage		-0.5	+6.5	V
I_{DD}	supply current		-50	+50	mA
V_i	input voltage		-0.5	+6.5	V
I_i	input current		-10	+10	mA
V_O	output voltage		-0.5	+6.5	V
I_O	output current		-10	+10	mA
		at pin SDA/CE	-10	+20	mA
V_{BAT}	battery supply voltage		-0.5	+6.5	V
P_{tot}	total power dissipation		-	300	mW
V_{ESD}	electrostatic discharge voltage	HBM	[1] -	±4000	V
		CDM	[2] -	±1250	V
I_{lu}	latch-up current		[3] -	200	mA
T_{stg}	storage temperature		[4] -55	+85	°C
T_{amb}	ambient temperature	operating device	-40	+85	°C

[1] Pass level; Human Body Model (HBM) according to [Ref. 7 "JESD22-A114"](#).

[2] Pass level; Charged-Device Model (CDM), according to [Ref. 8 "JESD22-C101"](#).

[3] Pass level; latch-up testing according to [Ref. 9 "JESD78"](#) at maximum ambient temperature ($T_{amb(max)}$).

[4] According to the store and transport requirements (see [Ref. 12 "UM10569"](#)) the devices have to be stored at a temperature of +8 °C to +45 °C and a humidity of 25 % to 75 %.

12. Static characteristics

Table 53. Static characteristics
 $V_{DD} = 1.8\text{ V to }4.2\text{ V}$; $V_{SS} = 0\text{ V}$; $T_{amb} = -40\text{ }^{\circ}\text{C to }+85\text{ }^{\circ}\text{C}$, unless otherwise specified.

Symbol	Parameter	Conditions	Min	Typ	Max	Unit
Supplies						
V_{DD}	supply voltage		[1] 1.8	-	4.2	V
V_{BAT}	battery supply voltage		1.8	-	4.2	V
$V_{DD(cal)}$	calibration supply voltage		-	3.3	-	V
V_{low}	low voltage		-	1.2	-	V
I_{DD}	supply current	interface active; supplied by V_{DD}				
		SPI-bus ($f_{SCL} = 6.5\text{ MHz}$)	-	-	800	μA
		I ² C-bus ($f_{SCL} = 400\text{ kHz}$)	-	-	200	μA
		interface inactive ($f_{SCL} = 0\text{ Hz}$)[2]; TCR[1:0] = 00 (see Table 9 on page 12)				
		PWRMNG[2:0] = 111 (see Table 14 on page 15); TSOFF = 1 (see Table 38 on page 35); COF[2:0] = 111 (see Table 11 on page 13)				
		$V_{DD} = 2.0\text{ V}$	-	500	-	nA
		$V_{DD} = 3.3\text{ V}$	-	700	1500	nA
		$V_{DD} = 4.2\text{ V}$	-	800	-	nA
		PWRMNG[2:0] = 111 (see Table 14 on page 15); TSOFF = 1 (see Table 38 on page 35); COF[2:0] = 000 (see Table 11 on page 13)				
		$V_{DD} = 2.0\text{ V}$	-	600	-	nA
		$V_{DD} = 3.3\text{ V}$	-	850	-	nA
		$V_{DD} = 4.2\text{ V}$	-	1050	-	nA
		PWRMNG[2:0] = 000 (see Table 14 on page 15); TSOFF = 0 (see Table 38 on page 35); COF[2:0] = 111 (see Table 11 on page 13)				
		V_{DD} or $V_{BAT} = 2.0\text{ V}$	[3] -	1800	-	nA
		V_{DD} or $V_{BAT} = 3.3\text{ V}$	[3] -	2150	-	nA
		V_{DD} or $V_{BAT} = 4.2\text{ V}$	[3] -	2350	3500	nA
		PWRMNG[2:0] = 000 (see Table 14 on page 15); TSOFF = 0 (see Table 38 on page 35); COF[2:0] = 000 (see Table 11 on page 13)				
		V_{DD} or $V_{BAT} = 2.0\text{ V}$	[3] -	1900	-	nA
		V_{DD} or $V_{BAT} = 3.3\text{ V}$	[3] -	2300	-	nA
		V_{DD} or $V_{BAT} = 4.2\text{ V}$	[3] -	2600	-	nA
$I_{L(bat)}$	battery leakage current	V_{DD} is active supply; $V_{BAT} = 3.0\text{ V}$	-	50	100	nA
Power management						
$V_{th(sw)bat}$	battery switch threshold voltage		-	2.5	-	V
$V_{th(bat)low}$	low battery threshold voltage		-	2.5	-	V

Table 53. Static characteristics ...continued $V_{DD} = 1.8\text{ V to }4.2\text{ V}$; $V_{SS} = 0\text{ V}$; $T_{amb} = -40\text{ }^{\circ}\text{C to }+85\text{ }^{\circ}\text{C}$, unless otherwise specified.

Symbol	Parameter	Conditions	Min	Typ	Max	Unit
Inputs^[4]						
V_I	input voltage		-0.5	-	$V_{DD} + 0.5$	V
V_{IL}	LOW-level input voltage		-	-	$0.25V_{DD}$	V
		$T_{amb} = -20\text{ }^{\circ}\text{C to }+85\text{ }^{\circ}\text{C}$; $V_{DD} > 2.0\text{ V}$	-	-	$0.3V_{DD}$	V
V_{IH}	HIGH-level input voltage		$0.7V_{DD}$	-	-	V
I_{LI}	input leakage current	$V_I = V_{DD}$ or V_{SS}	-	0	-	μA
		post ESD event	-1	-	+1	μA
C_i	input capacitance		^[5] -	-	7	pF
Outputs						
V_O	output voltage	on pins CLKOUT, $\overline{\text{INT}}$, referring to external pull-up	-0.5	-	5.5	V
		on pin SDO	-0.5	-	$V_{BBS} + 0.5$	V
I_{OL}	LOW-level output current	output sink current; $V_{OL} = 0.4\text{ V}$				
		on pin SDA/ $\overline{\text{CE}}$	^[6] 3	17	-	mA
		on all other outputs	1.0	-	-	mA
I_{OH}	HIGH-level output current	output source current; on pin SDO; $V_{OH} = 3.8\text{ V}$; $V_{DD} = 4.2\text{ V}$	1.0	-	-	mA
I_{LO}	output leakage current	$V_O = V_{DD}$ or V_{SS}	-	0	-	μA
		post ESD event	-1	-	+1	μA

[1] For reliable oscillator start-up at power-on: $V_{DD(po)min} = V_{DD(min)} + 0.3\text{ V}$.

[2] Timer source clock = $1/60\text{ Hz}$, level of pins SDA/ $\overline{\text{CE}}$, SDI, and SCL is V_{DD} or V_{SS} .

[3] When the device is supplied by the V_{BAT} pin instead of the V_{DD} pin, the current values for I_{BAT} will be as specified for I_{DD} under the same conditions.

[4] The I²C-bus interface of PCA2129T is 5 V tolerant.

[5] Tested on sample basis.

[6] For further information, see [Figure 38](#).

12.1 Current consumption characteristics, typical

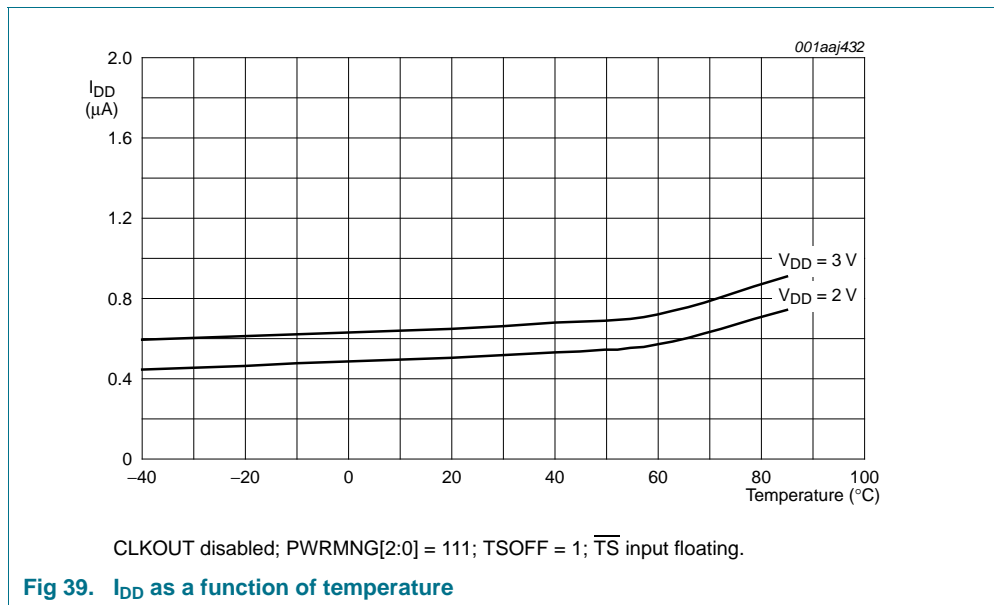
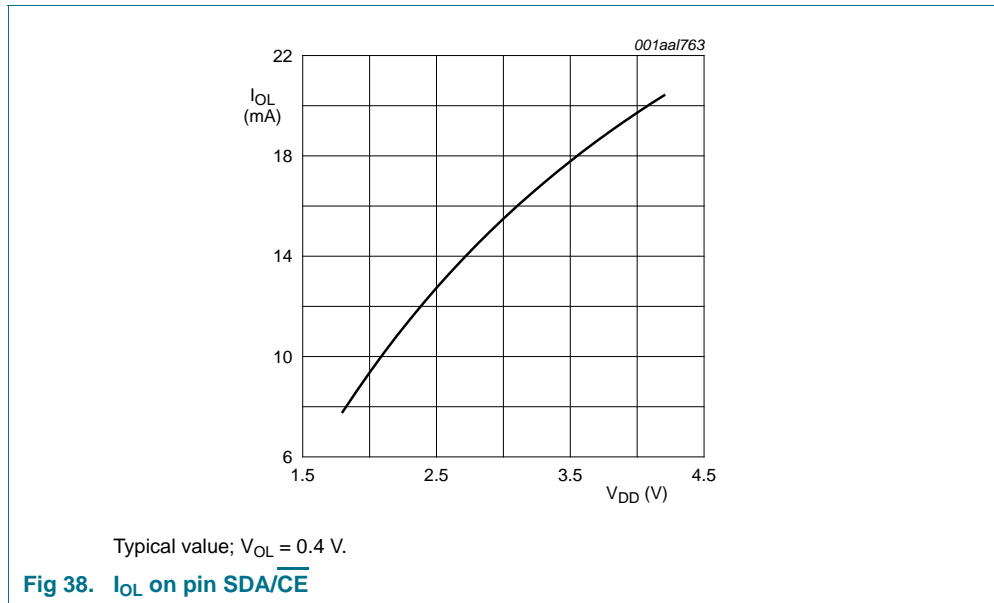

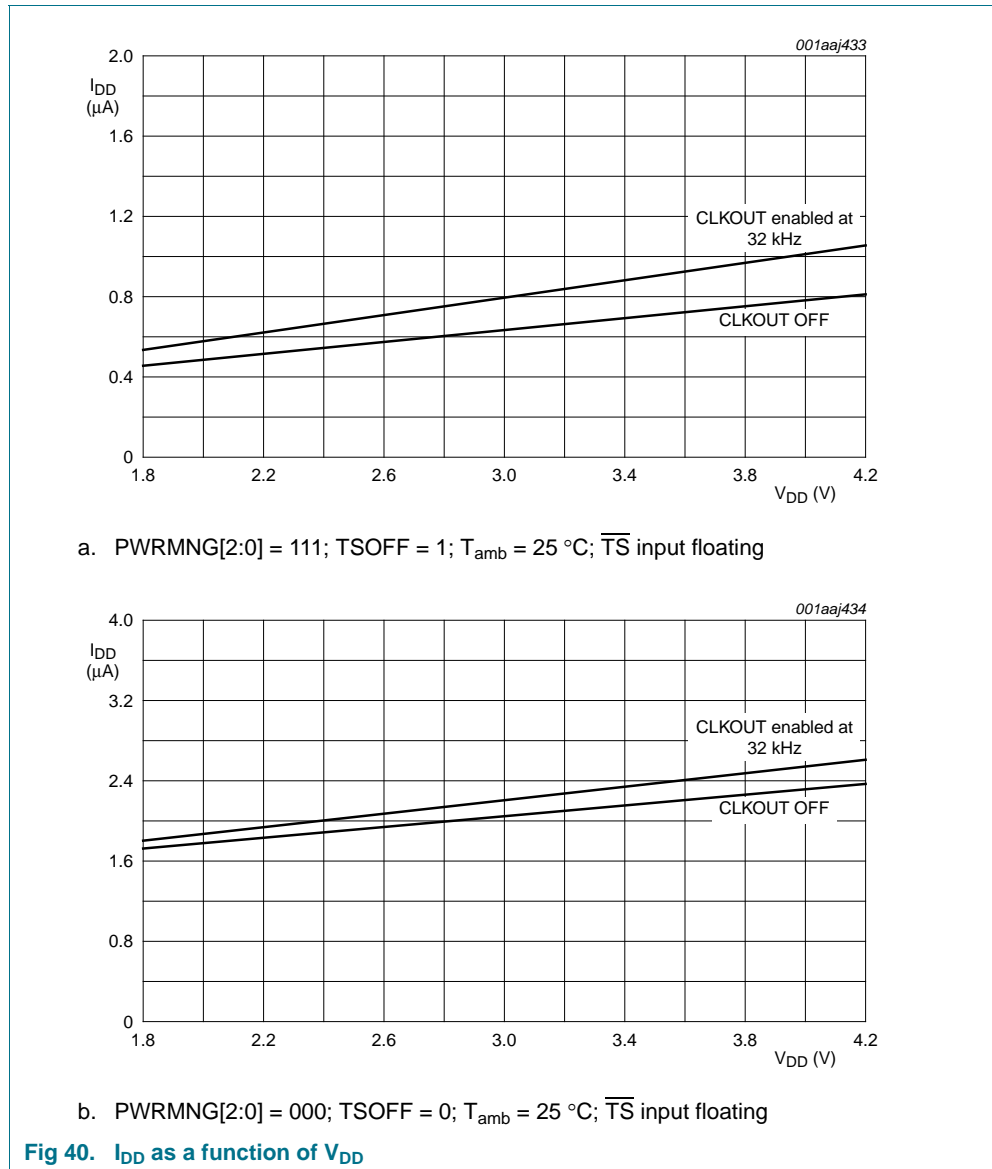

12.2 Frequency characteristics

Table 54. Frequency characteristics

$V_{DD} = 1.8\text{ V to }4.2\text{ V}$; $V_{SS} = 0\text{ V}$; $T_{amb} = +25\text{ }^{\circ}\text{C}$, unless otherwise specified.

Symbol	Parameter	Conditions	Min	Typ	Max	Unit
f_o	output frequency	on pin CLKOUT; V_{DD} or $V_{BAT} = 3.3\text{ V}$; COF[2:0] = 000; AO[3:0] = 1000	-	32.768	-	kHz
$\Delta f/f$	frequency stability	V_{DD} or $V_{BAT} = 3.3\text{ V}$				
		$T_{amb} = -30\text{ }^{\circ}\text{C to }+80\text{ }^{\circ}\text{C}$	[1][2]	-	± 3	± 8 ppm
		$T_{amb} = -40\text{ }^{\circ}\text{C to }-30\text{ }^{\circ}\text{C}$ and $T_{amb} = +80\text{ }^{\circ}\text{C to }+85\text{ }^{\circ}\text{C}$	[1][2]	-	± 5	± 15 ppm
$\Delta f_{xtal}/f_{xtal}$	relative crystal frequency variation	crystal aging				
		first year	[3]	-	-	± 3 ppm
		ten years	-	-	-	± 8 ppm
$\Delta f/\Delta V$	frequency variation with voltage	on pin CLKOUT	-	± 1	-	ppm/V

[1] ± 1 ppm corresponds to a time deviation of ± 0.0864 seconds per day.

[2] Only valid if CLKOUT frequencies are not equal to 32.768 kHz or if CLKOUT is disabled.

[3] Not production tested. Effects of reflow soldering are included (see [Ref. 3 "AN11120"](#)).

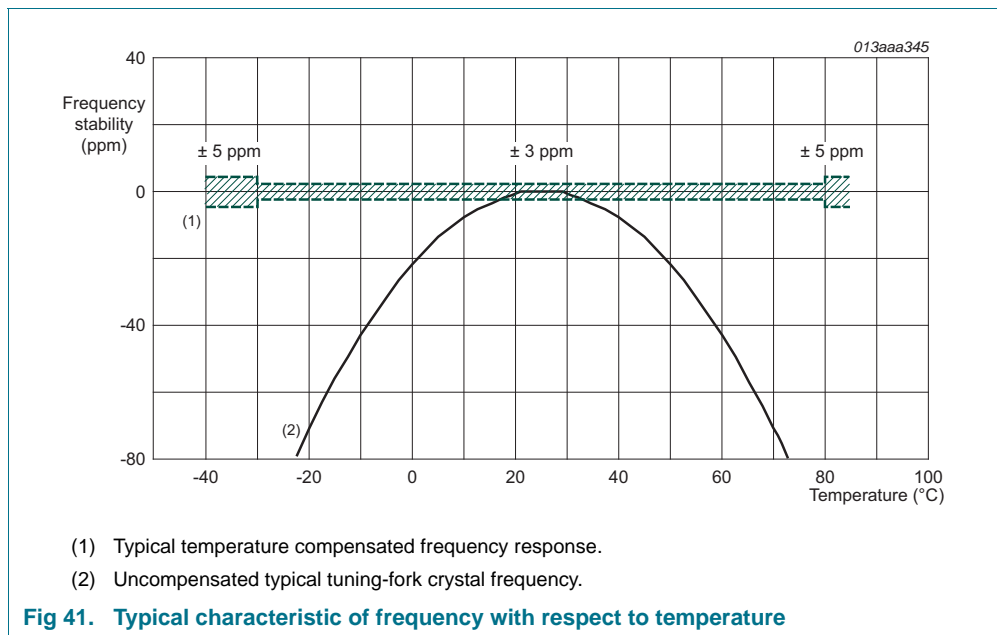

13. Dynamic characteristics

13.1 SPI-bus timing characteristics

Table 55. SPI-bus characteristics

$V_{DD} = 1.8\text{ V to }4.2\text{ V}$; $V_{SS} = 0\text{ V}$; $T_{amb} = -40\text{ }^{\circ}\text{C to }+85\text{ }^{\circ}\text{C}$, unless otherwise specified. All timing values are valid within the operating supply voltage at ambient temperature and referenced to V_{IL} and V_{IH} with an input voltage swing of V_{SS} to V_{DD} (see [Figure 42](#)).

Symbol	Parameter	Conditions	$V_{DD} = 1.8\text{ V}$		$V_{DD} = 4.2\text{ V}$		Unit
			Min	Max	Min	Max	
Pin SCL							
$f_{clk(SCL)}$	SCL clock frequency		-	2.0	-	6.5	MHz
t_{SCL}	SCL time		800	-	140	-	ns
$t_{clk(H)}$	clock HIGH time		100	-	70	-	ns
$t_{clk(L)}$	clock LOW time		400	-	70	-	ns
t_r	rise time	for SCL signal	-	100	-	30	ns
t_f	fall time	for SCL signal	-	100	-	30	ns
Pin SDA/CE							
$t_{su(CE_N)}$	CE_N set-up time		60	-	30	-	ns
$t_{h(CE_N)}$	CE_N hold time		40	-	25	-	ns
$t_{rec(CE_N)}$	CE_N recovery time		100	-	30	-	ns
$t_{w(CE_N)}$	CE_N pulse width		-	0.99	-	0.99	s
Pin SDI							
t_{su}	set-up time	set-up time for SDI data	70	-	20	-	ns
t_h	hold time	hold time for SDI data	70	-	20	-	ns
Pin SDO							
$t_{d(R)SDO}$	SDO read delay time	$C_L = 50\text{ pF}$	-	225	-	55	ns
$t_{dis(SDO)}$	SDO disable time	[1]	-	90	-	25	ns
$t_{t(SDI-SDO)}$	transition time from SDI to SDO	to avoid bus conflict	0	-	0	-	ns

[1] No load value; bus will be held up by bus capacitance; use RC time constant with application values.

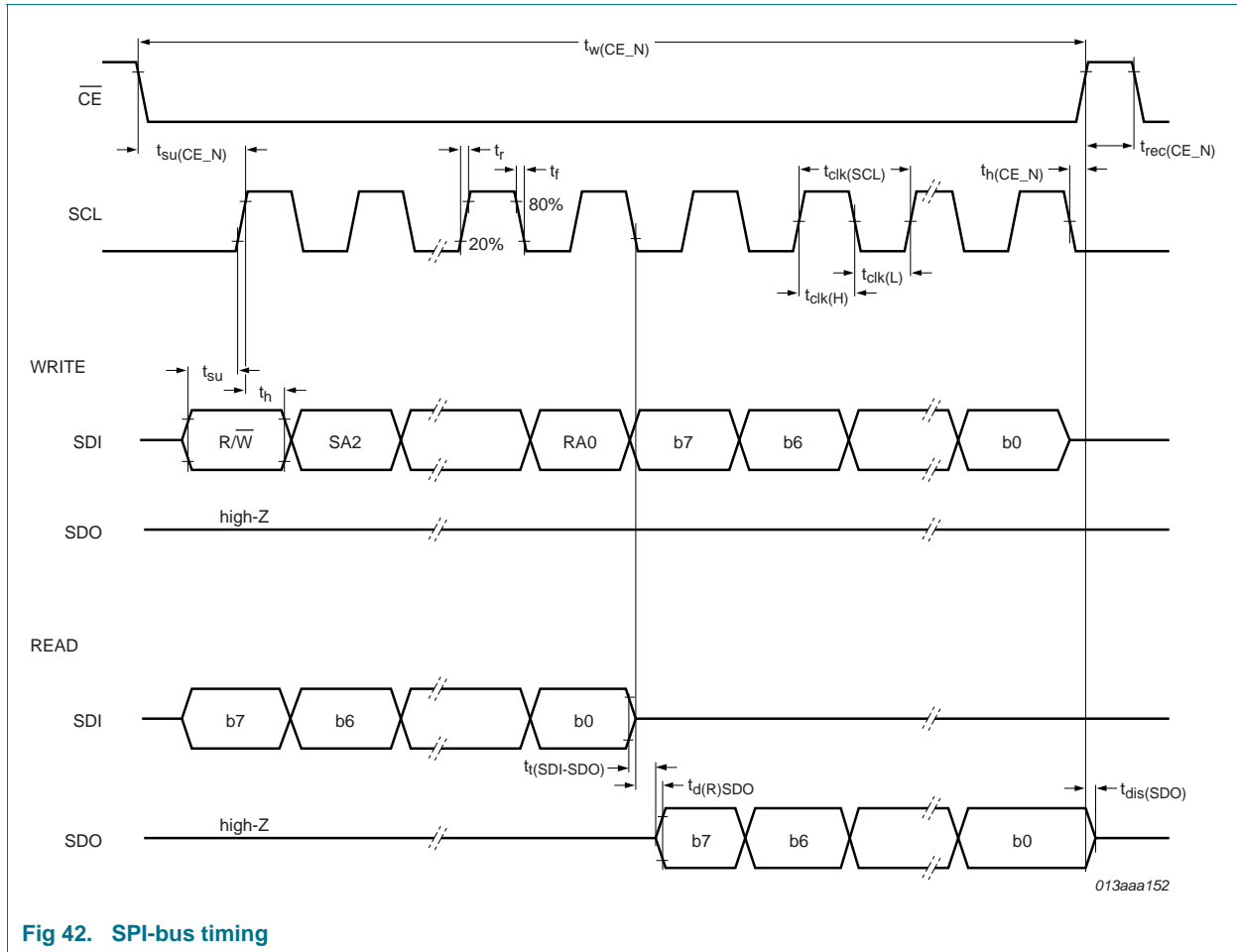

Fig 42. SPI-bus timing

13.2 I²C-bus timing characteristics

Table 56. I²C-bus characteristics

All timing characteristics are valid within the operating supply voltage and ambient temperature range and reference to 30 % and 70 % with an input voltage swing of V_{SS} to V_{DD} (see [Figure 43](#)).

Symbol	Parameter	Standard mode		Fast-mode (Fm)		Unit
		Min	Max	Min	Max	
Pin SCL						
f_{SCL}	SCL clock frequency	[1] 0	100	0	400	kHz
t_{LOW}	LOW period of the SCL clock	4.7	-	1.3	-	μ s
t_{HIGH}	HIGH period of the SCL clock	4.0	-	0.6	-	μ s
Pin SDA/CE						
$t_{SU;DAT}$	data set-up time	250	-	100	-	ns
$t_{HD;DAT}$	data hold time	0	-	0	-	ns
Pins SCL and SDA/CE						
t_{BUF}	bus free time between a STOP and START condition	4.7	-	1.3	-	μ s
$t_{SU;STO}$	set-up time for STOP condition	4.0	-	0.6	-	μ s
$t_{HD;STA}$	hold time (repeated) START condition	4.0	-	0.6	-	μ s
$t_{SU;STA}$	set-up time for a repeated START condition	4.7	-	0.6	-	μ s
t_r	rise time of both SDA and SCL signals	[2][3][4] -	1000	$20 + 0.1C_b$	300	ns
t_f	fall time of both SDA and SCL signals	[2][3][4] -	300	$20 + 0.1C_b$	300	ns
$t_{VD;ACK}$	data valid acknowledge time	[5] 0.1	3.45	0.1	0.9	μ s
$t_{VD;DAT}$	data valid time	[6] 300	-	75	-	ns
t_{SP}	pulse width of spikes that must be suppressed by the input filter	[7] -	50	-	50	ns

[1] The minimum SCL clock frequency is limited by the bus time-out feature which resets the serial bus interface if either the SDA or SCL is held LOW for a minimum of 25 ms. The bus time-out feature must be disabled for DC operation.

[2] A master device must internally provide a hold time of at least 300 ns for the SDA signal (refer to the V_{IL} of the SCL signal) in order to bridge the undefined region of the falling edge of SCL.

[3] C_b is the total capacitance of one bus line in pF.

[4] The maximum t_f for the SDA and SCL bus lines is 300 ns. The maximum fall time for the SDA output stage, t_f is 250 ns. This allows series protection resistors to be connected between the SDA/CE pin, the SCL pin, and the SDA/SCL bus lines without exceeding the maximum t_f .

[5] $t_{VD;ACK}$ is the time of the acknowledgement signal from SCL LOW to SDA (out) LOW.

[6] $t_{VD;DAT}$ is the minimum time for valid SDA (out) data following SCL LOW.

[7] Input filters on the SDA and SCL inputs suppress noise spikes of less than 50 ns.

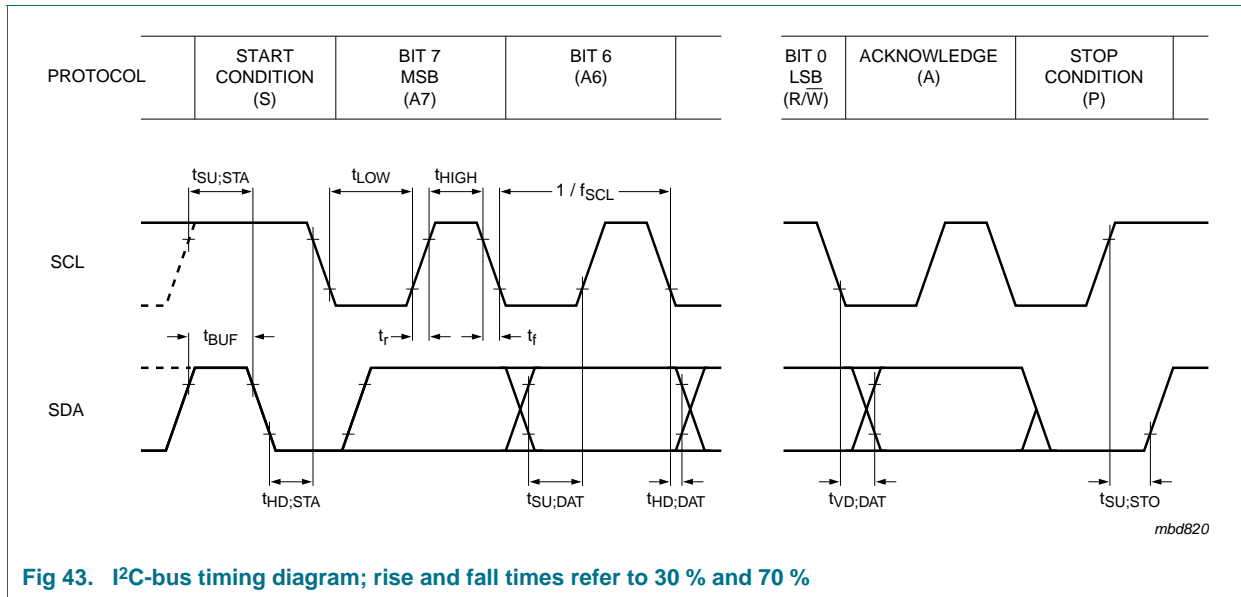

14. Application information

For information about application configuration see [Ref. 3 "AN11120"](#).

15. Test information

15.1 Quality information

This product has been qualified in accordance with the Automotive Electronics Council (AEC) standard Q100 - *Failure mechanism based stress test qualification for integrated circuits*, and is suitable for use in automotive applications.

16. Package outline

SO16: plastic small outline package; 16 leads; body width 7.5 mm

SOT162-1

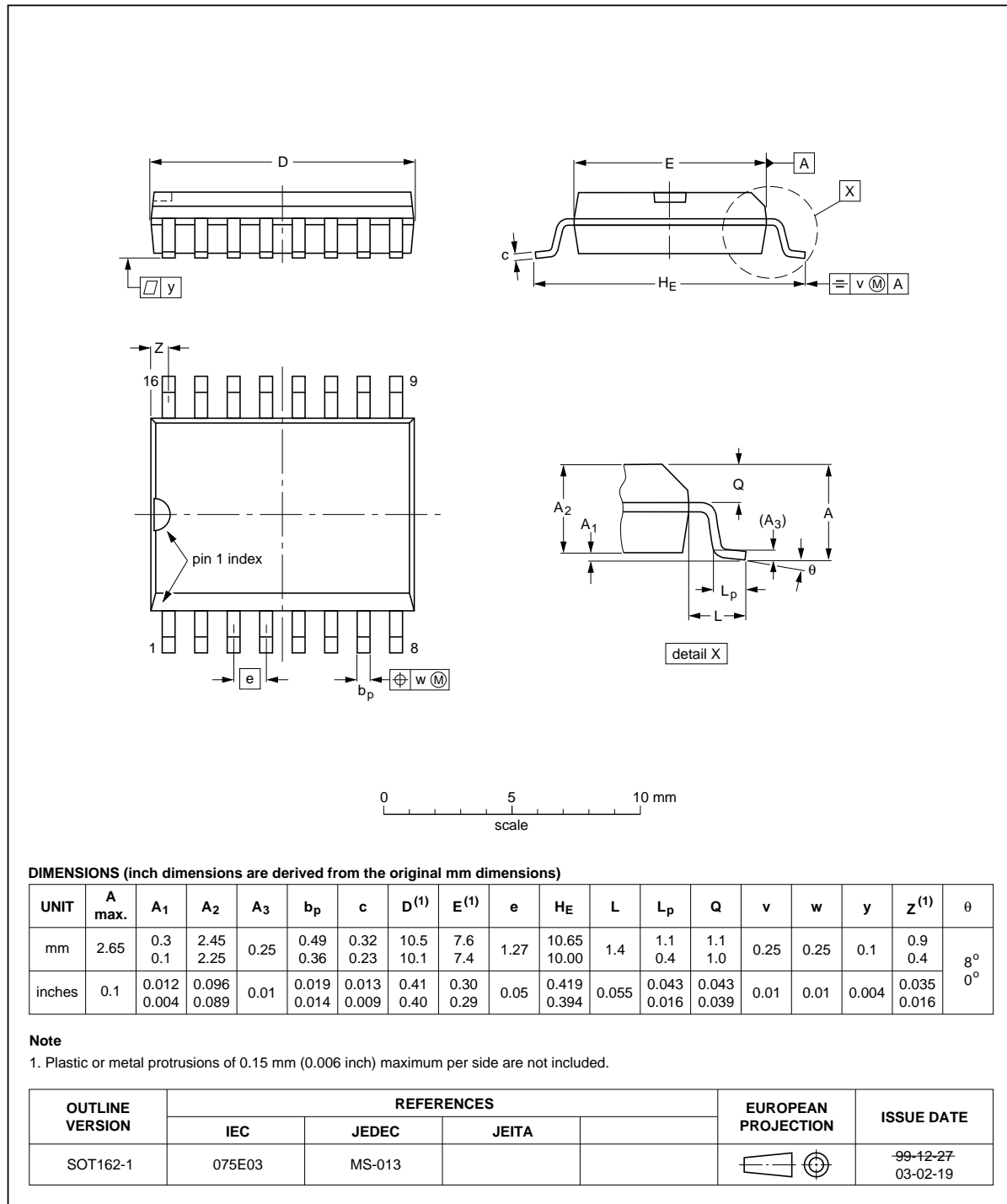

Fig 44. Package outline SOT162-1 (SO16) of PCA2129T

17. Packing information

17.1 Carrier tape information

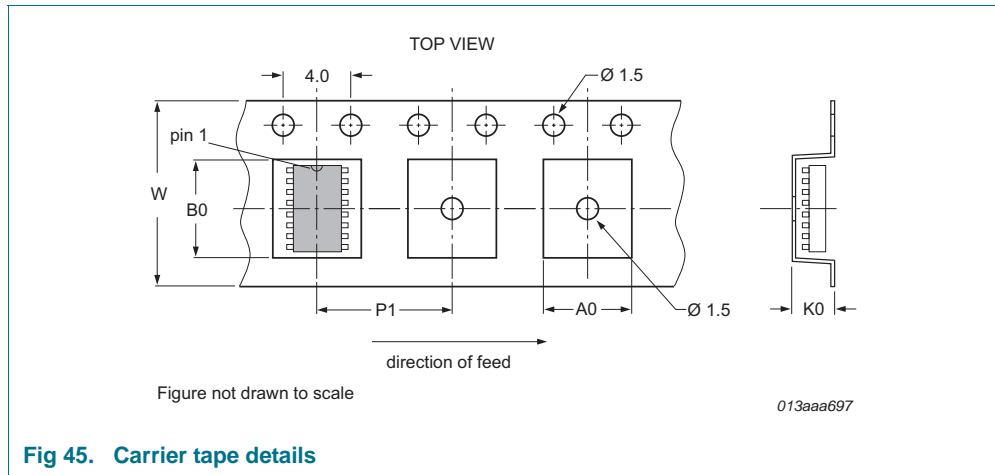

Fig 45. Carrier tape details

Table 57. Carrier tape dimensions

Symbol	Description	Value	Unit
A0	pocket width in x direction	10.6	mm
B0	pocket width in y direction	10.7	mm
K0	pocket height	3.3	mm
P1	sprocket hole pitch	12	mm
W	tape width in y direction	16	mm

18. Soldering

For information about soldering, see [Ref. 3 "AN11120"](#).

18.1 Footprint information

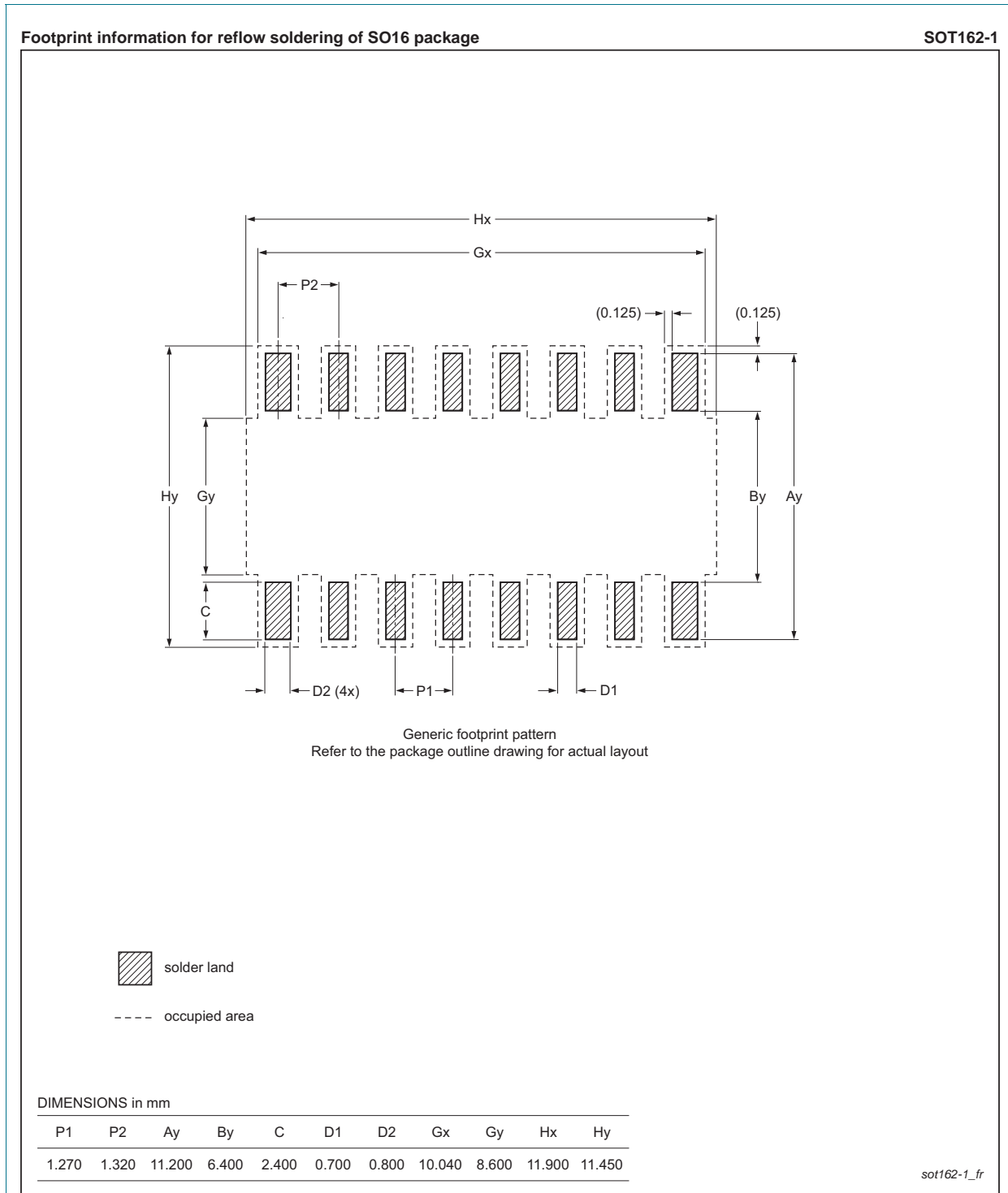

Fig 46. Footprint information for reflow soldering of SO16 package

19. Abbreviations

Table 58. Abbreviations

Acronym	Description
AEC	Automotive Electronics Council
AM	Ante Meridiem
BCD	Binary Coded Decimal
CDM	Charged Device Model
CMOS	Complementary Metal-Oxide Semiconductor
DC	Direct Current
GPS	Global Positioning System
HBM	Human Body Model
I ² C	Inter-Integrated Circuit
IC	Integrated Circuit
LSB	Least Significant Bit
MCU	Microcontroller Unit
MM	Machine Model
MSB	Most Significant Bit
PM	Post Meridiem
POR	Power-On Reset
PORO	Power-On Reset Override
PPM	Parts Per Million
RC	Resistance-Capacitance
RTC	Real Time Clock
SCL	Serial CLock line
SDA	Serial DATa line
SPI	Serial Peripheral Interface
SRAM	Static Random Access Memory
TCXO	Temperature Compensated Xtal Oscillator
Xtal	crystal

20. References

- [1] **AN10365** — Surface mount reflow soldering description
- [2] **AN10853** — Handling precautions of ESD sensitive devices
- [3] **AN11120** — Application and soldering information for the PCA2129 automotive TCXO RTC
- [4] **IEC 60134** — Rating systems for electronic tubes and valves and analogous semiconductor devices
- [5] **IEC 61340-5** — Protection of electronic devices from electrostatic phenomena
- [6] **IPC/JEDEC J-STD-020D** — Moisture/Reflow Sensitivity Classification for Nonhermetic Solid State Surface Mount Devices
- [7] **JESD22-A114** — Electrostatic Discharge (ESD) Sensitivity Testing Human Body Model (HBM)
- [8] **JESD22-C101** — Field-Induced Charged-Device Model Test Method for Electrostatic-Discharge-Withstand Thresholds of Microelectronic Components
- [9] **JESD78** — IC Latch-Up Test
- [10] **JESD625-A** — Requirements for Handling Electrostatic-Discharge-Sensitive (ESDS) Devices
- [11] **UM10204** — I²C-bus specification and user manual
- [12] **UM10569** — Store and transport requirements

21. Revision history

Table 59. Revision history

Document ID	Release date	Data sheet status	Change notice	Supersedes
PCA2129T v.3	20130124	Product data sheet	-	PCA2129T v.2.1
Modifications:	<ul style="list-style-type: none"> • Improved description of V_{BAT} pin in Table 4 			
PCA2129T v.2.1	20121114	Product data sheet	-	PCA2129T v.2
PCA2129T v.2	20121113	Product data sheet	-	PCA2129T v.1
PCA2129T v.1	20111027	Objective data sheet	-	-

22. Legal information

22.1 Data sheet status

Document status ^{[1][2]}	Product status ^[3]	Definition
Objective [short] data sheet	Development	This document contains data from the objective specification for product development.
Preliminary [short] data sheet	Qualification	This document contains data from the preliminary specification.
Product [short] data sheet	Production	This document contains the product specification.

[1] Please consult the most recently issued document before initiating or completing a design.

[2] The term 'short data sheet' is explained in section "Definitions".

[3] The product status of device(s) described in this document may have changed since this document was published and may differ in case of multiple devices. The latest product status information is available on the Internet at URL <http://www.nxp.com>.

22.2 Definitions

Draft — The document is a draft version only. The content is still under internal review and subject to formal approval, which may result in modifications or additions. NXP Semiconductors does not give any representations or warranties as to the accuracy or completeness of information included herein and shall have no liability for the consequences of use of such information.

Short data sheet — A short data sheet is an extract from a full data sheet with the same product type number(s) and title. A short data sheet is intended for quick reference only and should not be relied upon to contain detailed and full information. For detailed and full information see the relevant full data sheet, which is available on request via the local NXP Semiconductors sales office. In case of any inconsistency or conflict with the short data sheet, the full data sheet shall prevail.

Product specification — The information and data provided in a Product data sheet shall define the specification of the product as agreed between NXP Semiconductors and its customer, unless NXP Semiconductors and customer have explicitly agreed otherwise in writing. In no event however, shall an agreement be valid in which the NXP Semiconductors product is deemed to offer functions and qualities beyond those described in the Product data sheet.

22.3 Disclaimers

Limited warranty and liability — Information in this document is believed to be accurate and reliable. However, NXP Semiconductors does not give any representations or warranties, expressed or implied, as to the accuracy or completeness of such information and shall have no liability for the consequences of use of such information. NXP Semiconductors takes no responsibility for the content in this document if provided by an information source outside of NXP Semiconductors.

In no event shall NXP Semiconductors be liable for any indirect, incidental, punitive, special or consequential damages (including - without limitation - lost profits, lost savings, business interruption, costs related to the removal or replacement of any products or rework charges) whether or not such damages are based on tort (including negligence), warranty, breach of contract or any other legal theory.

Notwithstanding any damages that customer might incur for any reason whatsoever, NXP Semiconductors' aggregate and cumulative liability towards customer for the products described herein shall be limited in accordance with the *Terms and conditions of commercial sale* of NXP Semiconductors.

Right to make changes — NXP Semiconductors reserves the right to make changes to information published in this document, including without limitation specifications and product descriptions, at any time and without notice. This document supersedes and replaces all information supplied prior to the publication hereof.

Suitability for use in automotive applications — This NXP Semiconductors product has been qualified for use in automotive applications. Unless otherwise agreed in writing, the product is not designed, authorized or warranted to be suitable for use in life support, life-critical or safety-critical systems or equipment, nor in applications where failure or malfunction of an NXP Semiconductors product can reasonably be expected to result in personal injury, death or severe property or environmental damage. NXP Semiconductors and its suppliers accept no liability for inclusion and/or use of NXP Semiconductors products in such equipment or applications and therefore such inclusion and/or use is at the customer's own risk.

Applications — Applications that are described herein for any of these products are for illustrative purposes only. NXP Semiconductors makes no representation or warranty that such applications will be suitable for the specified use without further testing or modification.

Customers are responsible for the design and operation of their applications and products using NXP Semiconductors products, and NXP Semiconductors accepts no liability for any assistance with applications or customer product design. It is customer's sole responsibility to determine whether the NXP Semiconductors product is suitable and fit for the customer's applications and products planned, as well as for the planned application and use of customer's third party customer(s). Customers should provide appropriate design and operating safeguards to minimize the risks associated with their applications and products.

NXP Semiconductors does not accept any liability related to any default, damage, costs or problem which is based on any weakness or default in the customer's applications or products, or the application or use by customer's third party customer(s). Customer is responsible for doing all necessary testing for the customer's applications and products using NXP Semiconductors products in order to avoid a default of the applications and the products or of the application or use by customer's third party customer(s). NXP does not accept any liability in this respect.

Limiting values — Stress above one or more limiting values (as defined in the Absolute Maximum Ratings System of IEC 60134) will cause permanent damage to the device. Limiting values are stress ratings only and (proper) operation of the device at these or any other conditions above those given in the Recommended operating conditions section (if present) or the Characteristics sections of this document is not warranted. Constant or repeated exposure to limiting values will permanently and irreversibly affect the quality and reliability of the device.

Terms and conditions of commercial sale — NXP Semiconductors products are sold subject to the general terms and conditions of commercial sale, as published at <http://www.nxp.com/profile/terms>, unless otherwise agreed in a valid written individual agreement. In case an individual agreement is concluded only the terms and conditions of the respective agreement shall apply. NXP Semiconductors hereby expressly objects to applying the customer's general terms and conditions with regard to the purchase of NXP Semiconductors products by customer.

No offer to sell or license — Nothing in this document may be interpreted or construed as an offer to sell products that is open for acceptance or the grant, conveyance or implication of any license under any copyrights, patents or other industrial or intellectual property rights.

Export control — This document as well as the item(s) described herein may be subject to export control regulations. Export might require a prior authorization from competent authorities.

Translations — A non-English (translated) version of a document is for reference only. The English version shall prevail in case of any discrepancy between the translated and English versions.

22.4 Trademarks

Notice: All referenced brands, product names, service names and trademarks are the property of their respective owners.

I²C-bus — logo is a trademark of NXP B.V.

23. Contact information

For more information, please visit: <http://www.nxp.com>

For sales office addresses, please send an email to: salesaddresses@nxp.com

24. Tables

Table 1.	Ordering information	2	Table 38.	Timestamp_ctl - timestamp control register (address 12h) bit description	35
Table 2.	Ordering options	2	Table 39.	Sec_timestamp - second timestamp register (address 13h) bit description	35
Table 3.	Marking codes	2	Table 40.	Min_timestamp - minute timestamp register (address 14h) bit description	35
Table 4.	Pin description of PCA2129T	4	Table 41.	Hour_timestamp - hour timestamp register (address 15h) bit description	36
Table 5.	Register overview	7	Table 42.	Day_timestamp - day timestamp register (address 16h) bit description	36
Table 6.	Control_1 - control and status register 1 (address 00h) bit description	9	Table 43.	Mon_timestamp - month timestamp register (address 17h) bit description	36
Table 7.	Control_2 - control and status register 2 (address 01h) bit description	10	Table 44.	Year_timestamp - year timestamp register (address 18h) bit description	36
Table 8.	Control_3 - control and status register 3 (address 02h) bit description	11	Table 45.	Battery switch-over and timestamp	37
Table 9.	CLKOUT_ctl - CLKOUT control register (address 0Fh) bit description	12	Table 46.	Effect of bits MI and SI on pin INT and bit MSF	39
Table 10.	Temperature measurement period	12	Table 47.	First increment of time circuits after stop release	43
Table 11.	CLKOUT frequency selection	13	Table 48.	Interface selection input pin IFS	45
Table 12.	Aging_offset - crystal aging offset register (address 19h) bit description	14	Table 49.	Serial interface	46
Table 13.	Frequency correction at 25 °C, typical	14	Table 50.	Command byte definition	47
Table 14.	Power management control bit description	15	Table 51.	I ² C slave address byte	50
Table 15.	Output pin BBS	18	Table 52.	Limiting values	52
Table 16.	Seconds - seconds and clock integrity register (address 03h) bit description	23	Table 53.	Static characteristics	53
Table 17.	Seconds coded in BCD format	23	Table 54.	Frequency characteristics	57
Table 18.	Minutes - minutes register (address 04h) bit description	23	Table 55.	SPI-bus characteristics	58
Table 19.	Hours - hours register (address 05h) bit description	24	Table 56.	I ² C-bus characteristics	60
Table 20.	Days - days register (address 06h) bit description	24	Table 57.	Carrier tape dimensions	63
Table 21.	Weekdays - weekdays register (address 07h) bit description	24	Table 58.	Abbreviations	65
Table 22.	Weekday assignments	24	Table 59.	Revision history	66
Table 23.	Months - months register (address 08h) bit description	25			
Table 24.	Month assignments in BCD format	25			
Table 25.	Years - years register (address 09h) bit description	25			
Table 26.	Second_alarm - second alarm register (address 0Ah) bit description	27			
Table 27.	Minute_alarm - minute alarm register (address 0Bh) bit description	28			
Table 28.	Hour_alarm - hour alarm register (address 0Ch) bit description	28			
Table 29.	Day_alarm - day alarm register (address 0Dh) bit description	28			
Table 30.	Weekday_alarm - weekday alarm register (address 0Eh) bit description	29			
Table 31.	Watchdg_tim_ctl - watchdog timer control register (address 10h) bit description	30			
Table 32.	Watchdg_tim_val - watchdog timer value register (address 11h) bit description	30			
Table 33.	Programmable watchdog timer	31			
Table 34.	Flag location in register Control_2	32			
Table 35.	Example values in register Control_2	33			
Table 36.	Example to clear only AF (bit 4)	33			
Table 37.	Example to clear only MSF (bit 7)	33			

25. Figures

Fig 1.	Block diagram of PCA2129T	3		
Fig 2.	Pin configuration for PCA2129T (SO16)	4		
Fig 3.	Handling address registers	5		
Fig 4.	Battery switch-over behavior in standard mode with bit BIE set logic 1 (enabled)	16		
Fig 5.	Battery switch-over behavior in direct switching mode with bit BIE set logic 1 (enabled)	17		
Fig 6.	Battery switch-over circuit, simplified block diagram	18		
Fig 7.	Typical driving capability of V_{BBS} : ($V_{BBS} - V_{DD}$) with respect to the output load current I_{BBS}	18		
Fig 8.	Battery low detection behavior with bit BLIE set logic 1 (enabled)	19		
Fig 9.	Power failure event due to battery discharge: reset occurs	20		
Fig 10.	Dependency between POR and oscillator	21		
Fig 11.	Power-On Reset (POR) system	21		
Fig 12.	Power-On Reset Override (PORO) sequence, valid for both I ² C-bus and SPI-bus	22		
Fig 13.	Data flow of the time function	26		
Fig 14.	Access time for read/write operations	26		
Fig 15.	Alarm function block diagram	27		
Fig 16.	Alarm flag timing diagram	29		
Fig 17.	WD_CD set logic 1: watchdog activates an interrupt when timed out	32		
Fig 18.	Timestamp detection with two push-buttons on the TS pin (for example, for tamper detection)	34		
Fig 19.	Interrupt block diagram	38		
Fig 20.	\overline{INT} example for SI and MI when TI_TP is logic 1	39		
Fig 21.	INT example for SI and MI when TI_TP is logic 0	40		
Fig 22.	Example of shortening the \overline{INT} pulse by clearing the MSF flag	40		
Fig 23.	AF timing diagram	41		
Fig 24.	STOP bit functional diagram	44		
Fig 25.	STOP bit release timing	44		
Fig 26.	Interface selection	45		
Fig 27.	SDI, SDO configurations	46		
Fig 28.	Data transfer overview	46		
Fig 29.	SPI-bus write example	47		
Fig 30.	SPI-bus read example	47		
Fig 31.	Bit transfer	48		
Fig 32.	Definition of START and STOP conditions	48		
Fig 33.	System configuration	49		
Fig 34.	Acknowledgement on the I ² C-bus	49		
Fig 35.	Bus protocol, writing to registers	50		
Fig 36.	Bus protocol, reading from registers	50		
Fig 37.	Device diode protection diagram of PCA2129T	51		
Fig 38.	I_{OL} on pin SDA/ \overline{CE}	55		
Fig 39.	I_{DD} as a function of temperature	55		
Fig 40.	I_{DD} as a function of V_{DD}	56		
Fig 41.	Typical characteristic of frequency with respect to temperature	57		
Fig 42.	SPI-bus timing	59		
Fig 43.	I ² C-bus timing diagram; rise and fall times refer to 30 % and 70 %	61		
Fig 44.	Package outline SOT162-1 (SO16) of PCA2129T	62		
Fig 45.	Carrier tape details	63		
Fig 46.	Footprint information for reflow soldering of SO16 package	64		

26. Contents

1	General description	1	8.9.2	Register Minute_alarm	28
2	Features and benefits	1	8.9.3	Register Hour_alarm	28
3	Applications	2	8.9.4	Register Day_alarm	28
4	Ordering information	2	8.9.5	Register Weekday_alarm	29
4.1	Ordering options	2	8.9.6	Alarm flag	29
5	Marking	2	8.10	Timer functions	30
6	Block diagram	3	8.10.1	Register Watchdg_tim_ctl	30
7	Pinning information	4	8.10.2	Register Watchdg_tim_val	30
7.1	Pinning	4	8.10.3	Watchdog timer function	31
7.2	Pin description	4	8.10.4	Pre-defined timers: second and minute interrupt	32
8	Functional description	5	8.10.5	Clearing flags	32
8.1	Register overview	5	8.11	Timestamp function	34
8.2	Control registers	9	8.11.1	Timestamp flag	34
8.2.1	Register Control_1	9	8.11.2	Timestamp mode	35
8.2.2	Register Control_2	10	8.11.3	Timestamp registers	35
8.2.3	Register Control_3	11	8.11.3.1	Register Timestp_ctl	35
8.3	Register CLKOUT_ctl	12	8.11.3.2	Register Sec_timestp	35
8.3.1	Temperature compensated crystal oscillator	12	8.11.3.3	Register Min_timestp	35
8.3.1.1	Temperature measurement	12	8.11.3.4	Register Hour_timestp	36
8.3.2	Clock output	12	8.11.3.5	Register Day_timestp	36
8.4	Register Aging_offset	14	8.11.3.6	Register Mon_timestp	36
8.4.1	Crystal aging correction	14	8.11.3.7	Register Year_timestp	36
8.5	Power management functions	15	8.11.4	Dependency between Battery switch-over and timestamp	37
8.5.1	Battery switch-over function	15	8.12	Interrupt output, INT	38
8.5.1.1	Standard mode	16	8.12.1	Minute and second interrupts	39
8.5.1.2	Direct switching mode	16	8.12.2	INT pulse shortening	40
8.5.1.3	Battery switch-over disabled: only one power supply (V _{DD})	17	8.12.3	Watchdog timer interrupts	40
8.5.1.4	Battery switch-over architecture	17	8.12.4	Alarm interrupts	41
8.5.2	Battery backup supply	18	8.12.5	Timestamp interrupts	41
8.5.3	Battery low detection function	19	8.12.6	Battery switch-over interrupts	41
8.6	Oscillator stop detection function	20	8.12.7	Battery low detection interrupts	41
8.7	Reset function	21	8.13	External clock test mode	42
8.7.1	Power-On Reset (POR)	21	8.14	STOP bit function	43
8.7.2	Power-On Reset Override (PORO)	21	9	Interfaces	45
8.8	Time and date function	23	9.1	SPI-bus interface	46
8.8.1	Register Seconds	23	9.1.1	Data transmission	46
8.8.2	Register Minutes	23	9.2	I ² C-bus interface	48
8.8.3	Register Hours	24	9.2.1	Bit transfer	48
8.8.4	Register Days	24	9.2.2	START and STOP conditions	48
8.8.5	Register Weekdays	24	9.2.3	System configuration	48
8.8.6	Register Months	25	9.2.4	Acknowledge	49
8.8.7	Register Years	25	9.2.5	I ² C-bus protocol	49
8.8.8	Setting and reading the time	25	10	Internal circuitry	51
8.9	Alarm function	27	11	Limiting values	52
8.9.1	Register Second_alarm	27	12	Static characteristics	53

continued >>

12.1	Current consumption characteristics, typical .	55
12.2	Frequency characteristics	57
13	Dynamic characteristics	58
13.1	SPI-bus timing characteristics	58
13.2	I ² C-bus timing characteristics	60
14	Application information.	61
15	Test information.	61
15.1	Quality information	61
16	Package outline	62
17	Packing information	63
17.1	Carrier tape information	63
18	Soldering	63
18.1	Footprint information.	64
19	Abbreviations.	65
20	References	66
21	Revision history.	66
22	Legal information.	67
22.1	Data sheet status	67
22.2	Definitions	67
22.3	Disclaimers	67
22.4	Trademarks	68
23	Contact information.	68
24	Tables	69
25	Figures	70
26	Contents	71

Please be aware that important notices concerning this document and the product(s) described herein, have been included in section 'Legal information'.

© NXP B.V. 2013.

All rights reserved.

For more information, please visit: <http://www.nxp.com>

For sales office addresses, please send an email to: salesaddresses@nxp.com

Date of release: 24 January 2013

Document identifier: PCA2129T