

**PART NO. : TG41-2006NRL**

16PIN SMT ISOLATION MODULE  
 MEET REQUIREMENTS OF CS8904-CM3  
 10BASE-T FILTERLESS SOLUTION  
 LEAD-FREE/ROHS COMPLIANT  
 COMPATIBLE TO LEAD-FREE SOLDERING PROCESS  
 CONDITION PER IPC/JEDEC J-STD-020C  
 OPERATING TEMPERATURE -40/+85°C

**ELECTRICAL SPECIFICATIONS @25° C**

TURNS RATIO		
P1-3:P16-14		1CT:1CT ±3%
P6-8:P11-9		1CT:2.5CT ±3%
OCL P1-3		200µH min
P6-8		35µH min
DCR P1-3		0.5Ω max
P6-8		0.3Ω max
Cw/w		15pF max
LL P1-3		0.4µH max
P6-8		0.1µH max
CMR 1-30MHz		-50dB typ
40-100MHz		-40dB typ
ISOLATION		1500Vrms

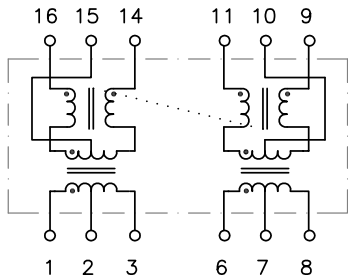
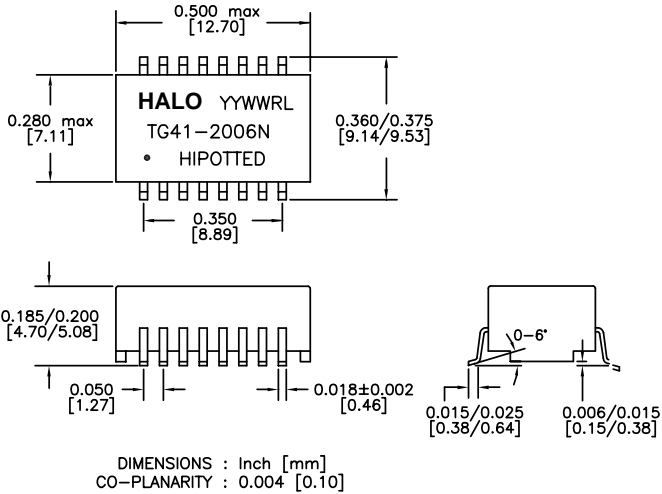

<b>HALO/PBL</b>	TITLE	10BASE-T ISOLATION MODULE		SIGNATURES	DATE	REV.	DESC.	DATE
	FOR	CS8904-CM3		DRAWN	PETER LU	2/1/05	A	
	PART NO.	TG41-2006NRL		CHECKED				
	SCALE	NONE	PAGE	1 OF 1	APPROVED			
CALIFORNIA, USA KOWLOON, HONG KONG SINGAPORE				FILE	TG41NRL.DWG			