

USS-820D USB Device Controller



Features

- Full compliance with the *Universal Serial Bus Specification Revision 1.1*.
- Backward compatible with USS-820B and USS-820C revisions.
- Self-powered or bus-powered USB device. Meets USB power specifications for bus-powered devices.
- Full-speed USB device (12 Mbits/s).
- USB device controller with protocol control and administration for up to 16 USB endpoints.
- Supports control, interrupt, bulk, and isochronous transfers for all 16 endpoints.
- Programmable endpoint types and FIFO sizes and internal 1120-byte logical (2240-byte physical for dual-packet mode) shared FIFO storage allow a wide variety of configurations.
- Dual-packet mode of FIFOs reduces latency.
- Supports USB remote wake-up feature.
- On-chip crystal oscillator allows external 12 MHz crystal or 3 V/5 V clock source.
- On-chip analog PLL creates 48 MHz clock from internal 12 MHz clock.
- Integrated USB transceivers.
- 5 V tolerant I/O buffers allow operation in 3 V or 5 V system environments for 0 °C to 70 °C temperature range.
- 5 V tolerant I/O buffers allow operation in 3 V only system environments for -20 °C to +85 °C temperature range.
- Implemented in Agere Systems Inc. 0.25 μm, 3 V standard-cell library.
- 44-pin MQFP (USS-820D).
- 48-pin TQFP (USS-820TD).
- Evaluation kit available.

New Features After Revision B

- New, centralized FIFO status bits and interrupt output pin reduce firmware load.
- New, additional nonisochronous transmit mode allows NAK response to cause interrupt.
- Isochronous behavior enhancements simplify firmware control.
- Additional FIFO sizes for nonisochronous endpoints.
- USB reset can be programmed to clear device address.
- USB reset output status pin.
- Firmware ability to wake up and reset a suspended device.
- Lower power.
- 5 V supply no longer required for 5 V tolerant operation.

Applications

- Suitable for peripherals with embedded microprocessors.
- Glueless interface to microprocessor buses.
- Support of multifunction USB implementations, such as printer/scanner and integrated multimedia applications.
- Suitable for a broad range of device class peripherals in the USB standard.

Table of Contents

Contents	Page
Features	1
New Features After Revision B	1
Applications	1
Description.....	3
Serial Interface Engine.....	3
Protocol Layer.....	4
FIFO Control	4
FIFO Programmability.....	4
FIFO Access	4
Transmit FIFO	5
Receive FIFO	6
Pin Information	7
Register Timing Characteristics.....	9
Register Interface	12
Special Firmware Action for Shared Register Bits	14
Register Reads with Side Effects.....	15
Register Descriptions	16
Interrupts	41
Firmware Responsibilities for USB SETUP Commands.....	42
Other Firmware Responsibilities.....	43
Frame Timer Behavior.....	43
Suspend and Resume Behavior.....	43
Hardware Suspend Detect.....	44
Firmware Suspend Initiate	44
Hardware Resume Detect/Initiate	45
Hardware Resume Sequence	45
Firmware Resume Sequence	45
Special Suspend Considerations for Bus-Powered Devices	45
Application Notes.....	47
Absolute Maximum Ratings.....	47
Electrical Characteristics	48
dc Characteristics	48
Power Considerations	49
USB Transceiver Driver Characteristics	49
Connection Requirements	50
USB Transceiver Connection.....	50
Oscillator Connection Requirements.....	51
Outline Diagrams.....	52
44-Pin MQFP (USS-820D).....	52
48-Pin TQFP (USS-820TD)	53
Ordering Information.....	53
Appendix A. Special Function Register Bit Names.....	54
Appendix B. USS-820D Register Map.....	55
Appendix C. Changes from USS-820/USS-825 Revision B to C	56
Appendix D. Changes from USS-820/USS-820T Revision C to D	57

Description

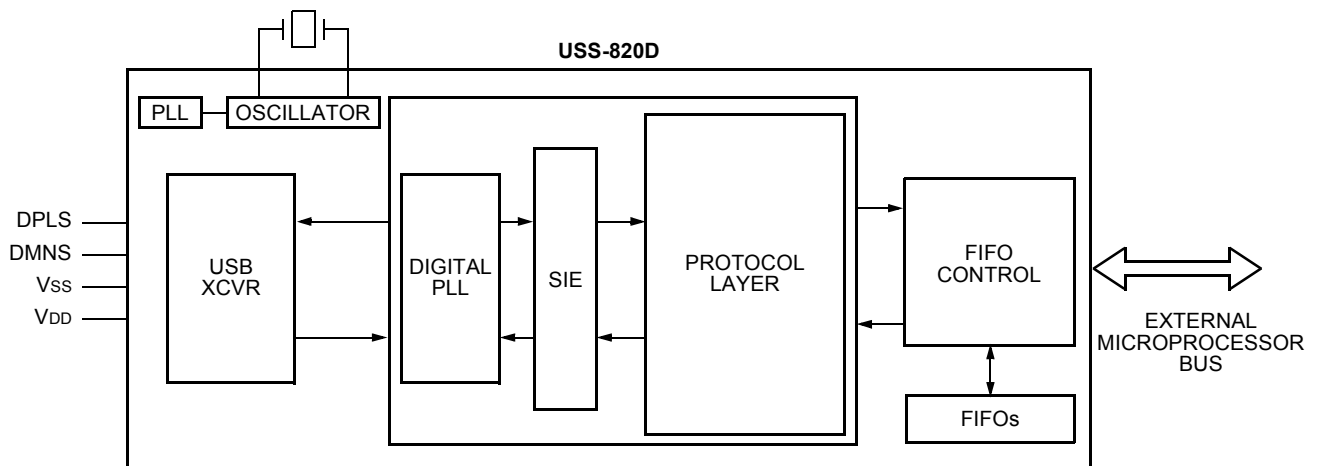

5-8121

Figure 1. Block Diagram

USS-820D is a USB device controller that provides a programmable bridge between the USB and a local microprocessor bus. It is available in two package types: 44-pin MQFP (USS-820D) and 48-pin TQFP (USS-820TD, formerly USS-825). The USS-820D allows PC peripherals to upgrade to USB connectivity without major redesign effort. It is programmable through a simple read/write register interface that is compatible with industry-standard USB microcontrollers.

USS-820D is designed in 100% compliance with the USB industry standard, allowing device-side USB products to be reliably installed using low-cost, off-the-shelf cables and connectors.

The integrated USB transceiver supports 12 Mbits/s full-speed operation. FIFO options support all four transfer types: control, interrupt, bulk, and isochronous, as described in *Universal Serial Bus Specification Revision 1.1*, with a wide range of packet sizes. Its double sets of FIFO enable the dual-packet mode feature. The dual-packet mode feature reduces latency by allowing simultaneous transfers on the host and microprocessor sides of a given unidirectional endpoint.

The USS-820D supports a maximum of eight bidirectional endpoints with 16 FIFOs (eight for transmit and eight for receive) associated with them. The FIFOs are on-chip, and sizes are programmable up to a total of 1120 logical bytes. When the dual-packet mode feature is enabled, the device uses a maximum of 2240 bytes of physical storage. This additional physical FIFO storage is managed by the device hardware and is transparent to the user.

Agere Systems Inc.

The FIFO sizes supported are 8 bytes, 16 bytes, 32 bytes, and 64 bytes for nonisochronous pipes, and 64 bytes, 256 bytes, 512 bytes, and 1024 bytes for isochronous pipes. The FIFO size of a given endpoint defines the upper limit to maximum packet size that the hardware can support for that endpoint. This flexibility covers a wide range of data rates, data types, and combinations of applications.

The USS-820D can be clocked either by connecting a 12 MHz crystal to the XTAL1 and XTAL2 pins, or by using a 12 MHz external oscillator. The internal 12 MHz clock period, which is a function of either of these clock sources, is referred to as the device clock period (tCLK) throughout this data sheet.

Serial Interface Engine

The SIE is the USB protocol interpreter. It serves as a communicator between the USS-820D and the host through the USB lines.

The SIE functions include the following:

- Package protocol sequencing.
- SOP (start of packet), EOP (end of packet), RESUME, and RESET signal detection and generation.
- NRZI data encoding/decoding and bit stuffing.
- CRC generation and checking for token and data.
- Serial-to-parallel and parallel-to-serial data conversion.

Description (continued)

Protocol Layer

The protocol layer manages the interface between the SIE and FIFO control blocks. It passes all USB OUT and SETUP packets through to the appropriate FIFO. It is the responsibility of firmware to correctly interpret and execute each USB SETUP command (as documented in the Firmware Responsibilities for USB SETUP Commands section) via the register interface. The protocol layer tracks the setup, data, and status stages of control transfers.

FIFO Control

USS-820D's FIFO control manager handles the data flow between the FIFOs and the device controller's protocol layer. It handles flow control and error handling/fault recovery to monitor transaction status and to relay control events via interrupt vectors.

FIFO Programmability

Table 1 shows the programmable FIFO sizes. The size of the FIFO determines the maximum packet size that the hardware can support for a given endpoint. An endpoint is only allocated space in the shared FIFO storage if its RXEPEN/TXEPEN bit = 1. If the endpoint is disabled (RXEPEN/TXEPEN = 0), it is allocated 0 bytes. Register changes that affect the allocation of the shared FIFO storage among endpoints must not be made while there is valid data present in any of the enabled endpoints' FIFOs. Any such changes will render all FIFO contents undefined. Register bits that affect the FIFO allocation are the endpoint enable bits (the TXEPEN and RXEPEN bits of EPCON), the size bits of an enabled endpoint (FFSZ bits of TXCON and RXCON), the isochronous bit of an enabled endpoint (TXISO bit of TXCON and RXISO bit of RXCON), and the FEAT bit of the MCSR register.

If the MCSR.FEAT register bit is set to 1, additional FIFO sizes are enabled for nonisochronous endpoints, as shown in Table 1.

Table 1. Programmable FIFO Sizes

FFSZ[1:0]	00	01	10	11
Nonisochronous	16 bytes	64 bytes	8 bytes*	32 bytes*
Isochronous	64 bytes	256 bytes	512 bytes	1024 bytes

* Assumes MCSR.FEAT = 1. If this bit is 0 and FFSZ = 10 or 11, both indicate a size of 64 bytes.

Each FIFO can be programmed independently via the TXCON and RXCON registers, but the total logical size of the enabled endpoints (TX FIFOs + RX FIFOs) must not exceed 1120 bytes. The 1120-byte total allows a configuration with a full-sized, 1024-byte isochronous endpoint, a minimum-sized, 64-byte isochronous feedback endpoint, and the required, bidirectional, 16-byte control endpoint. When the dual-packet mode feature is enabled, the device uses a maximum of 2240 bytes of physical storage. This additional physical FIFO storage is managed by the device hardware and is transparent to the user.

FIFO Access

The transmit and receive FIFOs are accessed by the application through the register interface (see Tables 22—25 for transmit FIFO registers and Tables 26—29 for receive FIFO registers).

The transmit FIFO is written to via the TXDAT register, and the receive FIFO is read via the RXDAT register. The particular transmit/receive FIFO is specified by the EPINDEX register. Each FIFO is accessed serially, each RXDAT read increments the receive FIFO read pointer by 1, and each TXDAT write increments the transmit FIFO write pointer by 1.

Each FIFO consists of two data sets to provide the capability for simultaneous read/write access. Control of these pairs of data sets is managed by the hardware, invisible to the application, although the application must be aware of the implications. The receive FIFO read access is advanced to the next data set by firmware setting the RXFFRC bit of RXCON. This bit clears itself after the advance is complete. The transmit FIFO write access is advanced to the next data set by firmware writing the byte count to the TXCNTH/L registers.

The USB access to the receive and transmit FIFOs is managed by the hardware, although the control of the nonisochronous data sets can be overridden by the ARM and ATM bits of RXCON and TXCON, respectively. A successful USB transaction causes FIFO access to be advanced to the next data set. A failed USB transaction (e.g., for receive operations, FIFO overrun, data time-out, CRC error, bit stuff error; for transmit operations, FIFO underrun, no ACK from host) causes the FIFO read/write pointer to be reversed to the beginning of the data set to allow transmission retry for nonisochronous transfers.

Description (continued)

FIFO Access (continued)

Transmit FIFO

The transmit FIFOs are circulating data buffers that have the following features:

- Support up to two separate data sets of variable sizes (dual-packet mode).
- Include byte counter register for storing the number of bytes in the data sets.
- Protect against overwriting data in a full FIFO.
- Can retransmit the current data set.

All transmit FIFOs use the same architecture (see Figure 2). The transmit FIFO and its associated logic can manage up to two data sets: data set 0 (ds0) and data set 1 (ds1). Since two data sets can be used in the FIFO, back-to-back transmissions are supported. Dual-packet mode for transmit FIFOs is enabled by default. Single-packet mode can be enforced by firmware convention (see TXFIF register bits).

The CPU writes to the FIFO location that is specified by the write pointer. After a write, the write pointer automatically increments by 1. The read marker points to the first byte of data written to a data set, and the read pointer points to the next FIFO location to be read by the USB interface. After a read, the read pointer automatically increments by 1.

When a good transmission is completed, the read marker can be advanced to the position of the read pointer to set up for reading the next data set. When a bad transmission is completed, the read pointer can be reversed to the position of the read marker to enable the function interface to reread the last data set for retransmission. The read marker advance and read pointer reversal can be achieved two ways: explicitly by firmware or automatically by hardware, as indicated by bits in the transmit FIFO control register (TXCON).

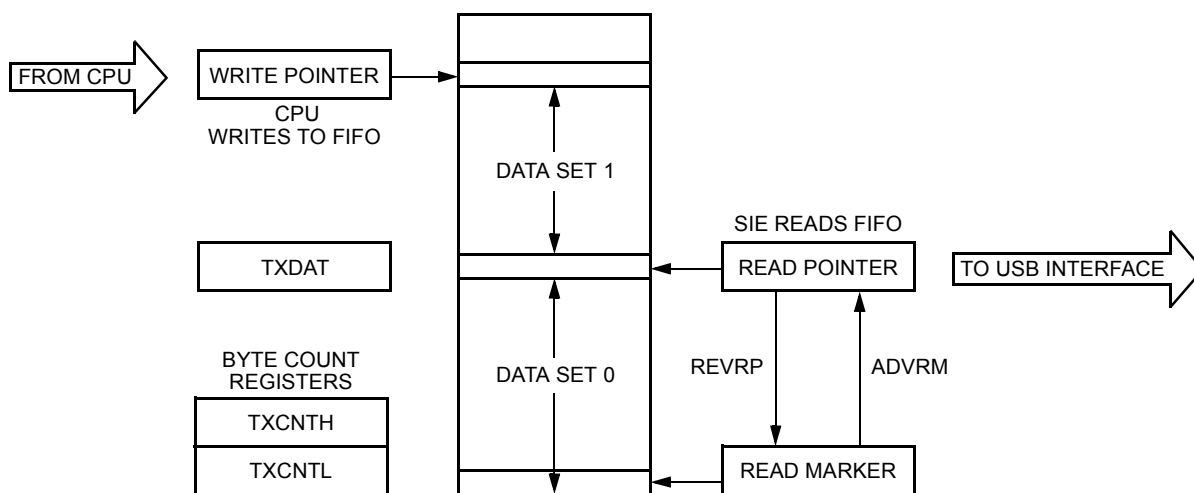

5-5206

Figure 2. Transmit FIFO

Description (continued)

FIFO Access (continued)

Receive FIFO

The receive FIFOs are circulating data buffers that have the following features:

- Support up to two separate data sets of variable sizes (dual-packet mode).
- Include byte count register that accesses the number of bytes in data sets.
- Include flags to signal a full FIFO and an empty FIFO.
- Can reread the last data set.

Figure 3 shows a receive FIFO. A receive FIFO and its associated logic can manage up to two data sets: data set 0 (ds0) and data set 1 (ds1). Since two data sets can be used in the FIFO, back-to-back transmissions are supported. Single-packet mode is established by default after a USS-820D device reset, which sets the RXSPM register bit. Firmware can enable dual-packet mode by clearing the RXSPM bit to 0.

The receive FIFO is symmetrical to the transmit FIFO in many ways. The SIE writes to the FIFO location specified by the write pointer. After a write, the write pointer automatically increments by 1. The write marker points to the first byte of data written to a data set, and the read pointer points to the next FIFO location to be read by the CPU. After a read, the read pointer automatically increments by 1.

When a good reception is completed, the write marker can be advanced to the position of the write pointer to set up for writing the next data set. When a bad transmission is completed, the write pointer can be reversed to the position of the write marker to enable the SIE to rewrite the last data set after receiving the data again. The write marker advance and write pointer reversal can be achieved two ways: explicitly by firmware or automatically by hardware, as specified by bits in the receive FIFO control register (RXCON).

The CPU should not read data from the receive FIFO before all bytes are received and successfully acknowledged because the reception may be bad.

To avoid overwriting data in the receive FIFO, the SIE monitors the FIFO full flag (RXFULL bit in RXFLG). To avoid reading a byte when the FIFO is empty, the CPU can monitor the FIFO empty flag (RXEMP bit in RXFLG).

The CPU must not change the value of the EPINDEX register during the process of reading a data set from a particular receive FIFO. Once the CPU has read the first byte of a data set, the processor must ensure that the EPINDEX register setting remains unchanged until after the last byte is read from that data set. Registers other than EPINDEX may be read or written during this period, except for registers which affect the overall FIFO configuration, as described in the FIFO Programmability section. If EPINDEX is allowed to change during a data set read, incorrect data will be returned by the USS-820D when subsequent bytes are read from the partially read data set. There is no such restriction when writing FIFOs.

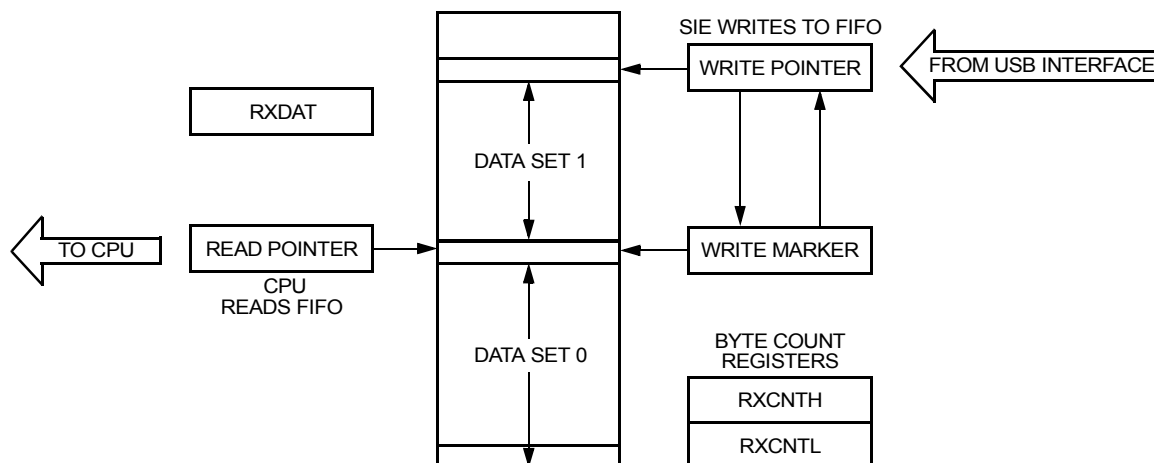
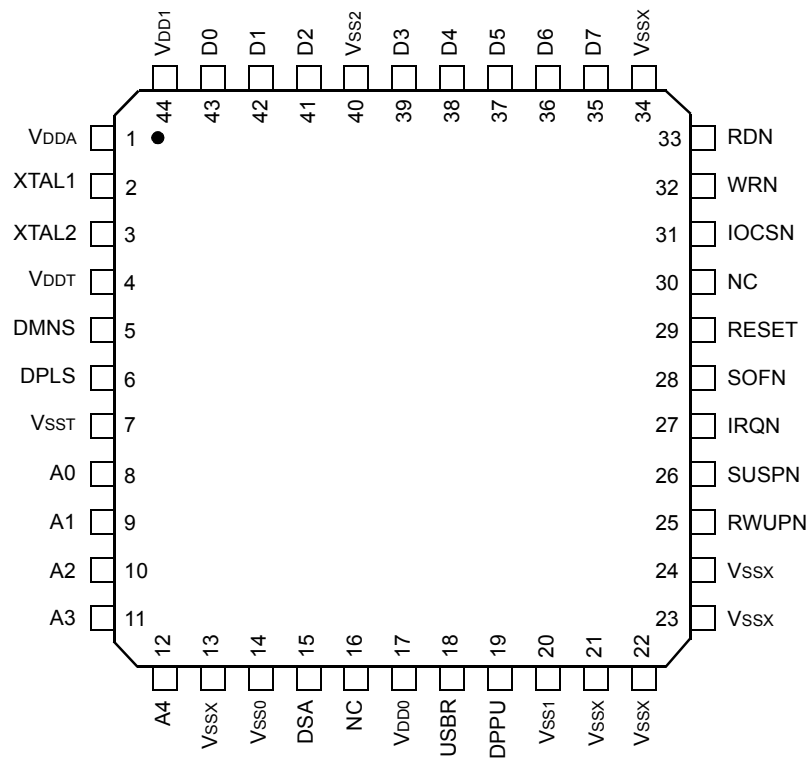

Figure 3. Receive FIFO

5-5207

Pin Information



5-8117

Figure 4. USS-820D Pin Diagram (44-Pin MQFP)

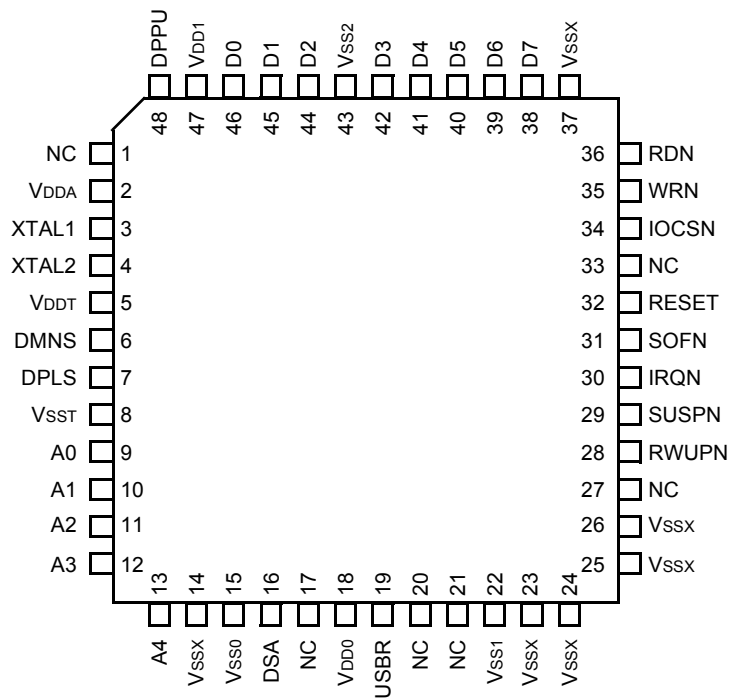

5-8118

Figure 5. USS-820D Pin Diagram (48-Pin TQFP)

Pin Information (continued)

Table 2. Pin Descriptions

44-Pin MQFP (USS-820D)	48-Pin TQFP (USS-820TD)	Symbol*	Type	Name/Description
1	2	VDDA	P	3.3 V Power Supply for Analog PLL.
2	3	XTAL1	I	Crystal/Clock Input. If the internal oscillator is used, this is the crystal input. If an external oscillator is used, this is the clock input.
3	4	XTAL2	O	Crystal/Clock Output. If the internal oscillator is used, this is the crystal output. If an external oscillator is used, this output should be left unconnected.
4	5	VDDT	P	3.3 V Power Supply for USB Transceiver.
5	6	DMNS	I/O	USB Differential Data Bus Minus.
6	7	DPLS	I/O	USB Differential Data Bus Plus.
7	8	VSST	P	Device Ground for USB Transceiver.
12, 11, 10, 9, 8	13, 12, 11, 10, 9	A[4:0]	I	Address Bus. This is the address bus for the controller to access the register set.
13	14	VSSX	P	Device Ground. For compatibility with USS-820 revision B, this pin can be connected to a controller address bit, as long as it is guaranteed to be equal to 0 during register accesses and meets all address pin timing requirements.
14, 20, 21, 22, 23, 24, 34, 40	15, 22, 23, 24, 25, 26, 37, 43	VSS0, VSS1, VSS2, VSSX	P	Device Ground.
15	16	DSA	O	Data Set Available. Indicates one or more receive data sets are valid, or one or more transmit data sets are empty (available). For compatibility with USS-820 revision B, this output is 3-stated if MCSR.BDFEAT = 0.
18	19	USBR	O	USB Reset Detected. Indicates a USB reset event has been detected on USB. This pin will remain asserted until the SSR.RESET register bit is cleared by firmware. For compatibility with USS-820 revision B, this output is 3-stated if MCSR.BDFEAT = 0.
16	1, 17, 20, 21, 27	NC†	—	No Connect.
17, 44	18, 47	VDD0, VDD1	P	3.3 V Power Supply.
19	48	DPPU	O	DPLS Pull-Up. Can be used to supply power to the DPLS 1.5 kΩ pull-up resistor to allow firmware to simulate a device physical disconnect. This pin is directly controlled by the DPEN register bit.
25	28	RWUPN	I	Remote Wake-Up (Active-Low). Device is initiating a remote wake-up from a suspend condition. This input is ignored if SCR register bit RWUPE = 0.
26	29	SUSPN	O	Suspend (Active-Low). USB suspend has been detected; chip has entered suspend (low power) mode. This pin is deasserted when a wake-up event is detected.

* Active-low signals within this document are indicated by an N following the symbol names.

† Pins marked as NC must have no external connections, except where noted.

Pin Information (continued)

Table 2. Pin Descriptions (continued)

44-Pin MQFP (USS-820D)	48-Pin TQFP (USS-820TD)	Symbol*	Type	Name/Description
27	30	IRQN	O	Interrupt (Programmable Active-Low or Active-High). An interrupt signal is sent to the controller whenever an event such as TX/RX done, SUSPEND, RESUME, USBRESET, or SOF occurs.
28	31	SOFN	O	Start of Frame (Active-Low). This signal is asserted low for eight tCLK periods when an SOF token is received.
29	32	RESET	I	Reset. When this signal is held high, all state machines and registers are set at the default state.
30	33	NC†	—	No Connect. For compatibility with the USS-820 revision B, this pin can be connected to a 3 V or 5 V supply with no harmful effect.
31	34	IOCSN	I	Chip Select (Active-Low).
32	35	WRN	I	Control Register Write (Active-Low).
33	36	RDN	I	Control Register Read (Active-Low).
35, 36, 37, 38, 39, 41, 42, 43	38, 39, 40, 41, 42, 44, 45, 46	D[7:0]	I/O	Data Bus.

* Active-low signals within this document are indicated by an N following the symbol names.

† Pins marked as NC must have no external connections, except where noted.

Register Timing Characteristics

All register timing specifications assume a 100 pF load on the D[7:0] package pins and a 70 pF load on all other package pins.

Table 3. Timing Parameters

Symbol	Parameter	Min	Max	Unit
tCLK	Internal Clock Period	—	83.3	ns
tRST	RESET Assert Time	500	—	ns

Register Timing Characteristics (continued)

Table 4. Register Access Timing—Special Function Register (SFR) Read

Symbol	Parameter	Min	Max	Unit
tRDASU	Read Address Setup Time (starts before the trailing edge of RDN or IOCSN, whichever is first)	60	—	ns
tRDAHD	Read Address Hold (starts after the trailing edge of RDN or IOCSN, whichever is first): Operational Suspended	-10 -1	— —	ns ns
tRDDV1, tRDDV2	Read Data Valid (from the leading edge of RDN or IOCSN or from address valid, whichever is last , to data valid): Operational Suspended	— —	74 33	ns ns
tRDDZ	Read Data to Z State (starts after the trailing edge of RDN or IOCSN, whichever is first)	2	32	ns
tRDREC	Recovery Time Between Reads (from the trailing edge of RDN or IOCSN, whichever is first , to the next leading edge of RDN or IOCSN, whichever is last)	23	—	ns
tRDRECRXD	Recovery Time Between Consecutive RXDAT Reads (from the trailing edge of RDN or IOCSN, whichever is first , to the next trailing edge of RDN or IOCSN, whichever is first)	86	—	ns
tRDPW	Minimum Pulse Width (from the leading edge of RDN or IOCSN, whichever is last , to the trailing edge of RDN or IOCSN, whichever is first)	23	—	ns

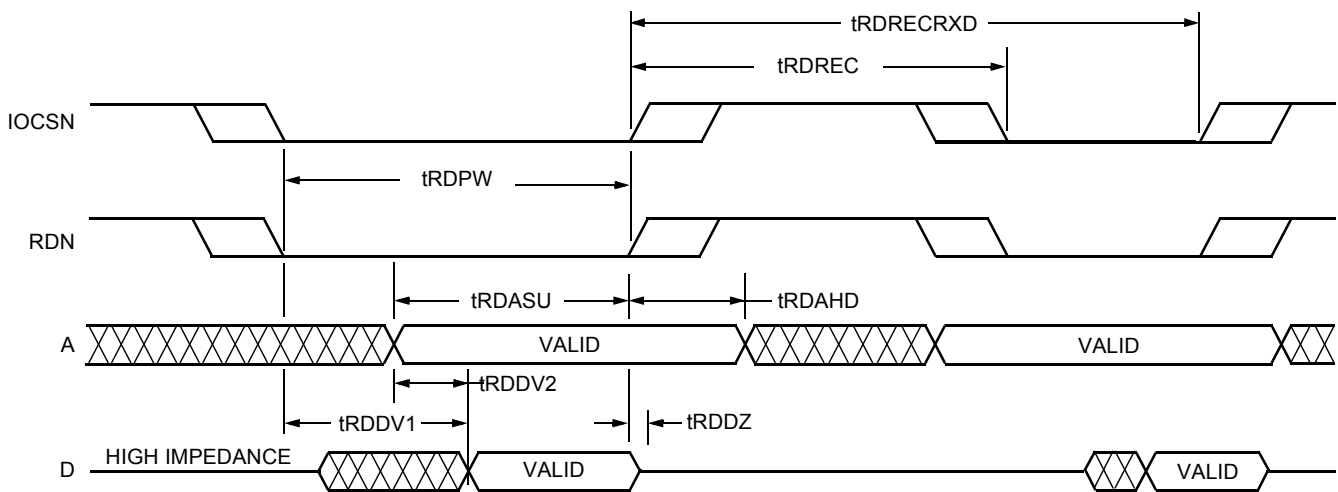

5-5352

Figure 6. Register Access Timing—SFR Read

Register Timing Characteristics (continued)

Table 5. Register Access Timing—Special Function Register (SFR) Write

Symbol	Parameter	Min	Unit
tWRASU	Write Address Setup Time (starts before the trailing edge of WRN or IOCSN, whichever is first)	60	ns
tWRAHD	Write Address Hold (starts after the trailing edge of WRN or IOCSN, whichever is first)	-10	ns
tWRPW	Write Minimum Pulse Width (from the leading edge of WRN or IOCSN, whichever is last , to the trailing edge of WRN or IOCSN, whichever is first)	23	ns
tWRDSU	Write Data Setup (from data valid to the trailing edge of WRN or IOCSN, whichever is first)	60	ns
tWRDHD	Write Data Hold (from the trailing edge of WRN or IOCSN, whichever is first , to data not valid)	-10	ns
tWRREC	Recovery Time Between Write Attempts (from the trailing edge of WRN or IOCSN, whichever is first , to the next leading edge of WRN or IOCSN, whichever is last)	23	ns
tWRRECC	Recovery Time Between Write Completes (from the trailing edge of WRN or IOCSN, whichever is first , to the next trailing edge of WRN or IOCSN, whichever is first)	86	ns

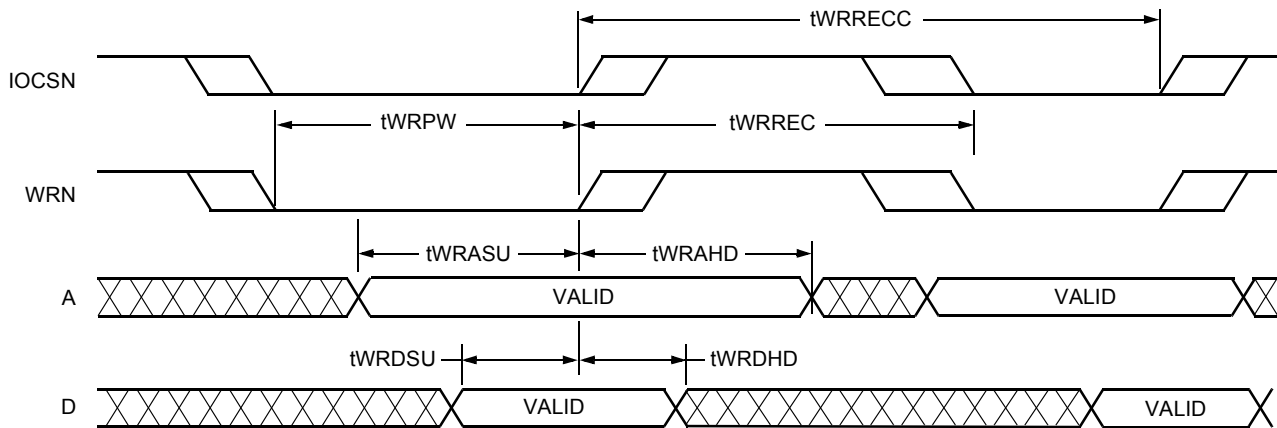

5-5353

Figure 7. Register Access Timing—SFR Write

Register Interface

The USS-820D is controlled through an asynchronous, read/write register interface. Registers are addressed via the A[4:0] pins, and control is provided through the RDN, WRN, and IOCSN pins. Reserved bits of registers must always be written with 0. Writing 1 to these bits may produce undefined results. These bits return undefined values when read.

A register read is accomplished by placing the register address on the A bus and asserting the IOCSN and RDN pins. After read data valid (tRDDV), the register data will appear on the D bus. A register write is accomplished by placing the register address on the A bus and the data to be written on the D bus, and asserting the IOCSN and WRN pins.

Tables 6 and 7 show alphabetical and numerical listings of all the available special function registers (SFR) for the USS-820D. For reference purposes, an alphabetized list of SFR bit names is included in Appendix A. Tables 11—38 provide details for each of the registers. Some of these registers are replicated for each endpoint. The individual, endpoint-specific register is selected by the EPINDEX register.

Table 6. Special Function Registers (By Name)

Register	Description	Address	Table	Page
DSAV	Data Set Available	1DH	37	40
DSAV1	Data Set Available 1	1EH	38	40
EPCON*	Endpoint Control Register	0BH [†]	18	21
EPINDEX	Endpoint Index Register	0AH	17	20
FADDR	Function Address Register	10H	21	26
LOCK	Suspend Power-Off Locking Register	19H	33	38
MCSR	Miscellaneous Control/Status Register	1CH	36	39
PEND	Pend Hardware Status Update Register	1AH	34	38
REV	Hardware Revision Register	18H	32	37
RXCNTH	Receive FIFO Byte-Count High Register	07H [†]	27	31
RXCNTL	Receive FIFO Byte-Count Low Register	06H [†]	27	31
RXCON	Receive FIFO Control Register	08H [†]	28	31
RXDAT	Receive FIFO Data Register	05H [†]	26	30
RXFLG	Receive FIFO Flag Register	09H [†]	29	33
RXSTAT*	Endpoint Receive Status Register	0DH [†]	20	24
SBI*	Serial Bus Interrupt Register	14H	13	17
SBI1*	Serial Bus Interrupt Register 1	15H	14	18
SBIE	Serial Bus Interrupt Enable Register	16H	11	16
SBIE1	Serial Bus Interrupt Enable Register 1	17H	12	16
SCR	System Control Register	11H	30	36
SCRATCH	Scratch Firmware Information Register	1BH	35	38
SOFH*	Start of Frame High Register	0FH	15	19
SOFL*	Start of Frame Low Register	0EH	16	20
SSR*	System Status Register	12H	31	37
TXCNTH	Transmit FIFO Byte-Count High Register	02H [†]	23	26
TXCNTL	Transmit FIFO Byte-Count Low Register	01H [†]	23	26
TXCON	USB Transmit FIFO Control Register	03H [†]	24	27
TXDAT	Transmit FIFO Data Register	00H [†]	22	26
TXFLG	Transmit FIFO Flag Register	04H [†]	25	28
TXSTAT	Endpoint Transmit Status Register	0CH [†]	19	22

* Contains shared bits. See Special Firmware Action for Shared Register Bits section.

† Indexed by EPINDEX.

Register Interface (continued)

Table 7. Special Function Registers (By Address)

Address	Register	Description	Table	Page
00H*	TXDAT	Transmit FIFO Data Register	22	26
01H*	TXCNTL	Transmit FIFO Byte-Count Low Register	23	26
02H*	TXCNTH	Transmit FIFO Byte-Count High Register	23	26
03H*	TXCON	USB Transmit FIFO Control Register	24	27
04H*	TXFLG	Transmit FIFO Flag Register	25	28
05H*	RXDAT	Receive FIFO Data Register	26	30
06H*	RXCNTL	Receive FIFO Byte-Count Low Register	27	31
07H*	RXCNTH	Receive FIFO Byte-Count High Register	27	31
08H*	RXCON	Receive FIFO Control Register	28	31
09H*	RXFLG	Receive FIFO Flag Register	29	33
0AH	EPINDEX	Endpoint Index Register	17	20
0BH*	EPCON†	Endpoint Control Register	18	21
0CH*	TXSTAT	Endpoint Transmit Status Register	19	22
0DH*	RXSTAT†	Endpoint Receive Status Register	20	24
0EH	SOFL†	Start of Frame Low Register	16	20
0FH	SOFH†	Start of Frame High Register	15	19
10H	FADDR	Function Address Register	21	26
11H	SCR	System Control Register	30	36
12H	SSR†	System Status Register	31	37
14H	SBI†	Serial Bus Interrupt Register	13	17
15H	SBI1†	Serial Bus Interrupt Register 1	14	18
16H	SBIE	Serial Bus Interrupt Enable Register	11	16
17H	SBIE1	Serial Bus Interrupt Enable Register 1	12	16
18H	REV	Hardware Revision Register	32	37
19H	LOCK	Suspend Power-Off Locking Register	33	38
1AH	PEND	Pend Hardware Status Update Register	34	38
1BH	SCRATCH	Scratch Firmware Information Register	35	38
1CH	MCSR	Miscellaneous Control/Status Register	36	39
1DH	DSAV	Data Set Available	37	40
1EH	DSAV1	Data Set Available 1	38	40

* Indexed by EPINDEX.

† Contains shared bits. See Special Firmware Action for Shared Register Bits section.

Register Interface (continued)

Special Firmware Action for Shared Register Bits

Since the USS-820D registers are not bit-addressable and contain several bits that may be written by either firmware or hardware (shared bits), special care must be taken to avoid incorrect behavior. In particular, firmware must be careful not to write a bit after hardware has updated the bit, but before firmware has recognized the hardware update of the bit.

There are two general cases where this may occur:

1. Direct collision—Firmware does a read-modify-write sequence to update a register bit, but between the firmware read and firmware write, hardware updates the bit. For example, in dual-packet mode, hardware could update an SBI/SBI1 bit while firmware is simultaneously resetting the same SBI/SBI1 bit. This would cause firmware to miss the fact that a new transfer has completed.
2. Indirect collision—Firmware does a read-modify-write sequence to update a register bit, but between the firmware read and firmware write, hardware updates a different bit in the same register. For example, firmware could do a read-modify-write to update the SOFODIS bit of the SOFH register, but at the same time, hardware could be updating the ASOF status bit. Firmware would inadvertently reset the ASOF bit without being aware of the hardware update.

These problems can be avoided through the use of the PEND register, which can only be written by firmware. Firmware must ensure that the PEND register bit is set before writing any registers that contain shared bits.

All shared register bits have two copies: a standard copy and a pended copy. The manner in which these register bits are updated varies depending on the value of the PEND register bit, as described in Table 8. The standard copy is the bit that is read and written during normal operation (PEND = 0). While PEND = 1, hardware updates only affect the pended copy, and firmware updates only affect the standard copy. When firmware resets the PEND bit, the pended copies of the shared bits are used to update the standard copies of the shared bits as described in Table 9. Through these means, hardware updates during a firmware read-modify-write sequence will not be missed.

Table 8. Shared Register Bit Update Behavior (ASOF Example)

Bit	Update Behavior While PEND = 0	Update Behavior While PEND = 1	Update Behavior When Firmware Resets PEND to 0
ASOF (standard copy)	Updated by hardware (firmware must not write this register)	Updated by firmware	Updated as documented in Table 9
ASOF (pended copy)	Not used	Updated by hardware	No longer used

Firmware must execute the following sequence when processing a shared bit (to avoid the direct collision case), or when writing a bit which resides in a register that contains shared bits (to avoid the indirect collision case):

- Set the PEND bit.
- Read the register with the shared bit [Read].
- If processing a shared bit, respond to the shared bit. For example, for an SBI/SBI1 bit, process any data sets present for that endpoint.
- Update the bit [Modify].
- Write the register with the shared bit with the modified data [Write].
- Reset the PEND bit.

When a data set is written to a receive FIFO, that FIFO's SBI/SBI1 register bit will set. Firmware must process the indicated receive data set and, in doing so, manage that FIFO's SBI/SBI1 bit according to the sequence described in this section. In dual-packet mode, it is possible that a second data set will be written to a receive FIFO before firmware has completed processing of the initial data set. This second data set could have been written either before or after firmware set the PEND bit to 1. Therefore, firmware cannot determine whether or not this second receive done indication was saved in the pended copy of the SBI/SBI1 bit. Because of this uncertainty, firmware must process all receive data sets which are present in the indicated FIFO before resetting the PEND bit to 0. If the receive done indication of the second data set was in fact saved in the pended SBI/SBI1 register, then the standard copy of the SBI/SBI1 bit will be set when firmware resets the PEND bit to 0.

Register Interface (continued)

In this case, the SBI/SBI1 bit will be set even though there is no corresponding data set present in the receive FIFO. Therefore, firmware must be prepared to service a receive done interrupt where no data sets are present in the indicated FIFO.

Table 9 shows the values loaded into each of the standard copies of the shared register bits when firmware resets the PEND register bit.

Table 9. Shared Register Update Values When Firmware Resets PEND

Register	Bit(s)	Update Value
SBI	All bits	Set to 1 if standard copy = 1 or pended copy = 1.
SBI1	All bits	Set to 1 if standard copy = 1 or pended copy = 1.
RXSTAT	RXSETUP	Loaded with pended copy if USB action updated RXSETUP while PEND was set.
RXSTAT	EDOVW	Set to 1 if standard copy = 1 or pended copy = 1.
EPCON	RXSTL	Set to 1 if standard copy = 1 or pended copy = 1.
SOFH	ASOF	Set to 1 if standard copy = 1 or pended copy = 1.
SOFH	TS	Loaded with pended copy if USB SOF was received while PEND was set.
SOFL	All bits	Loaded with pended copy if USB SOF was received while PEND was set.
SSR	RESET	Set to 1 if standard copy = 1 or pended copy = 1.

The register bits that are only updated by firmware, but reside in registers with shared bits and must therefore be updated only while PEND is set, are shown in Table 10.

Table 10. Register Bits Only Updated While PEND is Set

Register	Bit(s)
RXSTAT	RXSEQ
EPCON	All bits except RXSTL
SOFH	SOFIE, SOFODIS
SSR	SUSPPO, SUSPDIS, RESUME, SUSPEND

Firmware should attempt to minimize the period during which PEND is set in order to minimize the distortion of the detection of hardware events.

Register Reads with Side Effects

In general, USS-820D register reads do not have side effects—they do not cause any device state to change. The following are exceptions to this rule:

- RXDAT reads cause the internal RX FIFO read pointer to change and possibly cause the RXFLG.RXURF register bit to set.
- RXCNTH/RXCNTL reads while RXFLG.RXFIF = 00 cause the RXFLG.RXURF register bit to set.
- LOCK reads restart the register unlock sequence after suspend (described in *Special Action Required by USS-820/USS-825 After Suspend—AP97-058CMR-04*).
- Any register reads during a register unlock sequence after suspend, other than the LOCK register, cause the unlock sequence to fail and require the sequence to be restarted.

Register Interface (continued)

Register Descriptions

Table 11. Serial Bus Interrupt Enable Register (SBIE)—Address: 16H; Default: 0000 0000B

This register enables and disables the receive and transmit done interrupts for function endpoints 0 through 3.

Bit 7	Bit 6	Bit 5	Bit 4	Bit 3	Bit 2	Bit 1	Bit 0
FRXIE3	FTXIE3	FRXIE2	FTXIE2	FRXIE1	FTXIE1	FRXIE0	FTXIE0
R/W							

Bit*	Symbol	Function/Description
7	FRXIE3	Function Receive Interrupt Enable 3. Enables receive done interrupt for endpoint 3 (FRXD3).
6	FTXIE3	Function Transmit Interrupt Enable 3. Enables transmit done interrupt for endpoint 3 (FTXD3).
5	FRXIE2	Function Receive Interrupt Enable 2. Enables receive done interrupt for endpoint 2 (FRXD2).
4	FTXIE2	Function Transmit Interrupt Enable 2. Enables transmit done interrupt for endpoint 2 (FTXD2).
3	FRXIE1	Function Receive Interrupt Enable 1. Enables receive done interrupt for endpoint 1 (FRXD1).
2	FTXIE1	Function Transmit Interrupt Enable 1. Enables transmit done interrupt for endpoint 1 (FTXD1).
1	FRXIE0	Function Receive Interrupt Enable 0. Enables receive done interrupt for endpoint 0 (FRXD0).
0	FTXIE0	Function Transmit Interrupt Enable 0. Enables transmit done interrupt for endpoint 0 (FTXD0).

* For all bits, a 1 indicates the interrupt is enabled and causes an interrupt to be signaled to the microcontroller. A 0 indicates the associated interrupt source is disabled and cannot cause an interrupt. However, the interrupt bit's value is still reflected in the SBI/SBI1 register. All of these bits can be read/written by firmware.

Table 12. Serial Bus Interrupt Enable Register 1 (SBIE1)—Address: 17H; Default: 0000 0000B

This register enables and disables the receive and transmit done interrupts for function endpoints 4 through 7.

Bit 7	Bit 6	Bit 5	Bit 4	Bit 3	Bit 2	Bit 1	Bit 0
FRXIE7	FTXIE7	FRXIE6	FTXIE6	FRXIE5	FTXIE5	FRXIE4	FTXIE4
R/W							

Bit*	Symbol	Function/Description
7	FRXIE7	Function Receive Interrupt Enable 7. Enables receive done interrupt for endpoint 7 (FRXD7).
6	FTXIE7	Function Transmit Interrupt Enable 7. Enables transmit done interrupt for endpoint 7 (FTXD7).
5	FRXIE6	Function Receive Interrupt Enable 6. Enables receive done interrupt for endpoint 6 (FRXD6).
4	FTXIE6	Function Transmit Interrupt Enable 6. Enables transmit done interrupt for endpoint 6 (FTXD6).
3	FRXIE5	Function Receive Interrupt Enable 5. Enables receive done interrupt for endpoint 5 (FRXD5).
2	FTXIE5	Function Transmit Interrupt Enable 5. Enables transmit done interrupt for endpoint 5 (FTXD5).
1	FRXIE4	Function Receive Interrupt Enable 4. Enables receive done interrupt for endpoint 4 (FRXD4).
0	FTXIE4	Function Transmit Interrupt Enable 4. Enables transmit done interrupt for endpoint 4 (FTXD4).

* For all bits, a 1 indicates the interrupt is enabled and causes an interrupt to be signaled to the microcontroller. A 0 indicates the associated interrupt source is disabled and cannot cause an interrupt. However, the interrupt bit's value is still reflected in the SBI/SBI1 register. All of these bits can be read/written by firmware.

Register Interface (continued)

Table 13. Serial Bus Interrupt Register (SBI)—Address: 14H; Default: 0000 000B

This register contains the USB function's transmit and receive done interrupt flags for nonisochronous endpoints. These bits are never set for isochronous endpoints.

Bit 7	Bit 6	Bit 5	Bit 4	Bit 3	Bit 2	Bit 1	Bit 0
FRXD3	FTXD3	FRXD2	FTXD2	FRXD1	FTXD1	FRXD0	FTXD0
R/W (S*)							

Bit	Symbol	Function/Description
7	FRXD3	Function Receive Done Flag, Endpoint 3.
6	FTXD3	Function Transmit Done Flag, Endpoint 3.
5	FRXD2	Function Receive Done Flag, Endpoint 2.
4	FTXD2	Function Transmit Done Flag, Endpoint 2.
3	FRXD1	Function Receive Done Flag, Endpoint 1.
2	FTXD1	Function Transmit Done Flag, Endpoint 1.
1	FRXD0	Function Receive Done Flag, Endpoint 0.
0	FTXD0	Function Transmit Done Flag, Endpoint 0.

* S = shared bit. See Special Firmware Action for Shared Register Bits section.

For all bits in the interrupt flag register, a 1 indicates that an interrupt is actively pending; a 0 indicates that the interrupt is not active. The interrupt status is shown regardless of the state of the corresponding interrupt enable bit in the SBIE/SBIE1.

Hardware can only set bits to 1. In normal operation, firmware should only clear bits to 0. Firmware can also set the bits to 1 for test purposes. This allows the interrupt to be generated in firmware.

A set receive bit indicates either that valid data is waiting to be serviced in the RX FIFO for the indicated endpoint and that the data was received without error and has been acknowledged, or that data was received with a receive data error requiring firmware intervention to be cleared.

A set transmit bit indicates either that data has been transmitted from the TX FIFO for the indicated endpoint and has been acknowledged by the host, or that data was transmitted with an error requiring firmware intervention to be cleared.

If TXNAKE = 1, this also may indicate that a NAK was sent to the host in response to an IN packet that was received when TXFIF = 00. This condition also sets TXVOID. This SBI/SBI1 setting will persist until firmware clears TXVOID (or clears TXNAKE).

Register Interface (continued)

Table 14. Serial Bus Interrupt 1 Register (SBI1)—Address: 15H; Default: 0000 000B

This register contains the USB function's transmit and receive done interrupt flags for nonisochronous endpoints. These bits are never set for isochronous endpoints.

Bit 7	Bit 6	Bit 5	Bit 4	Bit 3	Bit 2	Bit 1	Bit 0
FRXD7	FTXD7	FRXD6	FTXD6	FRXD5	FTXD5	FRXD4	FTXD4
R/W (S*)							

Bit	Symbol	Function/Description
7	FRXD7	Function Receive Done Flag, Endpoint 7.
6	FTXD7	Function Transmit Done Flag, Endpoint 7.
5	FRXD6	Function Receive Done Flag, Endpoint 6.
4	FTXD6	Function Transmit Done Flag, Endpoint 6.
3	FRXD5	Function Receive Done Flag, Endpoint 5.
2	FTXD5	Function Transmit Done Flag, Endpoint 5.
1	FRXD4	Function Receive Done Flag, Endpoint 4.
0	FTXD4	Function Transmit Done Flag, Endpoint 4.

* S = shared bit. See Special Firmware Action for Shared Register Bits section.

For all bits in the interrupt flag register, a 1 indicates that an interrupt is actively pending; a 0 indicates that the interrupt is not active. The interrupt status is shown regardless of the state of the corresponding interrupt enable bit in the SBIE/SBIE1.

Hardware can only set bits to 1. In normal operation, firmware should only clear bits to 0. Firmware can also set the bits to 1 for test purposes. This allows the interrupt to be generated in firmware.

A set receive bit indicates either that valid data is waiting to be serviced in the RX FIFO for the indicated endpoint and that the data was received without error and has been acknowledged, or that data was received with a receive data error requiring firmware intervention to be cleared.

A set transmit bit indicates either that data has been transmitted from the TX FIFO for the indicated endpoint and has been acknowledged by the host, or that data was transmitted with an error requiring firmware intervention to be cleared.

If TXNAKE = 1, this also may indicate that a NAK was sent to the host in response to an IN packet that was received when TXFIF = 00. This condition also sets TXVOID. This SBI/SBI1 setting will persist until firmware clears TXVOID (or clears TXNAKE).

Register Interface (continued)

Table 15. Start of Frame High Register (SOFH)—Address: 0FH; Default: 0000 000B

This register contains isochronous data transfer enable and interrupt bits and the upper 3 bits of the 11-bit time stamp received from the host.

Bit 7	Bit 6	Bit 5	Bit 4	Bit 3	Bit 2	Bit 1	Bit 0
SOFACK	ASOF	SOFIE	FTLOCK	SOFODIS	TS10	TS9	TS8
R	R/W (S*)	R/W (P*)	R	R/W (P*)	R/W (S*)		

Bit	Symbol	Function/Description
7	SOFACK	SOF Token Received Without Error (Read Only). When set, this bit signifies that the 11-bit time stamp stored in SOFL and SOFH is valid. This bit is updated every time an SOF token is received from the USB bus, and it is cleared when an artificial SOF is generated by the frame timer. This bit is set and cleared by hardware.
6	ASOF	Any Start of Frame. This bit is set by hardware to signify that a new frame has begun. The interrupt can result either from the reception of an actual SOF packet or from an artificially generated SOF from the frame timer. This interrupt is asserted in hardware even if the frame timer is not locked to the USB bus frame timing. When set, this bit indicates that either the actual SOF packet was received or an artificial SOF was generated by the frame timer. Setting this bit to 1 by firmware has the same effect as when it is set by hardware. This bit must be cleared to 0 by firmware if SOFODIS = 1 or if MCSR.FEAT = 1. If SOFODIS and MCSR.FEAT = 0, this bit clears itself after one tCLK, which requires the system to detect start of frame via the SOFN device pin. This bit also serves as the SOF interrupt flag. This interrupt is only asserted in hardware if the SOF interrupt is enabled (SOFIE set) and the interrupt channel is enabled.
5	SOFIE	SOF Interrupt Enable. When set, setting the ASOF bit causes an interrupt request to be generated if the interrupt channel is enabled. Hardware reads this bit but does not write to it.
4	FTLOCK	Frame Timer Lock (Read Only). When set, this bit signifies that the frame timer is presently locked to the USB bus frame time. When cleared, this bit indicates that the frame timer is attempting to synchronize the frame time.
3	SOFODIS	SOF Pin Output Disable. When set, no low pulse is driven to the SOF pin in response to setting the ASOF bit. The SOF pin is driven to 1 when SOFODIS is set. When this bit is clear, setting the ASOF bit causes the SOF pin to be toggled with a low pulse for eight tCLK periods.
2:0	TS[10:8]	Time Stamp Received from Host. TS[10:8] are the upper 3 bits of the 11-bit frame number issued with an SOF token. This time stamp is valid only if the SOFACK bit is set.

* S = shared bit. P = PEND must be set when writing this bit. See Special Firmware Action for Shared Register Bits section.

Register Interface (continued)

Table 16. Start of Frame Low Register (SOFL)—Address: 0EH; Default: 0000 0000B

This register contains the lower 8 bits of the 11-bit time stamp received from the host.

Bit 7	Bit 6	Bit 5	Bit 4	Bit 3	Bit 2	Bit 1	Bit 0
TS7	TS6	TS5	TS4	TS3	TS2	TS1	TS0
R/W (S*)							

Bit	Symbol	Function/Description
7:0	TS[7:0]	Time Stamp Received from Host. This time stamp is valid only if the SOFACK bit in the SOFH register is set. TS[7:0] are the lower 8 bits of the 11-bit frame number issued with an SOF token. The time stamp remains at its previous value if an artificial SOF is generated, and it is up to firmware to update it. These bits are set and cleared by hardware.

* S = shared bit. See Special Firmware Action for Shared Register Bits section.

Table 17. Endpoint Index Register (EPINDEX)—Address: 0AH; Default: 0000 0000B

This register identifies the endpoint pair. The register's contents select the transmit and receive FIFO pair and serve as an index to endpoint-specific special function registers (SFRs).

Bit 7	Bit 6	Bit 5	Bit 4	Bit 3	Bit 2	Bit 1	Bit 0
—					EPINX2	EPINX1	EPINX0
—					R/W		

Bit	Symbol	Function/Description																		
7:3	—	Reserved. Write 0s to these bits. Reads always return 0s.																		
2:0	EPINX[2:0]	<p>Endpoint Index.</p> <table border="0"> <tr> <td>EPINDEX*</td> <td>Function Endpoint</td> </tr> <tr> <td>0000 0000</td> <td>Function Endpoint 0</td> </tr> <tr> <td>0000 0001</td> <td>Function Endpoint 1</td> </tr> <tr> <td>0000 0010</td> <td>Function Endpoint 2</td> </tr> <tr> <td>0000 0011</td> <td>Function Endpoint 3</td> </tr> <tr> <td>0000 0100</td> <td>Function Endpoint 4</td> </tr> <tr> <td>0000 0101</td> <td>Function Endpoint 5</td> </tr> <tr> <td>0000 0110</td> <td>Function Endpoint 6</td> </tr> <tr> <td>0000 0111</td> <td>Function Endpoint 7</td> </tr> </table> <p>The EPINDEX register must not be changed during a sequence of RXDAT reads of a particular data set. See the Receive FIFO section for more details.</p>	EPINDEX*	Function Endpoint	0000 0000	Function Endpoint 0	0000 0001	Function Endpoint 1	0000 0010	Function Endpoint 2	0000 0011	Function Endpoint 3	0000 0100	Function Endpoint 4	0000 0101	Function Endpoint 5	0000 0110	Function Endpoint 6	0000 0111	Function Endpoint 7
EPINDEX*	Function Endpoint																			
0000 0000	Function Endpoint 0																			
0000 0001	Function Endpoint 1																			
0000 0010	Function Endpoint 2																			
0000 0011	Function Endpoint 3																			
0000 0100	Function Endpoint 4																			
0000 0101	Function Endpoint 5																			
0000 0110	Function Endpoint 6																			
0000 0111	Function Endpoint 7																			

* The EPINDEX register identifies the endpoint pair and selects the associated transmit and receive FIFO pair. The value in this register plus SFR addresses select the associated band of endpoint-indexed SFRs (TXDAT, TXCON, TXFLG, TXCNTH/L, RXDAT, RXCON, RXFLG, RXCNTH/L, EPCON, TXSTAT, and RXSTAT).

Register Interface (continued)

Table 18. Endpoint Control Register (EPCON)—Address: 0BH; Default: Endpoint 0 = 0011 0101B; Others = 0001 0000B

This SFR configures the operation of the endpoint specified by EPINDEX. This register is endpoint indexed.

Bit 7	Bit 6	Bit 5	Bit 4	Bit 3	Bit 2	Bit 1	Bit 0
RXSTL	TXSTL	CTLEP	RXSPM	RXIE	RXEPEN	TXOE	TXEPEN
R/W (S*)	R/W(P*)						

Bit	Symbol	Function/Description
7	RXSTL	Stall Receive Endpoint. When set, this bit stalls the receive endpoint. Firmware must clear this bit only after the host has intervened through commands sent down endpoint 0. When this bit is set and RXSETUP is clear, the receive endpoint responds with a STALL handshake to a valid OUT token. When this bit is set and RXSETUP is set, the receive endpoint will NACK. This bit does not affect the reception of SETUP tokens by a control endpoint. This bit is set by the hardware if the data phase of the status stage of a control transfer does not use the correct data PID (DATA1) or has more than 0 data bytes.
6	TXSTL	Stall Transmit Endpoint. When set, this bit stalls the transmit endpoint. Firmware must clear this bit only after the host has intervened through commands sent down endpoint 0. When this bit is set and RXSETUP is clear, the transmit endpoint responds with a STALL handshake to a valid IN token. When this bit is set and RXSETUP is set, the receive endpoint will NACK.
5	CTLEP	Control Endpoint. When set, this bit configures the endpoint as a control endpoint. Only control endpoints are capable of receiving SETUP tokens.
4	RXSPM	Receive Single-Packet Mode. When set, this bit configures the receive endpoint for single data packet operation. When enabled, only a single data packet is allowed to reside in the receive FIFO. Note: For control endpoints (CTLEP = 1), this bit should be set for single-packet mode operation as the recommended firmware model. However, it is possible to have a control endpoint configured in dual-packet mode as long as the firmware handles the endpoint correctly.
3	RXIE	Receive Input Enable. When set, this bit enables data from the USB to be written into the receive FIFO. If cleared, the endpoint responds to an OUT token by ignoring the data and returning a NACK handshake to the host (unless RXSTL is set, in which case a STALL is returned). This bit does not affect a valid SETUP token.
2	RXEPEN	Receive Endpoint Enable. When set, this bit enables the receive endpoint. When disabled, the endpoint does not respond to a valid OUT or SETUP token. This bit is hardware read only and has the highest priority among RXIE and RXSTL. Note: Endpoint 0 is enabled for reception upon reset.
1	TXOE	Transmit Output Enable. When set, this bit enables the data in TXDAT to be transmitted. If cleared, the endpoint returns a NACK handshake to a valid IN token if the TXSTL bit is not set.
0	TXEPEN	Transmit Endpoint Enable. When set, this bit enables the transmit endpoint. When disabled, the endpoint does not respond to a valid IN token. This bit is hardware read only. Note: Endpoint 0 is enabled for transmission upon reset.

* S = shared bit. P = PEND must be set when writing this bit. See Special Firmware Action for Shared Register Bits section.

Register Interface (continued)

Table 19. Endpoint Transmit Status Register (TXSTAT)—Address: 0CH; Default: 0000 0000B

This register contains the current endpoint status of the transmit FIFO specified by EPINDEX. This register is endpoint indexed.

Bit 7	Bit 6	Bit 5	Bit 4	Bit 3	Bit 2	Bit 1	Bit 0
TXSEQ	TXDSAM	TXNAKE	TXFLUSH	TXSOVW	TXVOID	TXERR	TXACK
R/W*	R/W	R/W	R	W*	R/W†	R	

Bit	Symbol	Function/Description
7	TXSEQ	Transmitter Current Sequence Bit (Read, Conditional Write). * This bit is transmitted in the next PID and toggled on a valid ACK handshake. This bit is toggled by hardware on a valid SETUP token. This bit can be written by firmware if the TXSOVW bit is set when written together with the next TXSEQ value.
6	TXDSAM	Transmit Data-Set-Available Mode. If set, a NAK response to an IN token causes the corresponding RXAV/TXAV bit in the DSAV register to set, and the DSA output pin to assert (if enabled by MCSR.BDFEAT), rather than the standard condition (transmit data set empty). This only occurs on NAKs caused by TXFIF = 00. This bit must not be set for isochronous endpoints. When reset to 0 (along with MCSR.FEAT, MCSR.BDFEAT, and TXSTAT.TXNAKE), the device will behave like revision B.
5	TXNAKE	Transmit NAK Mode Enable. If set, a NAK response to an IN token causes the TXVOID bit and the corresponding bits in the SBI/SBI1 register to set, causing an IRQN interrupt (if enabled). This only occurs on NAKs caused by TXFIF = 00. This bit must not be set for isochronous endpoints. When set this bit also changes the meaning and usage of the TXSTAT.TXVOID bit. When reset to 0 (along with MCSR.FEAT, MCSR.BDFEAT, and TXSTAT.TXDSAM), the device will behave like revision B.
4	TXFLUSH	Transmit FIFO Packet Flushed (Read Only). Updated at each SOF. When set, this bit indicates that hardware flushed a stale isochronous data packet from the transmit FIFO at SOF. Behavior when MCSR.FEAT = 0: To guard against a missed IN token in isochronous mode, if, with TXFIF[1:0] = 11, no IN token is received for the current endpoint, hardware automatically flushes the oldest packet and decrements the TXFIF[1:0] value. This flush does not occur if there is only one data set present (TXFIF = 01/10). Behavior when MCSR.FEAT = 1: A firmware data set write causes a TXFIF bit to set. For isochronous endpoints, this data set does not become visible to the host until the next SOF. The data set is intended to be read out during that frame. If that read does not occur (possibly due to a lost IN packet), that data set is flushed at the next SOF, setting TXFLUSH. If firmware writes two data sets during a single frame (TXFIF must have equalled 00 at the start of that frame), the first, older data set written is flushed at the subsequent SOF, setting TXFLUSH.

* For normal operation, this bit should not be modified by the user except as required by the implementation of USB standard commands, such as SET_CONFIGURATION, SET_INTERFACE, and CLEAR_FEATURE [stall]. The SIE handles all sequence bit tracking required by normal USB traffic, as documented in the USB specification, Section 8.6.

† Only writable if TXNAKE = 1.

Register Interface (continued)

Table 19. Endpoint Transmit Status Register (TXSTAT)—Address: 0CH; Default: 0000 0000B (continued)

Bit	Symbol	Function/Description
3	TXSOVW	Transmit Data Sequence Overwrite Bit.* Writing a 1 to this bit allows the value of the TXSEQ bit to be overwritten. Writing a 0 to this bit has no effect on TXSEQ. This bit always returns 0 when read.
2	TXVOID	Transmit Void.† Behavior when TXNAKE = 0: This bit is read only if TXNAKE = 0. Indicates a void condition has occurred in response to a valid IN token. Transmit void is closely associated with the NACK/STALL handshake returned by the function after a valid IN token. This void condition occurs when the endpoint output is disabled (TXOE = 0) or stalled (TXSTL = 1), the corresponding receive FIFO contains a setup packet (RXSETUP = 1), the FIFO contains no valid data sets (TXFIF = 00), or there is an existing FIFO error (TXURF = 1 or TXOVF = 1). This bit is used to check any NACK/STALL handshake returned by the function. This bit does not affect the FTXDx, TXERR, or TXACK bits. This bit is updated by hardware at the end of a nonisochronous transaction in response to a valid IN token. For isochronous transactions, this bit is not updated until the next SOF. This bit is not updated at SOF if TXFLUSH is performed. Behavior when TXNAKE = 1: When TXNAKE = 1, this bit becomes writable by firmware. The meaning of the bit is also changed, to indicate only that a NAK was sent to the host in response to an IN when TXFIF = 00. Hardware setting of this bit always takes priority over firmware writes. Hardware setting of this bit also causes the corresponding SBI/SBI1 bit to set, possibly causing an interrupt. That setting will persist until TXVOID is cleared by firmware.
1	TXERR	Transmit Error (Read Only). Indicates an error condition has occurred with the transmission. Complete or partial data has been transmitted. The error can be one of the following: 1. Data transmitted successfully but no handshake received. 2. Transmit FIFO goes into underrun condition while transmitting. These conditions also cause the corresponding transmit done bit, FTXDx in SBI or SBI1, to be set. For nonisochronous transactions, TXERR is updated by hardware along with the TXACK bit at the end of data transmission. TXERR and TXACK are updated at the same time—one bit is set to 1, and the other is reset to 0. For isochronous transactions, TXERR is not updated until the next SOF. This bit is not updated at SOF if TXFLUSH is performed.
0	TXACK	Transmit Acknowledge (Read Only). Indicates data transmission completed and acknowledged successfully. This condition also causes the corresponding transmit done bit, FTXDx in SBI or SBI1, to be set. For nonisochronous transactions, TXACK is updated by hardware along with the TXERR bit at the end of data transmission. TXERR and TXACK are updated at the same time—one bit is set to 1, and the other is reset to 0. For isochronous transactions, TXACK is not updated until the next SOF. This bit is not updated at SOF if TXFLUSH is performed.

* For normal operation, this bit should not be modified by the user except as required by the implementation of USB standard commands, such as SET_CONFIGURATION, SET_INTERFACE, and CLEAR_FEATURE [stall]. The SIE handles all sequence bit tracking required by normal USB traffic, as documented in the USB specification, Section 8.6.

† Only writable if TXNAKE = 1.

Register Interface (continued)

Table 20. Endpoint Receive Status Register (RXSTAT)—Address: 0DH; Default: 0000 0000B

This register contains the current endpoint status of the receive FIFO specified by EPINDEX. This register is an endpoint-indexed SFR.

Bit 7	Bit 6	Bit 5	Bit 4	Bit 3	Bit 2	Bit 1	Bit 0
RXSEQ	RXSETUP	STOVW	EDOVW	RXSOVW	RXVOID	RXERR	RXACK
R/W* (P†)	R/W (S†)	R	R/W (S†)	W (P†)	R		

Bit	Symbol	Function/Description
7	RXSEQ	Receiver Endpoint Sequence Bit (Read, Conditional Write). * This bit is toggled on completion of an ACK handshake in response to an OUT token. This bit is set (or cleared) by hardware after reception of a SETUP token. If the RXSOVW bit is set, this bit can be written by firmware when written along with the new RXSEQ value. Note: Always verify this bit after writing to ensure that there is no conflict with hardware, which may occur if a new SETUP token is received.
6	RXSETUP	Received SETUP Token. This bit is set by hardware when a valid SETUP token has been received. When set, this bit causes received IN or OUT tokens to be NACKed until the bit is cleared to allow proper data management for the transmit and receive FIFOs from the previous transaction. IN or OUT tokens are NACKed even if the endpoint is stalled (RXSTL or TXSTL) to allow a control transaction to clear a stalled endpoint. Firmware must clear this bit after it has finished reading out the SETUP packet and is prepared for the next stage of the control transaction (data or status). For a stalled control endpoint, this bit should not be cleared until the RXSTL/TXSTL bits have been cleared.
5	STOVW	Start Overwrite Flag (Read Only). This bit is set by hardware upon receipt of a SETUP token for any control endpoint to indicate that the receive FIFO is being overwritten with new SETUP data. When set, the FIFO state (RXFIF and read pointer) resets and is locked for this endpoint until EDOVW is set. This prevents a prior, ongoing firmware read from corrupting the read pointer as the receive FIFO is being cleared and new data is being written into it. This bit is cleared by hardware at the end of handshake phase transmission of the SETUP stage. This bit is used only for control endpoints.
4	EDOVW	End Overwrite Flag. This flag is set by hardware during the handshake phase of a SETUP stage. It is set after every SETUP packet is received and must be cleared prior to reading the contents of the FIFO. When set, the FIFO state (RXFIF and read pointer) remains locked for this endpoint until this bit is cleared. This prevents a prior, ongoing firmware read from corrupting the read pointer after the new data has been written into the receive FIFO. This bit is used only for control endpoints.
3	RXSOVW	Receive Data Sequence Overwrite Bit. * Writing a 1 to this bit allows the value of the RXSEQ bit to be overwritten. Writing a 0 to this bit has no effect on RXSEQ. This bit always returns 0 when read.

* For normal operation, this bit should not be modified by the user except as required by the implementation of USB standard commands, such as SET_CONFIGURATION, SET_INTERFACE, and CLEAR_FEATURE [stall]. The SIE handles all sequence bit tracking required by normal USB traffic, as documented in the USB specification, Section 8.6.

† S = shared bit. P = PEND must be set when writing this bit. See Special Firmware Action for Shared Register Bits section.

Register Interface (continued)

Table 20. Endpoint Receive Status Register (RXSTAT)—Address: 0DH; Default: 0000 0000B (continued)

Bit	Symbol	Function/Description
2	RXVOID	<p>Receive Void (Read Only). Indicates a void condition has occurred in response to a valid OUT token. Receive void is closely associated with the NACK/STALL handshake returned by the function after a valid OUT token. This void condition occurs when the endpoint input is disabled (RXIE = 0) or stalled (RXSTL = 1), the FIFO contains a setup packet (RXSETUP = 1), the FIFO has no available data sets (RXFIF = 11, or RXFIF = 01/10 and RXSPM = 1), or there is an existing FIFO error (RXURF = 1 or RXOVF = 1).</p> <p>This bit is set and cleared by hardware. For nonisochronous transactions, this bit is updated by hardware at the end of the transaction in response to a valid OUT token. For isochronous transactions, it is not updated until the next SOF.</p>
1	RXERR	<p>Receive Error (Read Only). Set when an error condition has occurred with the reception of a SETUP or OUT transaction. Complete or partial data has been written into the receive FIFO. No handshake is returned. The error can be one of the following:</p> <ol style="list-style-type: none"> 1. Data failed CRC check. 2. Bit stuffing error. 3. A receive FIFO goes into overrun or underrun condition while receiving. <p>This bit is updated by hardware at the end of a valid SETUP or OUT token transaction (nonisochronous) or at the next SOF on each valid OUT token transaction (isochronous).</p> <p>These conditions also cause the corresponding FRXDx bit of SBI or SBI1 to be set. RXERR is updated with the RXACK bit at the end of data reception. RXERR and RXACK are updated at the same time—one bit is set to 1, and the other is reset to 0.</p>
0	RXACK	<p>Receive Acknowledge (Read Only). This bit is set when an ACK handshake is sent in response to data being written to the receive FIFO. This read-only bit is updated by hardware at the end of a valid SETUP or OUT token transaction (nonisochronous) or at the next SOF on each valid OUT token transaction (isochronous).</p> <p>This condition also causes the corresponding FRXDx bit of SBI or SBI1 to be set. RXACK is updated with the RXERR bit at the end of data reception. RXERR and RXACK are updated at the same time—one bit is set to 1, and the other is reset to 0.</p>

Register Interface (continued)

Table 21. Function Address Register (FADDR)—Address: 10H; Default: 0000 0000B

This SFR holds the address for the USB function. During bus enumeration, it is written by firmware with a unique value assigned by the host. If MCSR.FEAT = 1, this register is reset to 0 if a USB reset is detected.

Bit 7	Bit 6	Bit 5	Bit 4	Bit 3	Bit 2	Bit 1	Bit 0
—	A6	A5	A4	A3	A2	A1	A0
—	R/W						

Bit	Symbol	Function/Description
7	—	Reserved. Write 0 to this bit. Reads always return 0.
6:0	A[6:0]	7-Bit Programmable Function Address. This register is written by firmware as a result of commands received via endpoint 0.

Table 22. Transmit FIFO Data Register (TXDAT)—Address: 00H; Default: 0000 0000B

Data to be transmitted by the FIFO specified by EPINDEX is first written to this register. This register is endpoint indexed. TXDAT must not be written if TXFIF = 11.

Bit 7	Bit 6	Bit 5	Bit 4	Bit 3	Bit 2	Bit 1	Bit 0
TXDAT7	TXDAT6	TXDAT5	TXDAT4	TXDAT3	TXDAT2	TXDAT1	TXDAT0
W							

Bit	Symbol	Function/Description
7:0	TXDAT[7:0]	Transmit Data Byte (Write Only). To write data to the transmit FIFO, write to this register. The write pointer is incremented automatically after a write.

Table 23. Transmit FIFO Byte-Count High and Low Registers (TXCNTH, TXCNTL)—Address: TXCNTH = 02H, TXCNTL = 01H; Default: TXCNTH = 0000 0000B; TXCNTL = 0000 0000B

Written by firmware to indicate the number of bytes just written to the transmit FIFO specified by EPINDEX. This register is endpoint indexed. TXCNTL should be written after TXCNTH. TXCNTL write increments TXFIF, validating the data set just written.

Bit 15	Bit 14	Bit 13	Bit 12	Bit 11	Bit 10	Bit 9	Bit 8
—						BC9	BC8
—						R/W	

Bit 7	Bit 6	Bit 5	Bit 4	Bit 3	Bit 2	Bit 1	Bit 0
BC7	BC6	BC5	BC4	BC3	BC2	BC1	BC0
R/W							

Bit	Symbol	Function/Description
15:10	—	Reserved. Write 0s to these bits. Reads always return 0s.
9:0	BC[9:0]	Transmit Byte Count (Write, Conditional Read). 10-bit, ring buffer. These bits store transmit byte count (TXCNT).

Note: To send a status stage after a control write, no data control command, or a null packet, write 0 to TXCNT.

Register Interface (continued)

Table 24. USB Transmit FIFO Control Register (TXCON)—Address: 03H; Default: 0000 0100B

This register controls the transmit FIFO specified by EPINDEX. This register is endpoint indexed.

Bit 7	Bit 6	Bit 5	Bit 4	Bit 3	Bit 2	Bit 1	Bit 0
TXCLR	FFSZ1	FFSZ0	—	TXISO	ATM	ADVRM	REVRP
R/W			—	R/W			

Bit	Symbol	Function/Description															
7	TXCLR	Transmit FIFO Clear. Setting this bit flushes the transmit FIFO, resets all the read/write pointers and markers, resets the TXCNTH and TXCNTL registers, resets the TXFLUSH, TXVOID, TXERR, and TXACK bits of the TXSTAT register, sets the TXEMP bit in TXFLG, and clears all other bits in TXFLG. Hardware clears this bit after the flush. Setting this bit does not affect the TXSEQ bit in the TXSTAT register. This bit should only be set when the endpoint is known to be inactive or there is a FIFO error present.															
6:5	FFSZ[1:0]	FIFO Size. These bits select the size of the transmit FIFO. <table border="1"> <thead> <tr> <th>FFSZ[1:0]</th> <th>Nonisochronous Size</th> <th>Isochronous Size</th> </tr> </thead> <tbody> <tr> <td>00</td> <td>16</td> <td>64</td> </tr> <tr> <td>01</td> <td>64</td> <td>256</td> </tr> <tr> <td>10</td> <td>8*</td> <td>512</td> </tr> <tr> <td>11</td> <td>32*</td> <td>1024</td> </tr> </tbody> </table>	FFSZ[1:0]	Nonisochronous Size	Isochronous Size	00	16	64	01	64	256	10	8*	512	11	32*	1024
FFSZ[1:0]	Nonisochronous Size	Isochronous Size															
00	16	64															
01	64	256															
10	8*	512															
11	32*	1024															
4	—	Reserved. Write 0 to this bit. Reads always return 0.															
3	TXISO	Transmit Isochronous Data. Firmware sets this bit to indicate that the transmit FIFO contains isochronous data. The SIE uses this bit to determine if a handshake is required at the end of a transmission.															
2	ATM	Automatic Transmit Management. [†] Setting this bit (the default value) causes the read pointer and read marker to be adjusted automatically as indicated: <table border="1"> <thead> <tr> <th>Status</th> <th>Read Pointer</th> <th>Read Marker</th> </tr> </thead> <tbody> <tr> <td>ACK</td> <td>Unchanged</td> <td>Advanced (1)</td> </tr> <tr> <td>NACK</td> <td>Reversed (2)</td> <td>Unchanged</td> </tr> </tbody> </table> <p>1. To origin of next data set. 2. To origin of the data set last read.</p> <p>This bit should always be set, except for test purposes. Setting this bit disables ADVRM and REVRP. This bit can be set and cleared by firmware. Hardware neither clears nor sets this bit. This bit must always be set for isochronous endpoints (TXISO = 1).</p>	Status	Read Pointer	Read Marker	ACK	Unchanged	Advanced (1)	NACK	Reversed (2)	Unchanged						
Status	Read Pointer	Read Marker															
ACK	Unchanged	Advanced (1)															
NACK	Reversed (2)	Unchanged															
1	ADVRM	Advance Read Marker Control (Non-ATM Mode Only). [†] Setting this bit prepares for the next packet transmission by advancing the read marker to the origin of the next data packet (the position of the read pointer). Hardware clears this bit after the read marker is advanced. This bit is effective only when the REVRP, ATM, and TXCLR bits are clear.															
0	REVRP	Reverse Read Pointer (Non-ATM Mode Only). [†] In the case of a bad transmission, the same data stack may need to be available for retransmit. Setting this bit reverses the read pointer to point to the origin of the last data set (the position of the read marker) so that the SIE can reread the last set for retransmission. Hardware clears this bit after the read pointer is reversed. This bit is effective only when the ADVRM, ATM, and TXCLR bits are all clear.															

* Assumes MCSR.FEAT = 1. If MCSR.FEAT = 0, these FFSZ settings indicate 64 bytes.

[†] ATM mode is recommended for normal operation. ADVRM and REVRP, which control the read marker and read pointer when ATM = 0, are used for test purposes.

Register Interface (continued)

Table 25. Transmit FIFO Flag Register (TXFLG)—Address: 04H; Default: 0000 1000B

These flags indicate the status of data packets in the transmit FIFO specified by EPINDEX. This register is endpoint indexed.

Bit 7	Bit 6	Bit 5	Bit 4	Bit 3	Bit 2	Bit 1	Bit 0
TXFIF1	TXFIF0	—		TXEMP	TXFULL	TXURF	TXOVF
R		—		R		R/W	

Bit	Symbol	Function/Description																																																		
7:6	TXFIF[1:0]	<p>Transmit FIFO Index Flags (Read Only). These flags indicate which data sets are present in the transmit FIFO (see below).</p> <p style="text-align: center;">Data Sets Present</p> <table border="1"> <thead> <tr> <th>TXFIF[1:0]</th> <th>ds1</th> <th>ds0</th> <th>Status</th> </tr> </thead> <tbody> <tr> <td>00</td> <td>No</td> <td>No</td> <td>Empty</td> </tr> <tr> <td>01</td> <td>No</td> <td>Yes</td> <td>1 set</td> </tr> <tr> <td>10</td> <td>Yes</td> <td>No</td> <td>1 set</td> </tr> <tr> <td>11</td> <td>Yes</td> <td>Yes</td> <td>2 sets</td> </tr> </tbody> </table> <p>The TXFIF bits are set in sequence after each write to TXCNT to reflect the addition of a data set. Likewise, the TXFIF1 and TFIF0 are cleared in sequence after each advance of the read marker to indicate that the set is effectively discarded. The bit is cleared whether the read marker is advanced by firmware (setting ADVRM) or automatically by hardware (ATM = 1). The next-state table for the TXFIF bits is shown below:</p> <table border="1"> <thead> <tr> <th>TXFIF[1:0]</th> <th>Operation</th> <th>Next TXFIF[1:0]</th> </tr> </thead> <tbody> <tr> <td>00</td> <td>Write TXCNT</td> <td>01</td> </tr> <tr> <td>01</td> <td>Write TXCNT</td> <td>11</td> </tr> <tr> <td>10</td> <td>Write TXCNT</td> <td>11</td> </tr> <tr> <td>11</td> <td>Write TXCNT</td> <td>11 (TXOVF = 1)</td> </tr> <tr> <td>00</td> <td>Advance Read Marker</td> <td>00</td> </tr> <tr> <td>01</td> <td>Advance Read Marker</td> <td>00</td> </tr> <tr> <td>11</td> <td>Advance Read Marker</td> <td>10/01</td> </tr> <tr> <td>10</td> <td>Advance Read Marker</td> <td>00</td> </tr> <tr> <td>XX</td> <td>Reverse Read Pointer</td> <td>Unchanged</td> </tr> </tbody> </table> <p>In isochronous mode, TXOVF, TXURF, and TXFIF are handled using the following rule: firmware events cause status change immediately, while USB events cause status change only at SOF. TXFIF is incremented by firmware and decremented by the USB. Therefore, writes to TXCNT increment TXFIF immediately. However, a successful USB transaction any time within a frame decrements TXFIF only at SOF.</p> <p>The TXFIF flags must be checked before and after writes to the transmit FIFO and TXCNT for traceability. See the TXFLUSH bit in TXSTAT.</p> <p>If MCSR.FEAT = 0: TXFIF bits are immediately visible to the host after a firmware write—the device will send the indicated data set(s) to the host in response to an IN.</p>	TXFIF[1:0]	ds1	ds0	Status	00	No	No	Empty	01	No	Yes	1 set	10	Yes	No	1 set	11	Yes	Yes	2 sets	TXFIF[1:0]	Operation	Next TXFIF[1:0]	00	Write TXCNT	01	01	Write TXCNT	11	10	Write TXCNT	11	11	Write TXCNT	11 (TXOVF = 1)	00	Advance Read Marker	00	01	Advance Read Marker	00	11	Advance Read Marker	10/01	10	Advance Read Marker	00	XX	Reverse Read Pointer	Unchanged
TXFIF[1:0]	ds1	ds0	Status																																																	
00	No	No	Empty																																																	
01	No	Yes	1 set																																																	
10	Yes	No	1 set																																																	
11	Yes	Yes	2 sets																																																	
TXFIF[1:0]	Operation	Next TXFIF[1:0]																																																		
00	Write TXCNT	01																																																		
01	Write TXCNT	11																																																		
10	Write TXCNT	11																																																		
11	Write TXCNT	11 (TXOVF = 1)																																																		
00	Advance Read Marker	00																																																		
01	Advance Read Marker	00																																																		
11	Advance Read Marker	10/01																																																		
10	Advance Read Marker	00																																																		
XX	Reverse Read Pointer	Unchanged																																																		

Register Interface (continued)

Table 25. Transmit FIFO Flag Register (TXFLG)—Address: 04H; Default: 0000 1000B (continued)

Bit	Symbol	Function/Description
7:6	TXFIF[1:0]	<p>Transmit FIFO Index Flags (Read Only) (continued).</p> <p>If MCSR.FEAT = 1: TXFIF bits are not visible to the host until the first SOF is written, which occurs after the data set. Prior to that SOF, the device will return a zero-length data set in response to an IN (unless there is another, older data set present from the prior frame). This ensures that a given data set may only be sent during the subsequent frame, as required by the USB specification. This behavior also allows firmware to occasionally be late in writing a data set (write complete after SOF), without losing frame/data synchronization with the host. The late data set write will cause a zero-length data set to be sent to the host during the intended frame. The late set will be flushed at the end of the next frame, assuming firmware also writes the correct data set during that frame (see TXSTAT.TXFLUSH description). Firmware must not be late on consecutive frames (this will cause a loss of frame/data synchronization with the host), data sets may be sent during the wrong frame.</p> <p>Note: Firmware can enforce single-packet mode by only writing a new data set to the transmit FIFO if there are currently no data sets present in the FIFO (TXFIF = 00). To simplify firmware development, configure control endpoints in single-packet mode.</p>
5:4	—	Reserved. Write 0s to these bits. Reads always return 0s.
3	TXEMP	<p>Transmit FIFO Empty Flag (Read Only). Hardware sets this bit when firmware has not yet written any data bytes to the current FIFO data set being written. Hardware clears this bit when the empty condition no longer exists.</p> <p>This bit always tracks the current transmit FIFO status regardless of isochronous or nonisochronous mode.</p>
2	TXFULL	<p>Transmit FIFO Full Flag (Read Only). Hardware sets this bit when the number of bytes that firmware writes to the current transmit FIFO data set equals the FIFO size. Hardware clears this bit when the full condition no longer exists.</p> <p>This bit always tracks the current transmit FIFO status regardless of isochronous or nonisochronous mode. Check this bit to avoid causing a TXOVF condition.</p>
1	TXURF	<p>Transmit FIFO Underrun Flag (Read, Clear Only). Hardware sets this flag when a read is attempted from an empty transmit FIFO. (This is caused when the value written to TXCNT is greater than the number of bytes written to TXDAT.) This bit must be cleared by firmware through TXCLR. When this flag is set, the FIFO is in an unknown state; therefore, it is recommended that the FIFO is reset in the error management routine using the TXCLR bit in TXCON.</p> <p>When the transmit FIFO underruns, the read pointer does not advance; it remains locked in the empty position.</p> <p>When this bit is set, all transmissions are NACKed.</p> <p>In isochronous mode, TXOVF, TXURF, and TXFIF are handled using the following rule: firmware events cause status change immediately, while USB events cause status change only at SOF. Since underrun can only be caused by USB, TXURF is updated at the next SOF regardless of where the underrun occurs in the frame.</p>

Register Interface (continued)

Table 25. Transmit FIFO Flag Register (TXFLG)—Address: 04H; Default: 0000 1000B (continued)

Bit	Symbol	Function/Description
0	TXOVF	<p>Transmit FIFO Overrun Flag (Read, Clear Only). This bit is set when an additional byte is written to a full FIFO, or TXCNT is written while TXFIF[1:0] = 11. This bit must be cleared by firmware through TXCLR. When this bit is set, the FIFO is in an unknown state; thus, it is recommended that the FIFO is reset in the error management routine using the TXCLR bit in TXCON.</p> <p>When the transmit FIFO overruns, the write pointer does not advance; it remains locked in the full position. Check this bit after loading the FIFO prior to writing the byte count register.</p> <p>When this bit is set, all transmissions are NACKed.</p> <p>In isochronous mode, TXOVF, TXURF, and TXFIF are handled using the following rule: firmware events cause status change immediately, while USB events cause status change only at SOF. Since overrun can only be caused by firmware, TXOVF is updated immediately. Check the TXOVF flag after writing to the transmit FIFO before writing to TXCNT.</p>

Table 26. Receive FIFO Data Register (RXDAT)—Address: 05H; Default: 0000 0000B

Receive FIFO data specified by EPINDEX is stored and read from this register. This register is endpoint indexed.

Bit 7	Bit 6	Bit 5	Bit 4	Bit 3	Bit 2	Bit 1	Bit 0
RXDAT[7:0]							
R							

Bit	Symbol	Function/Description
7:0	RXDAT[7:0]	<p>Receive FIFO Data Register (Read Only). To write to the receive FIFO, the SIE writes to this register. To read data from the receive FIFO, the CPU reads from this register. The write pointer and read pointer are incremented automatically after a write and read, respectively.</p> <p>The EPINDEX register must not be changed during a sequence of RXDAT reads of a particular data set. See the Receive FIFO section for more details.</p>

Register Interface (continued)

Table 27. Receive FIFO Byte-Count High and Low Registers (RXCNTH, RXCNTL)—Address: RXCNTH = 07H, RXCNTL = 06H; Default: RXCNTH = 0000 0000B, RXCNTL = 0000 0000B

High and low registers are in a two-register ring buffer that is used to store the byte count for the data packets received in the receive FIFO specified by EPINDEX. These registers are endpoint indexed.

Bit 15	Bit 14	Bit 13	Bit 12	Bit 11	Bit 10	Bit 9	Bit 8
—						BC9	BC8
—						R	

Bit 7	Bit 6	Bit 5	Bit 4	Bit 3	Bit 2	Bit 1	Bit 0
BC7	BC6	BC5	BC4	BC3	BC2	BC1	BC0
R							

Bit	Symbol	Function/Description
15:10	—	Reserved. Write 0s to these bits. Reads always return 0s.
9:0	BC[9:0]	Receive Byte Count (Read Only). 10-bit, ring buffer byte. Stores receive byte count (RXCNT).

Table 28. Receive FIFO Control Register (RXCON)—Address: 08H; Default: 0000 0100B

Controls the receive FIFO specified by EPINDEX. This register is endpoint indexed.

Bit 7	Bit 6	Bit 5	Bit 4	Bit 3	Bit 2	Bit 1	Bit 0
RXCLR	FFSZ1	FFSZ0	RXFFRC	RXISO	ARM	ADVWM	REVWP
R/W							

Bit	Symbol	Function/Description															
7	RXCLR	Receive FIFO Clear. Setting this bit flushes the receive FIFO, resets all the read/write pointers and markers, resets the RXSETUP, STOVW, EDOVW, RXVOID, RXERR, and RXACK bits of the RXSTAT register, sets the RXEMP bit in RXFLG register, and clears all other bits in RXFLG register. Hardware clears this bit when the flush operation is completed. Setting this bit does not affect the RXSEQ bit of RXSTAT. This bit should only be set when the endpoint is disabled or there is a FIFO error present. Firmware should never set this bit to clear a SETUP packet. The next SETUP packet will automatically clear the receive FIFO.															
6:5	FFSZ[1:0]	FIFO Size. These bits select the size of the receive FIFO. <table border="1"> <thead> <tr> <th>FFSZ[1:0]</th> <th>Nonisochronous Size</th> <th>Isochronous Size</th> </tr> </thead> <tbody> <tr> <td>00</td> <td>16</td> <td>64</td> </tr> <tr> <td>01</td> <td>64</td> <td>256</td> </tr> <tr> <td>10</td> <td>8*</td> <td>512</td> </tr> <tr> <td>11</td> <td>32*</td> <td>1024</td> </tr> </tbody> </table>	FFSZ[1:0]	Nonisochronous Size	Isochronous Size	00	16	64	01	64	256	10	8*	512	11	32*	1024
FFSZ[1:0]	Nonisochronous Size	Isochronous Size															
00	16	64															
01	64	256															
10	8*	512															
11	32*	1024															

* Assumes MCSR.FEAT = 1. If MCSR.FEAT = 0, these FFSZ settings indicate 64 bytes.

Register Interface (continued)

Table 28. Receive FIFO Control Register (RXCON)—Address: 08H; Default: 0000 0100B (continued)

Bit	Symbol	Function/Description									
4	RXFFRC	<p>FIFO Read Complete. When set, the receive FIFO is released when a data set read is complete. Setting this bit clears the RXFIF bit (in the RXFLG register), corresponding to the data set that was just read. Hardware clears this bit after the RXFIF bit is cleared. All data from this data set must have been read. For isochronous endpoints, firmware must check RXFLUSH before setting RXFFRC, and the act of setting RXFFRC clears RXFLUSH. See RXFLUSH description for details.</p> <p>Note: FIFO read complete only works if the STOVW and EDOVW bits are both cleared.</p>									
3	RXISO	<p>Receive Isochronous Data. When set, this indicates that the receive FIFO is programmed to receive isochronous data and to set up the USB interface to handle an isochronous data transfer.</p>									
2	ARM	<p>Auto Receive Management.* When set, the write pointer and write marker are adjusted automatically based on the following conditions:</p> <table border="0" style="margin-left: 40px;"> <tr> <td style="text-align: center;">RX Status</td> <td style="text-align: center;">Write Pointer</td> <td style="text-align: center;">Write Marker</td> </tr> <tr> <td style="text-align: center;">ACK</td> <td style="text-align: center;">Unchanged</td> <td style="text-align: center;">Advanced</td> </tr> <tr> <td style="text-align: center;">NACK</td> <td style="text-align: center;">Reversed</td> <td style="text-align: center;">Unchanged</td> </tr> </table> <p>This bit should always be set, except for test purposes. When this bit is set, setting REVWP or ADVWM has no effect. Hardware neither clears nor sets this bit. This bit can be set and cleared by firmware. This bit must always be set for isochronous endpoints (RXISO = 1).</p>	RX Status	Write Pointer	Write Marker	ACK	Unchanged	Advanced	NACK	Reversed	Unchanged
RX Status	Write Pointer	Write Marker									
ACK	Unchanged	Advanced									
NACK	Reversed	Unchanged									
1	ADVWM	<p>Advance Write Marker (Non-ARM Mode Only).* When set, the write marker is advanced to the origin of the next data set. Advancing the write marker is used for back-to-back receptions. Hardware clears this bit after the write marker is advanced. Setting this bit is effective only when the REVWP, ARM, and RXCLR bits are clear.</p>									
0	REVWP	<p>Reverse Write Pointer (Non-ARM Mode Only).* When set, the write pointer is returned to the origin of the last data set received, as identified by the write marker. The SIE can then reread the last data packet and write to the receive FIFO starting from the same origin when the host resends the same data packet. Hardware clears this bit after the write pointer is reversed. Setting this bit is effective only when the ADVWM, ARM, and RXCLR bits are clear.</p> <p>REVWP is used when a data packet is bad. When the function interface receives the data packet again, the write starts at the origin of the previous (bad) data set.</p>									

* ARM mode is recommended for normal operation. ADVWM and REVWP, which control the write marker and write pointer when ARM = 0, are used for test purposes.

Register Interface (continued)

Table 29. Receive FIFO Flag Register (RXFLG)—Address: 09H; Default: 0000 1000B

These flags indicate the status of the data packets in the receive FIFO specified by EPINDEX. This register is endpoint indexed.

Bit 7	Bit 6	Bit 5	Bit 4	Bit 3	Bit 2	Bit 1	Bit 0
RXFIF1	RXFIF0	—	RXFLUSH	RXEMP	RXFULL	RXURF	RXOVF
R		—	R	R		R/W	

Bit	Symbol	Function/Description																																																					
7:6	RXFIF[1:0]	<p>Receive FIFO Index Flags (Read Only). These read-only flags indicate which data packets are present in the receive FIFO (see below).</p> <p style="text-align: center;">Data Sets Present</p> <table border="1"> <thead> <tr> <th>RXFIF[1:0]</th> <th>ds1</th> <th>ds0</th> <th>Status</th> </tr> </thead> <tbody> <tr> <td>00</td> <td>No</td> <td>No</td> <td>Empty</td> </tr> <tr> <td>01</td> <td>No</td> <td>Yes</td> <td>1 set</td> </tr> <tr> <td>10</td> <td>Yes</td> <td>No</td> <td>1 set</td> </tr> <tr> <td>11</td> <td>Yes</td> <td>Yes</td> <td>2 sets</td> </tr> </tbody> </table> <p>The RXFIF bits are updated after each write to RXCNT to reflect the addition of a data packet. Likewise, the RXFIF bits are cleared in sequence after each setting of the RXFFRC bit. The next-state table for RXFIF bits is shown below for operation in dual-packet mode.</p> <table border="1"> <thead> <tr> <th>RXFIF[1:0]</th> <th>Operation</th> <th>Next RXFIF[1:0]</th> </tr> </thead> <tbody> <tr> <td>00</td> <td>Advance Write Marker</td> <td>01</td> </tr> <tr> <td>01</td> <td>Advance Write Marker</td> <td>11</td> </tr> <tr> <td>10</td> <td>Advance Write Marker</td> <td>11</td> </tr> <tr> <td>11</td> <td>Advance Write Marker</td> <td>11</td> </tr> <tr> <td></td> <td>Not Possible—Device will NACK any OUT.</td> <td></td> </tr> <tr> <td>00</td> <td>Set RXFFRC</td> <td>00</td> </tr> <tr> <td>01</td> <td>Set RXFFRC</td> <td>00</td> </tr> <tr> <td>11</td> <td>Set RXFFRC</td> <td>10/01</td> </tr> <tr> <td>10</td> <td>Set RXFFRC</td> <td>00</td> </tr> <tr> <td>00</td> <td>Reverse Write Pointer</td> <td>Unchanged</td> </tr> </tbody> </table> <p>When the receive FIFO is programmed to operate in single-packet mode (RXSPM set in EPCON), valid RXFIF states are 00 and 01 only.</p> <p>In isochronous mode, RXOVF, RXURF, and RXFIF are handled using the following rule: firmware events cause status change immediately, while USB events cause status change only at SOF. RXFIF is incremented by the USB and decremented by firmware. Therefore, setting RXFFRC decrements RFIIF immediately. However, a successful USB transaction within a frame increments RXFIF only at SOF.</p> <p>If MCSR.FEAT = 1: An old data set is flushed from an isochronous FIFO if it is not read out by firmware during the intended frame (see RXFLG.RXFLUSH description). This flush occurs at SOF, sets RXFLG.RXFLUSH, and causes RXFIF to decrement without firmware intervention.</p>	RXFIF[1:0]	ds1	ds0	Status	00	No	No	Empty	01	No	Yes	1 set	10	Yes	No	1 set	11	Yes	Yes	2 sets	RXFIF[1:0]	Operation	Next RXFIF[1:0]	00	Advance Write Marker	01	01	Advance Write Marker	11	10	Advance Write Marker	11	11	Advance Write Marker	11		Not Possible—Device will NACK any OUT.		00	Set RXFFRC	00	01	Set RXFFRC	00	11	Set RXFFRC	10/01	10	Set RXFFRC	00	00	Reverse Write Pointer	Unchanged
RXFIF[1:0]	ds1	ds0	Status																																																				
00	No	No	Empty																																																				
01	No	Yes	1 set																																																				
10	Yes	No	1 set																																																				
11	Yes	Yes	2 sets																																																				
RXFIF[1:0]	Operation	Next RXFIF[1:0]																																																					
00	Advance Write Marker	01																																																					
01	Advance Write Marker	11																																																					
10	Advance Write Marker	11																																																					
11	Advance Write Marker	11																																																					
	Not Possible—Device will NACK any OUT.																																																						
00	Set RXFFRC	00																																																					
01	Set RXFFRC	00																																																					
11	Set RXFFRC	10/01																																																					
10	Set RXFFRC	00																																																					
00	Reverse Write Pointer	Unchanged																																																					

Register Interface (continued)

Table 29. Receive FIFO Flag Register (RXFLG)—Address: 09H; Default: 0000 1000B (continued)

Bit	Symbol	Function/Description
7:6	RXFIF[1:0]	<p>Receive FIFO Index Flags (Read Only) (continued).</p> <p>For traceability, the RXFIF flags must be checked before and after reads from the receive FIFO and the setting of RXFFRC in RXCON.</p> <p>Note: To simplify firmware development, it is recommended that control endpoints are used in single-packet mode only.</p>
5	—	Reserved. Write 0s to these bits. Reads always return 0s.
4	RXFLUSH	<p>Receive FIFO Flush (Read Only). Only available if MCSR.FEAT = 1. Updated at every SOF, and only used for isochronous endpoints. RXFIF bits are set when valid data sets are received from the host. For isochronous endpoints, this RXFIF increment does not occur until the next SOF. During that subsequent frame, it is the responsibility of firmware to read out the data set. If that read is not completed (RXFFRC set by firmware) by the time the next SOF is received, that data set is flushed from the receive FIFO—RXFIF is decremented by hardware. This flush is indicated by hardware by setting the RXFLUSH bit. While this bit is set, the affect of firmware receive FIFO data (RXDAT) reads is blocked, in order to stop potential corruption of a new data set. Before firmware sets RXFFRC (for isochronous endpoints only), it must first check RXFLUSH. If RXFLUSH is set, firmware must discard the data set which it just read, because it is potentially corrupted. This situation should only occur if firmware is late in reading out a data set (read not completed before SOF). Firmware must not be late on consecutive frames—this will cause a loss of frame/data synchronization with the host—data sets may be visible to firmware during the wrong frame. Firmware must always set RXFFRC at the end of a data set read, even if RXFLUSH = 1. RXFLUSH is reset to 0 by the setting of RXFFRC to 1.</p>
3	RXEMP	<p>Receive FIFO Empty Flag (Read Only). Hardware sets this flag when there are no data bytes present in the data set currently being read. Hardware clears the bit when the empty condition no longer exists. This bit always tracks the current status of the receive FIFO, regardless of isochronous or nonisochronous mode.</p>
2	RXFULL	<p>Receive FIFO Full Flag (Read Only). Hardware sets this flag when the data set currently being read contains the same number of data bytes as the size of the FIFO. Hardware clears the bit when the full condition no longer exists. This bit always tracks the current status of the receive FIFO regardless of isochronous or nonisochronous mode.</p>
1	RXURF	<p>Receive FIFO Underrun Flag (Read, Clear Only). Hardware sets this bit when an additional byte is read from an empty receive FIFO or when RXCNTH or RXCNTL is read while RXFIF[1:0] = 00. Hardware does not clear this bit, so it must be cleared by firmware through RXCLR. When the receive FIFO underruns, the read pointer does not advance. It remains locked in the empty position.</p> <p>When this bit is set, all transmissions are NACKed.</p> <p>In isochronous mode, RXOVF, RXURF, and RXFIF are handled using the following rule: firmware events cause status change immediately, while USB events cause status change only at SOF. Since underrun can only be caused by firmware, RXURF is updated immediately. The RXURF flag must be checked after reads from the receive FIFO before setting the RXFFRC bit in RXCON.</p> <p>Note: When this bit is set, the FIFO is in an unknown state. It is recommended that the FIFO is reset in the error management routine using the RXCLR bit in the RXCON register.</p>

Register Interface (continued)

Table 29. Receive FIFO Flag Register (RXFLG)—Address: 09H; Default: 0000 1000B (continued)

Bit	Symbol	Function/Description
0	RXOVF	<p>Receive FIFO Overrun Flag (Read, Clear Only). This bit is set when the SIE writes an additional byte to a full receive FIFO or writes a byte count to RXCNT with RXFIF[1:0] = 11. This bit must be cleared by firmware through RXCLR, although it can be cleared by hardware if a SETUP packet is received after an RXOVF error has already occurred.</p> <p>When this bit is set, all transmissions are NACKed.</p> <p>In isochronous mode, RXOVF, RXURF, and RXFIF are handled using the following rule: firmware events cause status change immediately, while USB events cause status change only at SOF. Since overrun can only be caused by the USB, RXOVF is updated only at the next SOF regardless of where the overrun occurred during the current frame.</p> <p>Note: When this bit is set, the FIFO is in an unknown state. It is recommended that the FIFO is reset in the error management routine using the RXCLR bit in the RXCON register. When the receive FIFO overruns, the write pointer does not advance. It remains locked in the full position.</p>

Register Interface (continued)

Table 30. System Control Register (SCR)—Address: 11H; Default: 0000 0000B

This register controls the FIFO mode, IRQ mask, and IRQ mode selection.

Bit 7	Bit 6	Bit 5	Bit 4	Bit 3	Bit 2	Bit 1	Bit 0
IRQPOL	RWUPE	IE_SUSP	IE_RESET	SRESET	IRQLVL	T_IRQ	—
R/W							—

Bit	Symbol	Function/Description
7	IRQPOL	IRQ Polarity. Determines the polarity of the IRQN output. When asserted, the IRQN output is active-high (default is active-low). Firmware must be careful to ensure that setting this bit does not cause a false interrupt to be detected and processed.
6	RWUPE	Enable Remote Wake-Up Feature. When set, remote wake-up is enabled.
5	IE_SUSP	Enable Suspend Interrupt. When set, the SUSPEND interrupt is enabled.
4	IE_RESET	Enable Reset Interrupt. When set, the RESET interrupt is enabled.
3	SRESET	Software Reset. Setting this bit to 1 in software places the USS-820D in the RESET state. This is equivalent to asserting the hardware RESET pin, except that this feature is not available if the device is suspended. Setting this bit back to 0 leaves the USS-820D in an unconfigured state that follows a hardware reset. If MCSR.FEAT = 1, SSR.SUPPO = 0 and MCSR.SUSPLOE = 0: This bit may also be set to 1 while the device is suspended. The effect of this write is to wake up the device as if a remote wake-up had been performed, with the following exceptions: 1) Resume signaling is not transmitted to the host, 2) The feature is enabled regardless of the SCR.RWUPE setting, and 3) The MCSR.RWUPR register bit does not set. The actual setting of the SCR.SRESET register bit does not occur until the device is resumed and internal clocks are enabled, but the wake-up is initiated immediately. Once the wake-up is complete, the SRESET bit sets, and the behavior is the same as if SRESET had been set while the device was awake. Since the host will still expect the device to be suspended, this feature should not be used with bus-powered devices, since the device will exceed the suspend power requirement.
2	IRQLVL	Interrupt Mode. Level mode interrupt is selected when this bit is cleared. Pulse mode interrupt is selected when this bit is set. In pulse mode, IRQ signal is driven (high or low, depending on the IRQPOL setting) by USS-820D for two tCLK periods.
1	T_IRQ	Global Interrupt Enable. When this bit is set, it enables hardware interrupt to be generated on IRQ pin when any of TX/RX bits, ASOF bit, RESET bit, or SUSPEND bit is set.
0	—	Reserved. Write 0 to this bit. Reads always return 0.

Register Interface (continued)

Table 31. System Status Register (SSR)—Address: 12H; Default: 0000 0000B

This register allows control and monitoring of the USB suspend and reset events.

Bit 7	Bit 6	Bit 5	Bit 4	Bit 3	Bit 2	Bit 1	Bit 0
—			SUSPPO	SUSPDIS	RESUME	SUSPEND	RESET
—			R/W (P*)			R	W (P*)

Bit	Symbol	Function/Description
7:5	—	Reserved. Write 0s to these bits. Reads always return 0s.
4	SUSPPO	Suspend Power Off. This bit must be set by firmware if externally connected devices will be powered off during a suspend. The correct value of this bit must be established before firmware suspends the USS-820D and should only need to be done once at device initialization time.
3	SUSPDIS	Suspend Disable. When asserted, this bit disables the detection of a USB suspend event. This bit is for test purposes and should not be set during normal system operation.
2	RESUME	Resume Detected. For a complete description of the use of this bit, see the Suspend and Resume Behavior section of this document. When set, the USS-820D has detected and responded to a wake-up condition, either global or remote. A global resume is indicated when the host asserts a non-IDLE state on the USB bus. A remote wake-up is indicated when the device asserts the RWUPN input pin (if that feature is enabled by the RWUPE bit). This bit should be reset by firmware as soon as possible after resuming to allow the next suspend event to be detected.
1	SUSPEND	Suspend Detected (Read Only)/Suspend Control (Write Only). For a complete description of the use of this bit, see the Suspend and Resume Behavior section of this document. This bit serves as both a read-only status bit and a write-only control bit. For this reason, firmware cannot do a simple read/modify/write sequence to update this register. Firmware must always explicitly specify the correct value of this SUSPEND control bit when writing SSR. The read-only status bit is set by hardware when a SUSPEND condition is detected on the USB bus, and clears itself after the SUSPEND condition ceases and the device resumes. The bit will remain set during device wake-up. The value of this read-only bit is not affected by firmware writes. The write-only control bit is only updated by firmware, and is used to suspend the device by setting the bit to 1, and then setting the bit to 0. This write sequence will cause the device to suspend regardless of the initial value of the bit, which cannot be read.
0	RESET	USB Reset Detected. When set, a RESET condition is detected on the USB bus. If interrupt is enabled (T_IRQ and IE_RESET set), an interrupt is generated to the controller. Firmware clears this bit.

* S = shared bit. P = PEND must be set when writing this bit. See Special Firmware Action for Shared Register Bits section.

Table 32. Hardware Revision Register (REV)—Address: 18H; Default: 0001 0011B

This register contains the hardware revision number, which will be incremented for each version of the hardware. This will allow firmware to query the hardware status and determine which functions or features are supported.

Bit 7	Bit 6	Bit 5	Bit 4	Bit 3	Bit 2	Bit 1	Bit 0
Main Hardware Revision Number				Sub Hardware Revision Number			
R							

Bit	Symbol	Function/Description
7:4	—	Main Hardware Revision Number.
3:0	—	Sub Hardware Revision Number.

Register Interface (continued)

Table 33. Suspend Power-Off Locking Register (LOCK)—Address: 19H; Default: 0000 0001B

This register contains the control and status which enables the USS-820D locking mechanism. This feature protects the internal register set from being corrupted during and immediately after a suspend where the external controller is powered off. The feature is enabled by the SUSPLOE bit, and its proper usage is documented in the *Special Action Required by USS-820/USS-825 After Suspend Application Note (AP97-058CMPR-04)*.

Bit 7	Bit 6	Bit 5	Bit 4	Bit 3	Bit 2	Bit 1	Bit 0
—							UNLOCKED
—							R/W

Bit	Symbol	Function/Description
7:1	—	Reserved.
0	UNLOCKED	Locking Control/Status. Use of this bit is described in the <i>Special Action Required by USS-820/USS-825 After Suspend Application Note (AP97-058CMPR-04)</i> .

Table 34. Pend Hardware Status Update Register (PEND)—Address: 1AH; Default: 0000 0000B

This register contains the PEND bit.

Bit 7	Bit 6	Bit 5	Bit 4	Bit 3	Bit 2	Bit 1	Bit 0
—							PEND
—							R/W

Bit	Symbol	Function/Description
7:1	—	Reserved.
0	PEND	Pend. When set, this bit modifies the behavior of other shared register bits. See the Special Firmware Action for Shared Register Bits section of this document for a detailed explanation.

Table 35. Scratch Firmware Information Register (SCRATCH)—Address: 1BH; Default: 0000 0000B

This register contains a 7-bit scratch field that can be used by firmware to save and restore information. One possible use would be to save the device's USB state (e.g., DEFAULT, ADDRESSED) during suspend power off. The register also contains the resume interrupt enable bit.

Bit 7	Bit 6	Bit 5	Bit 4	Bit 3	Bit 2	Bit 1	Bit 0
IE_RESUME	SCRATCH						
R/W	R/W						

Bit	Symbol	Function/Description
7	IE_RESUME	Enable Resume Interrupt. When set, the RESUME interrupt is enabled.
6:0	SCRATCH	Scratch Information.

Register Interface (continued)

**Table 36. Miscellaneous Control/Status Register (MCSR)—Address: 1CH; Default:
0000 0000B (44-Pin MQFP—USS-820D)
0001 0000B (48-Pin TQFP—USS-820TD)**

This register contains miscellaneous control and status bits.

Bit 7	Bit 6	Bit 5	Bit 4	Bit 3	Bit 2	Bit 1	Bit 0
RWUPR	INIT	SUSPS	PKGID	FEAT	BDFEAT	SUSPLOE	DPEN
R	R	R	R	R/W	R/W	R/W	R/W

Bit	Symbol	Function/Description
7	RWUPR	Remote Wake-Up Remember. This bit is only available if MCSR.FEAT = 1; otherwise, it always reads 0. Updated by hardware on each wake-up from a suspended state. This bit is set to 1 if the wake-up was caused by a remote wake-up event (RWUPN pin asserted). Otherwise, it is reset to 0 (on a global resume or USB reset). If RWUPN is asserted simultaneously with a global wake-up, the bit is reset to 0 (global wake-up wins). When set, this bit indicates that resume signaling will be transmitted upstream.
6	INIT	Device Initialized. This bit will read 0 until internal clocks are turned on after a hardware reset. This bit is not affected by software reset. This bit can be used by firmware to determine when the device is operational after a hardware reset.
5	SUSPS	Suspend Status. Indicates the current suspended status of the device. This bit will be set when the device goes suspended and will remain set until internal clocks are turned back on at the end of a resume sequence.
4	PKGID	Package Identification. Indicates the package type. This bit will read 0 for the 44-pin MQFP package (USS-820D) and 1 for the 48-pin TQFP package (USS-820TD). This value is established at the end of a hardware reset sequence.
3	FEAT	Feature Enable. When set, this bit enables various features introduced in revision C of the USS-820C. This bit controls those features which do not impact existing circuit boards using the USS-820 revision B (i.e., those features not enabled by MCSR.BDFEAT). These features are explained in detail in the Appendix C of the data sheet. When reset to 0 (along with MCSR.BDFEAT, TXSTAT.TXDSAM and TXSTAT.TXNAKE), the device will behave like revision B.
2	BDFEAT	Board Feature Enable. When set, this bit enables various features introduced in revision C of the USS-820C. This bit controls those features which could be incompatible with existing circuit boards using the USS-820 revision B. These features are explained in detail in Appendix C of the data sheet. When reset to 0 (along with MCSR.FEAT, TXSTAT.TXDSAM and TXSTAT.TXNAKE), the device will behave like revision B.
1	SUSPLOE	Suspend Lock Out Enable. Enables the device locking mechanism, which will then engage on every device resume. The correct value of this bit must be established before firmware suspends the device.
0	DPEN	DPLS Pull-Up Enable. Controls the DPPU output pin, which may be used to power the external DPLS pull-up resistor. This can be used by firmware to make the device appear disconnected from the host without a physical disconnect. When DPEN = 1, the DPPU output pin is driven high. When DPEN = 0, the DPPU output pin is 3-stated.

Register Interface (continued)

Table 37. Data Set Available (DSAV)—Address: 1DH; Default: 0000 0000B

This register contains receive/transmit data set available bits.

Bit 7	Bit 6	Bit 5	Bit 4	Bit 3	Bit 2	Bit 1	Bit 0
RXAV3	TXAV3	RXAV2	TXAV2	RXAV1	TXAV1	RXAV0	TXAV0
R	R	R	R	R	R	R	R

Bit	Symbol	Function/Description
7	RXAV3	Receive/Transmit Data Set Available. This feature is only available if MCSR.FEAT = 1 or TXDSAM = 1; otherwise, reads 0. May be used to improve firmware efficiency when polling endpoints. For receive FIFOs, this register indicates that one or more data sets are available to be read. For transmit FIFOs, this register indicates that one or more data sets are available to be written. Bits always read 0 for endpoints which are not enabled (RXEPEN/TXEPEN = 0). If a transmit endpoint has TXDSAM = 1, the corresponding RXAV/TXAV bit of the DSAV register indicates instead that the TXVOID bit is set (a NAK has been sent to the host). This usage when TXDSAM = 1 does not require MCSR.FEAT = 1.
6	TXAV3	
5	RXAV2	
4	TXAV2	
3	RXAV1	
2	TXAV1	
1	RXAV0	
0	TXAV0	

Table 38. Data Set Available (DSAV1)—Address: 1EH; Default: 0000 0000B

This register contains receive/transmit data set available bits.

Bit 7	Bit 6	Bit 5	Bit 4	Bit 3	Bit 2	Bit 1	Bit 0
RXAV7	TXAV7	RXAV6	TXAV6	RXAV5	TXAV5	RXAV4	TXAV4
R	R	R	R	R	R	R	R

Bit	Symbol	Function/Description
7	RXAV7	Receive/Transmit Data Set Available. This feature is only available if MCSR.FEAT = 1 or TXDSAM = 1; otherwise, reads 0. May be used to improve firmware efficiency when polling endpoints. For receive FIFOs, this register indicates that one or more data sets are available to be read. For transmit FIFOs, this register indicates that one or more data sets are available to be written. Bits always read 0 for endpoints which are not enabled (RXEPEN/TXEPEN = 0). If a transmit endpoint has TXDSAM = 1, the corresponding RXAV/TXAV bit of the DSAV register indicates instead that the TXVOID bit is set (a NAK has been sent to the host). This usage when TXDSAM = 1 does not require MCSR.FEAT = 1.
6	TXAV7	
5	RXAV6	
4	TXAV6	
3	RXAV5	
2	TXAV5	
1	RXAV4	
0	TXAV4	

Interrupts

Figure 8 describes the device interrupt logic. Each of the indicated USB events are logged in a status register bit. Each status bit has a corresponding enable bit that allows the event to cause an interrupt. Interrupts can be masked globally by the T_IRQ bit of the SCR register. The active level and signaling mode (level vs. pulse) of the IRQN output pin can be controlled by the IRQPOL and IRQLVL bits of the SCR register. All interrupts have equal priority—firmware establishes its own priority by the order in which it checks these status bits during interrupt processing.

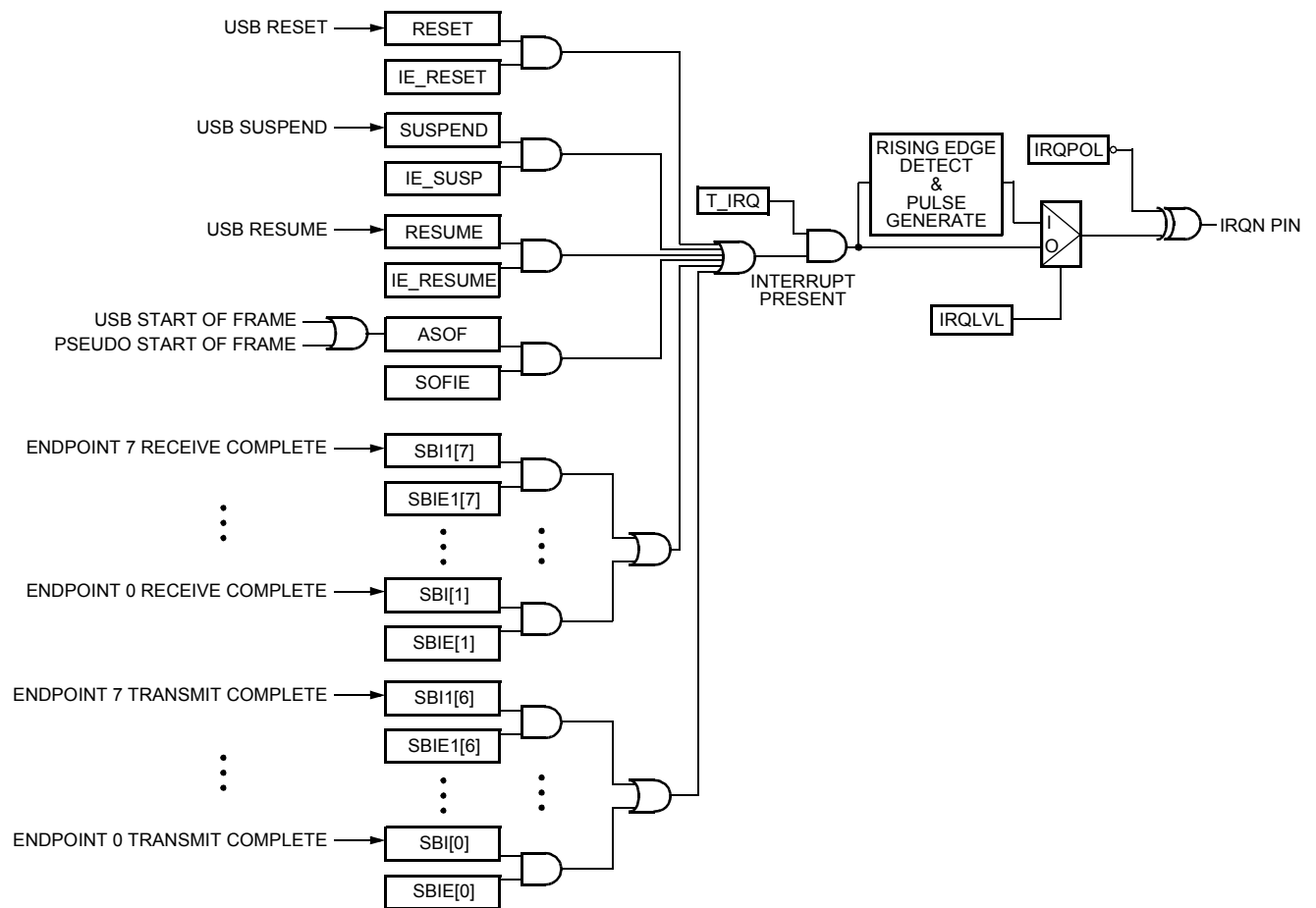

5-6402

Figure 8. USS-820D Interrupts

Firmware Responsibilities for USB SETUP Commands

All SETUP commands are passed through from the USB host to the corresponding receive FIFO (assuming no data transfer errors). Firmware must interpret and execute each command according to its USB definition.

Reception of a new SETUP command can be identified by the RXSETUP bit being set when a receive interrupt is generated. Any old data in the receive FIFO is overwritten by a new SETUP command. The STOVW register bit is set by hardware when a new SETUP packet is detected. When the complete SETUP packet has been written, hardware resets the STOVW bit and sets the EDOVW bit. If either the STOVW or EDOVW bit is set, the effect of any firmware actions on the FIFO pointers is blocked. This prevents the FIFO from underflowing as a result of firmware attempting to read the FIFO while hardware is writing a new setup packet. Firmware must reset the EDOVW bit, read the SETUP command from the FIFO, and then check the STOVW and EDOVW bits. If either is set, the SETUP that was just read out is old and should be discarded. Firmware must then proceed with reading the new SETUP command.

Firmware responsibilities for interpreting and executing USB standard commands are defined in Table 39.

Table 39. Firmware Responsibilities for USB SETUP Commands

USB Command	Firmware Responsibility
GET_STATUS	<p>For device status, firmware should write two data bytes to transmit FIFO 0, where bit 0 of byte 0 indicates if the device is self-powered, and bit 1 indicates if the remote wake-up feature is supported (which should equal the value stored in the RWUPE register bit).</p> <p>For interface status, firmware should write two data bytes of zeros.</p> <p>For endpoint status, firmware should write two data bytes to transmit FIFO 0, where bit 0 of byte 0 is the RXSTL or TXSTL bit of the endpoint indicated by the SETUP command.</p>
SET/CLEAR_FEATURE	<p>For the DEVICE_REMOTE_WAKEUP feature, firmware should set/reset the RWUPE register bit.</p> <p>For the ENDPOINT_STALL feature, firmware should set/clear the RXSTL or TXSTL register bit indicated by the SETUP command. Firmware must also handle all side effects of these commands as documented in the USB specification, such as zeroing an endpoint's data toggle bit on CLEAR_FEATURE[stall].</p>
SET_ADDRESS	Firmware should write the FADDR register with the device address indicated by the SETUP command. This write must not occur until after the status stage of the control transfer has completed successfully.
GET_CONFIGURATION, SET_CONFIGURATION, GET_INTERFACE, SET_INTERFACE	Firmware must maintain all information regarding which endpoints, interfaces, alternate settings, and configurations are supported and/or currently enabled. The enabled status of a particular endpoint direction, as specified by the current configuration, interface, and alternate setting, must be indicated in the corresponding RXEPEN or TXEPEN register bit. Firmware must also handle any side effects of these commands as documented in the USB specification, such as zeroing an endpoint's stall and data toggle bits on SET_INTERFACE or SET_CONFIGURATION.
GET_DESCRIPTOR, SET_DESCRIPTOR	Firmware must maintain all information regarding all types of descriptors and write the appropriate descriptor information to transmit FIFO 0 upon receiving GET_DESCRIPTOR, or read the appropriate descriptor information from receive FIFO 0 upon receiving SET_DESCRIPTOR.

Firmware Responsibilities for USB SETUP Commands (continued)

Firmware must keep track of the direction of data flow during a control transfer, and detect the start of the status stage by a change in that direction. For control OUT transfers, the status stage will be an IN, and the firmware should write a zero-byte data packet to the transmit FIFO, assuming the command completed successfully. For control IN transfers, the status stage will be an OUT, and the firmware should read the data packet and set the RXFFRC register bit (like any other OUT transfer), again assuming the command completed successfully. This will cause an ACK to be sent to the host, indicating a successful completion.

Firmware should stall endpoint 0 if it receives a standard command that does not match any of the defined commands or a valid command that contains a parameter with a bad value (e.g., GET_STATUS[Endpoint x] when endpoint x is not enabled). Firmware should also stall if the data stage of a control transaction attempts to transfer more bytes than were indicated by the SETUP stage.

Firmware must interpret any vendor or class commands as defined by the application.

Other Firmware Responsibilities

Table 40. Other Firmware Responsibilities

USB Event	Firmware Responsibility
USB Reset	USB reset can be detected by reading a 1 from the RESET bit of the SSR register. If the USB interrupt is enabled (IE_RESET), this will be indicated by the IRQN output. At that time, firmware must reset any information it maintains regarding endpoints, interfaces, alternate settings, and configurations. All RXEPEN and TXEPEN endpoints should be set to 0, except for endpoint 0, which should be set to 1. The function address register FADDR should be set to 0. The data toggle bits for all endpoints should be set to 0 as well. If MCSR.FEAT = 1, FADDR is automatically cleared to 0 when USB reset is detected.
USB Suspend and Resume	Firmware must manage the SUSPEND and RESUME register bits, as documented in the following section, in order to meet the USB specifications for bus-powered devices.

Frame Timer Behavior

The USS-820D contains an internal frame timer that allows the device to lock to the USB host frame timer, and to synthesize lost SOF packets, as required by the USB specification. The frame timer requires three valid SOF packets from the host in order to lock to the host frame timer. This locked status is indicated by the FTLOCK status bit in SOFH. In order to achieve this lock, the interval between each SOF must be within 45 clocks of the nominal 12,000 clocks, and the successive intervals must be within two clocks of each other. Both of these conditions will be true in a correctly functioning system with no bus errors. While the frame timer is locked, it will synthesize SOFs by setting ASOF, generating an SOF interrupt (if SOFIE = 1), and asserting the SOFN pin (if SOFODIS = 0) for up to three consecutive frames if SOF packets are no longer received from the host. The frame timer will become unlocked under any of the following conditions:

- Hard or soft reset.
- USB reset.
- The device goes suspended.
- No SOF packets are received from the host for three frames.
- An SOF is received that violates the USB specification for frame interval or previous frame length comparison.

Suspend and Resume Behavior

Note: In the following sections describing suspend and resume behavior, the following terminology is used:

- Device—The entire product that contains the USS-820D, such as a modem or printer.
- Application—All electronic components of the device other than the USS-820D, such as a microcontroller, RAM, power control logic, reset logic, or crystal.
- Firmware—Code running on the microcontroller which is part of the application.
- Controller—That intelligent part of the application which uses the USS-820D address, data and read/write pins to access its internal registers.
- Powered-off components—Those parts of the application which are connected to the USS-820D and powered off during suspend, for example, a microcontroller or RAM.
- Hardware—Logic inside the USS-820D.

Suspend and Resume Behavior

(continued)

During a suspend/resume sequence, the following sequence of events occurs:

1. **Hardware Suspend Detect:** The USS-820D detects a suspend request from the host on USB and notifies firmware.
2. **Firmware Suspend Initiate:** Firmware reacts to the pending suspend request and suspends the device.
3. **Hardware Resume Detect/Initiate:** Some time later a resume is initiated, either by the host or the application.
4. **Hardware Resume Sequence:** When the resume is complete, the USS-820D notifies firmware.
5. **Firmware Resume Sequence:** Firmware reacts to the resume and completes any required actions.

The following sections describe each of these steps in more detail.

Hardware Suspend Detect

The USS-820D detects a USB suspend condition if a J state persists on the bus for at least 3 ms. When this suspend condition is detected, hardware sets the SSR.SUSPEND register status bit and, if IE_SUSP = 1, causes an interrupt.

Suspend detection may be blocked by firmware by setting the SSR.SUSPDIS register bit to 1. SSR.SUSPDIS should only be set for test purposes, never in a running system.

Firmware Suspend Initiate

When firmware detects that a suspend request from the host has been detected, it must prepare itself, and any other application components for which it is responsible, for suspend mode. For bus-powered devices, this will normally require turning off power to application components or placing them in low-power mode. When firmware is finished preparing for a device suspend, it should check the SSR.SUSPEND register status bit once more. If this status bit has reset, firmware should abort the suspend sequence, since the host has already awakened the device. This will only happen if firmware is too slow in responding to the suspend detect. If the status bit is still set, firmware should proceed with the suspend sequence. This second check of the status bit guarantees that the device will see wake-up signaling of sufficient length from the host.

To suspend the USS-820D, firmware must set the SSR.SUSPEND register control bit to 1, and then reset the bit to 0. This action causes the USS-820D to immediately enter suspend mode.

In order to guarantee correct behavior when resuming, firmware must not attempt any register reads until at least three tRDREC periods have elapsed since resetting the SSR.SUSPEND register control bit.

Since firmware must have the PEND register bit set when modifying the SSR.SUSPEND register bit, and since registers cannot be written while the USS-820D is suspended, firmware must remember to reset the PEND register bit after the USS-820D resumes.

Since the SSR.SUSPEND register status bit will remain set while the USS-820D is suspended, a pending SUSPEND interrupt will remain until the USS-820D resumes. For this reason, firmware may wish to reset the SCR.IE_SUSP bit before suspending the USS-820D.

In order to meet the USB specification's current draw limit for suspended devices, the USS-820D must turn off its internal clocks. This occurs when the SSR.SUSPEND register control bit is reset by firmware as described above and is indicated by the USS-820D SUSPN output pin being asserted. While in suspend mode, the USS-820D must remain powered, but the USS-820D's power consumption will be reduced to almost zero and will remain in this state until a wake-up is signaled.

Self-powered devices will most likely not need to turn off power to other application components during suspend. This is indicated to the USS-820D by the SSR.SUSPPO register bit = 0, which should be written by firmware at device initialization time. In such an environment, during suspend, the USS-820D outputs and inputs continue to be driven by the USS-820D and the application, respectively. In addition, the USS-820D bidirectional pins are 3-stated in the USS-820D and driven to 0 or 1 by the application.

Bus-powered devices will most likely need to turn off power to other application components during suspend. This is indicated to the USS-820D by the SSR.SUSPPO register bit = 1, which should be written by firmware at device initialization time. Such devices can be implemented so that the USS-820D SUSPN output pin controls power to other application components. Issues which must be considered by bus-powered devices are discussed in the Special Suspend Considerations for Bus-Powered Devices section.

Suspend and Resume Behavior

(continued)

Firmware Suspend Initiate (continued)

While the USS-820D is suspended, its internal registers may still be read, presumably only in self-powered devices. The interface timing for such reads is different from register reads during operational mode, and is specified in the Register Timing Characteristics section. Register writes must not be attempted while the USS-820D is suspended, with the possible exception of the SCR.SRESET bit (see the SCR.SRESET description for details). Certain register reads during the nonsuspended state can cause USS-820D device register states to change. These reads are described in the Register Reads with Side Effects section. These register reads must not be attempted while the USS-820D is suspended.

Hardware Resume Detect/Initiate

Wake-up can be initiated by either the host or the application. A host-signaled wake-up (global resume) is indicated when the host drives a K state on the USB bus. A remote wake-up is initiated by the application by asserting the USS-820D RWUPN input pin. The USS-820D can also be awakened by firmware writing a 1 to SCR.SRESET if MCSR.FEAT = 1 (see SCR.SRESET description for details). In these cases, the USS-820D will initiate a wake-up sequence as described in the next section.

Hardware Resume Sequence

The USS-820D starts a wake-up sequence by asynchronously re-enabling its internal oscillator and PLL and deasserting the SUSPN output pin. Once the internally generated clocks are stable (a period of 6 ms to 15 ms), then it enables clocks to the entire chip and sets the SSR.RESUME register bit, which causes an interrupt if SCRATCH.IE_RESUME register bit = 1. The USS-820D will require up to 15 ms to resume functionality after a wake-up sequence is initiated. If the wake-up was a remote wake-up, the USS-820D will then drive wake-up signaling (K) on the USB for 12 ms.

The USS-820D requires a minimum of 7 ms from the time a remote wake-up is initiated to the time it can begin transmitting resume signaling upstream. This guarantees adherence to the USB specification for tWTRSM of 5 ms.

Firmware Resume Sequence

The USS-820D indicates that the resume sequence is complete by setting the SSR.RESUME register bit, and possibly causing an interrupt. When firmware is prepared for the application to return to normal operation, it must reset the SSR.RESUME register bit to allow detection of any subsequent suspend events.

Special Suspend Considerations for Bus-Powered Devices

In order to meet the USB current requirements while suspended, care must be exercised to guarantee that all board signals connected to the USS-820D are at their proper state. Voltages on USS-820D input pins must be guaranteed to be outside the switching threshold region (i.e., either a valid CMOS logic 1 or 0). Pins that are connected to external, powered-off components must not be driven high.

If an external oscillator is used as the clock source for the USS-820D, it will most likely need to be turned off by the USS-820D SUSPN output pin in order to meet the USB suspend current requirement. When the oscillator is turned back on after a resume (when the SUSPN pin deasserts) and is stabilizing (a period that must not exceed t_{OSC} as specified in Table 46), its output clock must not have a frequency greater than 12 MHz. As a result, during this stabilization period, the oscillator output must not provide more than 84,000 clocks.

The following list describes the expected (or required, as noted) values on the USS-820D pins for devices which turn power off to external components during suspend. Such devices must have SSR.SUSPPO = 1 to cause D[7:0], IRQN, and SOFN to be 3-stated during suspend. They must also have MCSR.BDFEAT = 0 while suspended in order to guarantee that USBR and DSA are 3-stated. These register settings avoid the possibility of driving a logic 1 into a powered-off component, which could result in excessive power consumption and possible component damage.

External logic refers to components external to the USS-820D.

Note: Board signals which are connected to powered-off components will most likely be naturally pulled to logic 0 by the powered-off component.

- A[4:0], IOCSN, RDN, WRN: Input-only pins. Their value will be determined by external logic, and must be a logic 0 or 1 to avoid current draw in the USS-820D.

Suspend and Resume Behavior

(continued)

Special Suspend Considerations for Bus-Powered Devices (continued)

- D[7:0], SOFN*: Bidirectional pins, forced to input mode while suspended (assuming SSR.SUSPPO = 1). Their value will be determined by external logic, and must be a logic 0 or 1 to avoid current draw in the USS-820D.
- IRQN, USBR, DSA: 3-statable outputs, forced to 3-state during suspend (assuming SSR.SUSPPO = 1, MCSR.BDFEAT = 0). Their value will be determined by external logic, and is a don't care for the USS-820D.
- DPLS, DMNS: Bidirectional pins, in input mode during suspend, driven by USB. Since they are statically driven to 1 and 0, respectively, there is no current draw in the USS-820D.
- RWUPN: Input-only pin, driven to 1 by (powered) external logic during suspend, unless/until a remote wake-up is signalled.
- SUSPN: Output-only pin, driven to 0 by USS-820D to indicate suspend.
- XTAL1: Input connection to internal oscillator. If a crystal is used as a clock source, there are no special considerations for this pin. If an external oscillator is used as a clock source, this input must be driven to a stable 1 by external logic.
- RESET: Driven to 0 during suspend by external logic.
- DPPU: 3-statable output, drives a logic 1 during sus-

pend (assuming MCSR.DPEN = 1). This is required in case the pin is used to power the external DPLS pull-up resistor, which must remain powered during suspend.

Depending on the device design, the USS-820D register interface signals (RDN, WRN, IOCSN) could have unknown values immediately after a suspend because external components have been powered off. In this case, firmware must configure the USS-820D to enable the locking mechanism by setting the MCSR.SUSPLOE register bit. This mechanism protects the internal registers from being corrupted in this situation. Its behavior is documented in *Special Action Required by USS-820/USS-825 After Suspend* Application Note (AP97-058CMR-04).

* SOFN is an output-only pin during normal operation. In certain chip test modes, this pin functions as an input.

Application Notes

1. The RESET input must remain asserted for a minimum period of time after power is stable. If internal oscillator clocking mode is used, this time is t_{OSC} , the amount of time required to allow the internal oscillator output to become stable. If external oscillator clocking mode is used, this time is t_{RST} . The USS-820D WRN and RWUPN pins must not both be active (low) at the time that the RESET input is deasserted.
2. After changing the size (RXFFSZ/TXFFSZ), type (isochronous vs. nonisochronous), enabled status (RXEPEN/TXEPEN) of a FIFO/endpoint or chip features (FEAT, BDFEAT), firmware must guarantee that at least 16 tCLK periods have elapsed before attempting to access the FIFO data. This is required to allow the internal FIFO RAM to be reallocated.
3. Register writes are triggered by the rising edge of either WRN or IOCSN, whichever comes first, and are synchronized to the internal 12 MHz clock. Therefore, the actual write may not occur until as much as tCLK ns after that first rising edge. This latency must be taken into account when performing subsequent register reads or writes.
4. The IRQN and SOFN pins require external pull-ups or pull-downs if the external controller will be powered off during suspend. In that situation, those pins will be 3-stated until the USS-820D has fully resumed. The pull-up or pull-down is needed to establish the desired level at the controller for the time interval from when the controller is powered on to the time when the USS-820D has completed the resume. The same requirements hold for the USBR and DSA outputs if they are connected to devices that will be powered off during suspend.
5. In applications where the external controller is powered off during suspend (firmware has set SSR.SUSPPO), the SOFN pin must be connected to an external pull-down even if the pin is not functionally required. The pin is actually bidirectional, where the input mode is only used in chip test modes. The pull-down is required to avoid excessive power consumption by the input stage when the device is suspended.

1394 Application Support Contact Information

E-mail: 1394support@agere.com

Absolute Maximum Ratings

Stresses in excess of the absolute maximum ratings can cause permanent damage to the device. These are absolute stress ratings only. Functional operation of the device is not implied at these or any other conditions in excess of those given in the operations sections of this data sheet. Exposure to absolute maximum ratings for extended periods can adversely affect device reliability.

Table 41. Absolute Maximum Ratings

Parameter	Symbol	Min	Max	Unit
Ambient Operating Temperature Range	T_A	-20	85	°C
Storage Temperature	T_{stg}	-40	125	°C
Power Supply Voltage with Respect to Ground	VDD	—	4.2	V

Table 42. Absolute Maximum Voltage Ratings ($0\text{ }^{\circ}\text{C} \leq T_A \leq 85\text{ }^{\circ}\text{C}$)

Parameter	Symbol	Min	Max	Unit
Voltage on Any Non-USB Pin with Respect to Ground	—	$V_{SS} - 0.3$	5.5	V

Table 43. Absolute Maximum Voltage Ratings ($-20\text{ }^{\circ}\text{C} \leq T_A \leq 0\text{ }^{\circ}\text{C}$)

Parameter	Symbol	Min	Max	Unit
Persistent* Voltage on Any Non-USB Pin with Respect to Ground	—	$V_{SS} - 0.3$	3.6	V
Non-persistent* Voltage on Any Non-USB Pin with Respect to Ground	—	$V_{SS} - 0.3$	5.5	V

* A persistent voltage level is considered to be one which lasts for more than 25 ns.

Electrical Characteristics

dc Characteristics

Table 44. dc Characteristics ($T_A = 0\text{ }^\circ\text{C}$ to $85\text{ }^\circ\text{C}$, $V_{DD} = 3.3\text{ V} \pm 0.165\text{ V}$, $V_{SS} = 0\text{ V}$)

Parameter	Symbol	Test Conditions	Min	Typ	Max	Unit
USB Signals						
High-Z State Data Line Leakage	I _{LO}	0 V < V _{IN} < 3.3 V	-10	—	10	μA
Differential Receiver: Common-mode Range	CMR	—	0	—	V _{DD}	V
Sensitivity	V _{DI}	CMR = 0.8 V to 2.5 V	0.2	—	—	V
Single-ended Receiver: Low	V _{IL}	—	—	—	0.8	V
High	V _{IH}	—	2.0	—	—	V
Hysteresis	V _H	—	0.3	—	—	V
Output Voltage: Low	V _{OL}	RL of 1.5 kΩ to 3.6 V	—	—	0.3	V
High	V _{OH}	RL of 15 kΩ to GND	2.8	—	3.465	V
Transceiver Capacitance	C _{IN}	Pin to GND	—	—	20	pF
Other Signals						
Hysteresis (RESET and RWUPN only)	V _H	—	0.3	—	—	V
Input Voltage: Low	V _{IL}	—	—	—	0.8	V
High	V _{IH}	—	2.0	—	—	V
Output Voltage (SUSPN, IRQN, USBR, DSA): Low	V _{OL}	I _{OL} = 6 mA	—	—	0.4	V
High	V _{OH}	I _{OL} = -6 mA	2.4	—	V _{DD}	V
High	V _{OH}	I _{OL} = -1 mA	V _{DD} - 0.15	—	V _{DD}	V
Output Voltage (D[7:0], SOFN, DPPU): Low	V _{OL}	I _{OL} = 10 mA	—	—	0.4	V
High	V _{OH}	I _{OL} = -10 mA	2.4	—	V _{DD}	V
High	V _{OH}	I _{OL} = -1 mA	V _{DD} - 0.1	—	V _{DD}	V
Device						
Total Supply Current: Configured	I _D	—	—	20	30	mA
Preconfigured	I _{DP}	—	—	17	20	mA
Suspended	I _{DS}	—	—	2	10	μA
Power Supply Voltage	V _{DD} , V _{DDA} , V _{DDT}	—	3.135	3.3	3.465	V
Leakage Current (D[7:0], SOFN)	—	V _{IN} ≤ 1.4 V	-10	—	10	μA
	—	2.7 V ≤ V _{IN} ≤ 5.5 V	-10	—	10	μA
Leakage Current (USBR, DSA, DPPU)	—	0 V ≤ V _{IN} ≤ 5.5 V	-10	—	10	μA
Leakage Current (XTAL1, A[4:0], RWUPN, IRQN, RESET, IOCSN, RDN, WRN)	—	V _{IN} ≤ 1.4 V	-1	—	1	μA
	—	2.7 V ≤ V _{IN} ≤ 5.5 V	-1	—	1	μA

Note: These parameters may vary slightly when operating at ambient temperatures below 0 °C.

Electrical Characteristics (continued)

Power Considerations

The USB specification places current limits on bus-powered devices. The limit is tighter for a device that has not yet been configured. The tightest limit is for a suspended device.

The current values listed in Table 44 for a preconfigured device assume fairly low activity (about 5%) on USB. The maximum value for a configured device assumes the device is transmitting 80% of the time on USB. All current values assume a 35 pF load on the package pins.

The limit for suspended devices can only be met if careful measures are taken to control the interface to the USS-820D, as documented in the Suspend and Resume Behavior section.

USB Transceiver Driver Characteristics

Table 45. USB Transceiver Driver Characteristics

Parameter	Symbol	Test Conditions	Min	Max	Unit
Rise and Fall Times: (10%—90%)	t _R	OEN = 0, C _L = 50 pF	4	20	ns
(90%—10%)	t _F	OEN = 0, C _L = 50 pF	4	20	ns
Rise/Fall Time Matching	t _{RFM}	OEN = 0, C _L = 50 pF	90	110	%
Crossover Point	V _{CRS}	OEN = 0, C _L = 50 pF	1.3	2.0	V
Output Impedance*	Z _{DRV}	OEN = 0	28	43	Ω

* At steady-state drive, when used with an external series resistor of 24 Ω.

Electrical Characteristics (continued)

Connection Requirements

USB Transceiver Connection

The physical connection of the USS-820D to the USB bus requires only minimal components to provide proper USB electrical terminations.

Both DPLS and DMNS require $24 \Omega \pm 1\%$ series resistors for USB impedance matching. Additionally, a $1.5 \text{ k}\Omega$ pull-up resistor is required on DPLS for full-speed/low-speed differentiation.

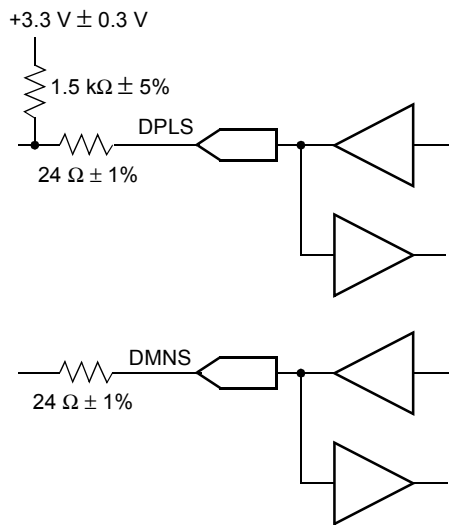
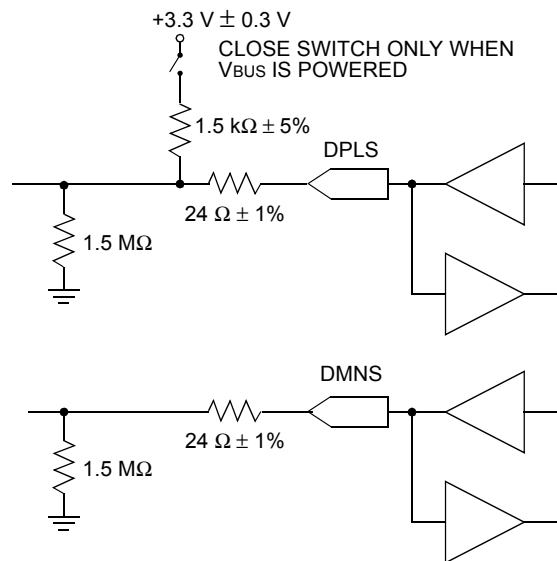

Figure 9. USB Transceiver Connection Example for Bus-Powered Application

5-8119

When using the USS-820D in a self-powered device, there are some additional considerations. The device must refrain from supplying power through the pull-up resistor if plugged into an unpowered bus. It must also ensure that the DPLS and DMNS lines are in an appropriate state when the device is powered but not plugged in. Figure 10 shows an example connection to meet these requirements.



5-8120

Figure 10. USB Transceiver Connection Example for Self-Powered Application

Electrical Characteristics (continued)

Connection Requirements (continued)

Oscillator Connection Requirements

The USS-820D requires an internal 48 MHz clock that it creates from an internal 12 MHz clock via a 4X PLL. Two methods of clock generation may be used to create this internal 12 MHz clock. Figure 11 shows the internal oscillator mode which requires only an external 12 MHz crystal and bias capacitors. The values of the capacitors should be chosen as indicated by the crystal manufacturer in order to cause the crystal to operate in a parallel resonant condition. A typical value is 15 pF, but the required value may differ, depending on the specific crystal and board characteristics of the application.

Alternatively, Figure 12 shows the configuration required to input a 12 MHz clock from an external oscillator. In either configuration, the external clock source must have the characteristics defined in Table 46.

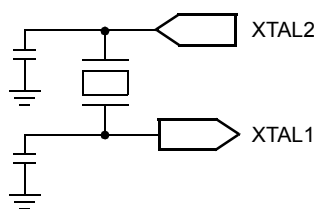

5-5405.a

Figure 11. Internal Oscillator Mode

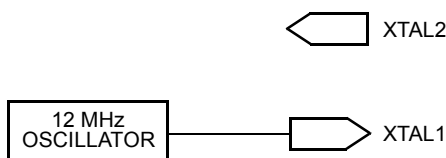

5-5406.a

Figure 12. External Oscillator Source

Table 46. Clock Characteristics

Parameter	Symbol	Min	Typ	Max	Unit
External Clock Source Frequency	f	11.976	12.000	12.024	MHz
Clock Period	t _{CYC}	83.1	83.3	83.5	ns
Clock Duty Cycle*	t _{CL} , t _{CH}	40	50	60	%
Oscillator Stable Time	t _{Osc}	—	—	7	ms

* Duty cycle applies to any frequency in an specified range.

Outline Diagrams

44-Pin MQFP (USS-820D)

Dimensions are in millimeters.

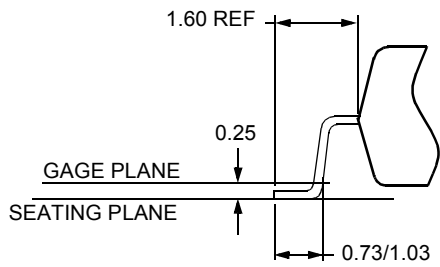
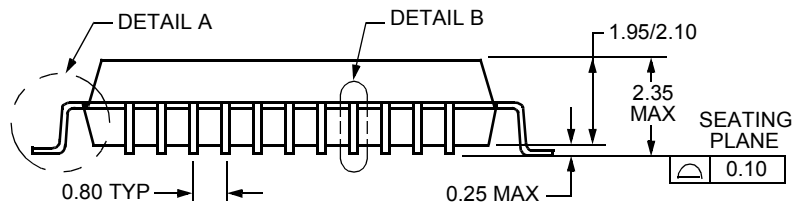
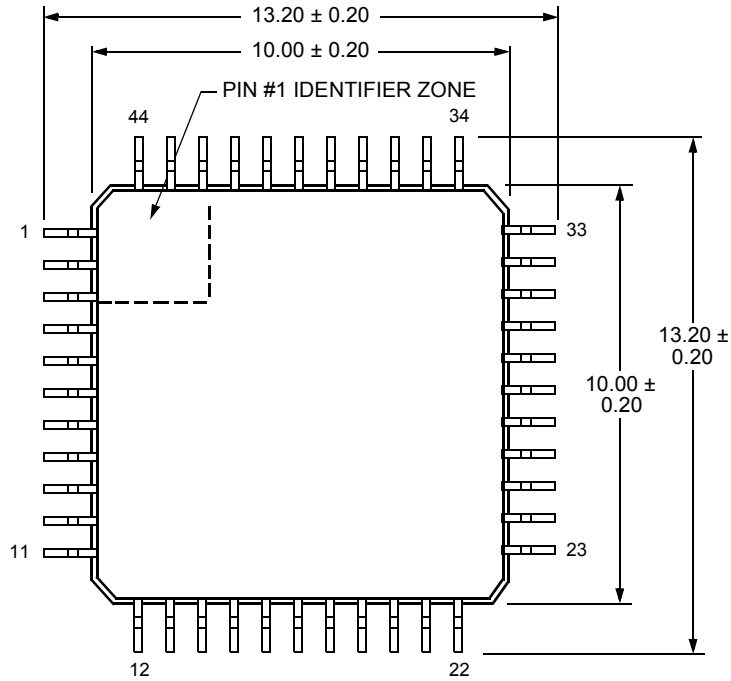

DETAIL A

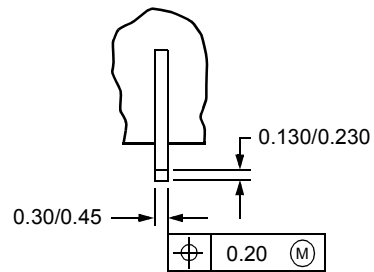

DETAIL B

5-2111

Outline Diagrams (continued)

48-Pin TQFP (USS-820TD)

Dimensions are in millimeters.

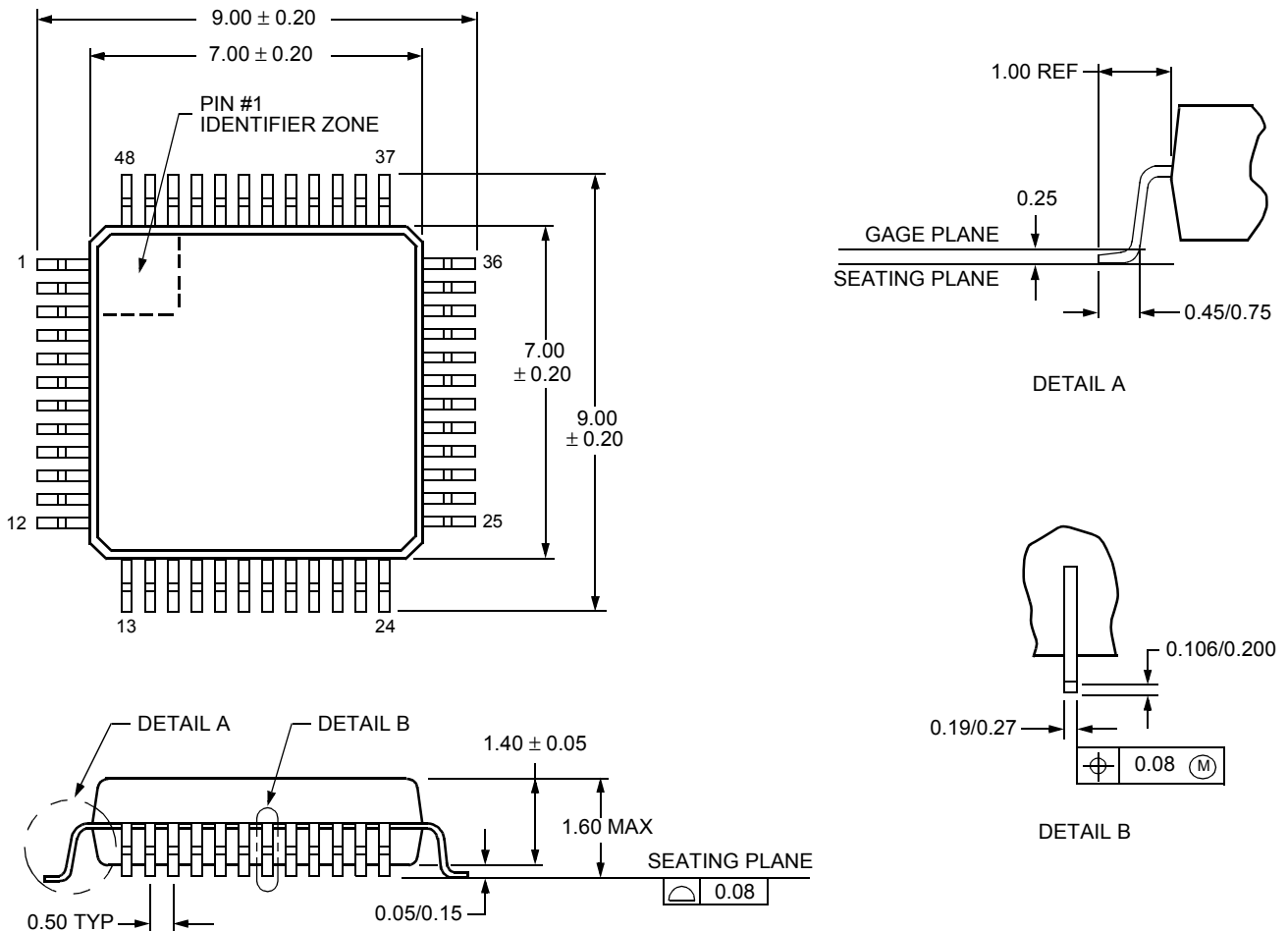

5-2363

Ordering Information

Device Code	Package	Comcode
USS820D-DB	44-Pin MQFP	108557463
USS820TD-DB*	48-Pin TQFP	108557539

* Due to size constraints for the 48-pin TQFP package, the device package will be marked USS82TC-DB instead of USS820TD-DB.

Appendix A. Special Function Register Bit Names

Table 47. Alphabetical Listing of Special Function Register Bit Names

Bit Name	Register	Table	Page	Bit Name	Register	Table	Page
A[6:0]	FADDR	21	26	RXFIF[1:0]	RXFLG	29	33
ADVRM	TXCON	24	27	RXFLUSH	RXFLG	29	33
ADVWM	RXCON	28	32	RXFULL	RXFLG	29	33
ARM	RXCON	28	32	RXIE	EPCON	18	21
ASOF	SOFH	15	19	RXISO	RXCON	28	32
ATM	TXCON	24	27	RXOVF	RXFLG	29	34
BC[7:0]	RXCNTL	27	31	RXSEQ	RXSTAT	20	24
BC[7:0]	TXCNTL	23	26	RXSETUP	RXSTAT	20	24
BC[9:8]	RXCNTH	27	31	RXSOVW	RXSTAT	20	24
BC[9:8]	TXCNTH	23	26	RXSPM	EPCON	18	21
BDFEAT	MCSR	36	39	RXSTL	EPCON	18	21
CTLEP	EPCON	18	21	RXURF	RXFLG	29	34
DPEN	MCSR	36	39	RXVOID	RXSTAT	20	25
EDOVW	RXSTAT	20	24	SCRATCH	SCRATCH	35	38
EPINX[2:0]	EPINDEX	17	20	SOFACK	SOFH	15	19
FEAT	MCSR	36	39	SOFIE	SOFH	15	19
FFSZ[1:0]	RXCON	28	31	SOFODIS	SOFH	15	19
FFSZ[1:0]	TXCON	24	27	SRESET	SCR	30	36
FRXD[3:0]	SBI	13	17	STOVW	RXSTAT	20	24
FRXD[7:4]	SBI1	14	17	SUSPDIS	SSR	31	37
FRXIE[3:0]	SBIE	11	16	SUSPEND	SSR	31	37
FRXIE[7:4]	SBIE1	12	16	SUSPLOE	MCSR	36	39
FTLOCK	SOFH	15	19	SUSPPO	SSR	31	37
FTXD[3:0]	SBI	13	17	SUSPS	MCSR	36	39
FTXD[7:4]	SBI1	14	18	T_IRQ	SCR	30	36
FTXIE[3:0]	SBIE	11	16	TS[10:8]	SOFH	15	19
FTXIE[7:4]	SBIE1	12	16	TS[7:0]	SOFL	16	20
IE_RESET	SCR	30	36	TXACK	TXSTAT	19	22
IE_RESUME	SCRATCH	35	38	TXAV[3:0]	DSAV	37	40
IE_SUSP	SCR	30	36	TXAV[7:4]	DSAV1	38	40
INIT	MCSR	36	39	TXCLR	TXCON	24	27
IRQLVL	SCR	30	36	TXDAT[7:0]	TXDAT	22	26
IRQPOL	SCR	30	36	TXDSAM	TXSTAT	19	22
PEND	PEND	34	38	TXEMP	TXFLG	25	28
PKGID	MCSR	36	39	TXEPEN	EPCON	18	21
RESET	SSR	31	37	TXERR	TXSTAT	19	22
RESUME	SSR	31	37	TXFIF[1:0]	TXFLG	25	28
REVRP	TXCON	24	27	TXFLUSH	TXSTAT	19	22
REVWP	RXCON	28	32	TXFULL	TXFLG	25	30
RWUPE	SCR	30	36	TXISO	TXCON	24	27
RWUPR	MCSR	36	39	TXNAKE	TXSTAT	19	22
RXACK	RXSTAT	20	25	TXOE	EPCON	18	21
RXAV[3:0]	DSAV	37	40	TXOVF	TXFLG	25	28
RXAV[7:4]	DSAV1	38	40	TXSEQ	TXSTAT	19	22
RXCLR	RXCON	28	31	TXSOVW	TXSTAT	19	22
RXDAT[7:0]	RXDAT	26	30	TXSTL	EPCON	18	21
RXEMP	RXFLG	29	34	TXURF	TXFLG	25	28
RXEPEN	EPCON	18	21	TXVOID	TXSTAT	19	22
RXERR	RXSTAT	20	25	UNLOCKED	LOCK	33	38
RXFFRC	RXCON	28	31				

Appendix B. USS-820D Register Map

Table 48. USS-820D Register Map

Register	USS-820D Register Map								Addr	
TXDAT	TXDAT[7:0]								00*	
TXCNTL	BC[7:0]								01*	
TXCNTH	—						BC[9:8]		02*	
TXCON	TXCLR	TXFFSZ[1:0]		—	TXISO	ATM	ADVVM	REVRP	03*	
TXFLG	TXFIF[1:0]		—		TXEMP	TXFULL	TXURF	TXOVF	04*	
RXDAT	RXDAT[7:0]								05*	
RXCNTL	BC[7:0]								06*	
RXCNTH	—						BC[9:8]		07*	
RXCON	RXCLR	RXFFSZ [1:0]		RXFFRC	RXISO	ARM	ADVVM	REVWP	08*	
RXFLG	RXFIF[1:0]		—	RXFLUSH	RXEMP	RXFULL	RXURF	RXOVF	09*	
EPINDEX	—					EPINX[2:0]			0A	
EPCON	RXSTL	TXSTL	CTLEP	RXSPM	RXIE	RXEPEN	TXOE	TXEPEN	0B*	
TXSTAT	TXSEQ	TXDSAM	TXNAKE	TXFLUSH	TXSOVW	TXVOID	TXERR	TXACK	0C*	
RXSTAT	RXSEQ	RXSETUP	STOVW	EDOVW	RXSOVW	RXVOID	RXERR	RXACK	0D*	
SOFL	TS[7:0]								0E	
SOFH	SOFACK	ASOF	SOFIE	FTLOCK	SOFODIS	TS[10:8]			0F	
FADDR	—								A[6:0]	10
SCR	IRQPOL	RWUPE	IE_SUSP	IE_RESET	SRESET	IRQLVL	T_IRQ	—	11	
SSR	—			SUSPPO	SUSPDIS	RESUME	SUSPEND	RESET	12	
SBI	FRX03	FTX03	FRX02	FTX02	FRX01	FTX01	FRX00	FTX00	14	
SBI1	FRX07	FTX07	FRX06	FTX06	FRX05	FTX05	FRX04	FTX04	15	
SBIE	FRXIE3	FTXIE3	FRXIE2	FTXIE2	FRXIE1	FTXIE1	FRXIE0	FTXIE0	16	
SBIE1	FRXIE7	FTXIE7	FRXIE6	FTXIE6	FRXIE5	FTXIE5	FRXIE4	FTXIE4	17	
REV	REV[7:0]								18	
LOCK	—							UNLOCKED	19	
PEND	—							PEND	1A	
SCRATCH	IE_RESUME	SCRATCH[6:0]							1B	
MCSR	RWUPR	INIT	SUSPS	PKGID	FEAT	BDFEAT	SUSPLOE	DPEN	1C	
DSAV	RXAV3	TXAV3	RXAV2	TXAV2	RXAV1	TXAV1	RXAV0	TXAV0	1D	
DSAV1	RXAV7	TXAV7	RXAV6	TXAV6	RXAV5	TXAV5	RXAV4	TXAV4	1E	

* Indexed by EPINDEX.

Appendix C. Changes from USS-820/ USS-825 Revision B to C

Note: For Revision C, the USS-825B has been renamed USS-820TC.

1. Hardware revision register (REV) changed from 1.0 to 1.1.
2. From the USB system and firmware points of view, the USS-820C will appear functionally equivalent to the USS-820B if a 1 is never written by firmware to MCSR[3:2] or TXSTAT[6:5] (all previously marked as reserved). The single exception is the REV register as described above.
3. New register bits (FEAT, BDFEAT) are added to enable new features. BDFEAT enables those features which could impact existing boards. This could only be an issue if NC pins were used as connection points for other board signals. FEAT enables all other features as indicated. FEAT is MCSR[3]; BDFEAT is MCSR[2].
4. New FIFO status bits (RXAV/TXAV), one per FIFO, added to indicate receive data set(s) available (RXFIF > 00) or empty transmit data set(s) available (TXFIF < 11). If TXDSAM = 1, transmit FIFO status bits are set if the device sends a NAK in response to an IN packet when TXFIF = 00. The 16 register bits are formatted into two new registers (DSAV = address 1D, DSAV1 = address 1E) in the same format as SBI/SBI1. These new read-only bits can allow firmware to operate more efficiently, because their use requires less polling overhead. Register bits always read 0 unless FEAT = 1 or TXDSAM = 1.
5. A logical OR of new FIFO status bits (RXAV/TXAV) is brought out to a package pin (DSA). Package pin is always 3-stated if BDFEAT = 0. Uses pin 15 in 44-pin package, pin 16 in 48-pin package.
6. New nonisochronous transmit mode. If enabled (by new register bit TXNAKE = TXSTAT[5]), when the USS-820C responds to an IN token with a NAK because of no data sets being present (TXFIF = 00), an interrupt is generated, setting the appropriate SBI/SBI1 bit. New register bit TXDSAM (TXSTAT[6]) allows this condition to set the new DSAV register bit and assert the new DSA output pin (assuming they are enabled). This mode changes the meaning of TXVOID to indicate that such a NAK was sent, and it is the responsibility of firmware to clear TXVOID. While TXVOID = 1, the corresponding SBI/SBI1 register bit will remain set as well.
7. Transmit isochronous behavior changed to discard old data packets at the end of the intended frame if not read out by a host IN (only enabled if FEAT = 1). Data sets are not visible to the host until the first SOF following the data set write. At the start of a series of transfers, TXFIF will equal 00, which could allow firmware to write two data sets during that same frame. In that case, the older set is flushed by hardware at the first SOF.
8. Receive isochronous behavior changed to flush old data packets at the end of the intended frame if not read out by firmware (only enabled if FEAT = 1). This flush decrements RXFIF and sets the RXFLUSH register bit (RXFLG[4]), which firmware must check before setting RXFFRC. While RXFLUSH is set, the effect of firmware RXDAT reads (FIFO pointer/flag changes) is blocked, to avoid possible corruption of a new data set. If firmware detects that RXFLUSH = 1, it must discard the data set just read, since it is possibly truncated. Firmware must still set RXFFRC in this situation, which resets RXFLUSH to 0.
9. ASOF behavior changed to not automatically reset when SOFODIS = 0 if FEAT = 1.
10. For nonisochronous endpoints, FFSZ = 2 indicates 8 bytes, FFSZ = 3 indicates 32 bytes (both are interpreted as 64 bytes in the USS-820 revision B). This will potentially allow more efficient usage of the shared FIFO space. Only enabled if FEAT = 1.
11. USB-reset-detected condition clears the FADDR register (if FEAT = 1). This avoids the potential case where firmware is too slow in resetting FADDR after USB RESET such that the host re-allocates the address to some other device and sends traffic to that device, which is misinterpreted by the USS-820C as intended for it. No other register bits are cleared by USB reset.
12. USB-reset-detected condition brought out to package pin (USBR), allowing the external controller to clear out a locked up device. Output is always 3-stated if BDFEAT = 0. Uses pin 18 of 44-pin package, pin 19 of 48-pin package.
13. Firmware provided means to resume and reset device if suspended. When suspended, if SUSPP0 = 0, SUSPLOE = 0, FEAT = 1, a firmware write of 1 to SCR bit 3 (SRESET) causes a remote wake-up type of event (without resume signaling). After the wake-up, when clocks are turned on, the SRESET bit will be set and will take effect (i.e., the USS-820C will be reset).

Appendix C. Changes from USS-820/ USS-825 Revision B to C (continued)

14. Remote-wake-up-remember condition is visible as a register bit (RWUPR). Register bit always reads a 0 unless FEAT = 1. RWUPR is MCSR[7].
15. Additional/updated electrical characteristics related to the new 0.25 μm process (power, hysteresis leakage current) are included.
16. The VDD5V pin is no longer required—may be treated as no connect.

Appendix D. Changes from USS-820/ USS-820T Revision C to D

1. All (4) USS-820C/USS-820TC advisory items are corrected.
2. Value of REV register is changed from 11h to 13h.

For additional information, contact your Agere Systems Account Manager or the following:

INTERNET: <http://www.agere.com>

E-MAIL: docmaster@micro.lucent.com

N. AMERICA: Agere Systems Inc., 555 Union Boulevard, Room 30L-15P-BA, Allentown, PA 18109-3286

1-800-372-2447, FAX 610-712-4106 (In CANADA: **1-800-553-2448**, FAX 610-712-4106)

ASIA PACIFIC: Agere Systems Singapore Pte. Ltd., 77 Science Park Drive, #03-18 Cintech III, Singapore 118256

Tel. (65) 778 8833, FAX (65) 777 7495

CHINA: Agere Systems (Shanghai) Co., Ltd., 33/F Jin Mao Tower, 88 Century Boulevard Pudong, Shanghai 200121 PRC

Tel. (86) 21 50471212, FAX (86) 21 50472266

JAPAN: Agere Systems Japan Ltd., 7-18, Higashi-Gotanda 2-chome, Shinagawa-ku, Tokyo 141, Japan

Tel. (81) 3 5421 1600, FAX (81) 3 5421 1700

EUROPE: Data Requests: DATALINE: **Tel. (44) 7000 582 368**, FAX (44) 1189 328 148

Technical Inquiries: GERMANY: **(49) 89 95086 0** (Munich), UNITED KINGDOM: **(44) 1344 865 900** (Ascot),

FRANCE: **(33) 1 40 83 68 00** (Paris), SWEDEN: **(46) 8 594 607 00** (Stockholm), FINLAND: **(358) 9 3507670** (Helsinki),

ITALY: **(39) 02 6608131** (Milan), SPAIN: **(34) 1 807 1441** (Madrid)

Agere Systems Inc. reserves the right to make changes to the product(s) or information contained herein without notice. No liability is assumed as a result of their use or application.