

THIS COPY IS PROVIDED ON A RESTRICTED BASIS AND IS NOT TO BE USED IN ANY WAY DETRIMENTAL TO THE INTERESTS OF PANDUIT CORP.

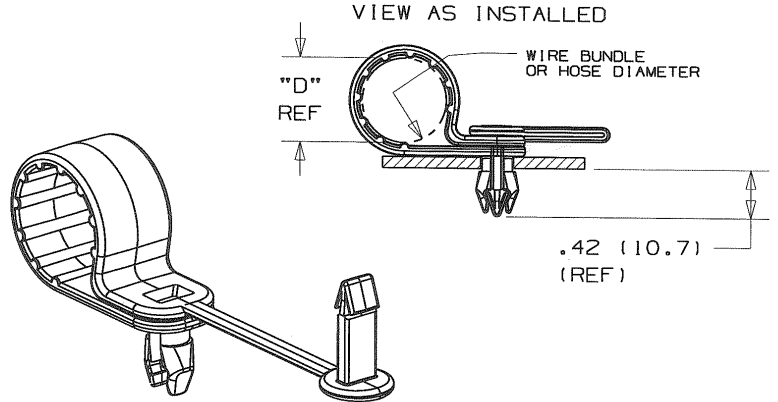
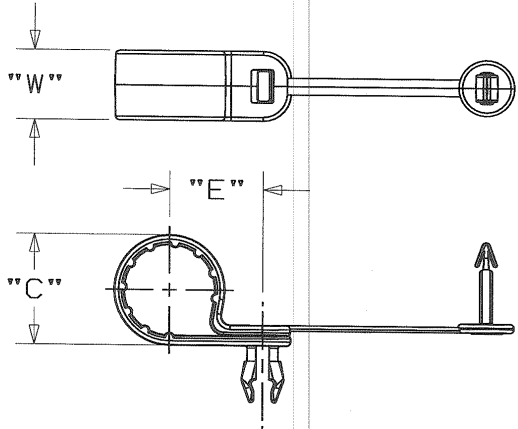

SCALE: FULL

NOTES:

- SEE CURRENT PRICE SHEET FOR PART NUMBER SUFFIX DESIGNATION FOR PACKAGE SIZE AND COLOR.
- MOUNTING HOLE DIAMETER: 1/4" CLEARANCE - .281" [ 7mm ]  
PANEL THICKNESS: .125" [ 3.2mm ] NOMINAL
- SPECIFIED DIAMETER IS CABLE OR HOSE THAT IS BEING INSTALLED.

PANDUIT PART NO. (SEE NOTE 1)	DIMENSIONS				WEIGHT lbs / [ g ] 100/ pcs
	"C"	"D" DIAMETER REF SEE NOTE 3	"E" (REF.)	"W"	
PC038-H25D-_-	.58 [ 14.7 ]	.38 [ 9.5 ]	.64 [ 16.3 ]	.62 [ 15.7 ]	.74 / [ 1340 ]
PC050-H25D-_-	.70 [ 17.8 ]	.50 [ 12.7 ]	.71 [ 17.9 ]		.83 / [ 1380 ]
PC062-H25D-_-	.82 [ 20.8 ]	.62 [ 15.8 ]	.77 [ 19.5 ]		.92 / [ 1420 ]
PC075-H25D-_-	.95 [ 24.1 ]	.75 [ 19.1 ]	.83 [ 21.1 ]		1.02 / [ 1465 ]
PC087-H25D-_-	1.07 [ 27.2 ]	.87 [ 22.1 ]	.89 [ 22.7 ]		1.11 / [ 1505 ]
PC100-H25D-_-	1.20 [ 30.5 ]	1.00 [ 25.4 ]	.96 [ 24.3 ]		1.21 / [ 1550 ]
PC112-H25D-_-	1.33 [ 33.8 ]	1.12 [ 28.5 ]	1.02 [ 25.8 ]		1.29 / [ 1585 ]
PC125-H25D-_-	1.45 [ 36.8 ]	1.25 [ 31.8 ]	1.08 [ 27.4 ]		1.37 / [ 1620 ]

DIMENSIONS IN BRACKETS ARE METRIC [ mm ]  
CAD FILENAME/LAYERS G03597ID\_DC\_GB2320CA/OOB

**PANDUIT** CORP. TINLEY PARK, ILLINOIS

PAN-CLAMP  
(PC\_\_\_-H25D-\_-)

UNLESS OTHERWISE SPECIFIED,  
DIMENSIONAL TOLERANCES ARE:  
(.X) ±0.05 [ 1.3 ] (.XXX) ±0.010 [ 0.25 ]  
(.XX) ±0.02 [ 0.5 ] ANGLES ±5°

UNLESS OTHERWISE SPECIFIED,  
ALL DIMENSIONS ARE GIVEN  
IN INCHES, THIRD ANGLE PROJECTION.

REV	DATE	BY	CHK	DESCRIPTION	ECN	R	CUST	SUP
00B	02/24/09	GDH		CHANGED REVISION STYLE AND FILE NAME FORMAT. ADDED COLUMN "C".	GB2320CA	00B		
5	5/9/01	KLN		UPDATED PART WEIGHTS, E, AND W DIMENSIONS	GB2320CA	5		
4	3/22/01	KLN		UPDATED PRODUCT PART NUMBERS	GB2320CA	4		

DRAWN BY JAD  
DATE 4-26-00  
CHK'D KLN

MAT'L:  
WEATHER RESISTANT  
IMPACT MODIFIED  
NYLON 6/6

SCALE 3/4  
DRAWING NO. GB2320CA  
Dwg SIZE A