

SFH615A-1, SFH615A-2,  
SFH615A-3, SFH615A-4



**LOW INPUT CURRENT  
PHOTOTRANSISTOR  
OPTICALLY COUPLED ISOLATORS**

**APPROVALS**

- UL recognised, File No. E91231

**DESCRIPTION**

The SFH615A series of optically coupled isolators consist of infrared light emitting diodes and NPN silicon photo transistors in space efficient dual in line plastic packages.

**FEATURES**

- Options :-  
10mm lead spread - add G after part no.  
Surface mount - add SM after part no.  
Tape&reel - add SMT&R after part no.
- Low input current 1mA  $I_F$
- High Current Transfer Ratios  
(40-320% at 10mA, 13% min at 1mA)
- High Isolation Voltage (5.3kV<sub>RMS</sub>, 7.5kV<sub>PK</sub>)
- High BV<sub>CEO</sub> (70V min)
- All electrical parameters 100% tested
- Custom electrical selections available

**APPLICATIONS**

- Computer terminals
- Industrial systems controllers
- Measuring instruments
- Signal transmission between systems of different potentials and impedances

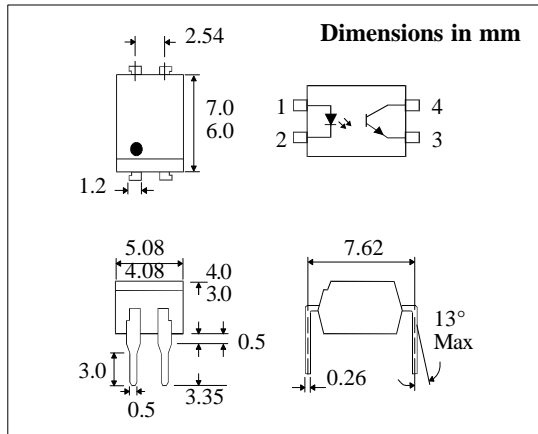

**ABSOLUTE MAXIMUM RATINGS  
(25°C unless otherwise specified)**

Storage Temperature \_\_\_\_\_ -55°C to + 125°C  
 Operating Temperature \_\_\_\_\_ -55°C to + 100°C  
 Lead Soldering Temperature  
 (1/16 inch (1.6mm) from case for 10 secs) 260°C

**INPUT DIODE**

Forward Current \_\_\_\_\_ 50mA  
 Reverse Voltage \_\_\_\_\_ 6V  
 Power Dissipation \_\_\_\_\_ 70mW

**OUTPUT TRANSISTOR**

Collector-emitter Voltage BV<sub>CEO</sub> \_\_\_\_\_ 70V  
 Emitter-collector Voltage BV<sub>ECO</sub> \_\_\_\_\_ 6V  
 Power Dissipation \_\_\_\_\_ 150mW

**POWER DISSIPATION**

Total Power Dissipation \_\_\_\_\_ 200mW  
 (derate linearly 2.67mW/°C above 25°C)

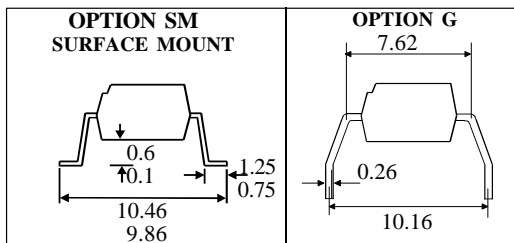

**ISOCOMCOMPONENTSLTD**  
 Unit 25B, Park View Road West,  
 Park View Industrial Estate, Brenda Road  
 Hartlepool, Cleveland, TS25 1YD  
 Tel: (01429) 863609 Fax: (01429) 863581

**ELECTRICAL CHARACTERISTICS (  $T_A = 25^\circ\text{C}$  Unless otherwise noted )**

PARAMETER		MIN	TYP	MAX	UNITS	TEST CONDITION
Input	Forward Voltage ( $V_F$ )	6		1.65	V	$I_F = 50\text{mA}$ $I_R = 10\mu\text{A}$ $V_R = 6\text{V}$
	Reverse Voltage ( $V_R$ )				V	
	Reverse Current ( $I_R$ )			10	$\mu\text{A}$	
Output	Collector-emitter Breakdown ( $BV_{CEO}$ ) ( Note 2 )	70			V	$I_C = 1\text{mA}$
	Emitter-collector Breakdown ( $BV_{ECO}$ )	6			V	$I_E = 100\mu\text{A}$
	Collector-emitter Dark Current ( $I_{CEO}$ ) SFH615A-1,2 SFH615A-3,4			50 100	nA nA	$V_{CE} = 10\text{V}$
Coupled	Current Transfer Ratio (CTR) (Note 2) SFH615A-1 SFH615A-2 SFH615A-3 SFH615A-4	40		80	%	$10\text{mA } I_F, 5\text{V } V_{CE}$
		63		125	%	
		100		200	%	
		160		320	%	
	SFH615A-1 SFH615A-2 SFH615A-3 SFH615A-4	13			%	$1\text{mA } I_F, 5\text{V } V_{CE}$
		22			%	
		34			%	
		56			%	
	Collector-emitter Saturation Voltage $V_{CESAT}$			0.4	V	$10\text{mA } I_F, 2.5\text{mA } I_C$
	Input to Output Isolation Voltage $V_{ISO}$	5300 7500			$V_{RMS}$ $V_{PK}$	See note 1 See note 1
Input-output Isolation Resistance $R_{ISO}$	$5 \times 10^{10}$			$\Omega$	$V_{IO} = 500\text{V}$ (note 1)	

Note 1 Measured with input leads shorted together and output leads shorted together.

Note 2 Special Selections are available on request. Please consult the factory.

**SWITCHING CHARACTERISTICS**

1. Linear Operation (without saturation) Fig 1.  
 $I_F = 10\text{mA}$ ,  $V_{CC} = 5\text{V}$ ,  $R_L = 75\Omega$

			UNITS
Turn-on Time $t_{on}$	3.0		$\mu\text{s}$
Rise Time $t_r$	2.0		$\mu\text{s}$
Turn-off Time $t_{off}$	2.3		$\mu\text{s}$
Fall Time $t_f$	2.0		$\mu\text{s}$
Cut-off Frequency $F_{CO}$	250		kHz

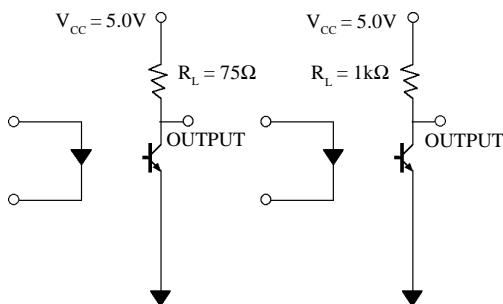
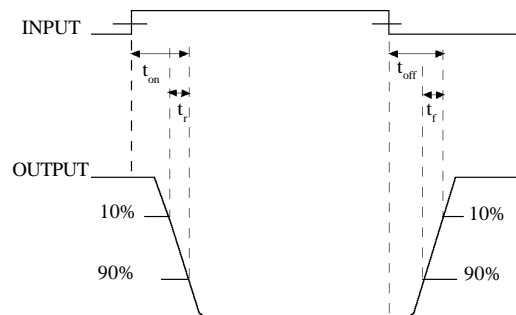

FIG 1

FIG 2

2. Switching Operation (with saturation) Fig 2  
 $V_{CC} = 5\text{V}$ ,  $R_L = 1\text{k}\Omega$

GROUP	-1 ( $I_F=20\text{mA}$ )	-2 and -3 ( $I_F=10\text{mA}$ )	-4 ( $I_F=5\text{mA}$ )	UNITS
Turn-on Time $t_{on}$	3.0	4.2	6.0	$\mu\text{s}$
Rise Time $t_r$	2.0	3.0	4.6	$\mu\text{s}$
Turn-off Time $t_{off}$	18	23	25	$\mu\text{s}$
Fall Time $t_f$	11	14	15	$\mu\text{s}$
$V_{CESAT}$	$\leq 0.4$			V



**Collector Power Dissipation vs. Ambient Temperature**

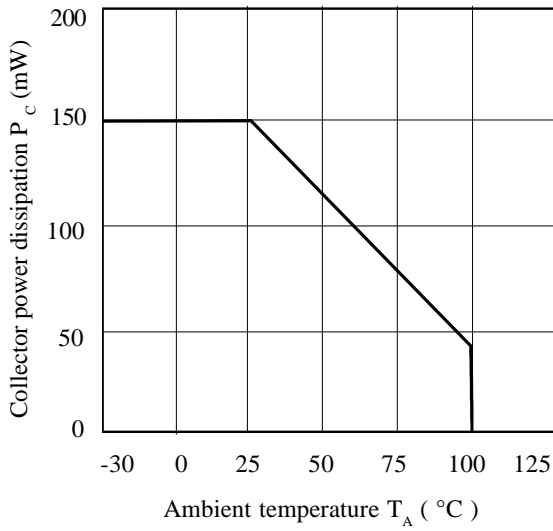

**Collector Current vs. Collector-emitter Voltage (normalised to SFH615A-3)**

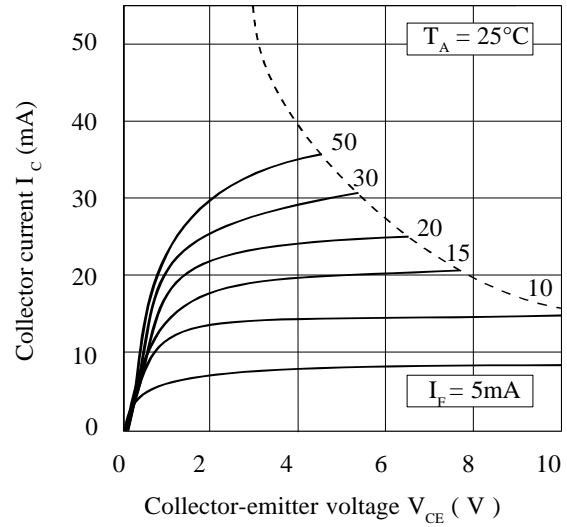

**Forward Current vs. Ambient Temperature**

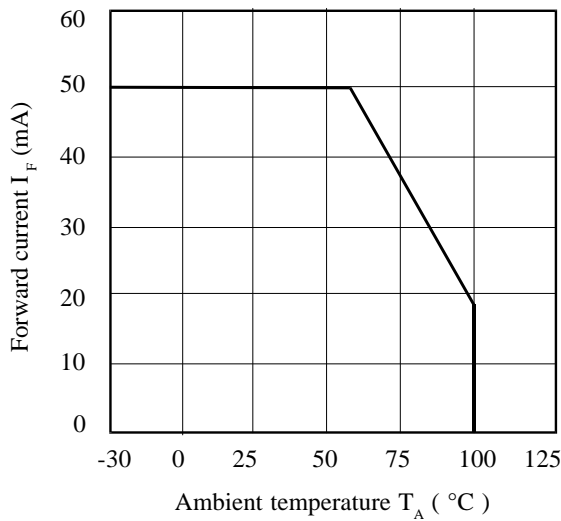

**Current Transfer Ratio vs. Forward Current**

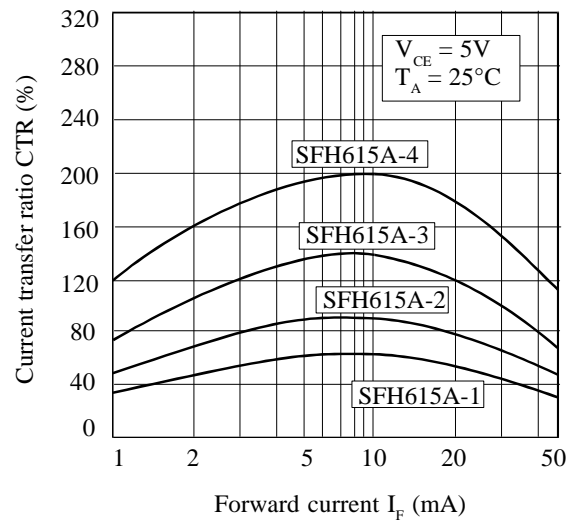

**Relative Current Transfer Ratio vs. Ambient Temperature**

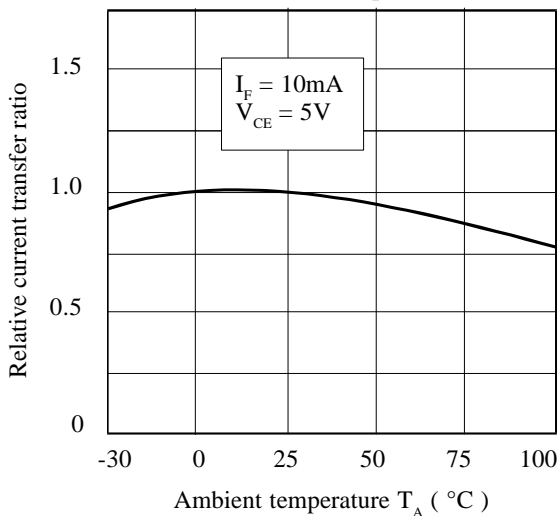

**Collector-emitter Saturation Voltage vs. Ambient Temperature**

